

A 30" WINGSPAN FLYING SCALE FREE FLIGHT MODEL
GLOSTER GAMECOCK
 Designed by
P. E. NORMAN
 Copyright of
The Aeromodeller Plans Service
 THE AERODROME, LEIGHTON BUZZARD, BEDS

All wood balsa unless otherwise stated

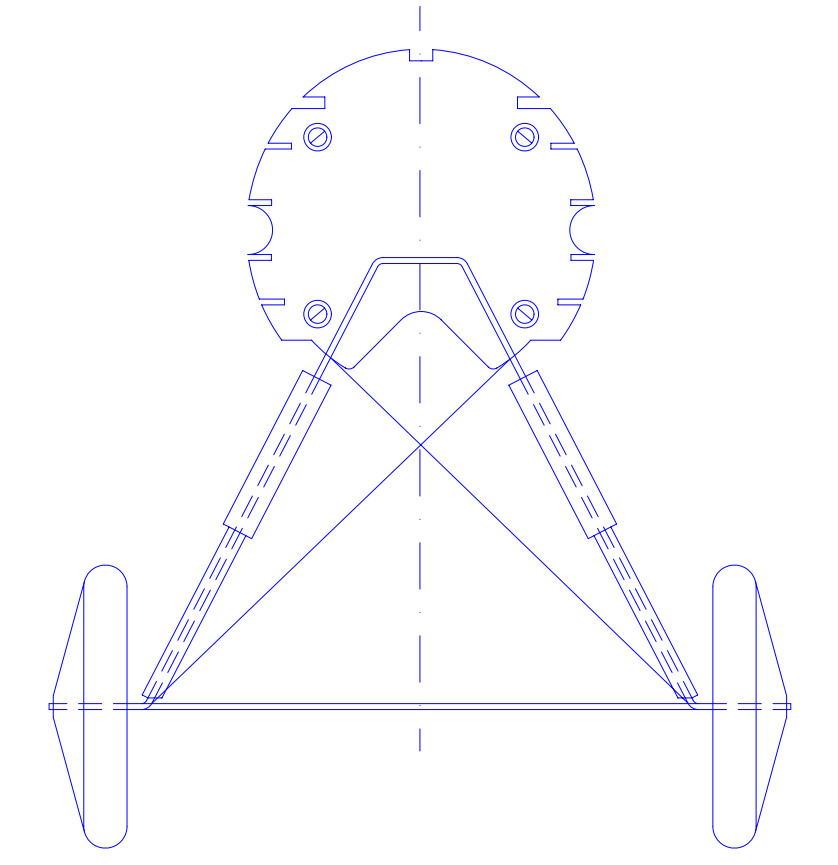

NOTE - TAIL INCIDENCE IS ADJUSTABLE BY SCREWING IN OR OUT OF TUBE IN REAR OF FUSELAGE

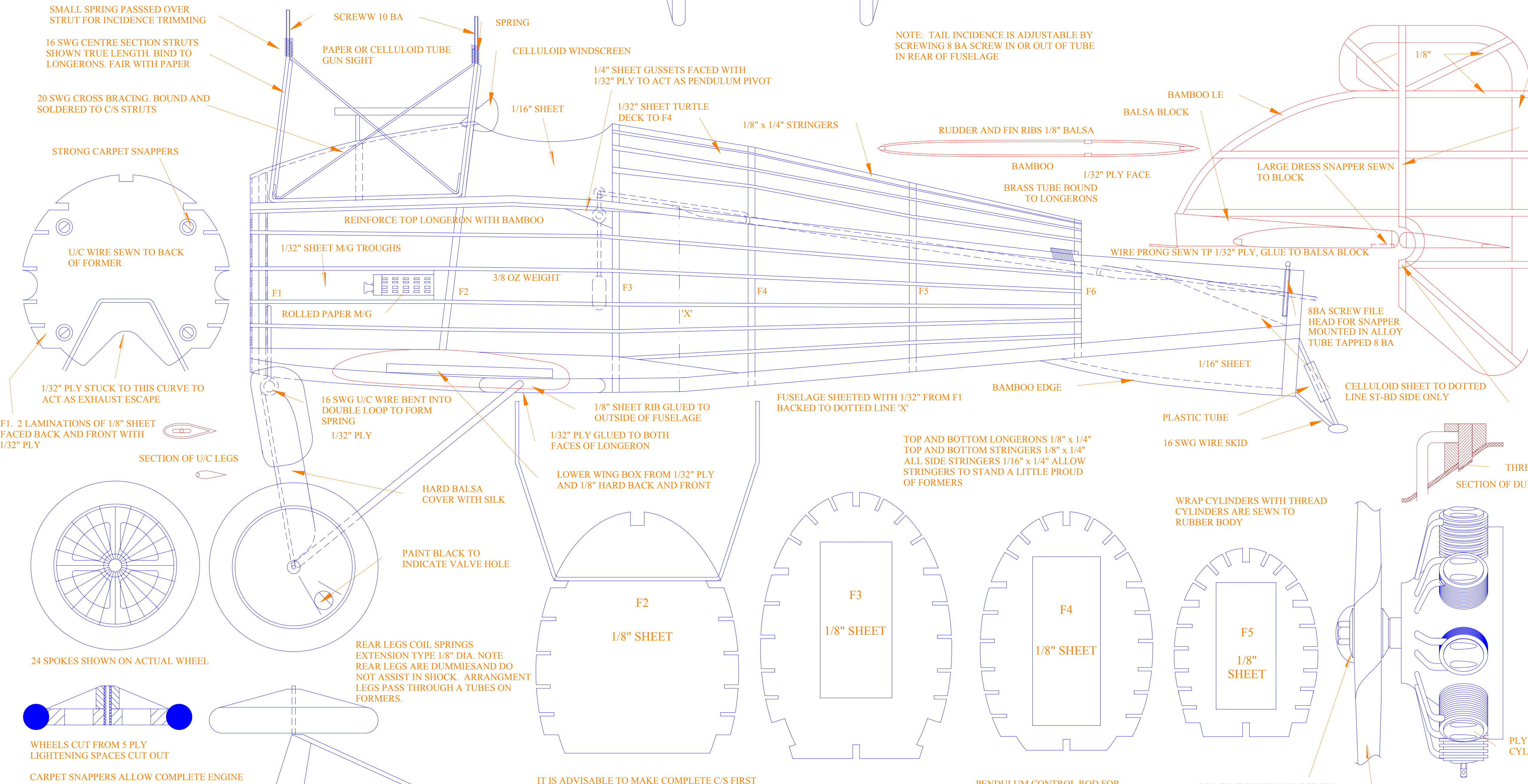

RUDDER OUTLINE 4 LAMINATIONS OF CANE

RUDDER MAINSPAR THIN BAMBOO EACH SIDE OF RIBS SPACE FILLED WITH Balsa

1/16" PLY SHAPE CUT TO CLEAR ELEVATOR

NOTE: A RETAINING PIN IS INSERTED IN FUSELAGE TO RESTRAIN DOWN MOVEMENT OF ELEVATORS. THIS IS ADVISABLE UNTIL MACHINE IS KNOWN, WHEN BUNTS AND EVEN INVERTED FLIGHT MAY BE PERFORMED

SECTION OF DUMMY ENGINE. DOPE ENGINE CYLS. MATT BLACK

PLASTIC TUBING OVER TRUE ENGINE CYLINDERS HELD BY SPRING LOADED ALUMINIUM WASHERS

ENGINE MOUNT TO TAKE ELFH 1.8 CC OR 'K' 1.9 CC INVERTED ADD EXTENSION TO CARD INTAKE AND NEEDLE

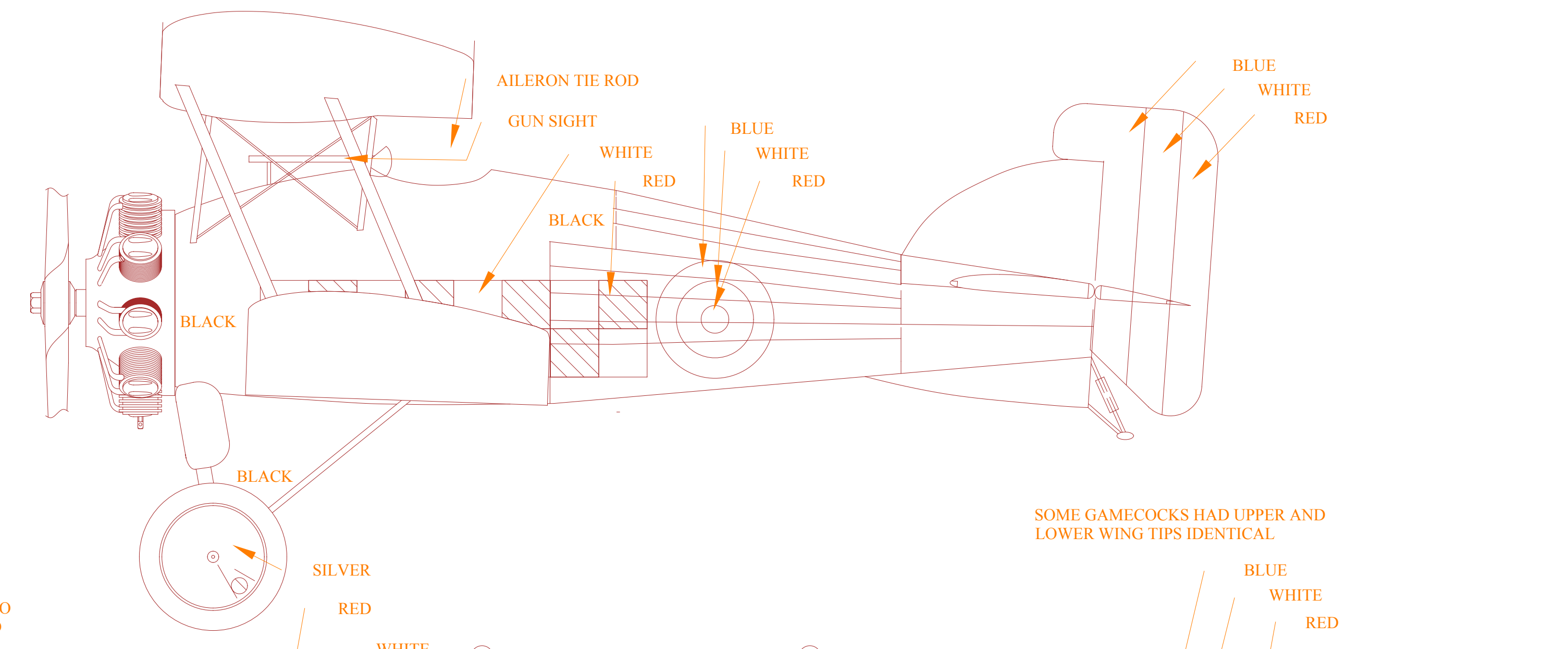

SOME GAMECOCKS HAD UPPER AND LOWER WING TIPS IDENTICAL.

