

Black Magic

Redrawn from Fred Hemsalls
1946 design for
Electric power

By

Vintage 1 April 2005

Sheet 1, Fuselage, fin, and tailplane

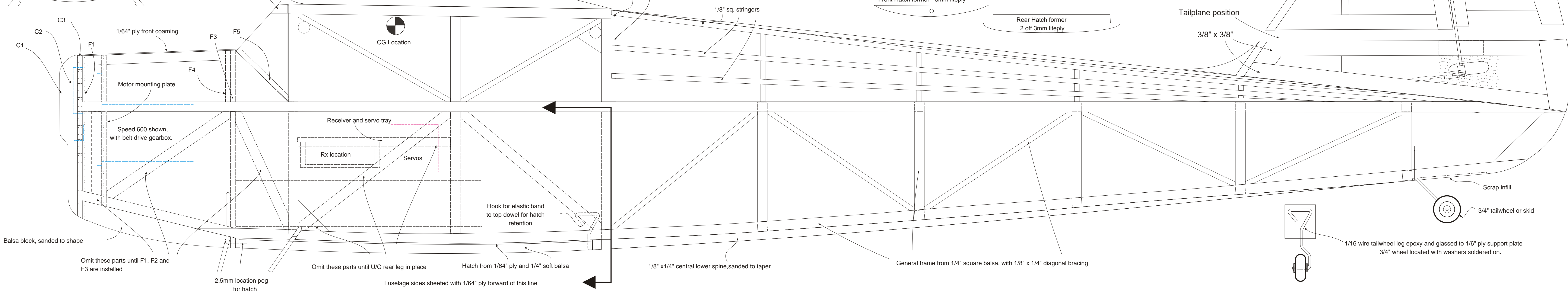
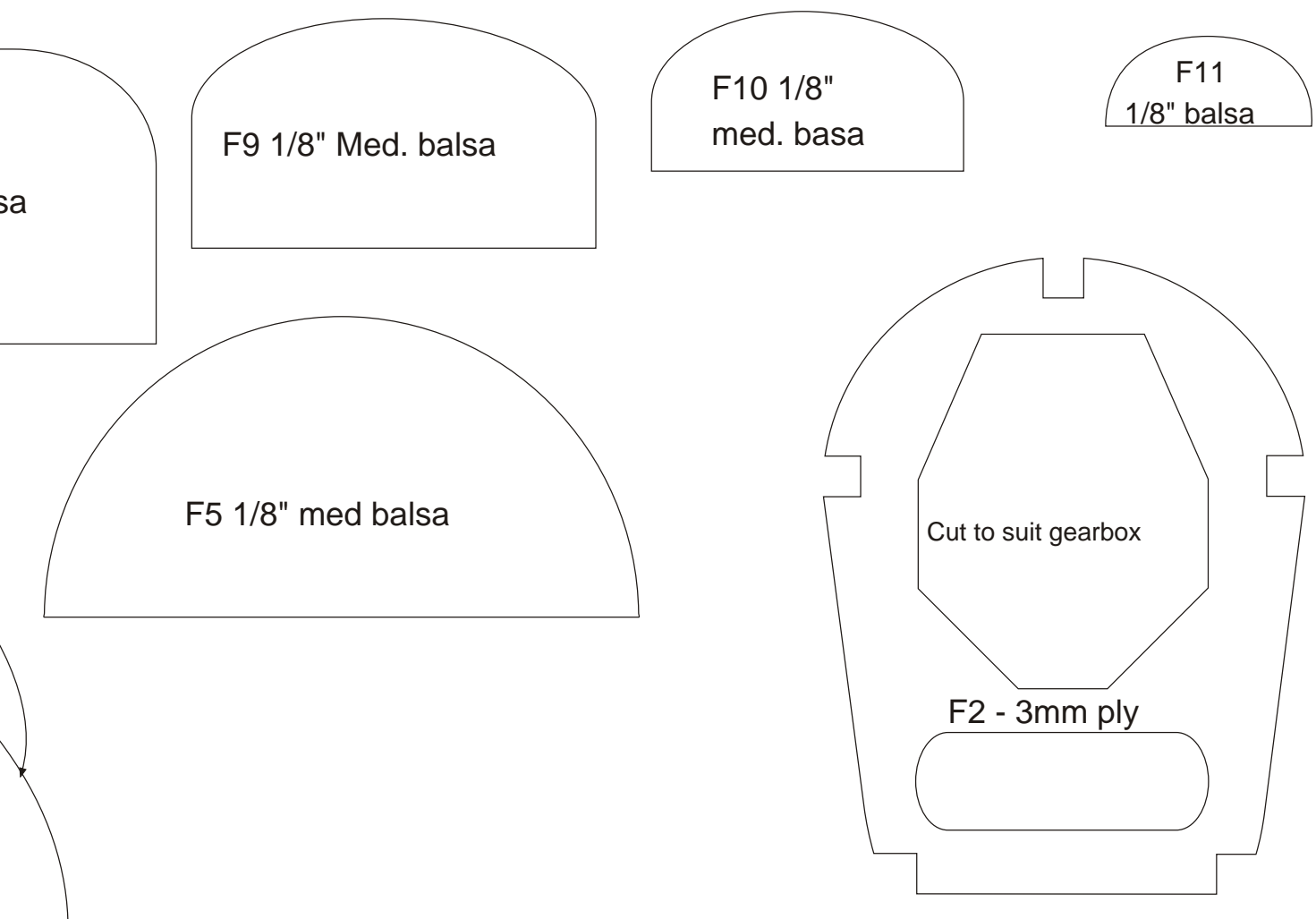
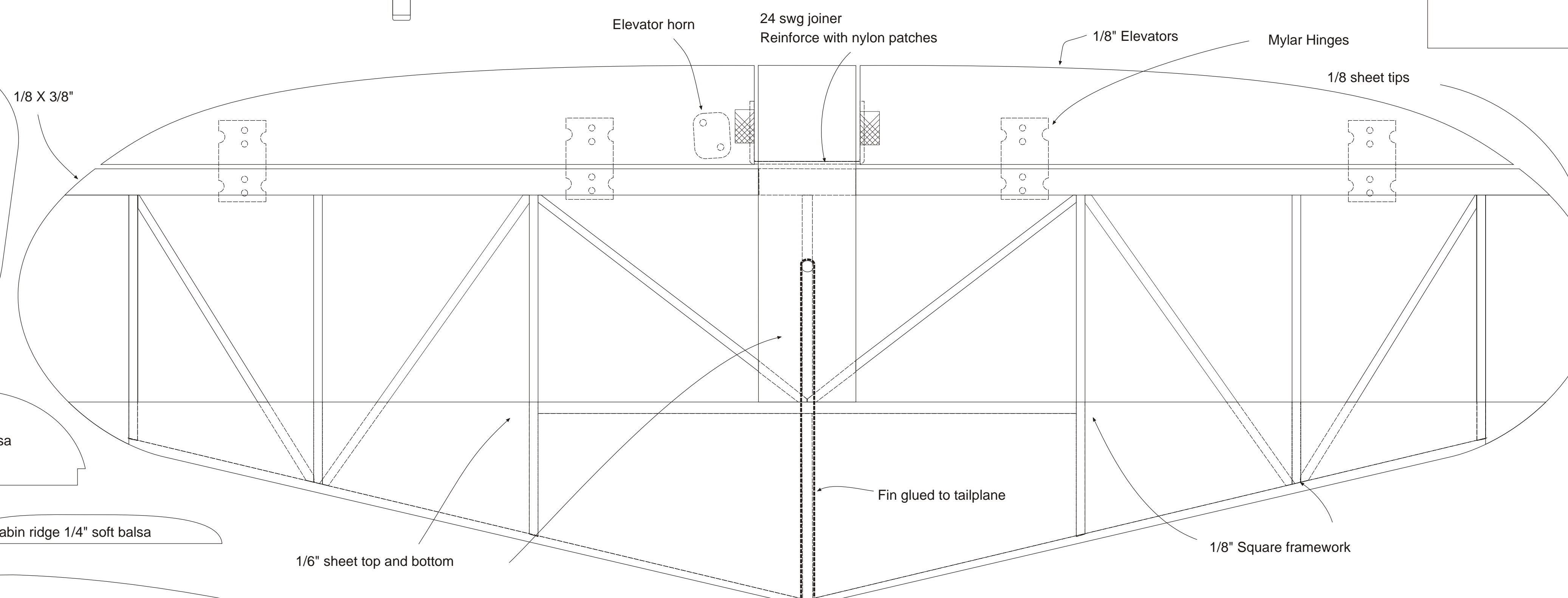
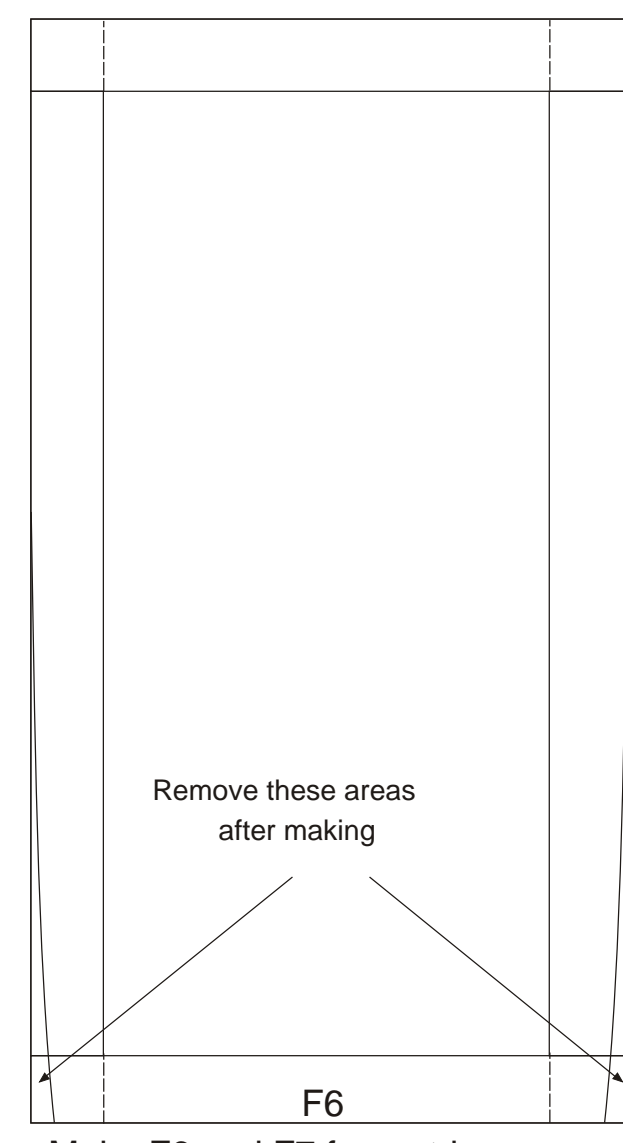
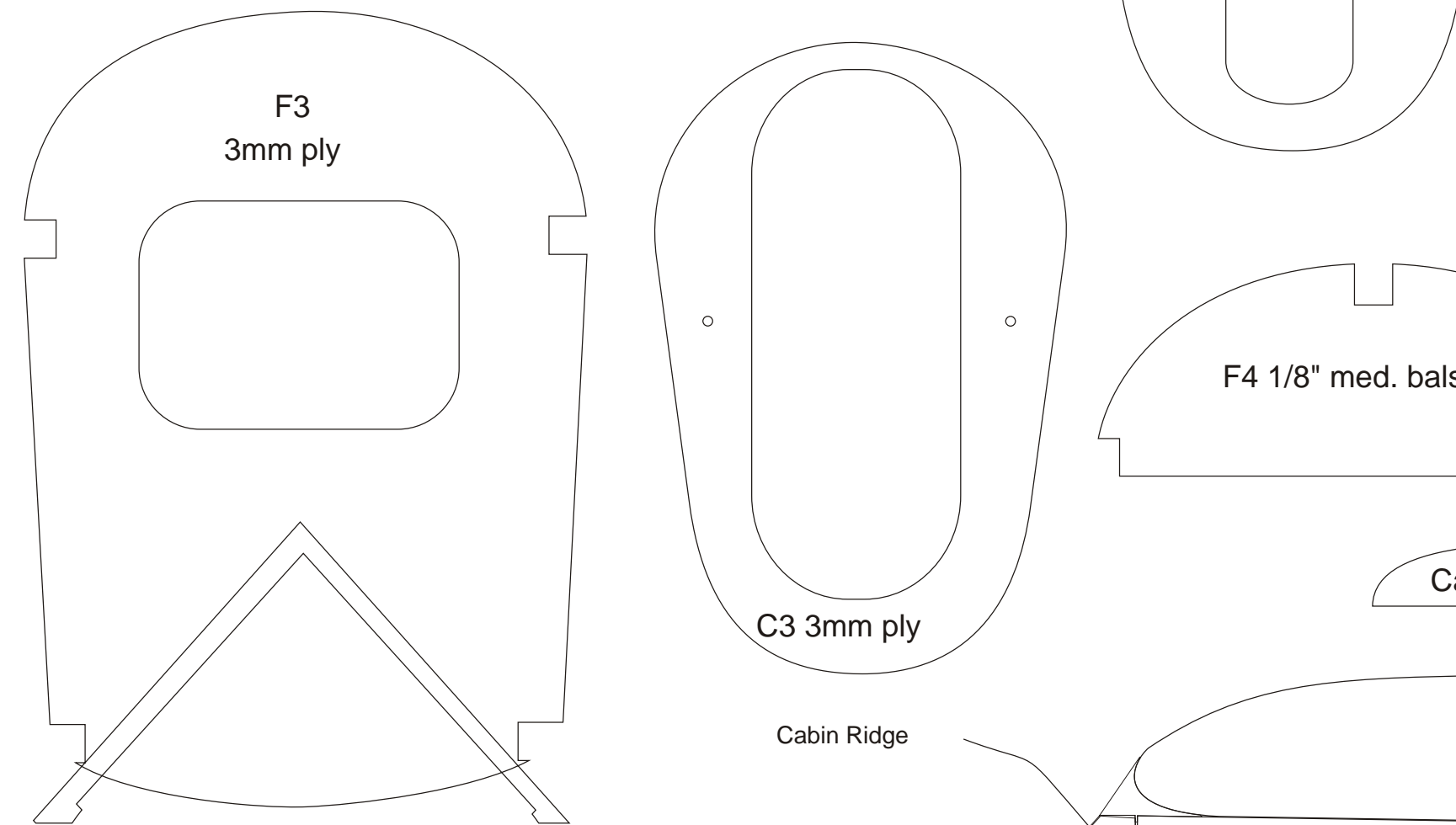
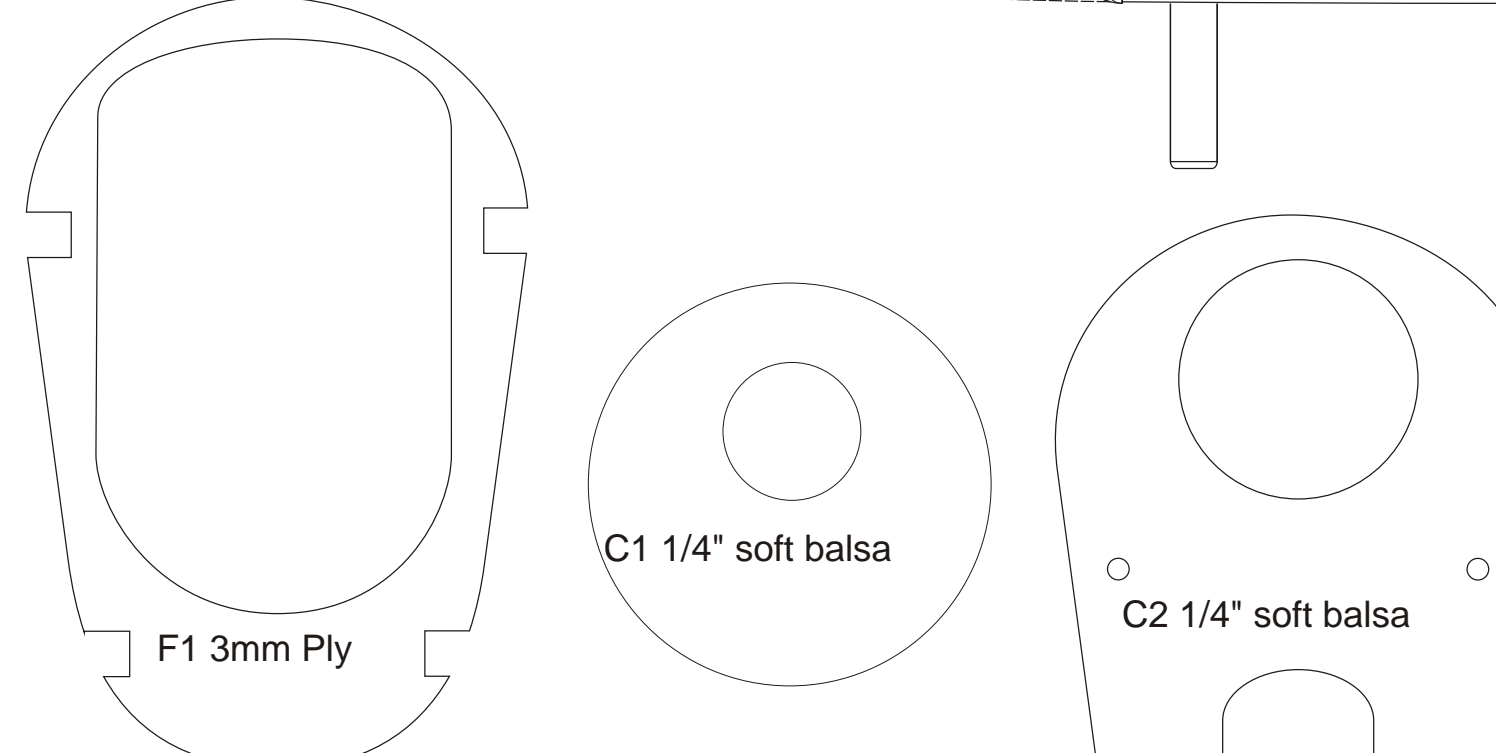
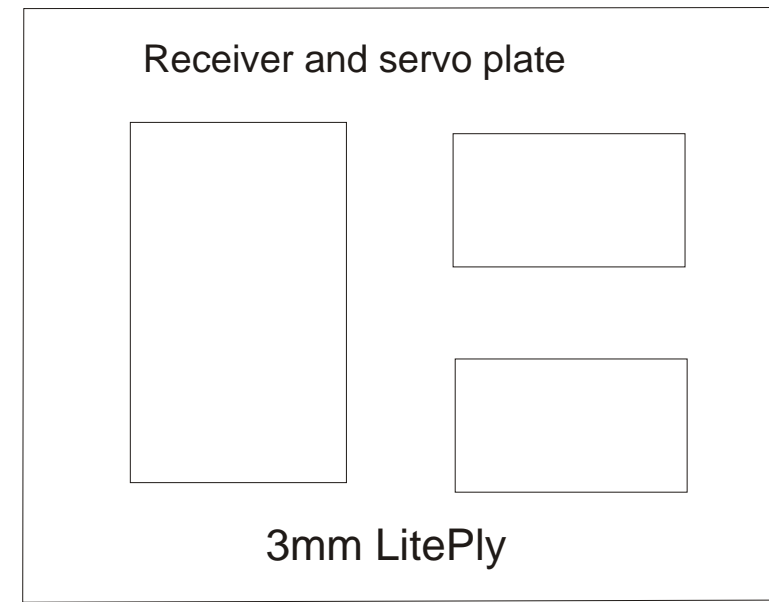
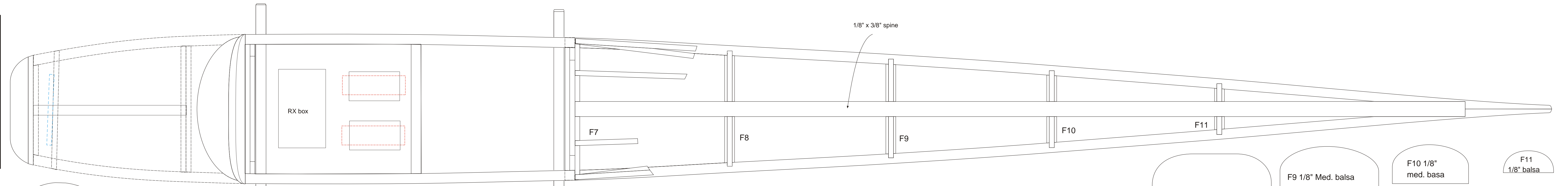

Black Magic
 Redrawn from Fred Hemsalls
 1946 design for
 Electric power
 By
 Vintage 1 April 2005
 Sheet 2, wings and undercarriage

R1 Template
 To set Dihedral
 Angle

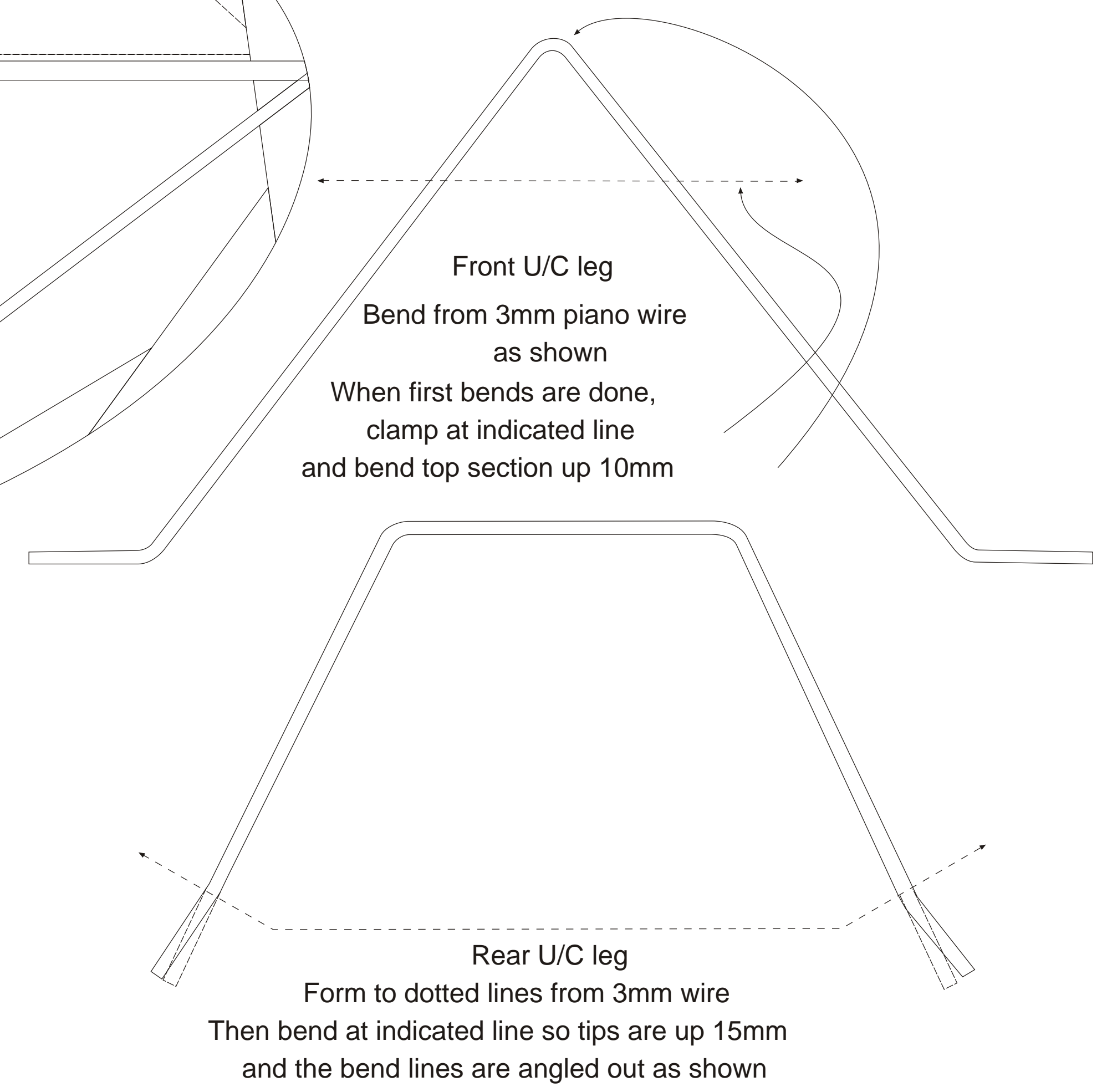
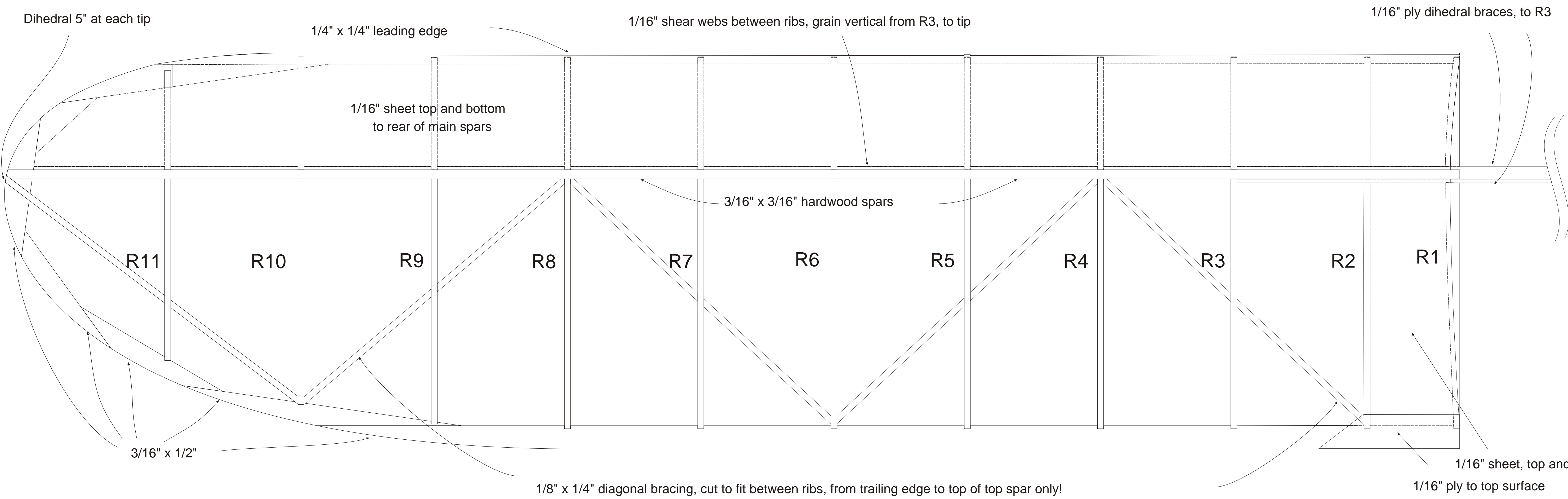
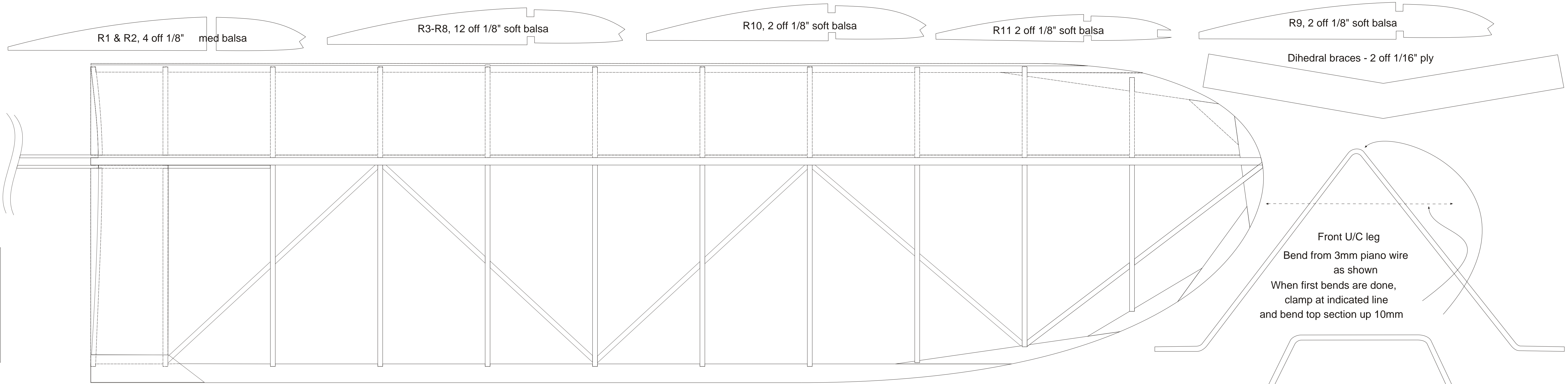

Front U/C legs are bound and glued, to the front of F3 before assembly
 Epoxy and glass cloth makes a stronger join

The rear legs are inserted through the structure, located with ply gussets then bound with copper wire to front U/C legs, and firmly soldered

Wheels should be 70mm or 2 1/2", located with soldered washers

After assembly, the U/C may be infilled with 1/8" hard balsa using epoxy, if desired