

INCIDENCE: (RELATIVE TO THRUST LINE)
 TOP WING: 3° POSITIVE
 LOWER WING: 0°
 HORIZONTAL TAILPLANE: 0°

1/64" SHEET

BALANCE POINT
 1/16" SQUARE WING STRUTS

FRONT
 WASHERS

A 4" DIA. KAYSUN PLASTIC PROPELLER WAS USED ON THE ORIGINAL MODEL

SILK THREAD

1/16" DIA. BAMBOO SKID

BIND AXLE TO SKID WITH THREAD & GLUE

THIN CARD STOCK FAIRINGS

REFERENCES:
 BRITISH AIRCRAFT 1809-1914 (P. LEWIS)
 THE AERO SEPT. 1912
 THE AEROPLANE DEC. 19, 1912

1/32" DIA. STRUTS

BAMBOO SKID

1/64" SHEET

FUSELAGE SIDES, TOP & BOTTOM: 1/32" SHEET

REAR RUBBER PEG (1/16" DIA. DOWEL)

BALSA NOSE BLOCK
 A DRILLED RIVET IS USED AS A THRUST BEARING

DIHEDRAL: 5/16" EACH TIP (ALL FOUR WING PANELS)

1/16" SQ. CROSS PIECE (TOP ONLY)

1/16" SQUARE (TYPICAL ON FORMERS 2, 5, 6)
 FORMER 2

1/16" SQ. LEADING EDGE

RIB POSITIONS

1/32" SHEET

1/32" SHEET RIB (MAKE 12)

STRUT OPENINGS

STRUT OPENINGS

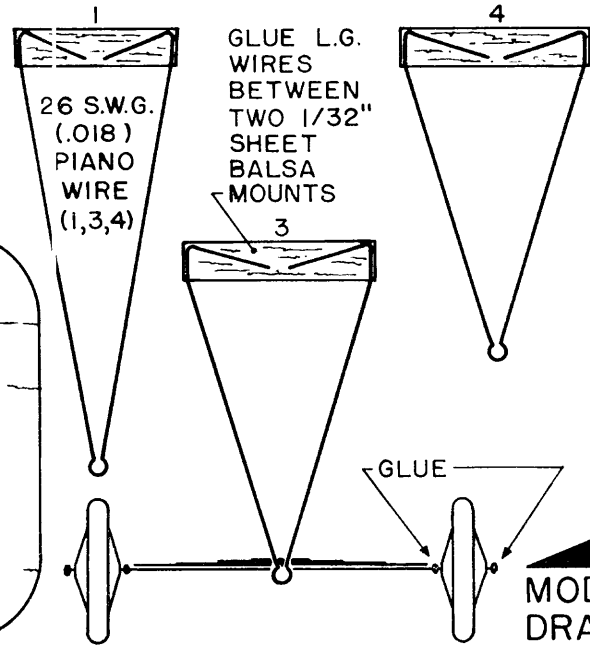

26 S.W.G. (.018) PIANO WIRE (1,3,4)
 GLUE L.G. WIRES BETWEEN TWO 1/32" SHEET BALSA MOUNTS

GLUE

TOP VIEW, 26 S.W.G. AXLE

TOP VIEW, SPRING (THIN CARD STOCK)

AVRO
 MODEL "G" ENCLOSED BIPLANE
 DRAWN BY W.C. HANNAN