

VERON Velox

44" Span.

AUXILIARY POWERED PUSHER

for .5 to .9 c.c. (.03 to .054 cu. ins.)

SUCH AS ALLBON "DART", "MERLIN" & SUPER MERLIN, E.D. "BABY", & "PEP" A.M. "O49", FROG O49, FROC 80, MILLS 75, D.C. "BANTAM", etc.

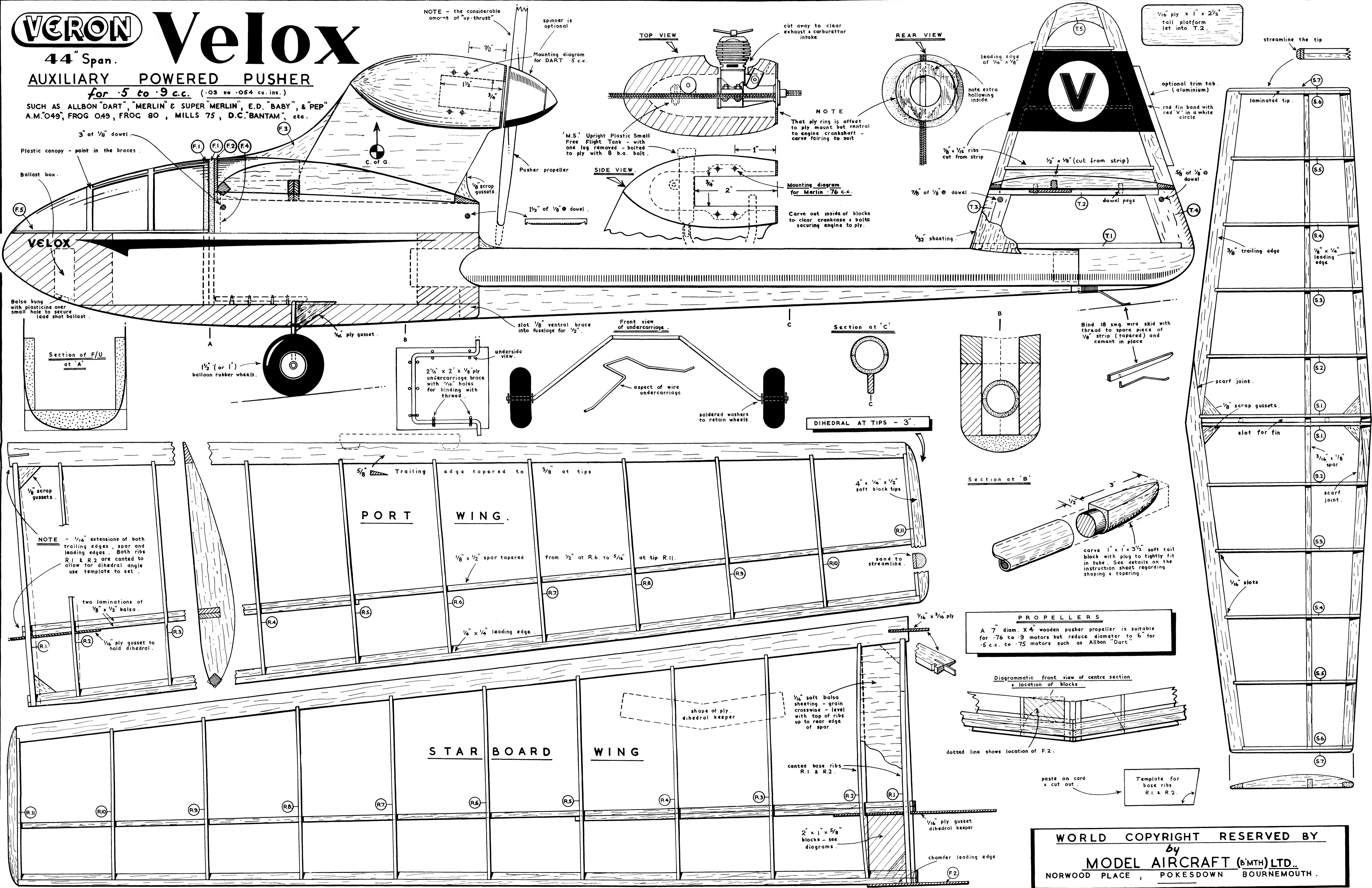

NOTE - the considerable amount of "up-thrust" spinner is optional
Mounting diagram for DART .5 c.c.

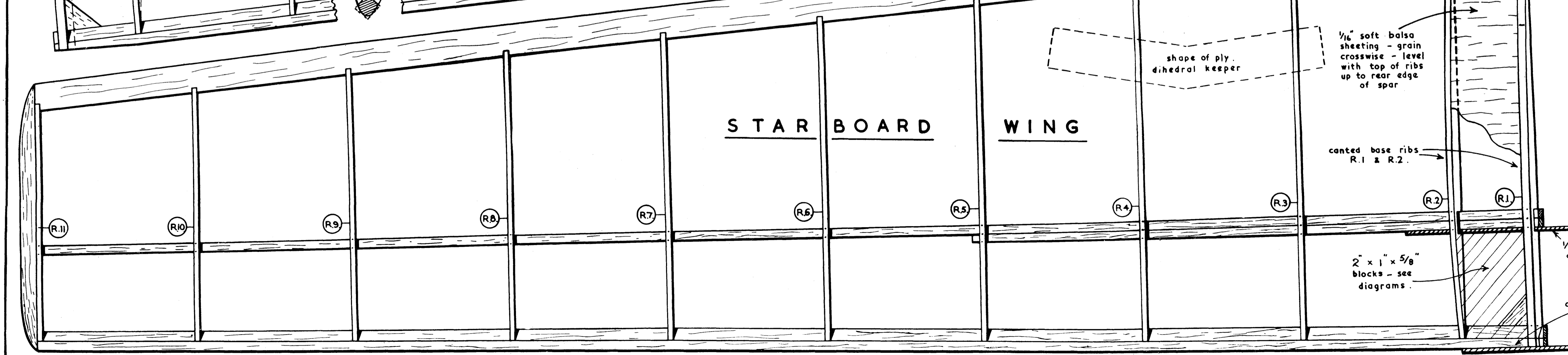
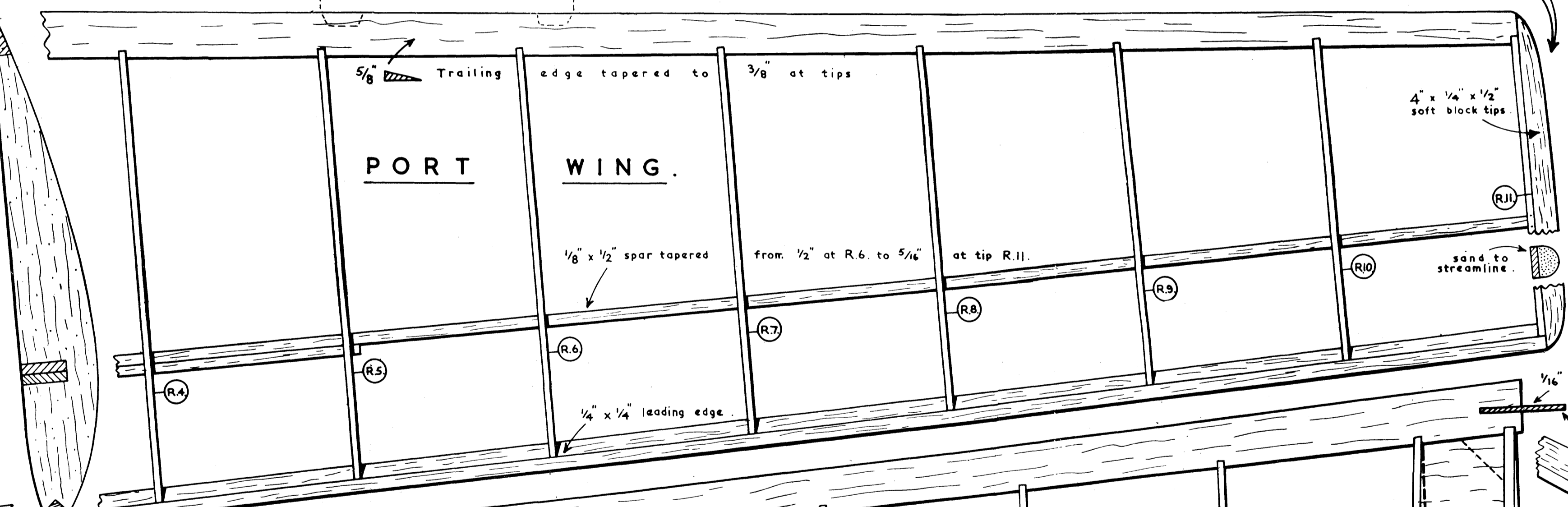
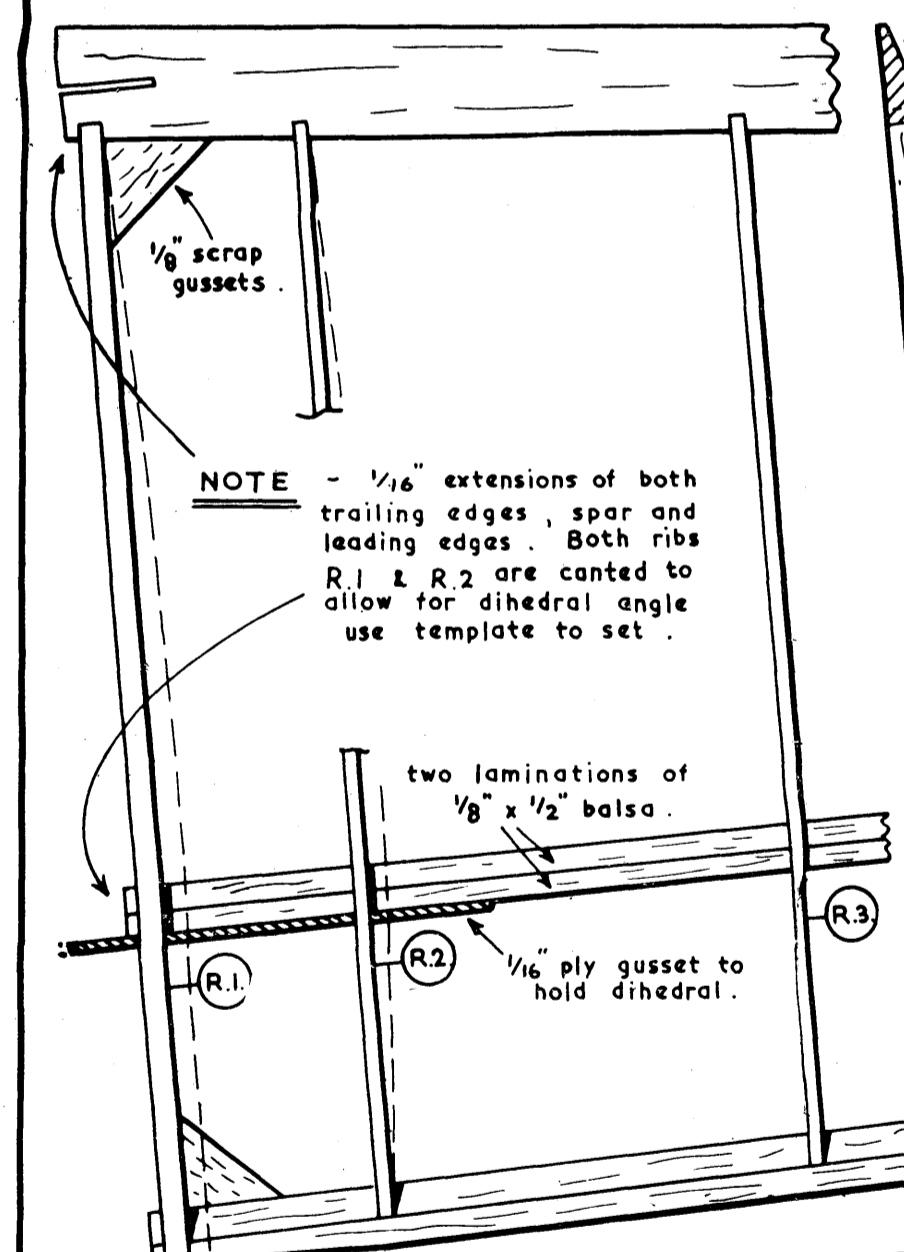
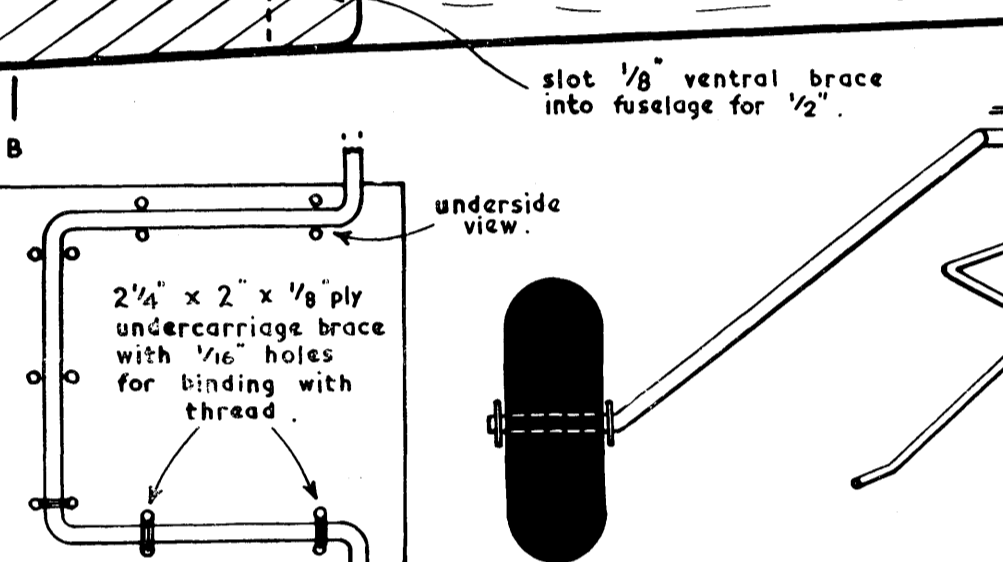
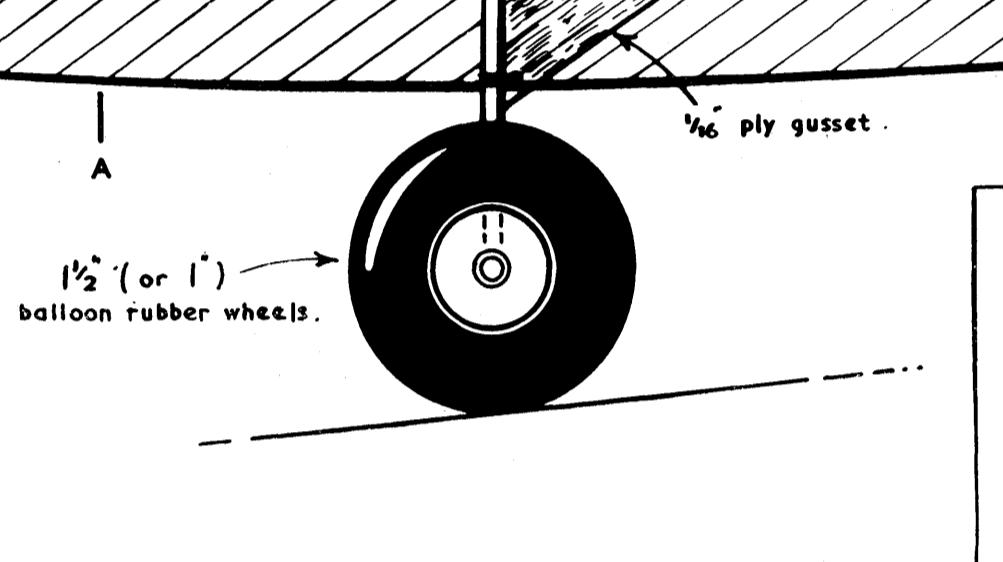
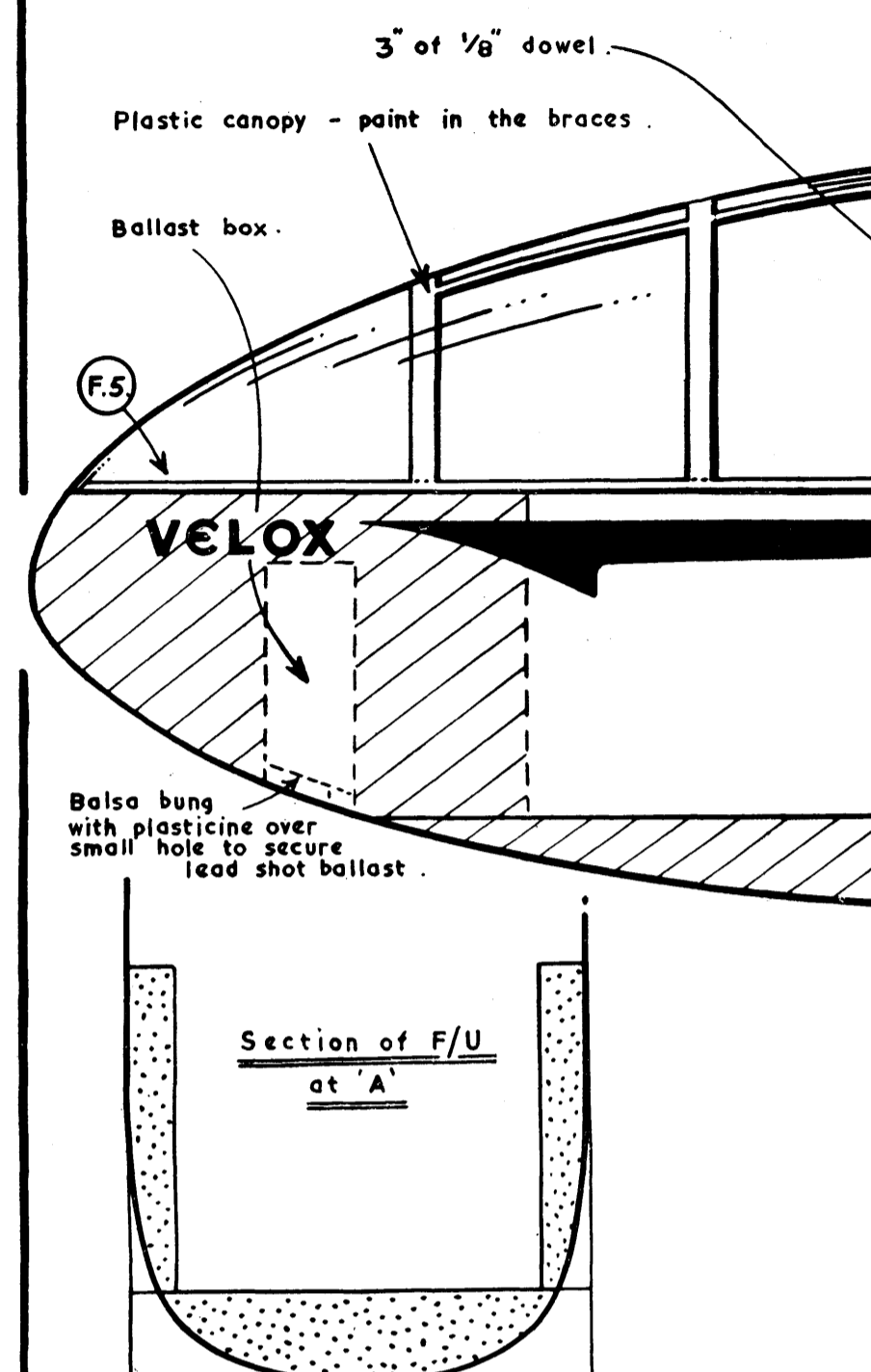
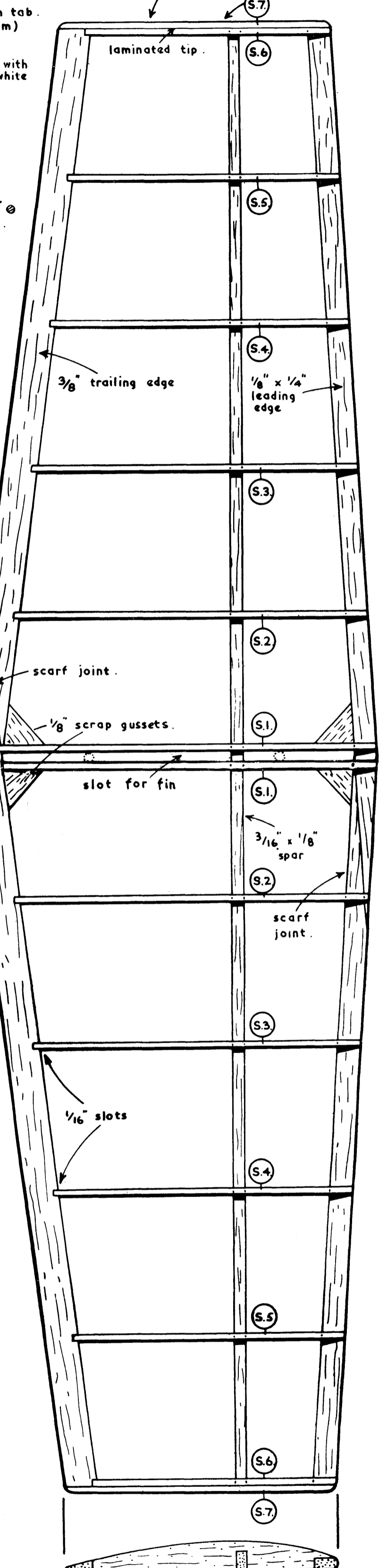
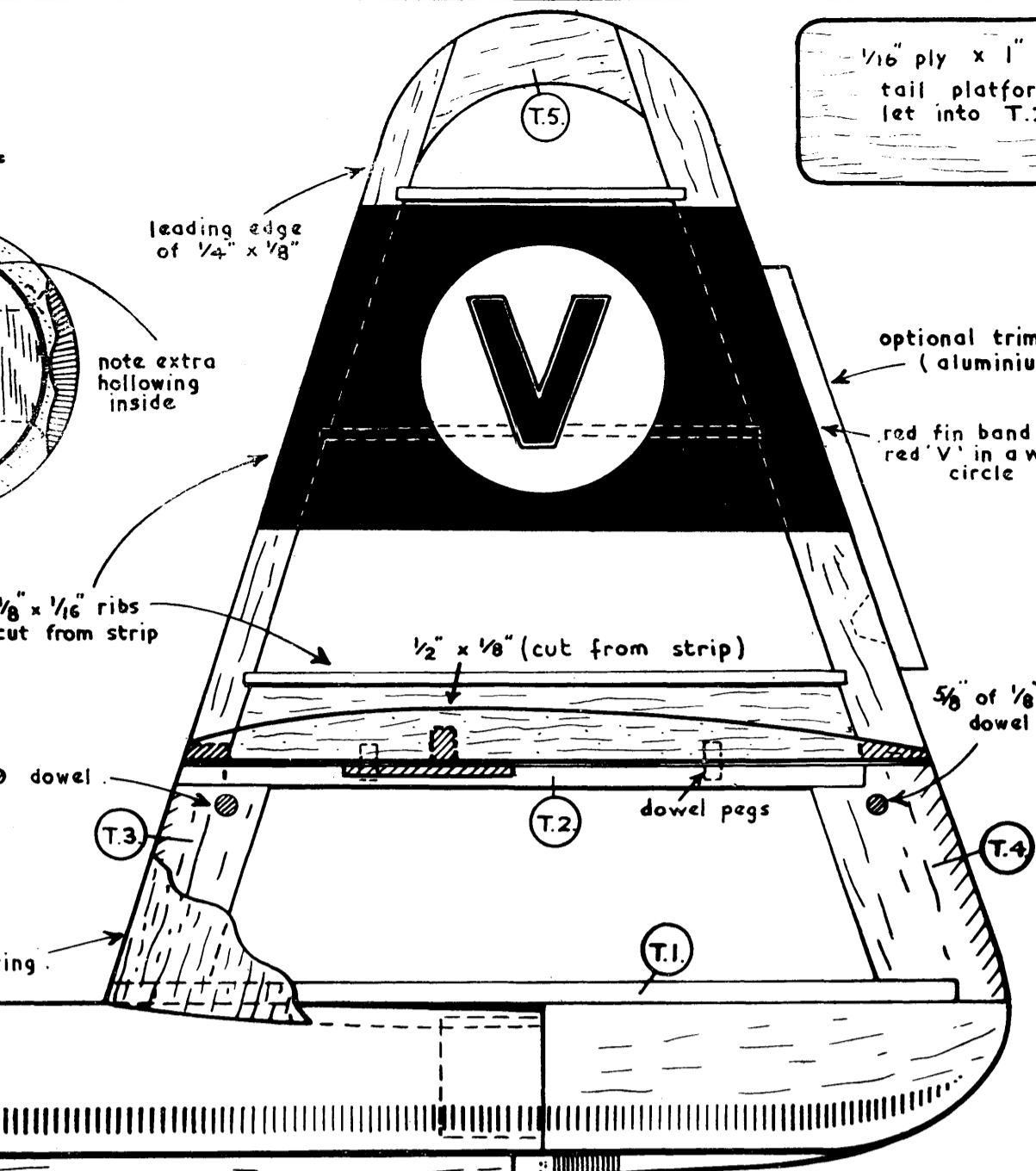
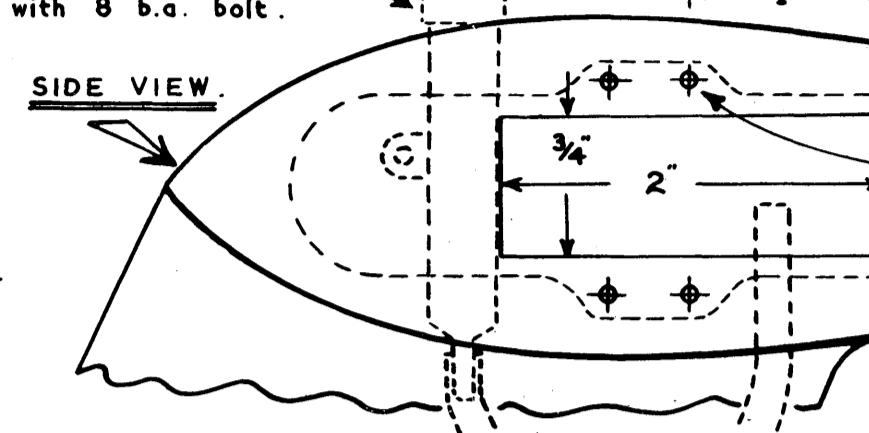
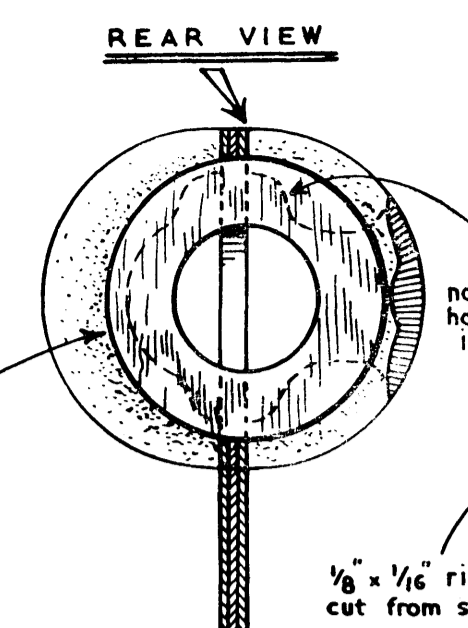
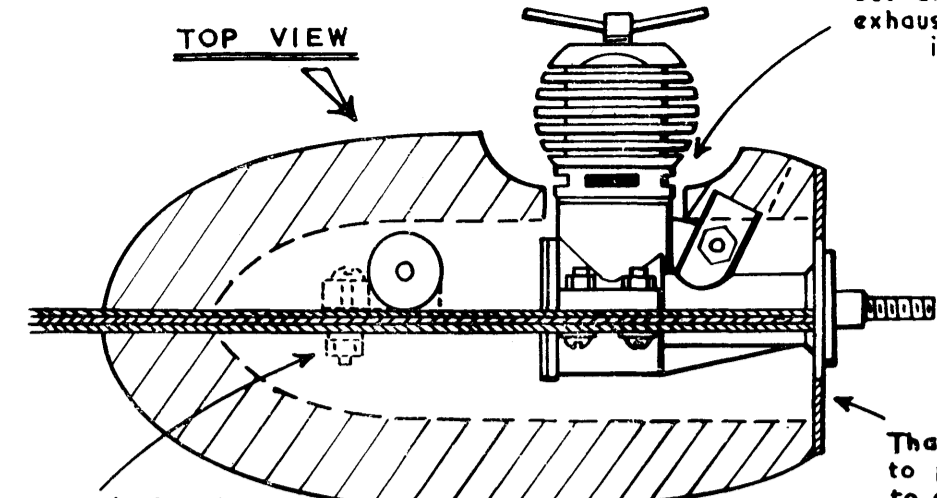

PROPELLERS

A 7" diam. X 4" wooden pusher propeller is suitable for .75 to .9 motors but reduce diameter to 6" for .5 c.c. to .75 motors such as Allbon "Dart".

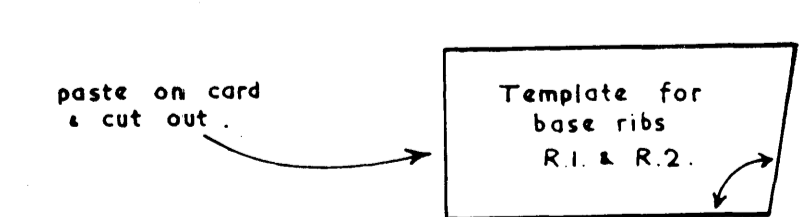
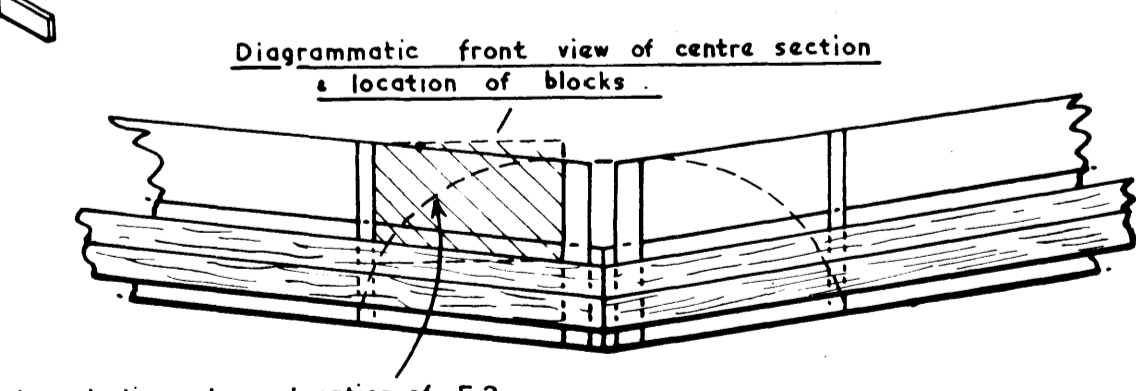

WORLD COPYRIGHT RESERVED BY
by
MODEL AIRCRAFT (B'MTH) LTD.
NORWOOD PLACE, POKESDOWN, BOURNEMOUTH.