

FROG



"MINNOW"

JUNIOR SERIES

12" SPAN RUBBER-POWERED

SIDE VIEW (Full size)

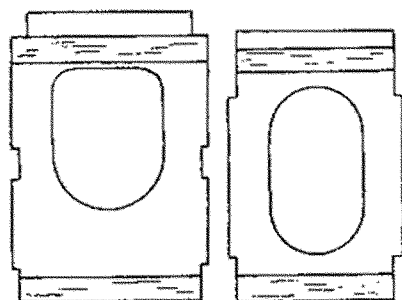
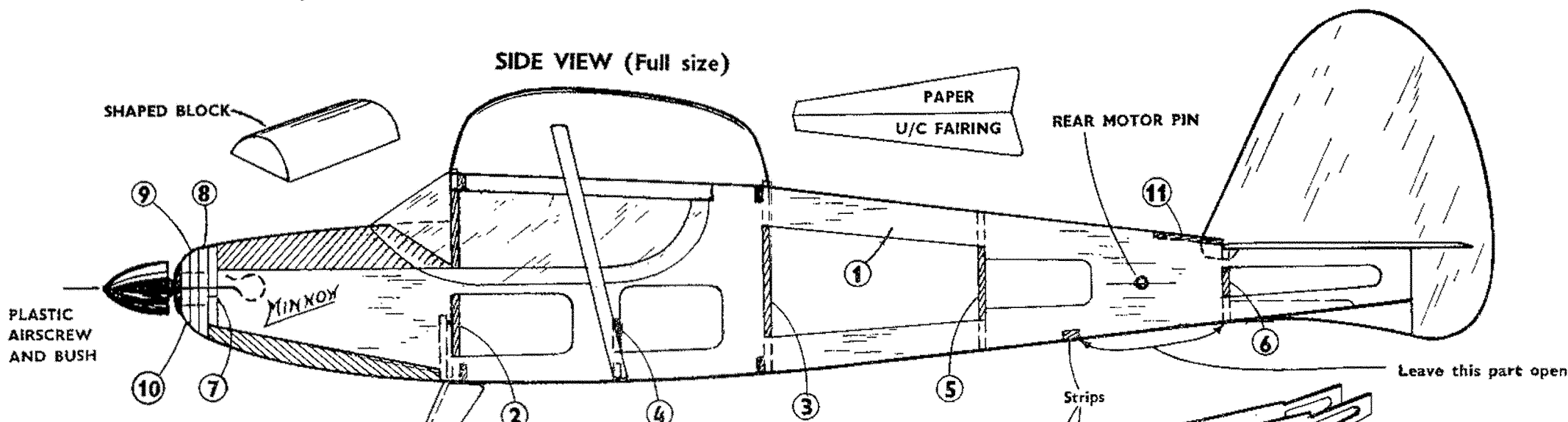

Strips cemented to Bulkheads

PLASTIC WHEELS



FIG. 1

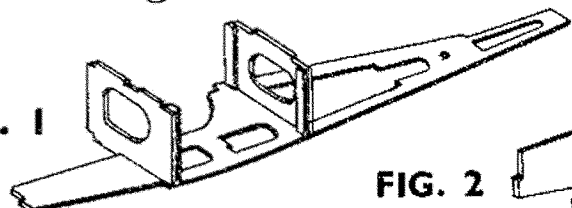

FIG. 4
U/C ASSEMBLY

This piece holds u/c in place.

U/C Wire

FIG. 2

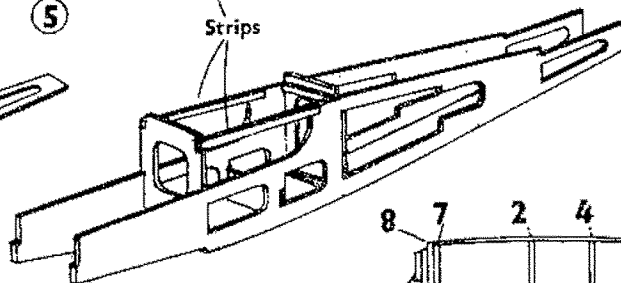

FIG. 5

Cement cabin window at centre first

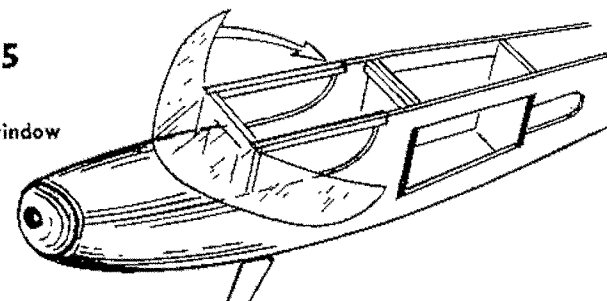
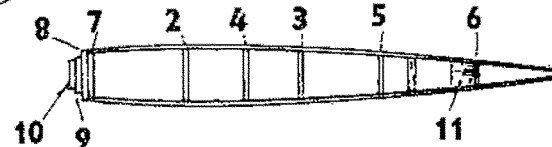

FIG. 3

Top view of fuselage



BUILDING INSTRUCTIONS

The Frog Junior Series comprises a range of models of near-scale design and appearance, and embodying very simple and quick construction methods. All the parts are ready-cut to shape, and interlock together, so that they automatically locate with each other, and only require cementing.

To ensure a satisfactory job, study the plan and check the parts with it before commencing. Assemble the model step by step as shown.

Cement and "dope" are not included in this kit but they can be bought at any model shop. Use quick-drying balsa-cement (glue) such as Frog Universal. You will also need a balsa knife or razor blade and a few pins.

If you have enjoyed building this model, remember there are many others in this series equally attractive.

FUSELAGE ASSEMBLY.

Carefully remove all the parts from the balsa sheet using a balsa knife or a piece of razor-blade to separate them with a clean edge. Start by glueing pieces of the balsa strip supplied to bulkheads 2 and 3, then glue these to one of the side panels, as shown in fig 1. Make sure they are upright, and allow to dry. Then glue the other side in place as in fig. 2. Cut two short pieces from the strip supplied for the top rails. When these are set, assemble the other bulkheads 4, 5, 6 and the front pieces 7, 8, 9 and 10; also the rear piece 11; see fig. 3.

UNDERCARRIAGE.

Bend the top part of the shaped wire piece forward as shown in the side view drawing; then glue it into place in front of bulkhead 2. Cut a piece of balsa to the shape given above, and glue it against the wire to hold it in place; see fig. 4.

Fit the wheels in place and bend the ends of the wire over, or glue small paper washers to the axles to hold them on. Cut the two fairings from paper to the shape given, and glue them to the wire legs.

COWLING.

Fit the lower piece first. Sand-paper the ends to the angle shown in Side View and glue it in place. Shape it after it has set. Glue the top cowlng block in place, and shape the front end to fit the nose.

Glue the cabin window in place next, starting at the centre, see fig. 5, and allow this to set. Then bend the sides round and glue them into place.

Cut a small piece from the strip of balsa, to fit between bulkheads 5 and 6.

Remove any sharp corners with sandpaper and smooth down the whole fuselage to obtain a good finish.

Continued over.

INSTRUCTIONS (cont'd).

COVERING.

Only the fuselage needs covering on this model. Cut four strips of the tissue, to cover each side separately, allowing about $\frac{1}{4}$ in. overlap all round. Use paste for sticking it to the framework. Dope can be used, but remember that it dries very quickly. Start with the bottom and apply paste to the edges of the frame, from the undercarriage to the strip between 5 and 6. Lay the strip of tissue over the frame and smooth out any wrinkles. Do not try and get it drum-tight, as water-shrinking and doping will ensure a taut surface. When dry, trim off the excess paper and paste down again. Repeat this with each side. When the paste is set, spray water carefully over the tissue and allow to dry. A coat of dope or lacquer can be applied to the fuselage to "proof" the surface and strengthen it.

TAIL ASSEMBLY.

Remove the Tailplane and Fin parts from the balsa sheet, using fine sandpaper to obtain a smooth finish. Glue them in place on the fuselage as shown in fig. 6 and make sure they are quite "square" as in fig. 7.

WING.

Sandpaper the edges and smooth down the surface before fixing. Score two lines across the centre as indicated in fig. 8. This is to help bend the wing to the angle required. Place it on a flat board or table, hold down the centre part with weights and raise the tips approx $\frac{5}{8}$ in., see fig. 9. A match box at each tip will give the correct height. Apply cement along the score lines and allow to dry.

When the cement has set, fix the wing in place, with the notches on bulkheads 2 and 3 fitting into the slots in the wing.

The struts are made from the $\frac{1}{8}$ in. x $\frac{3}{32}$ in. strip supplied. Cut two pieces $3\frac{1}{4}$ in. long, sandpaper them to the section shown in fig. 10, and mark the position on the wing from the drawing. Bevel the ends to fit, and cement them in place. Make sure the wing is quite level and free from warps before fixing the struts.

DECORATING.

Painting should be restricted to the fuselage, and edging on the wing and tail, to save weight. Use Cellulose Lacquer, and apply it quickly and evenly with a soft brush. Do not put it on heavily, or the model will not fly well.

Transfers can be affixed to the wing or fin, and any other lettering or decoration required.

MOTOR.

This is an elastic band 6 in. long. Lubricate it with Castor Oil, and insert it with the help of a length of wire or thread. Bend a hook at one end of the wire and insert it into the front end of the fuselage. Hook the band on to it through the opening at the rear, and insert the rear motor pin (cane) through the holes in the fuselage and through the loop of elastic. Pull the band out through the front, and hook it on to the Airscrew shaft (complete with airscrew). The model is now complete and ready for flying. A drop of thin oil on the airscrew shaft will improve the running.

FLYING.

This model can be flown indoors or out, but it should only be used outdoors on a calm day, owing to its size.

Test-glide the model first to check the balance. Hand-launch it in a slight downward direction. If it dives to the ground, carefully bend up the rear edges of the tailplane, known as elevators, or glue a small weight in the rear end of the fuselage. If the model climbs steeply and stalls, bend the elevator down slightly, and/or add a small weight to the nose of the fuselage. A small nail can be pushed into the cowl block for this.

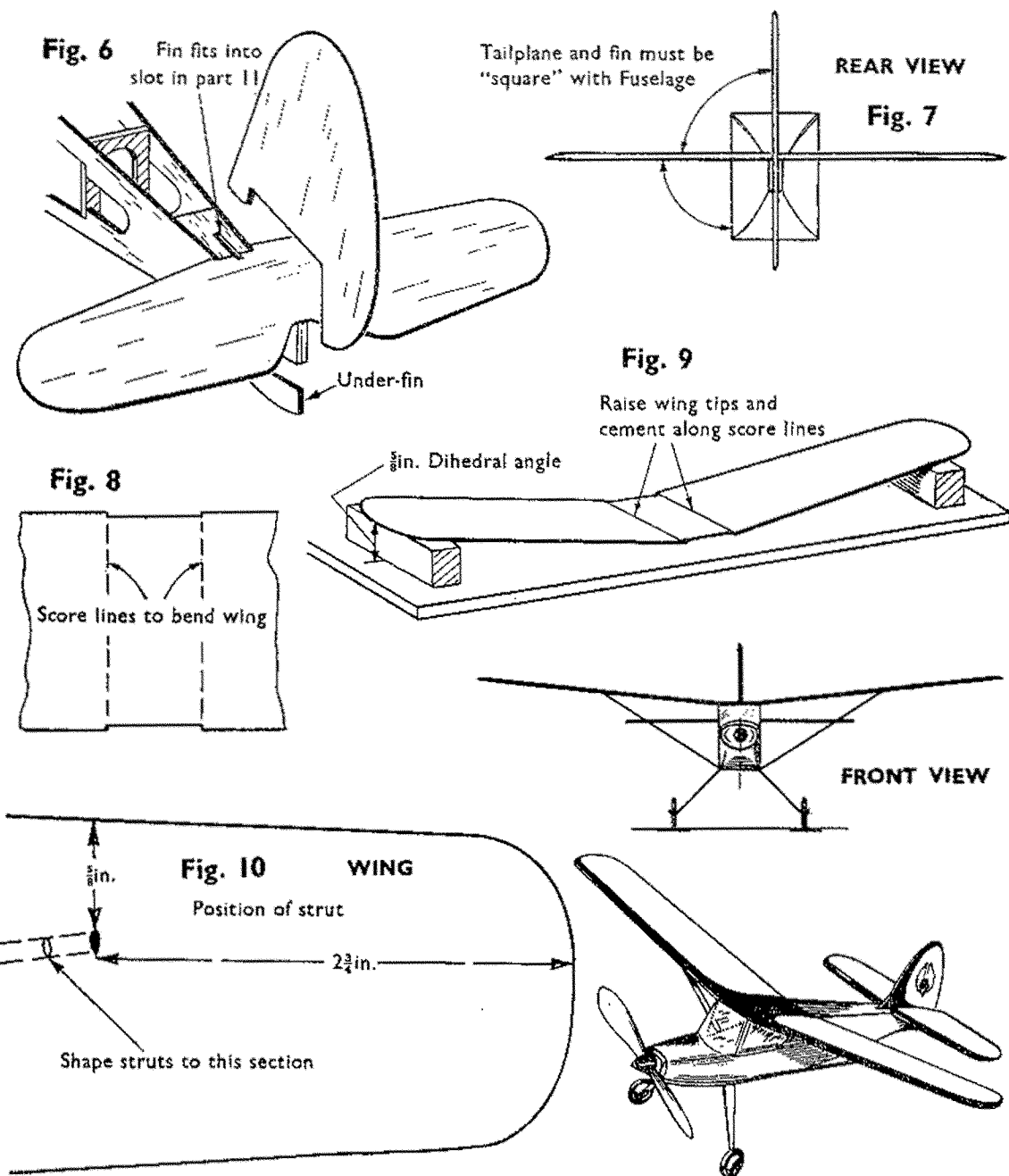

When the glide seems satisfactory, put a few turns on the motor and launch the model (into wind) if any. The turn can be adjusted by bending the fin, or by twisting the wing slightly.

Increase the turns on the motor gradually, up to a maximum of approximately 300; if the motor is not lubricated, the turns must be limited to 150.

Designed and Made in England by
INTERNATIONAL MODEL AIRCRAFT LTD.
 MORDEN ROAD, MERTON, LONDON, S.W.19.

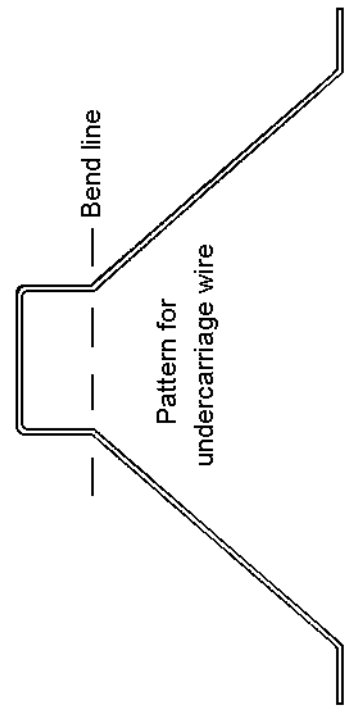
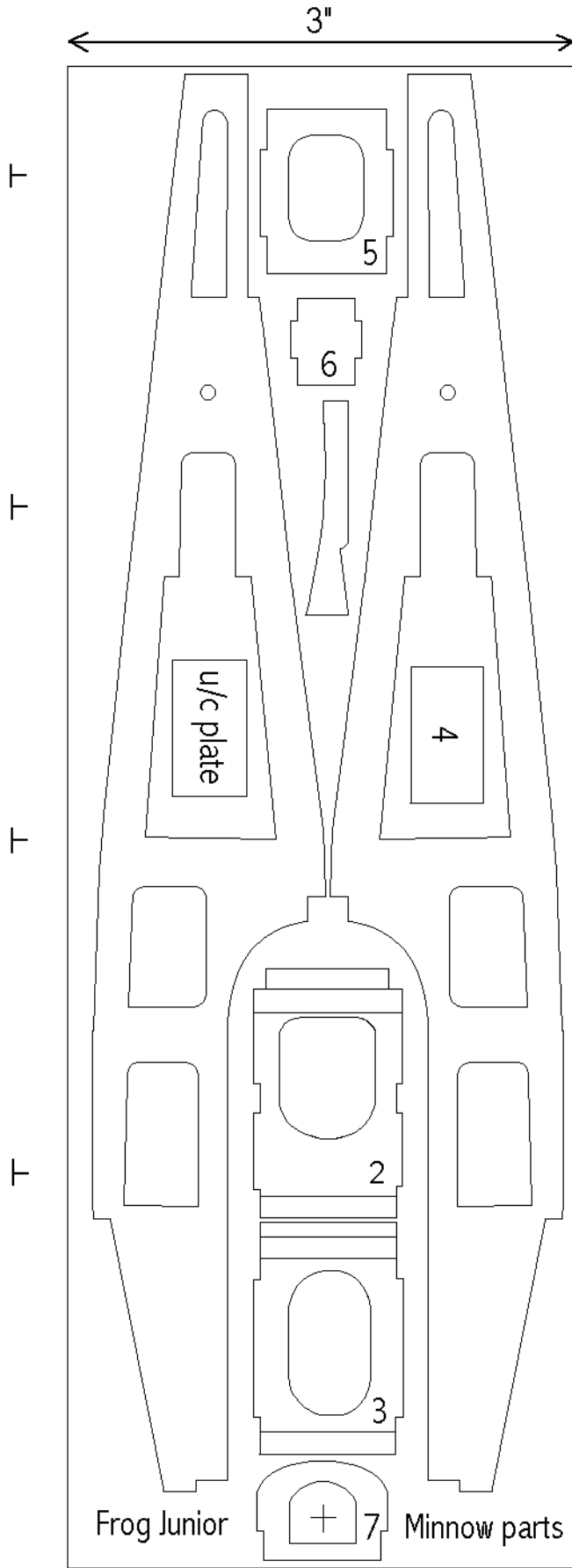

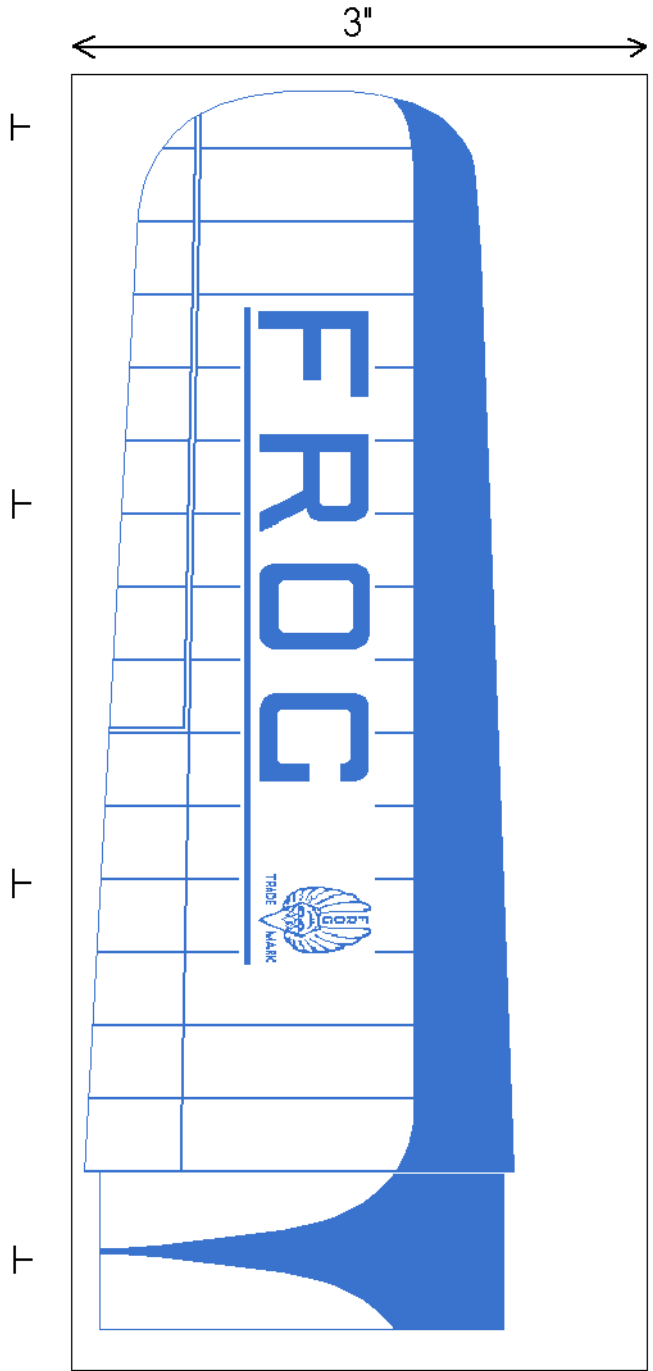

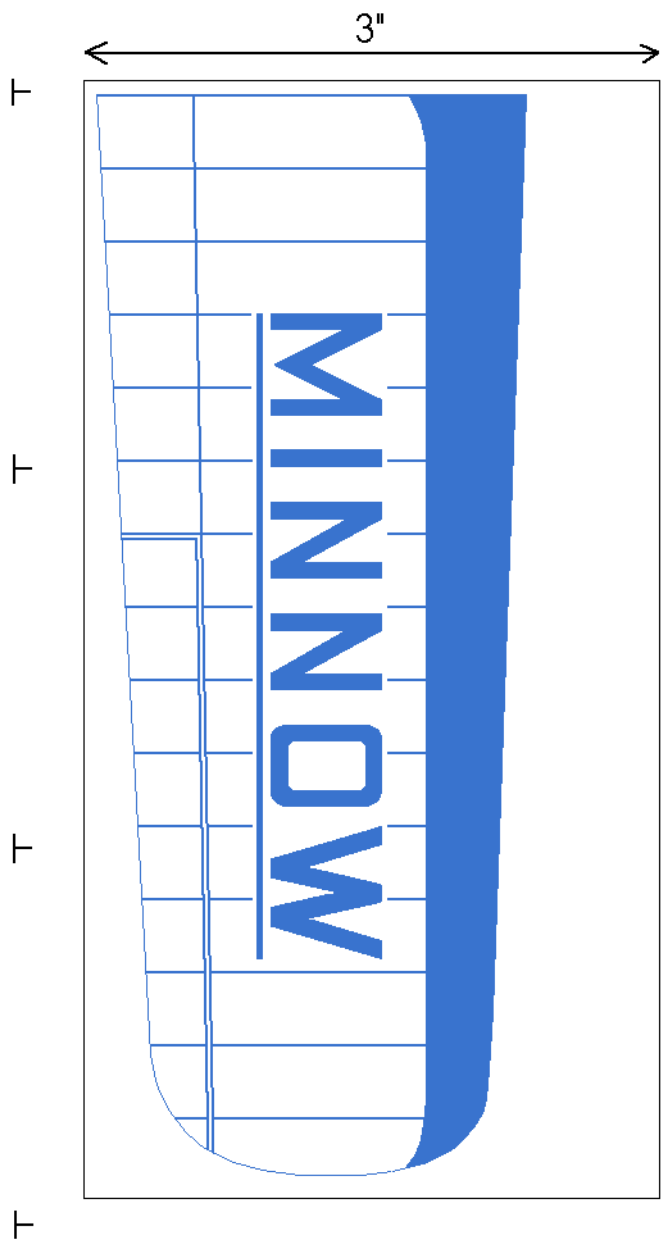

3"

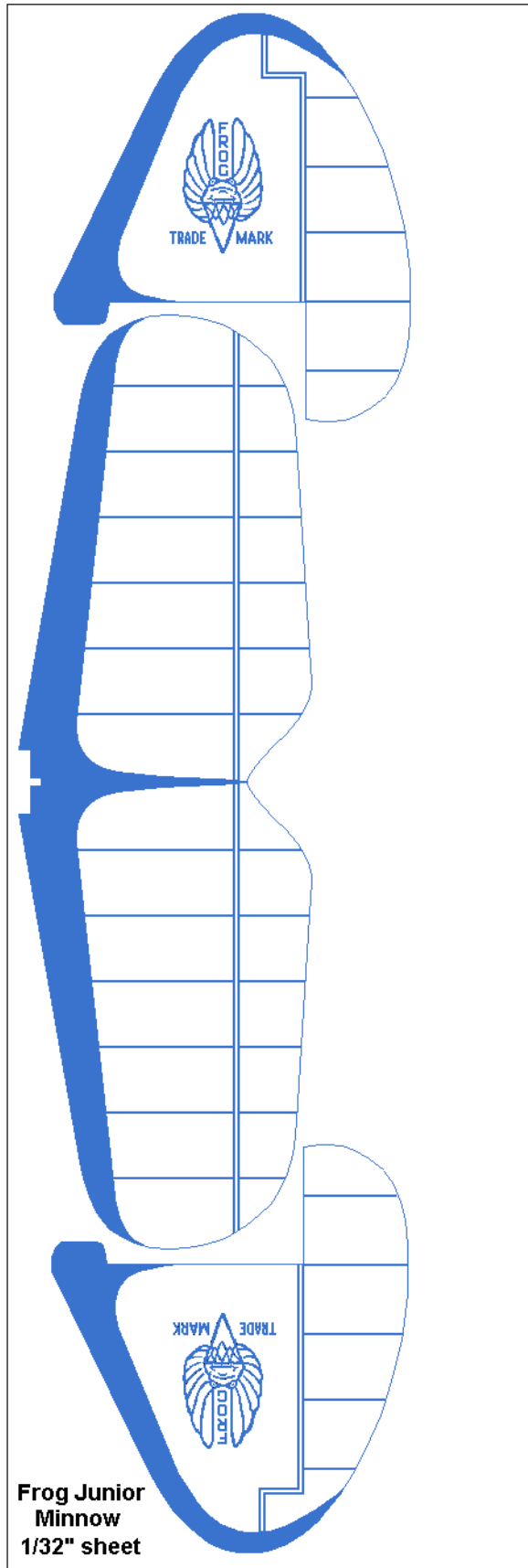

**Frog Junior
Minnow
1/32" sheet**