

# HALES 'MINI' SERIES B.A. SWALLOW

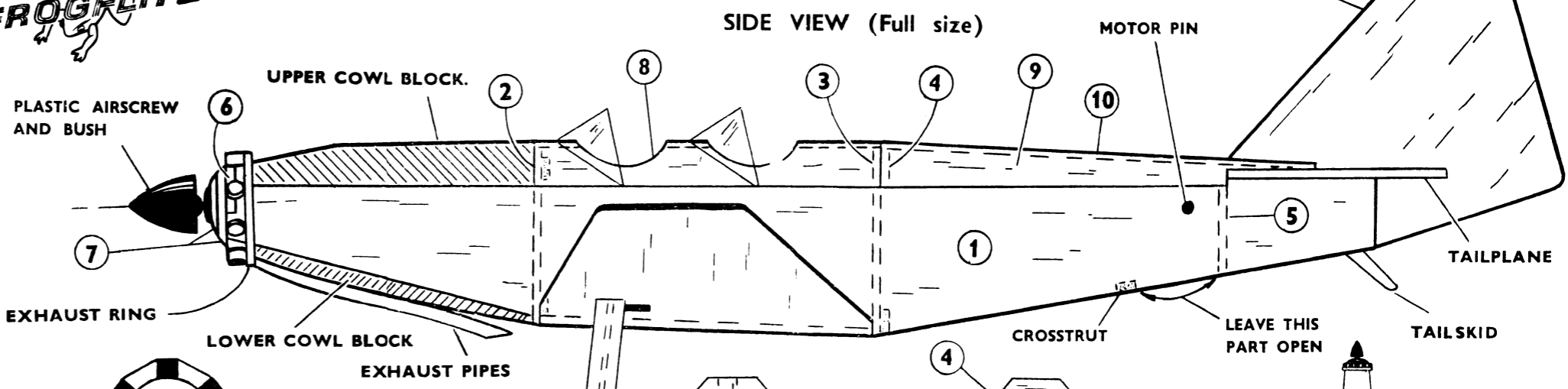
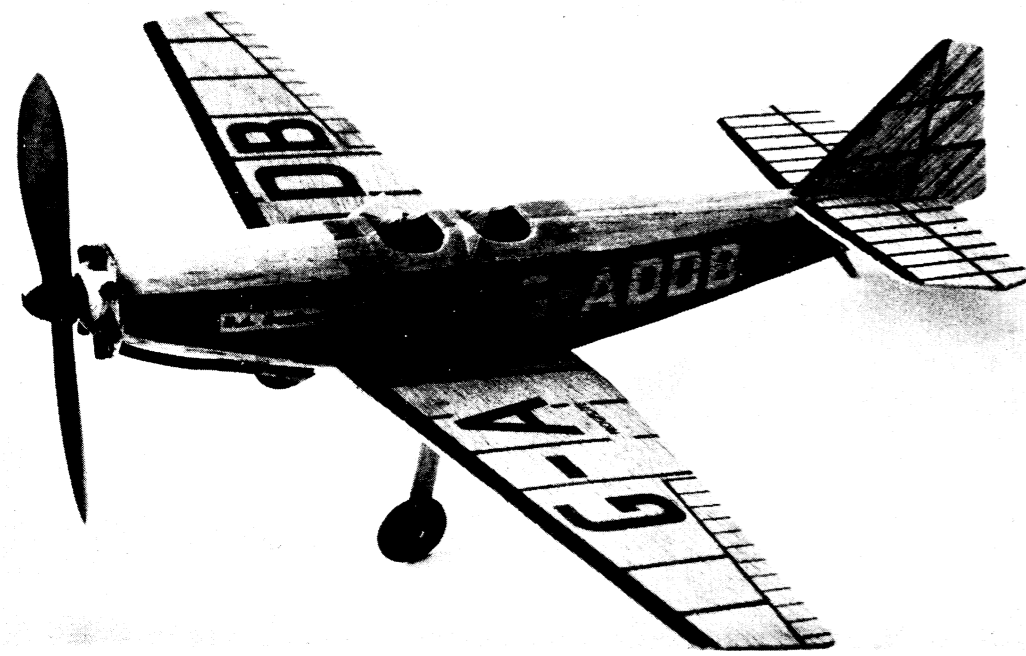

## INTRODUCTION

This is one of a series of twelve models in the FROGLITE 'MINI' range of scale and semi-scale aircraft. To ensure the best job of assembly, study the plan and read the instructions through before cementing any parts together. Most of the parts are supplied already cut to shape, but to remove from the sheet panels cut through carefully at the 'ties' with a razor blade or modelling knife—do not push out.

## FUSELAGE ASSEMBLY.

Carefully remove all parts from the balsa sheet using a balsa knife or a piece of razor blade to separate them with a clean edge. Start by cementing pieces of balsa strip cut from scrap to bulkheads 2 and 3 (cement part 4 to bulkhead 3) and cement these to one of the side panels 1, as shown in fig. 1. Make sure they are upright, and allow to dry. Then cement the other side in place with bulkheads 5 and 6 as in fig. 2.

## COWLING.

Sandpaper the ends of the lower block to the angle shown in Side View and cement it into place. Then cement parts 7 to the front of the fuselage. Remove parts 8 from the balsa sheet and cement them in place on bulkheads 2 and 3. The spaces between parts 8 are filled in with spare sheet balsa. See fig. 3. Fit the top cowl block in place between bulkheads 2 and 6. The underside should be cut away to allow more freedom for the elastic motor. Shape the blocks with a sharp knife or razor blade, and sandpaper them smooth. Cut cross-strut from spare balsa sheet and cement it in place in front of bulkhead 5. See Side View.

## ENGINE AND EXHAUST PIPES.

Cut out Exhaust ring shape from the drawing and cement it to a piece of spare sheet balsa. When this has set, cut it to shape and sandpaper it to fit the nose of the fuselage in the position shown on the Side View drawing and cement it in place. Sandpaper the long square strip to a rounded section and cut off 7 pieces  $\frac{1}{4}$ " long and cement them in positions shown on exhaust ring. Cut what is left of the strip of balsa into two, sandpaper one end of each piece to angle shown on side view and cement to underside of fuselage, fig. 4.

## Fig. 5 TAIL ASSEMBLY.

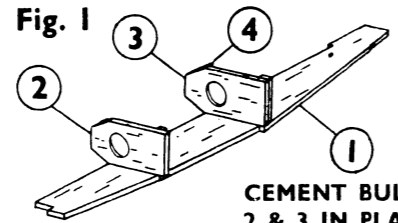
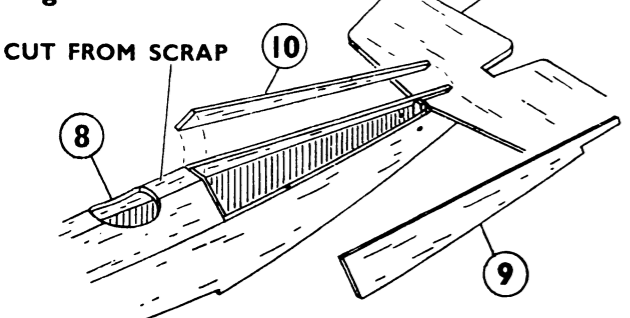

CEMENT BULKHEADS 2 & 3 IN PLACE FIRST

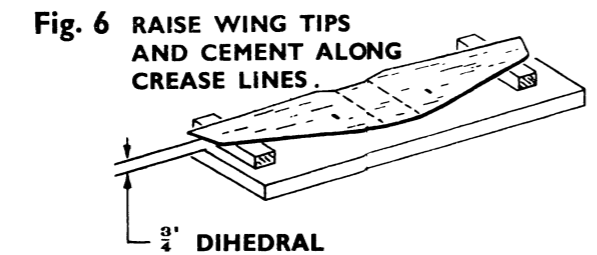
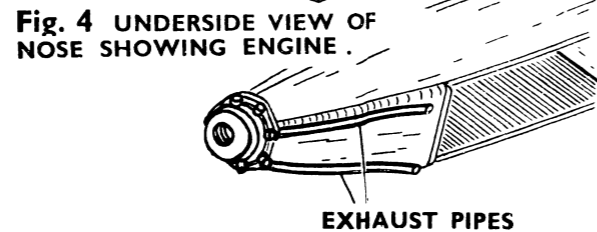
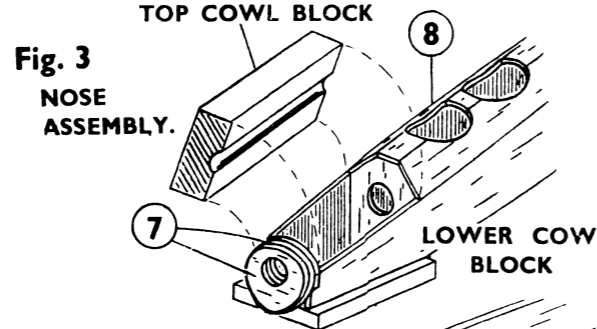
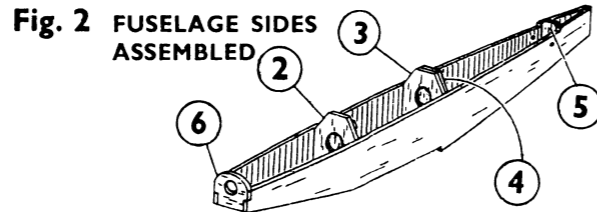

## TAIL ASSEMBLY.

Lightly sandpaper the edges of the Tailplane and cement it in place on the fuselage, making sure it is quite "square" with it when viewed from either end.

Sandpaper the edges of part 9 to fit the fuselage and cement them in position. Then fix part 10 on top of them. See fig. 5. Sandpaper these parts, leaving the four edges sharp. The fin can now be cemented in place.

## WINDSCREENS

Cut out the two windscreens from acetate sheet. Cement these in place on the fuselage as shown on Side View drawing.

## WING.

Remove the cut-out wing from the panel, and sandpaper the edges smooth. Place it on a flat board or table, hold down the centre part with weights or pins and raise the tips approx.  $\frac{3}{4}$ " in. as in fig. 6. Apply cement along crease lines and allow to dry. When this has set, cement it into place on the bottom of the fuselage

## UNDERCARRIAGE.

Bend undercarriage legs to the shape given in fig 7. Cement the undercarriage fairings into the slots in the wing, making sure they are "square" with it. When they have set, fix the undercarriage legs in place as in fig. 8. Small tabs of paper can be cemented over the wires to secure them. Fit the wheels in place and bend over the ends of the wires, or glue small paper washers to the axles to hold them on.

## COVERING.

Cover the bottom of the fuselage between bulkhead 3 and cross-strut, with a piece of tissue attached with cement or clear dope.

## DECORATING.

The balsa wood parts being ready printed, very little painting is necessary and should be restricted to a black anti-glare strip on the top of the fuselage forward of the cockpit. Use Cellulose Lacquer and apply it quickly and evenly with a soft brush. Do not put it on heavily, or the model will not fly well.

## MOTOR.

This is an elastic band 6" long. Lubricate it well with Rubber Lubricant, or Castor Oil, and insert it with the help of a length of wire or thread. Bend a hook at one end of the wire and insert it into the front end of the fuselage. Hook the band on to it through the opening at the rear, and insert the rear motor pin (cane) through the holes in the fuselage and through the loop of elastic. Pull the band out through the front and hook it on to the Airscrew shaft (complete with air-screw). The model is now complete and ready for flying. A drop of thin oil on the air-screw shaft will improve the running.

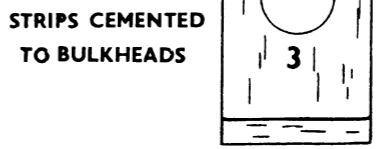

Fig. 7 U/C LEGS BENT TO SHAPE

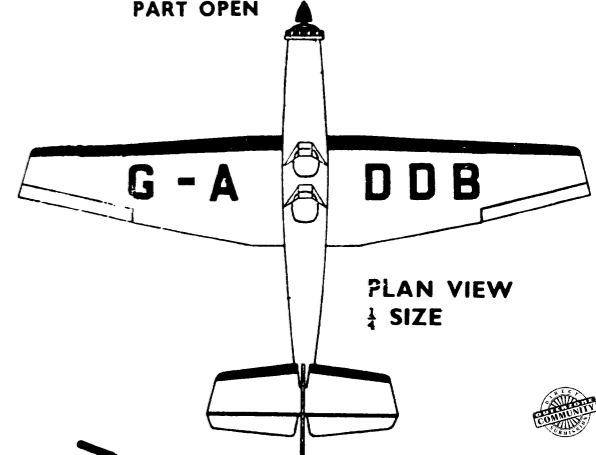
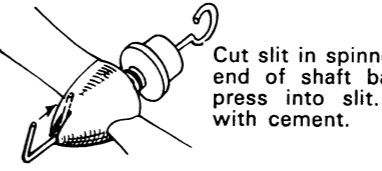
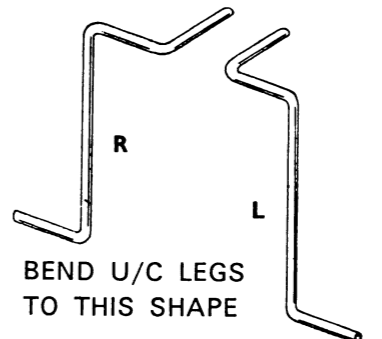

Fig. 8 UNDERSIDE VIEW OF WING SHOWING U/C FIXING

## FLYING.

This model can be flown indoors or out, but it should only be used out-doors on a calm day, owing to its size.

A slight difference in balance may be shown with each individual model, owing to the varied density and weight of balsa wood.

Test-glide the model first to check the balance. Hand-launch it in a slight downward direction. If it dives to the ground, add a small weight such as a small nail or pin to the rear end of the fuselage. If the model climbs steeply and stalls, add a small weight to the nose of the fuselage. A small nail or drawing pin can be pushed into the cowl block for this.

When the glide seems satisfactory, put a few turns on the motor and launch the model into wind (if any). The turn can be adjusted by bending the fin, or by twisting the wing slightly.

Increase the turns on the motor gradually, up to a maximum of approximately 300; if the motor is not lubricated, the turns must be limited to approximately 150.

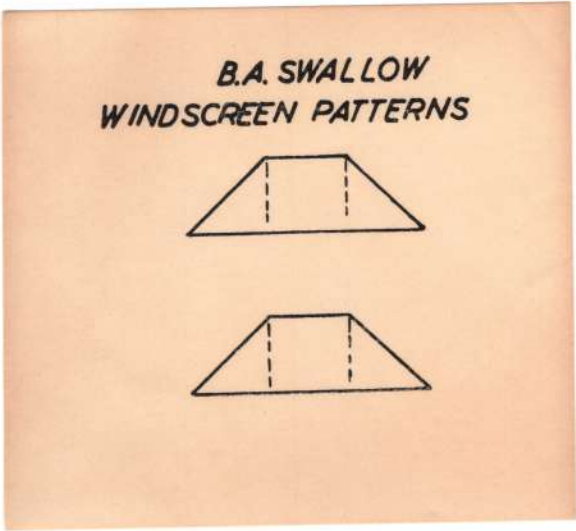
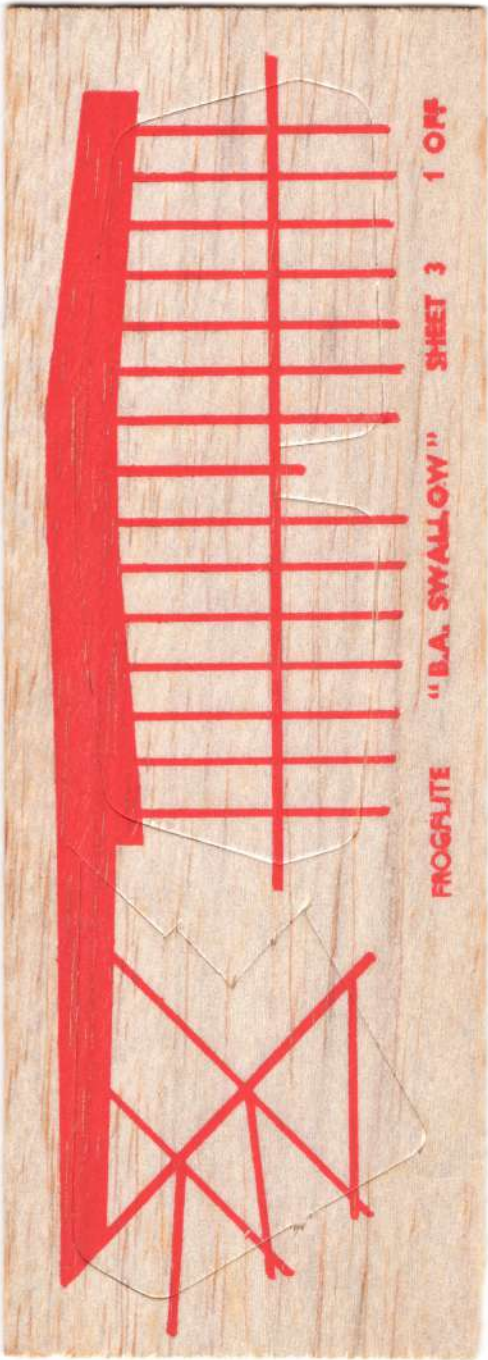

FROGLITE

"B.A. SWALLOW"

SHEET 2

1 OFF

FROGLITE

G-A

"B.A. SWALLOW"

DDB

G-A DDB

BDDA-5

B.A. Swallow

B.A. Swallow

2

2

8

8

10



10

FROGLITE

"B.A. SWALLOW"

10

SHEET 1 1 OFF