

FROG

TRADE MARK

"AUSTER" A.O.P. 9

JUNIOR
SCALE
SERIES

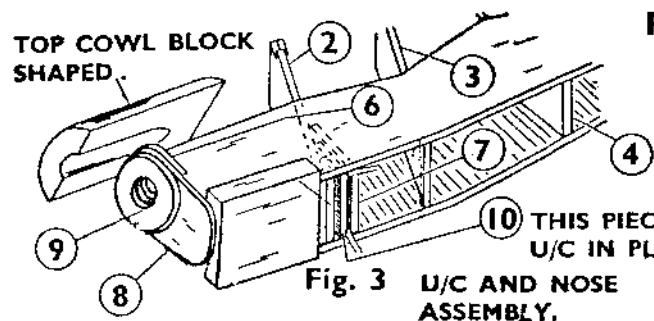
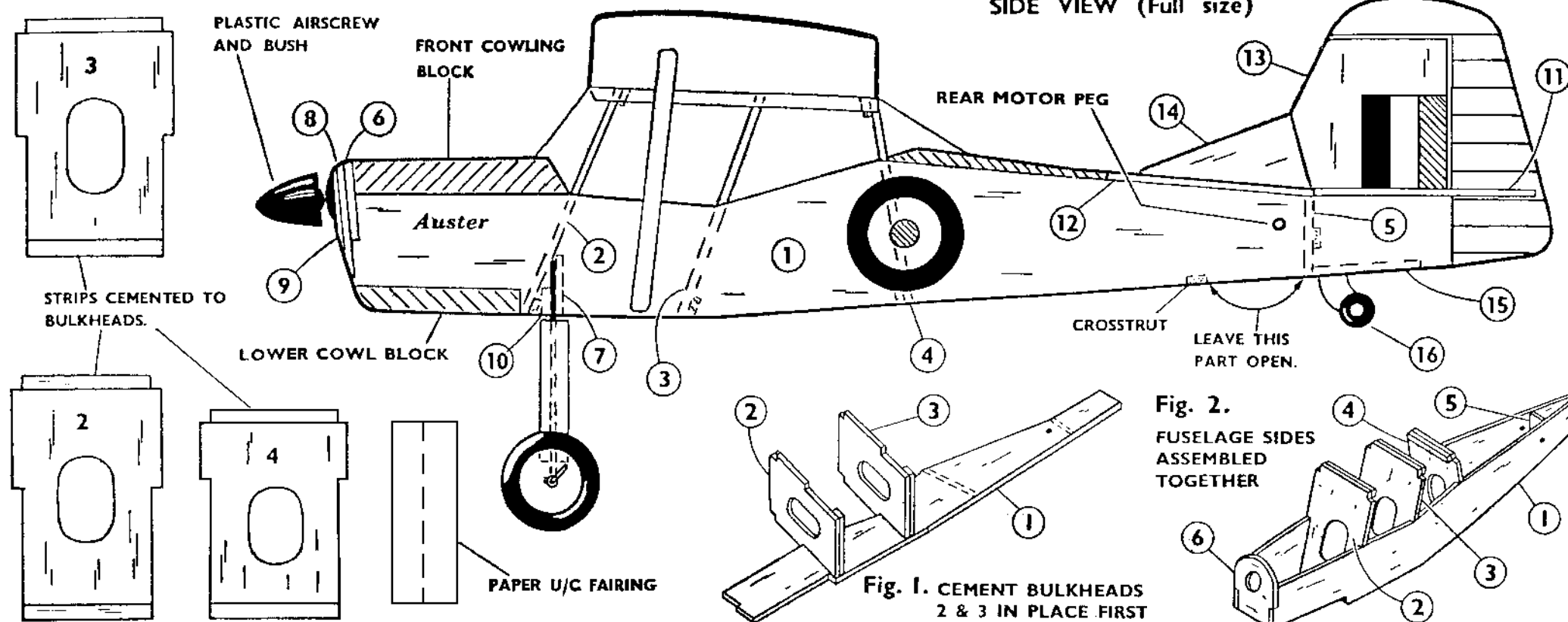
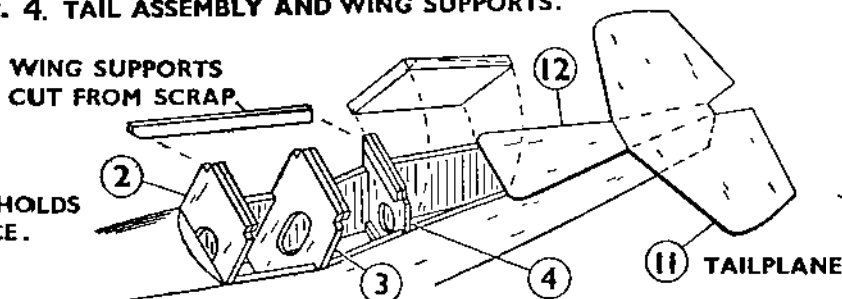

Fig. 3 U/C AND NOSE ASSEMBLY.

Fig. 4. TAIL ASSEMBLY AND WING SUPPORTS.



BUILDING INSTRUCTIONS

FUSELAGE ASSEMBLY.

Carefully remove all the parts from the balsa sheet using a balsa knife or a piece of razor-blade to separate them with a clean edge. Start by marking the bulkhead positions on the side pieces 1 from the side-view drawing. Then cement pieces of balsa strip cut from scrap, to bulkheads 2, 3 and 4, and cement these to one of the side panels as shown in fig. 1. Make sure they are upright, and allow to dry. Then cement the other side in place with bulkheads 4, 5 and 6, as in fig. 2. Cement bulkhead 7 in place behind bulkhead 2.

COWLING.

Sandpaper the ends of the lower block to the angles shown in Side View, and cement it into place. Then cement parts 8 and 9 to the front of the fuselage, and fit the top cowling piece in place. Shape the blocks with a sharp knife or razor blade, and sandpaper them smooth.

Fig. 2.
FUSELAGE SIDES
ASSEMBLED
TOGETHER

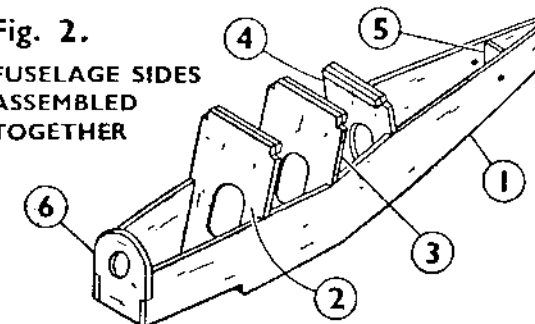
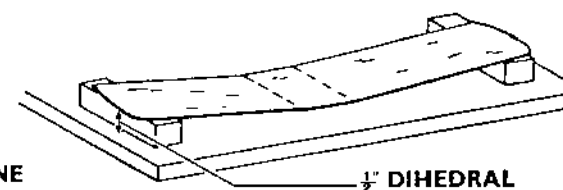

Fig. 5 RAISE WING TIPS AND CEMENT ALONG CREASE LINES.



UNDERCARRIAGE.

Cement the shaped wire piece in front of bulkhead 7. This is held in place by piece 10, well cemented over the wire, fig. 3.

TAIL ASSEMBLY.

Remove the Tailplane 11, part 12, and Fin parts 13 and 14, from the balsa sheet and lightly sandpaper the edges. Cement them in place on the fuselage, and make sure they are quite "square" with it when viewed on end. The rear block may now be cemented behind bulkhead 4. When this is set, shape it as shown in fig. 4. Cut two wing supports from spare balsa sheet to the shape given on Side View. Cement these in place on bulkheads 2, 3 and 4.

Cement parts 15 and 16 to the fuselage.

Fit the wheels in place and bend the ends of the wire over, or fix small paper washers to the axles to hold them on. Cut the two fairings from paper to the shape given, and cement them to the wire legs.

INTRODUCTION.

The Frog Junior Scale Series covers a range of models which are based on the designs of various service and light aircraft.

In common with other Frog models, they embody very simple construction methods having all the parts cut to shape, which only require cementing together.

To ensure a satisfactory job, study the plan and check the parts with it before commencing. Assemble the model step by step as shown.

Cement and "dope" are not included in this kit, but they can be bought at any model shop. Use quick-drying balsacem (glue) such as Frog Universal. You will also need a balsa knife or razor blade and a few pins.

If you enjoy building this model, remember there are many others in this series equally attractive.



"AUSTER" A.O.P. 9

CAT. No. 582FK.

INSTRUCTIONS (contd.).

WING.

Remove the cut out wing from the panel and lightly sandpaper the edges. Place it on a flat board or table, hold down the centre part with weights and raise the tips approximately $\frac{1}{2}$ in., see fig. 5. Apply cement along crease lines and allow to dry. When this has set, cement the wing in place over bulkheads 2, 3 and 4.

The struts are made from spare balsa sheet. Cut 2 pieces 4 in. long, sandpaper them and bevel the ends to fit. Cement them in place as shown on Side View drawing.

CABIN WINDOWS.

Cement the front cabin window (Large one) in place, starting at the centre, see fig. 6, and allow this to set. Then bend the sides round and fix them into place. Cement the rear cabin window in the same manner.

COVERING.

The bottom of the fuselage from part 10 to the cross strut, is covered with thin note paper. Cut a piece about $4\frac{1}{2}$ in. long and $1\frac{1}{2}$ in. wide, and cement it into place, on the fuselage. When this has set, trim off the excess paper with a razor blade.

DECORATING.

The balsa wood parts being ready printed, very little, if any, painting is necessary, and should be restricted to the top part of the fuselage.

Use Cellulose Lacquer, and apply it quickly and evenly with a soft brush. Do not put it on heavily, or the model will not fly well.

MOTOR.

This is an elastic band 6 in. long. Lubricate it with Frog Rubber Lubricant, or Castor Oil, and insert it with the help of a length of wire or thread. Bend a hook at one end of the wire and insert it into the front end of the fuselage. Hook the band on to it through the opening at the rear, and insert the rear motor pin (cane) through the holes in the fuselage and through the loop of elastic. Pull the band out through the front, and hook it on to the Airscrew shaft (complete with airscrew). The model is now complete and ready for flying. A drop of thin oil on the airscrew shaft will improve the running.

FLYING.

This model can be flown indoors or out, but it should only be used out-doors on a calm day, owing to its size.

A slight difference in balance may be shown with each individual model, owing to the varied density and weight of balsa wood.

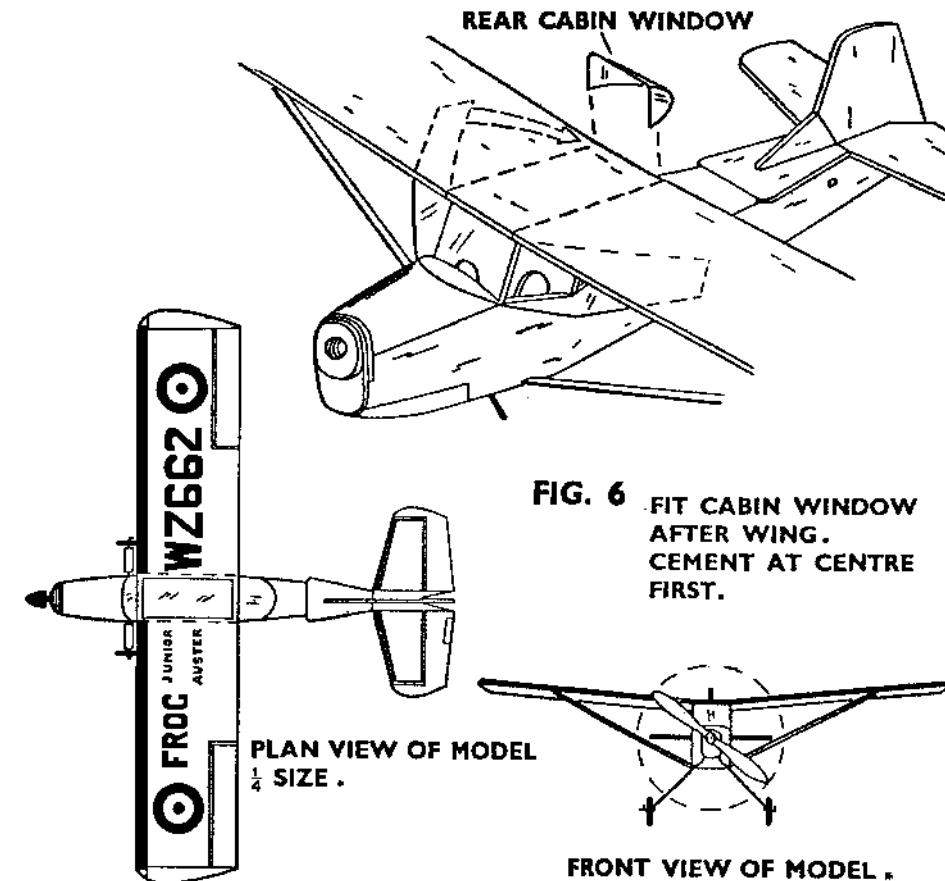

Test-glide the model first to check the balance. Hand-launch it in a slight downward direction. If it dives to the ground, add a small weight such as a small nail or pin to the rear end of the fuselage. If the model climbs steeply and stalls, add a small weight to the nose of the fuselage. A small nail or drawing pin can be pushed into the cowl block for this.

When the glide seems satisfactory, put a few turns on the motor and launch the model into wind (if any). The turn can be adjusted by bending the fin, or by twisting the wing slightly.

Increase the turns on the motor gradually, up to a maximum of approximately 300; if the motor is not lubricated, the turns must be limited to approximately 150.

Designed and Made in England by
INTERNATIONAL MODEL AIRCRAFT LTD.
MORDEN ROAD, MERTON, LONDON, S.W.19.

PRINTED IN ENGLAND.

150
100
50
0
mm

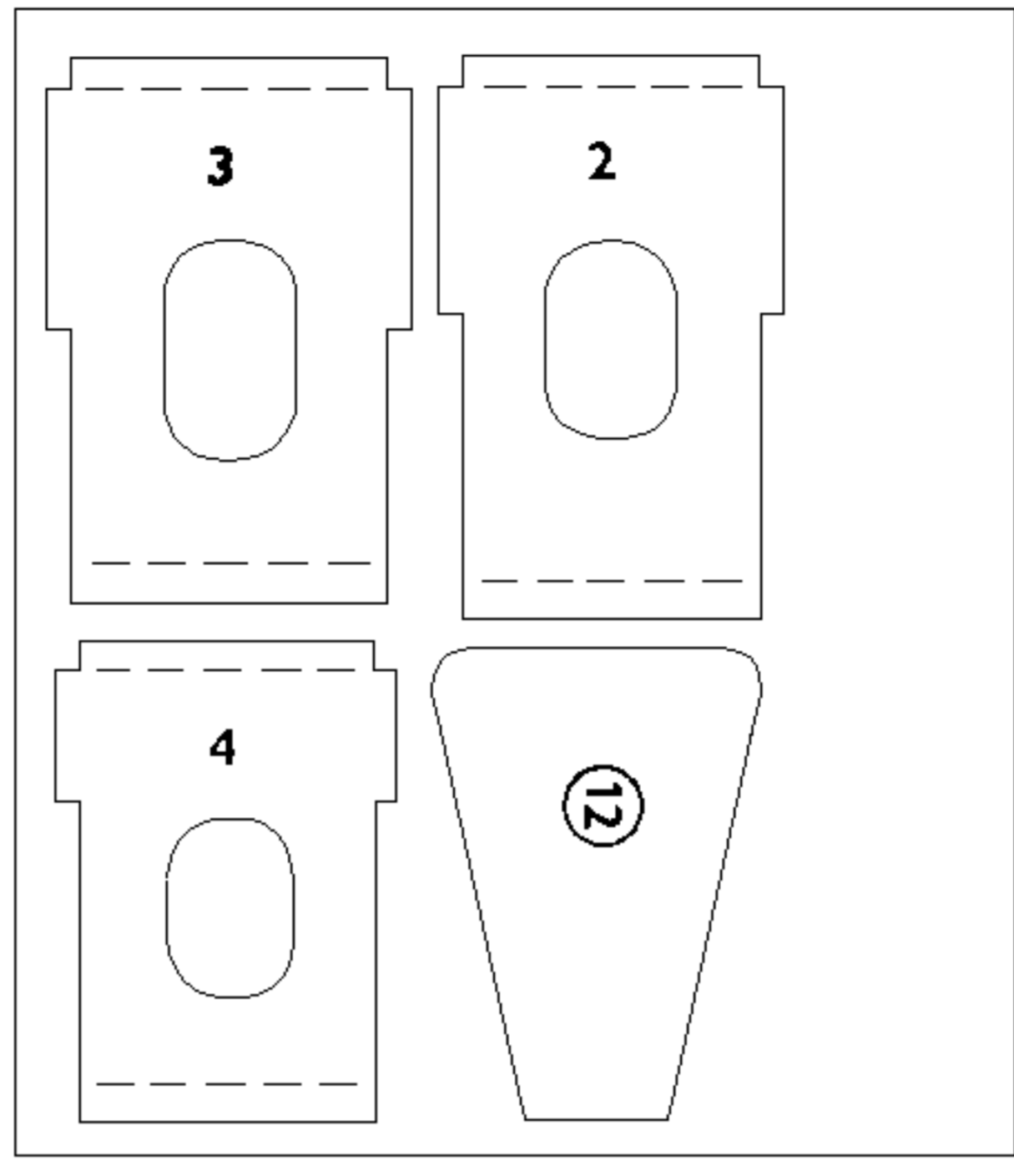

150
100
mm
50
0

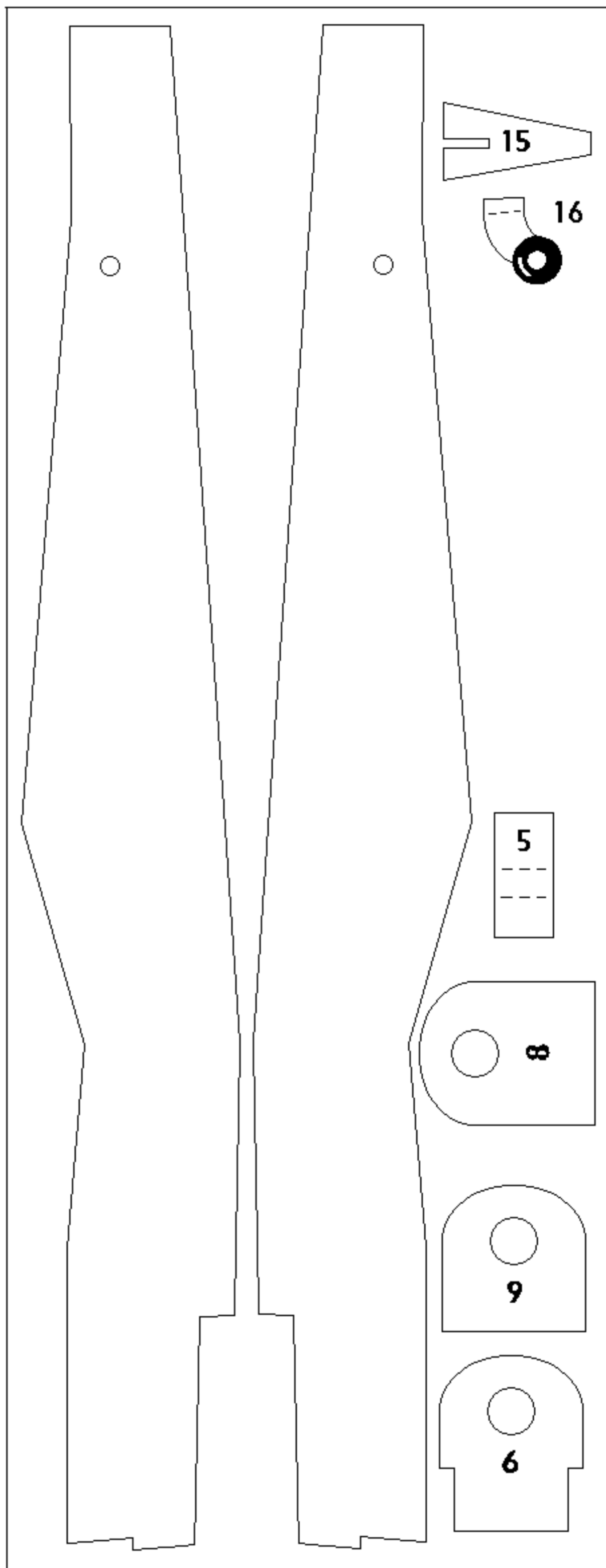

0 50 100 150 mm

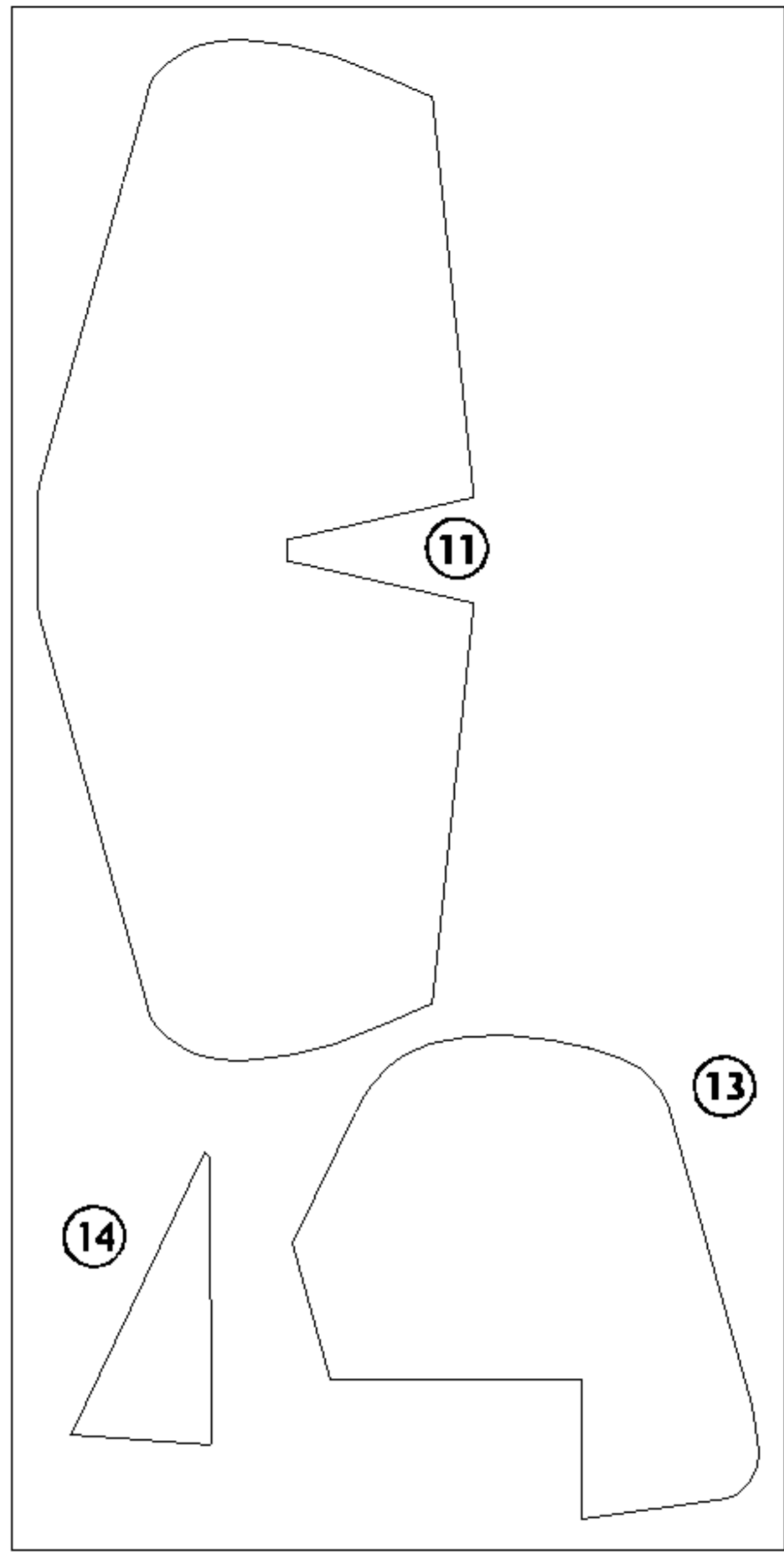

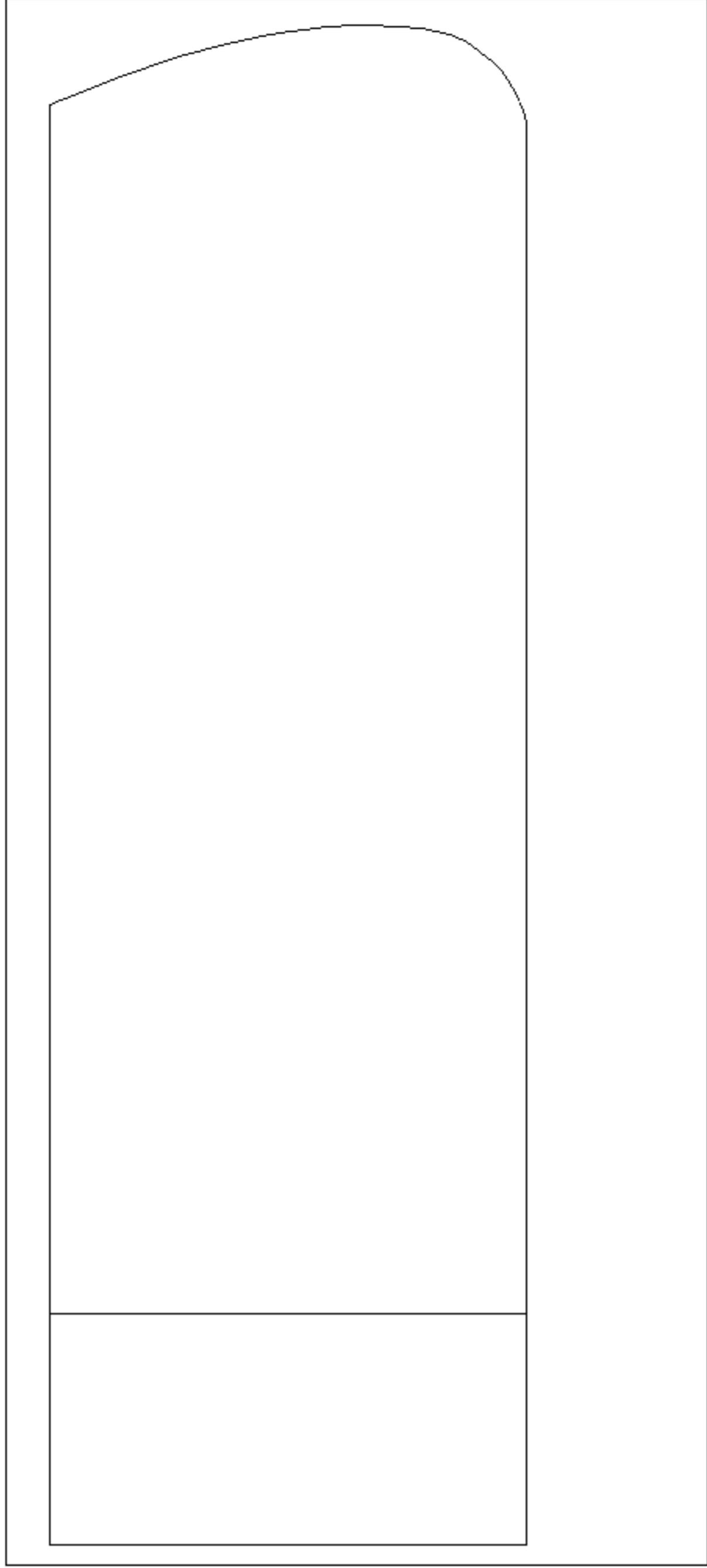

150
100
mm
50
0

