

INSTRUMENTS SHOWN AS MODEL SCALE. Reduce size by 5x and set DPI at 1200. Use to print instrument faces on paper or metal plate.

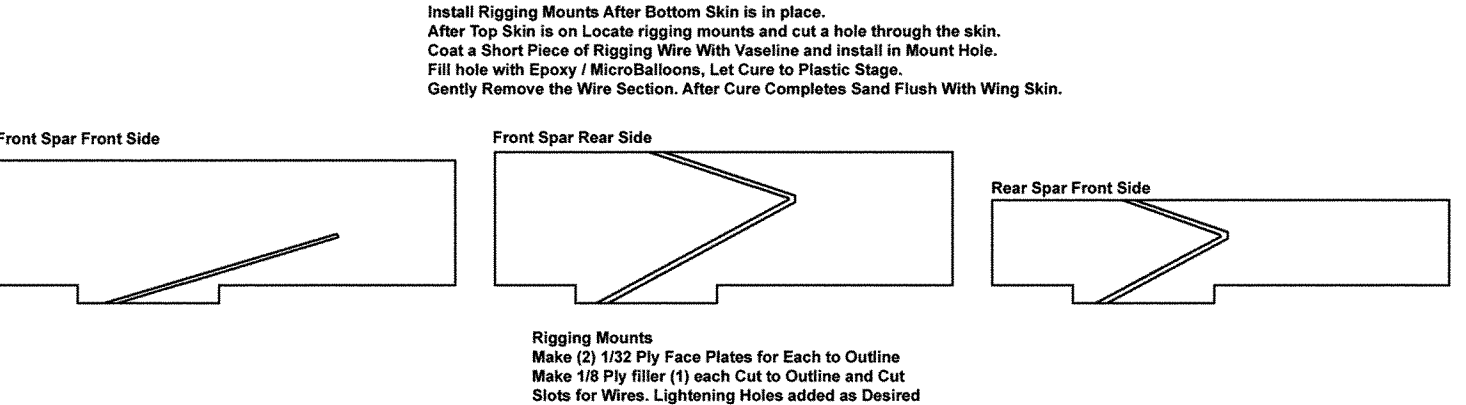
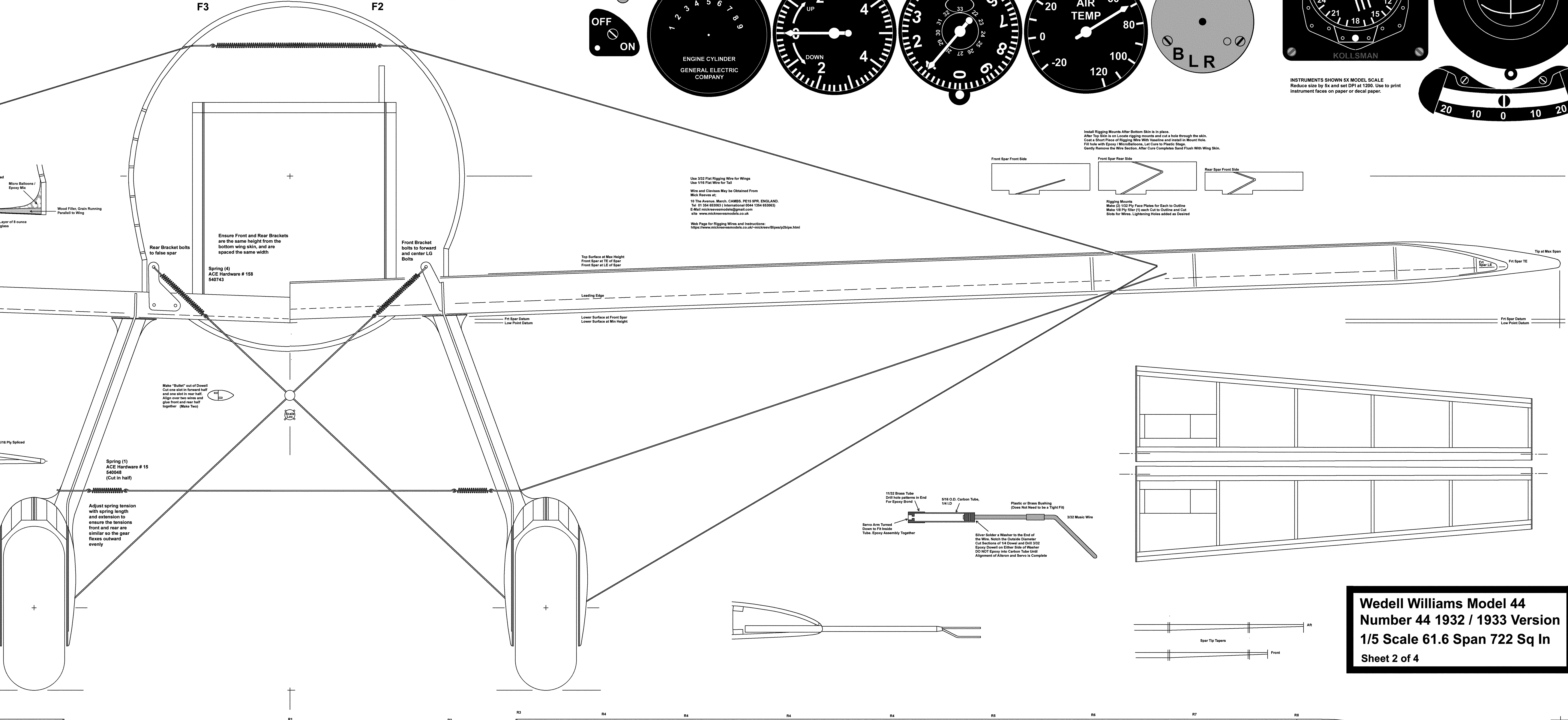
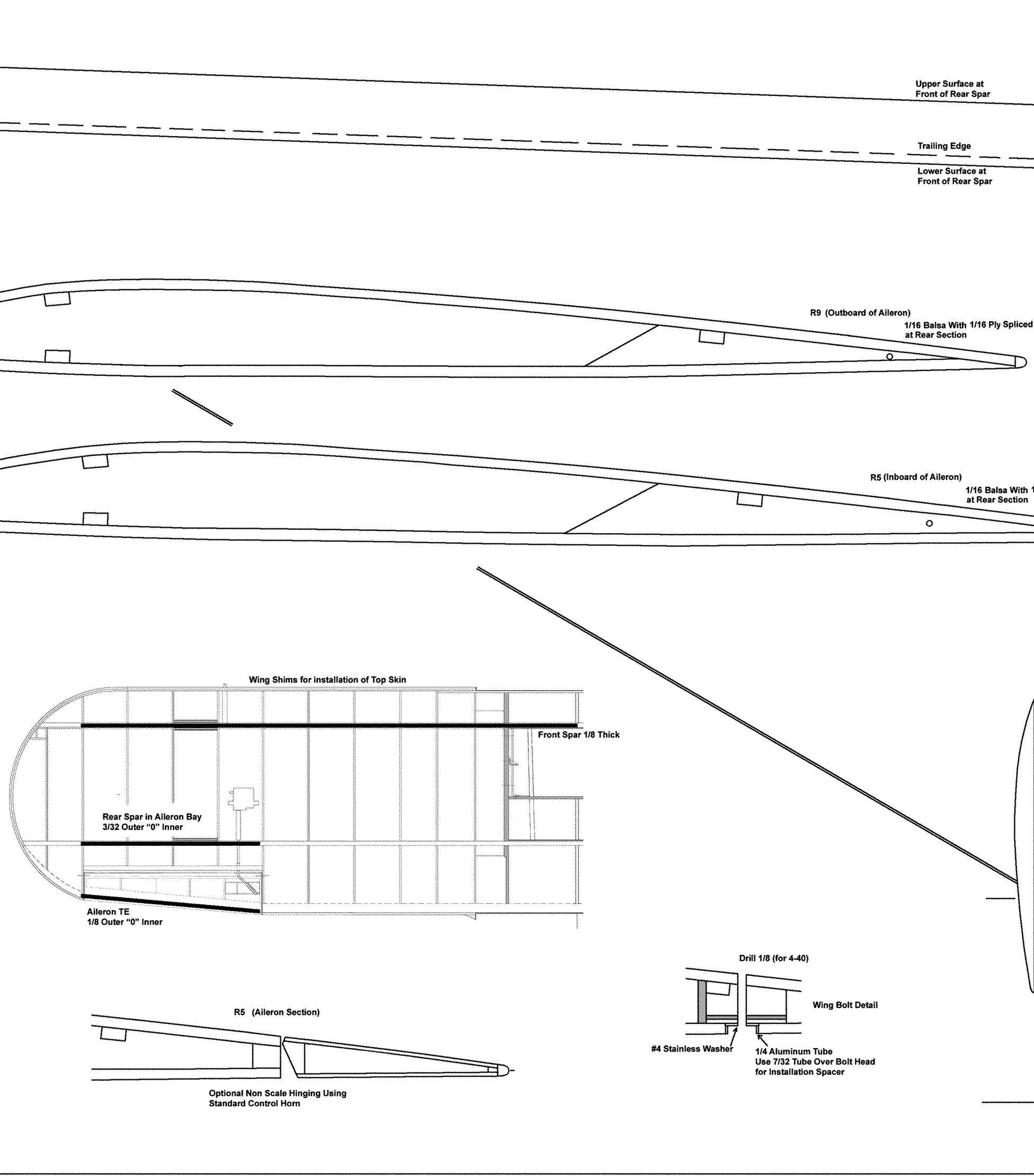
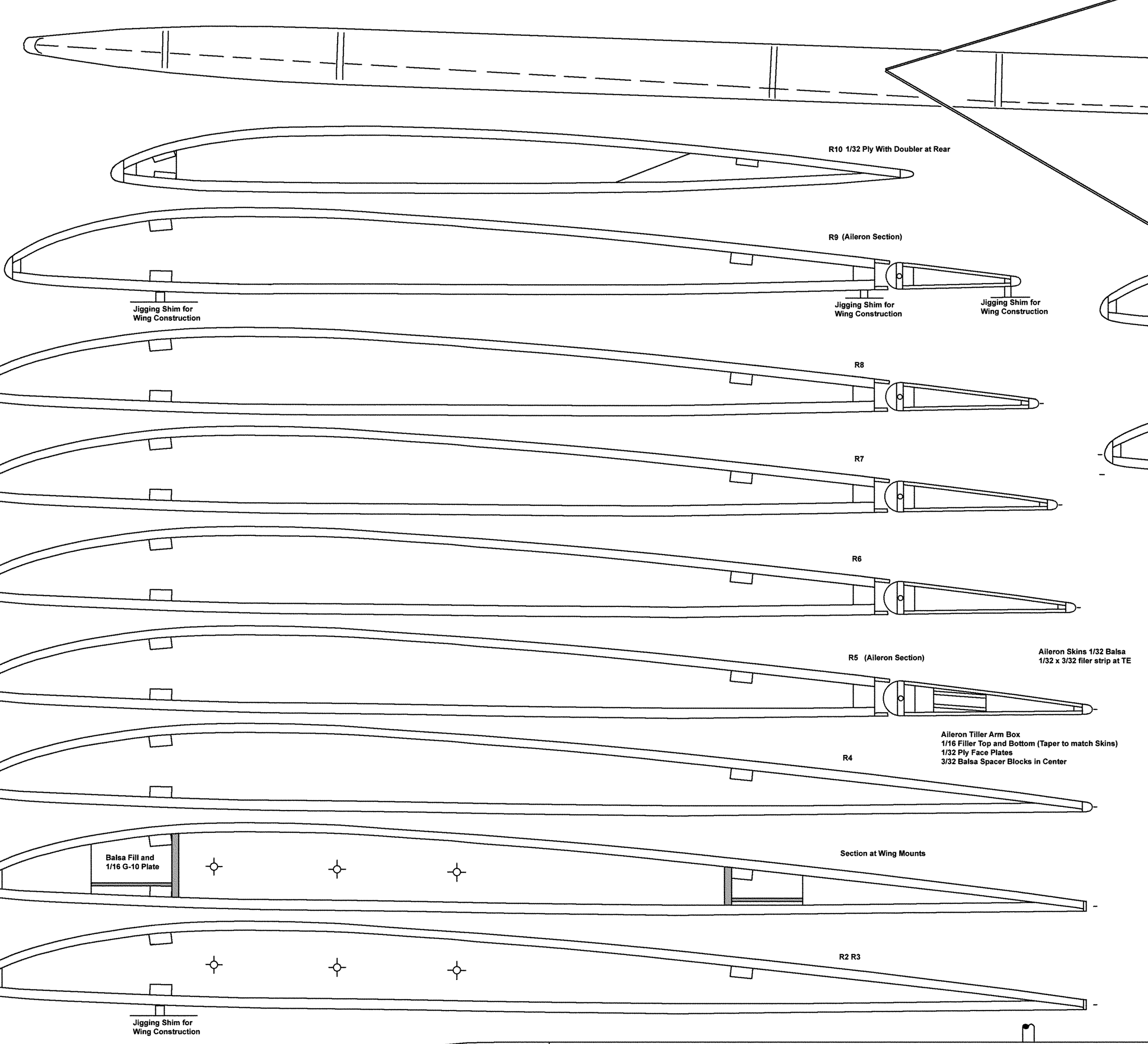
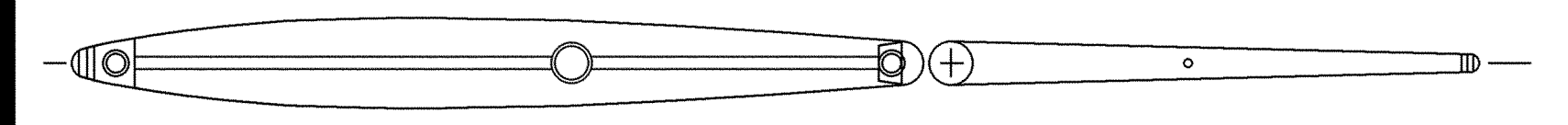

Use 3/16" Flat Steel Wire for Wings Use 1/8" Flat Steel Wire for Tail

Wings and Control Surfaces - Obtain From: WING SUPPLY CO. 12100 S. W. 28th Ave., Suite 100, Davie, FL 33317, USA. Phone: (754) 944-1111. Website: www.wingsupply.com

Wings and Control Surfaces - Obtain From: WING SUPPLY CO. 12100 S. W. 28th Ave., Suite 100, Davie, FL 33317, USA. Phone: (754) 944-1111. Website: www.wingsupply.com

Wings and Control Surfaces - Obtain From: WING SUPPLY CO. 12100 S. W. 28th Ave., Suite 100, Davie, FL 33317, USA. Phone: (754) 944-1111. Website: www.wingsupply.com

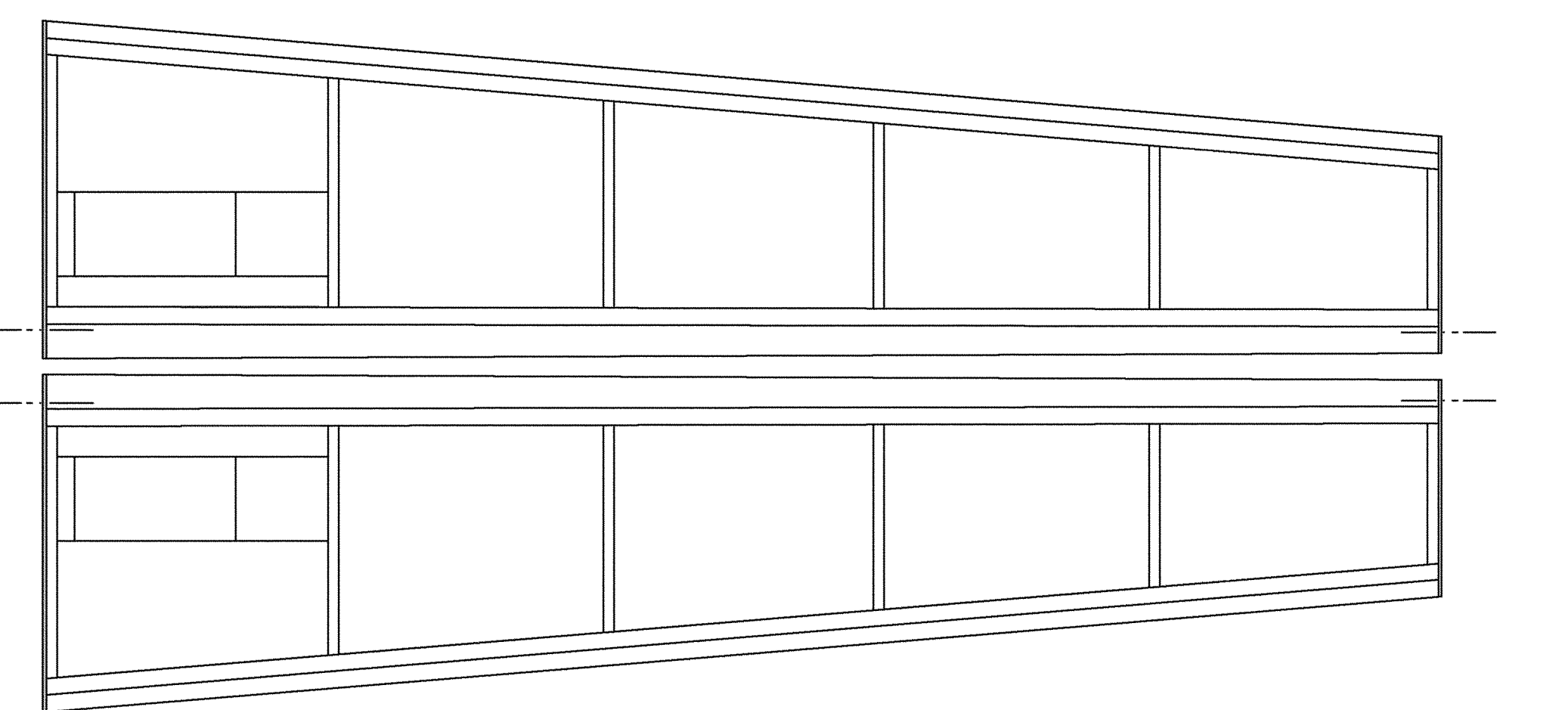
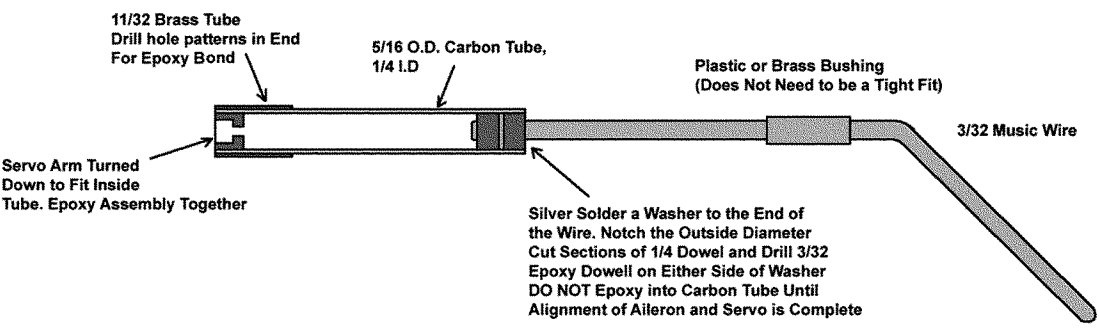

Wedell Williams Model 44
Number 44 1932 / 1933 Version
1/5 Scale 61.6 Span 722 Sq In
Sheet 2 of 4



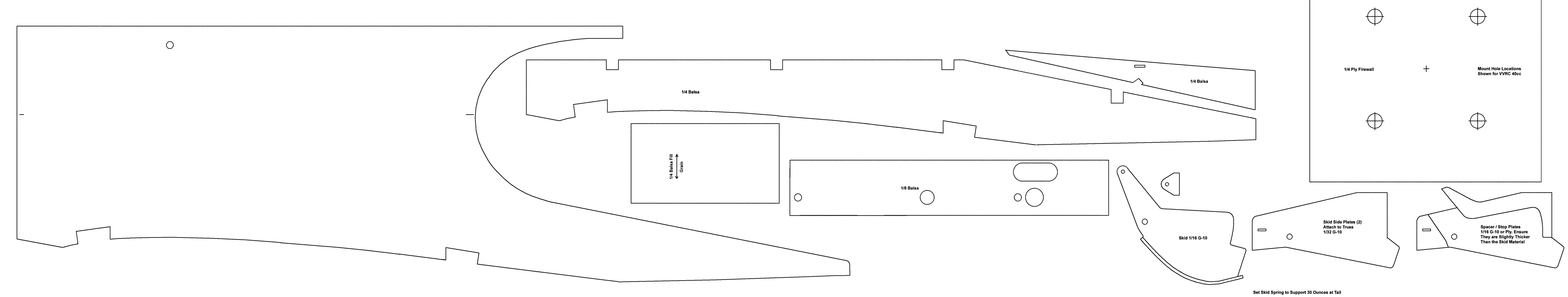
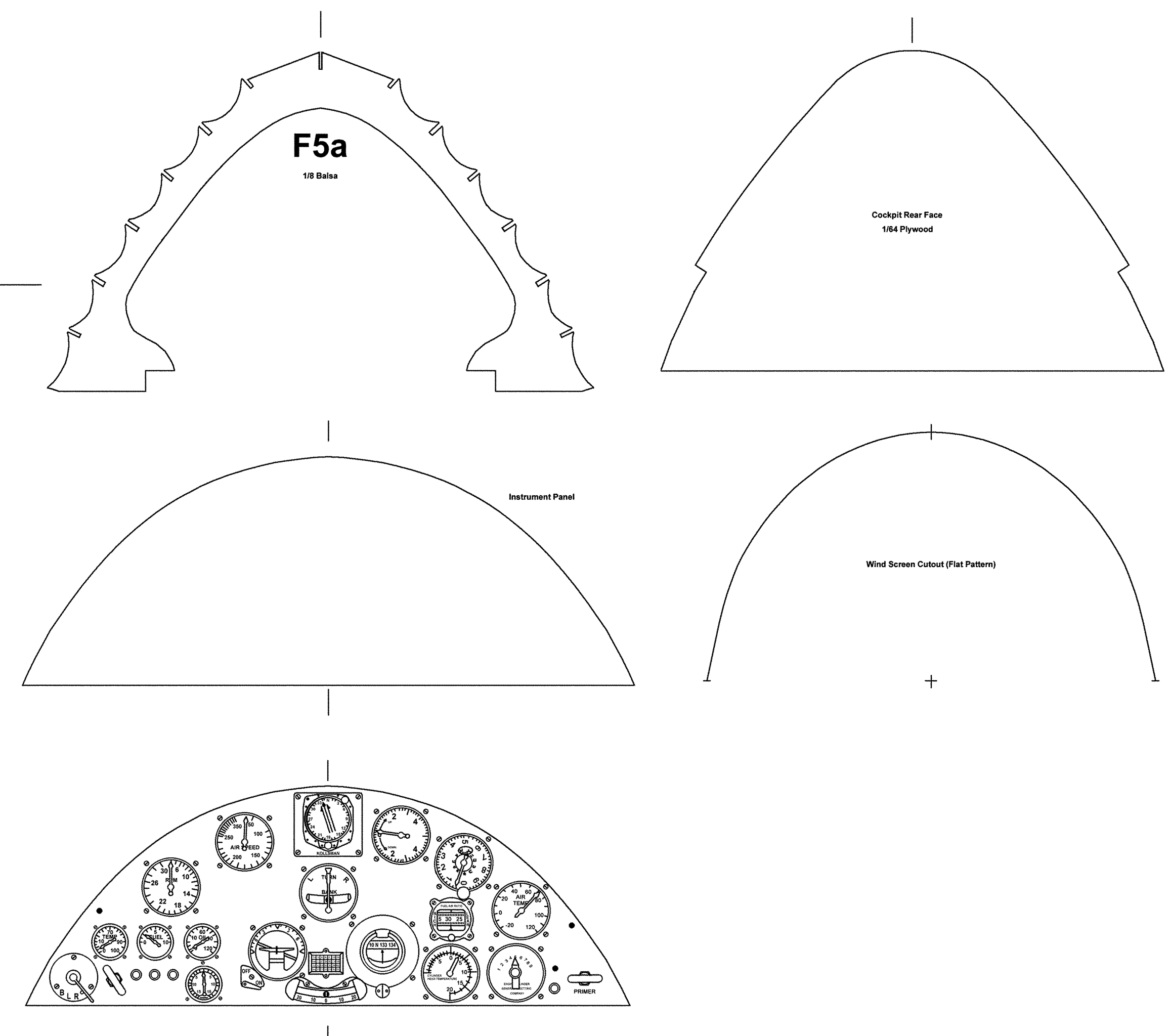
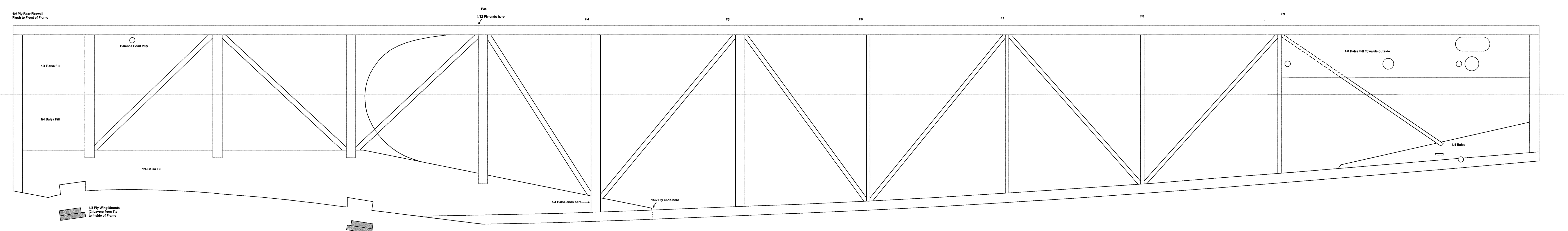
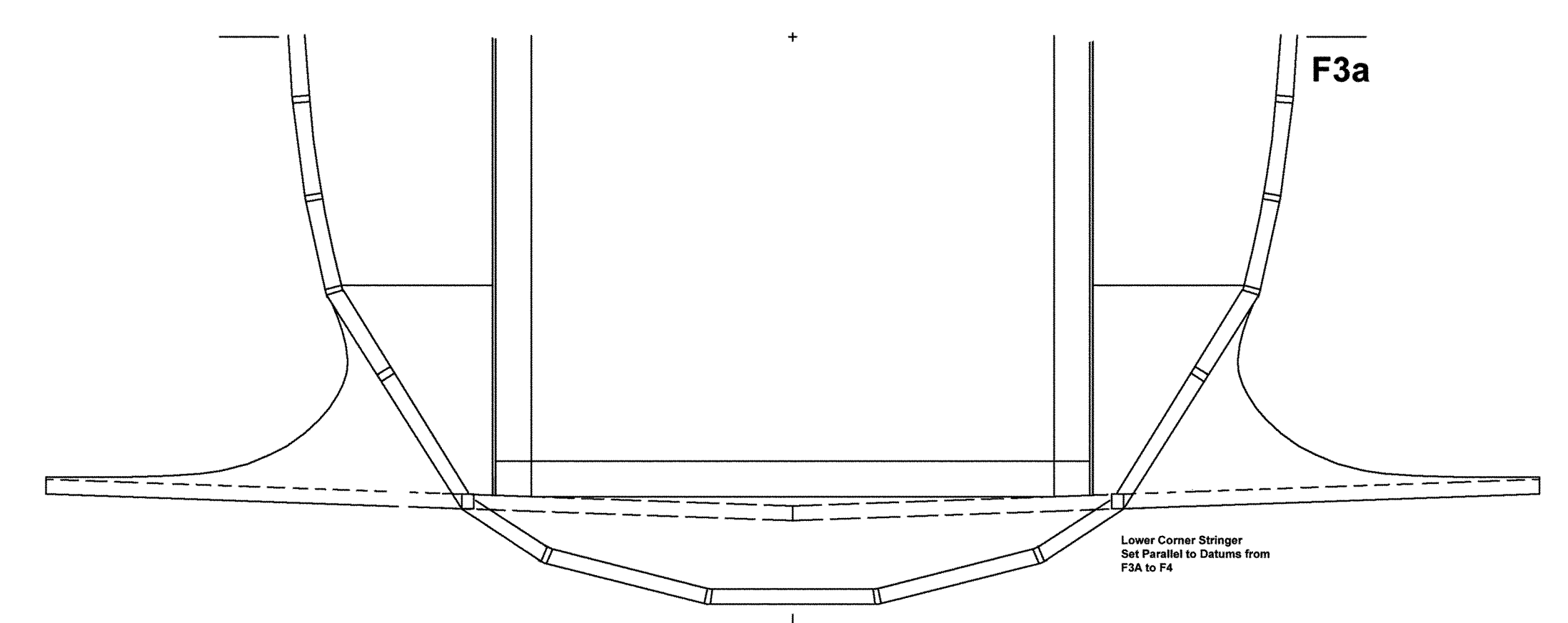
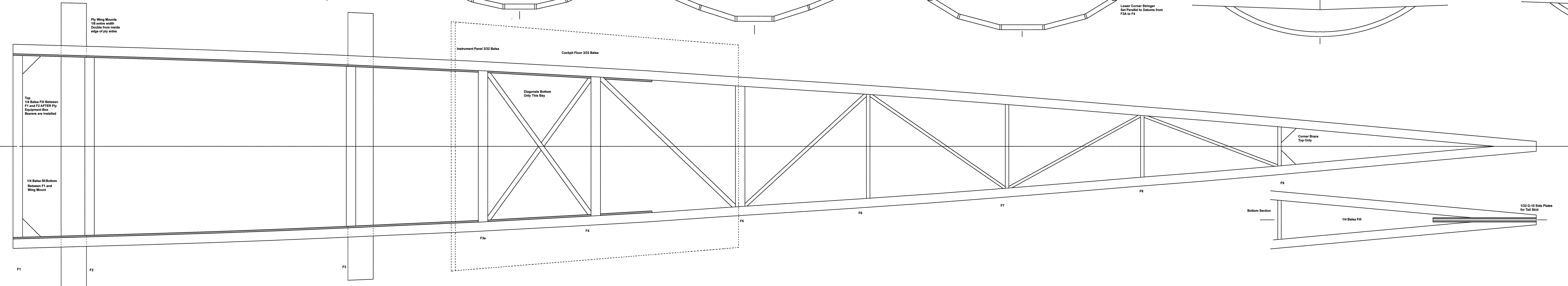
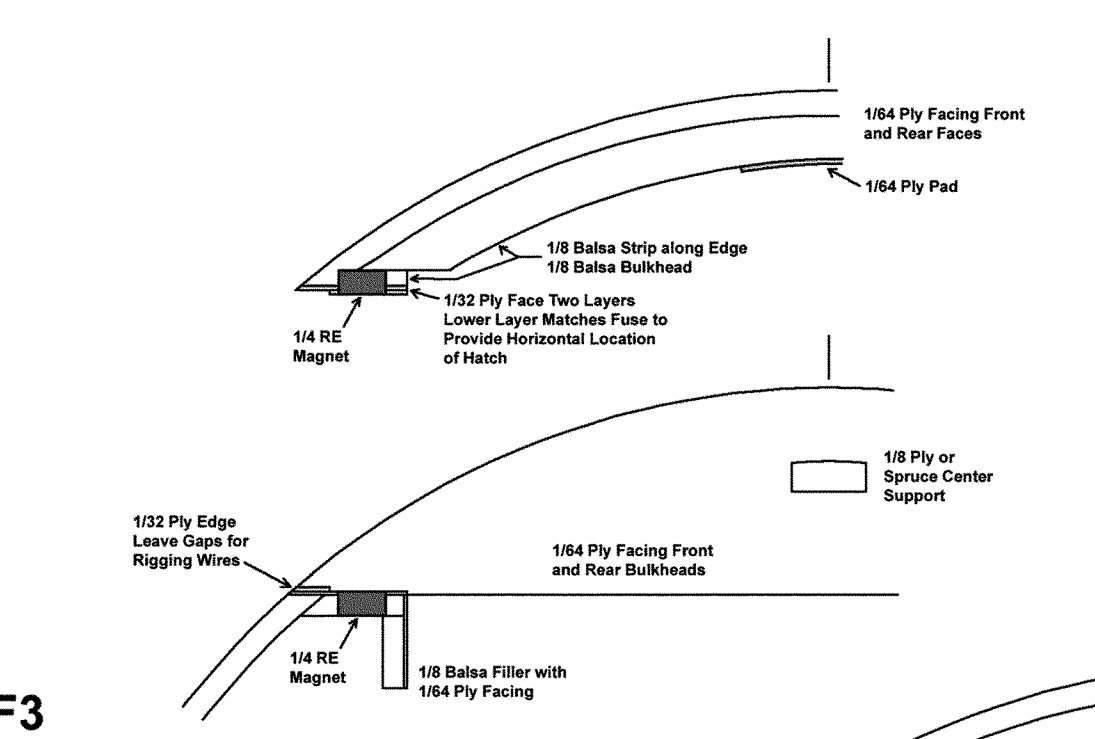


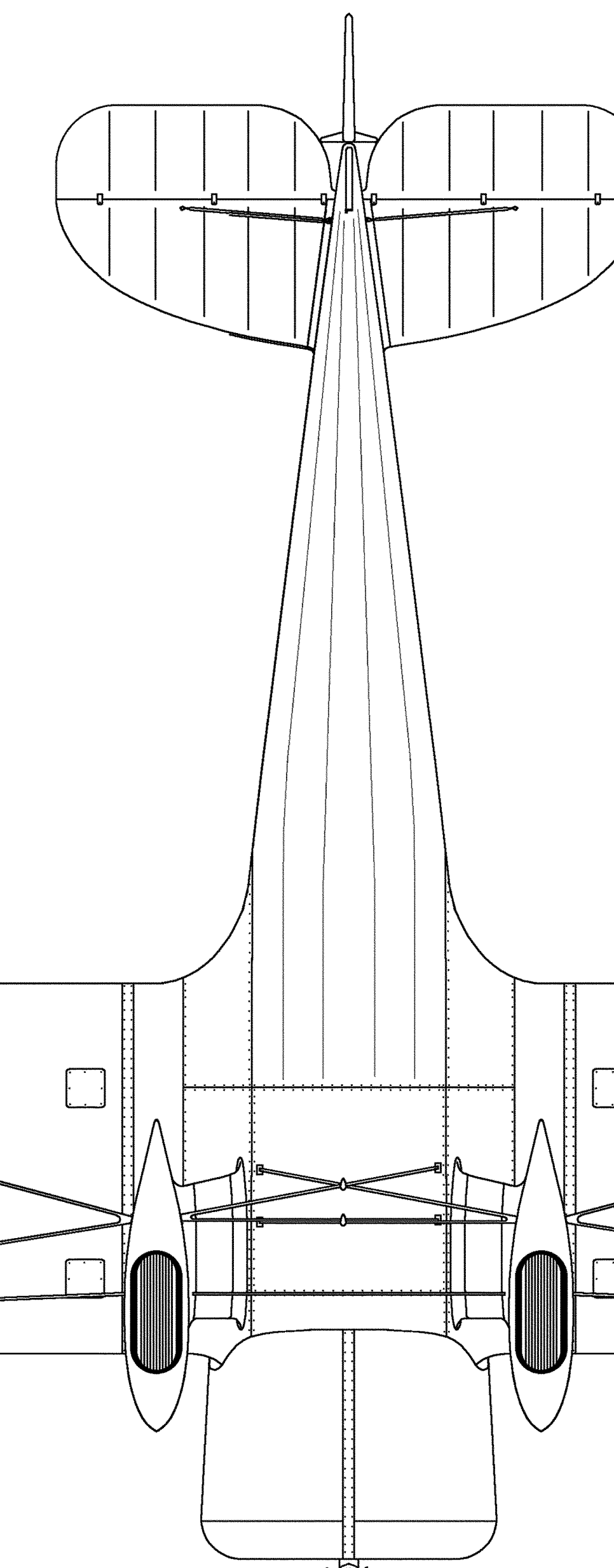
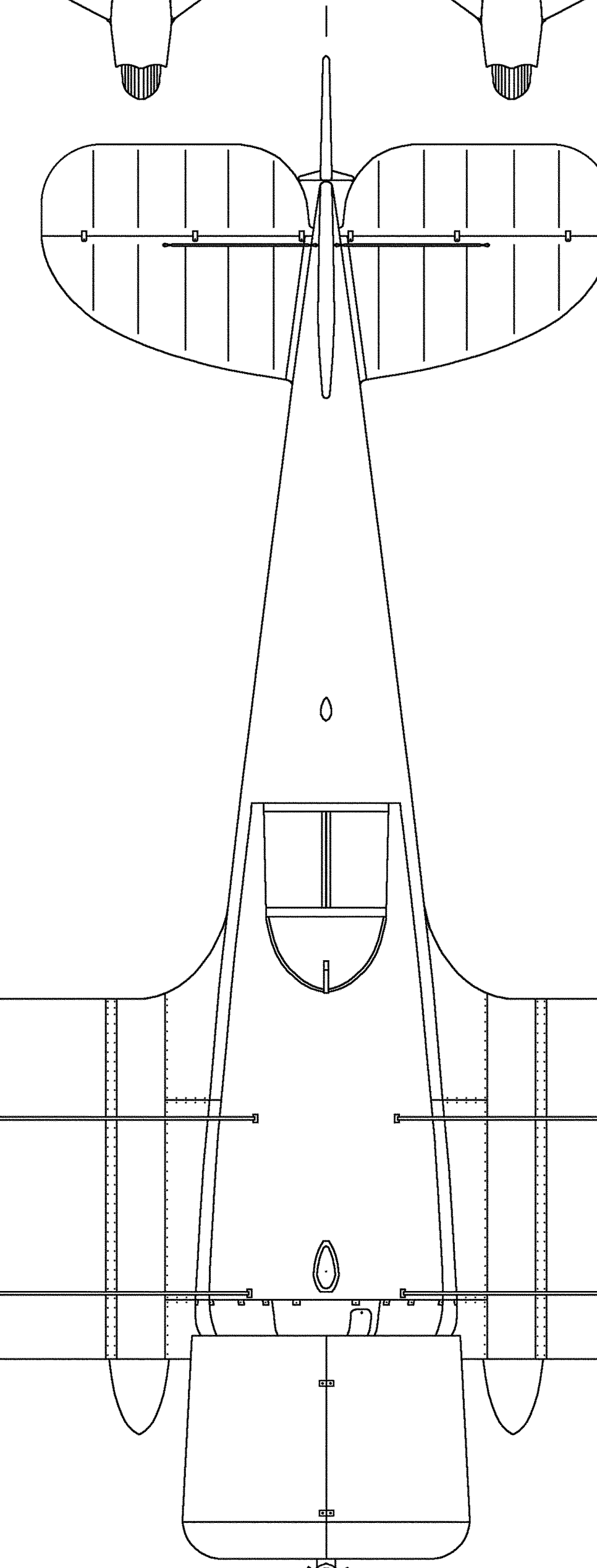
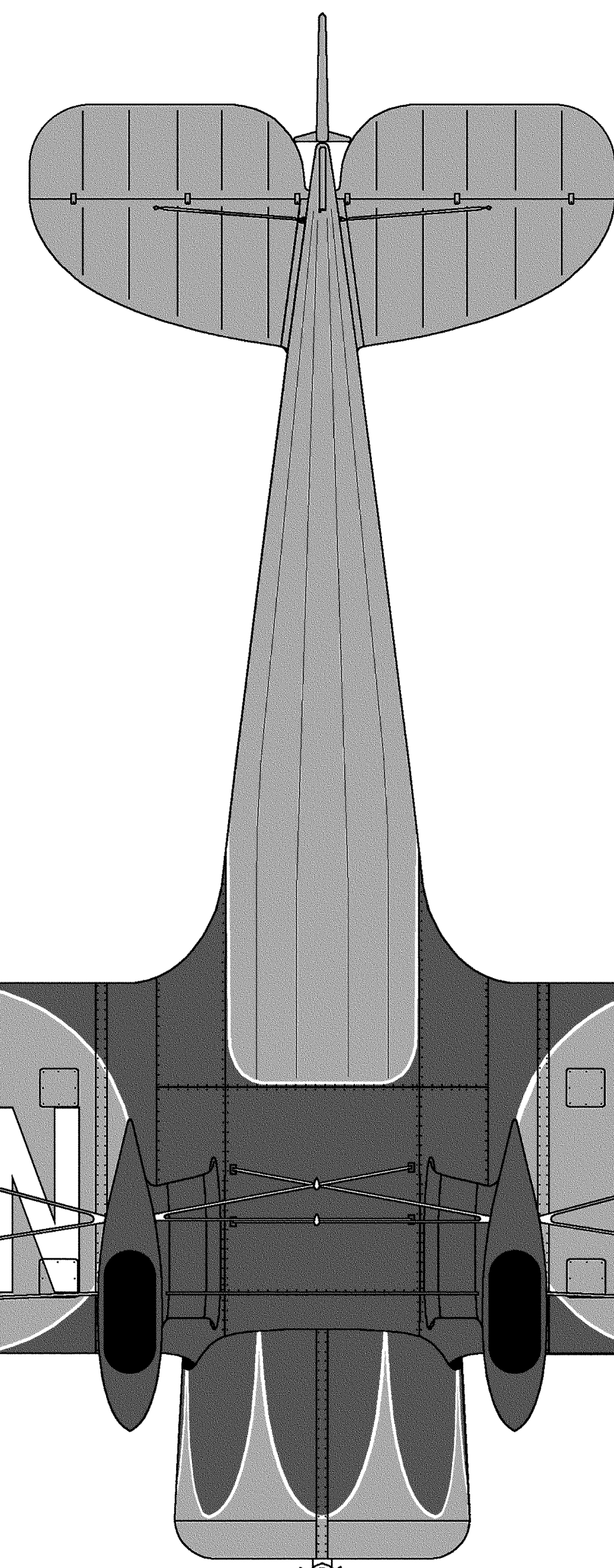
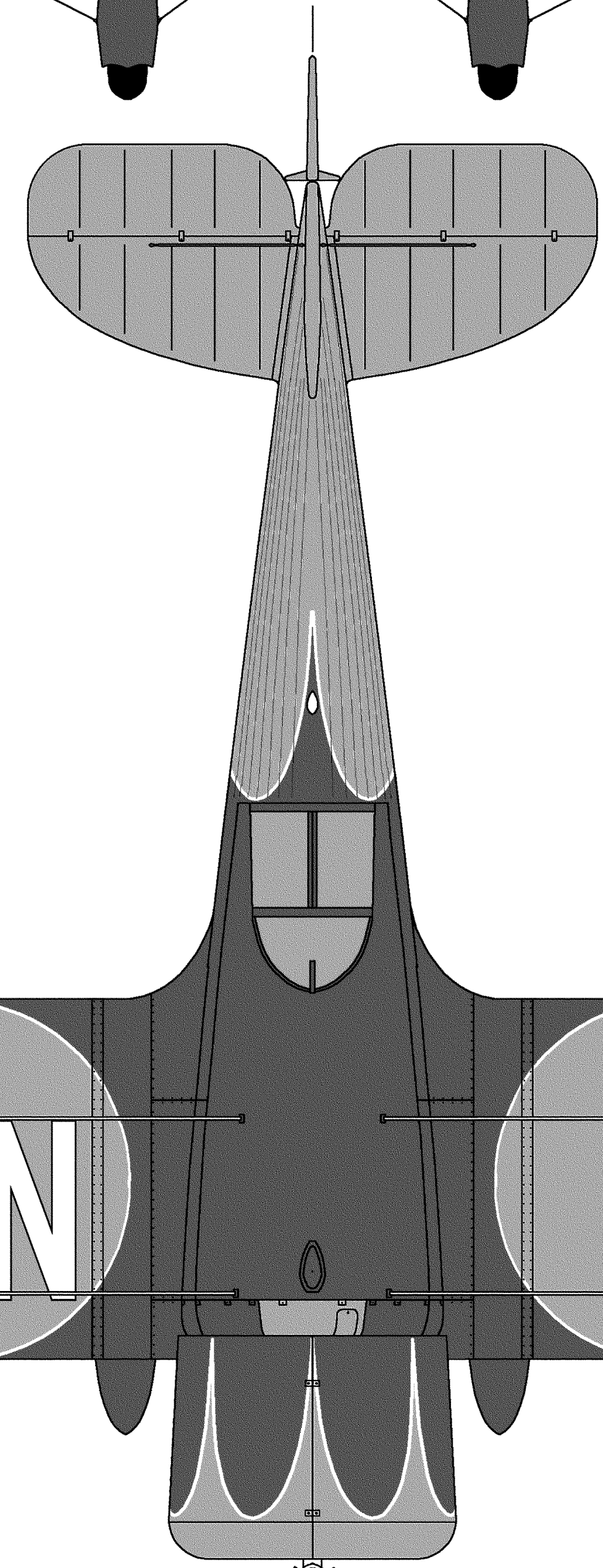
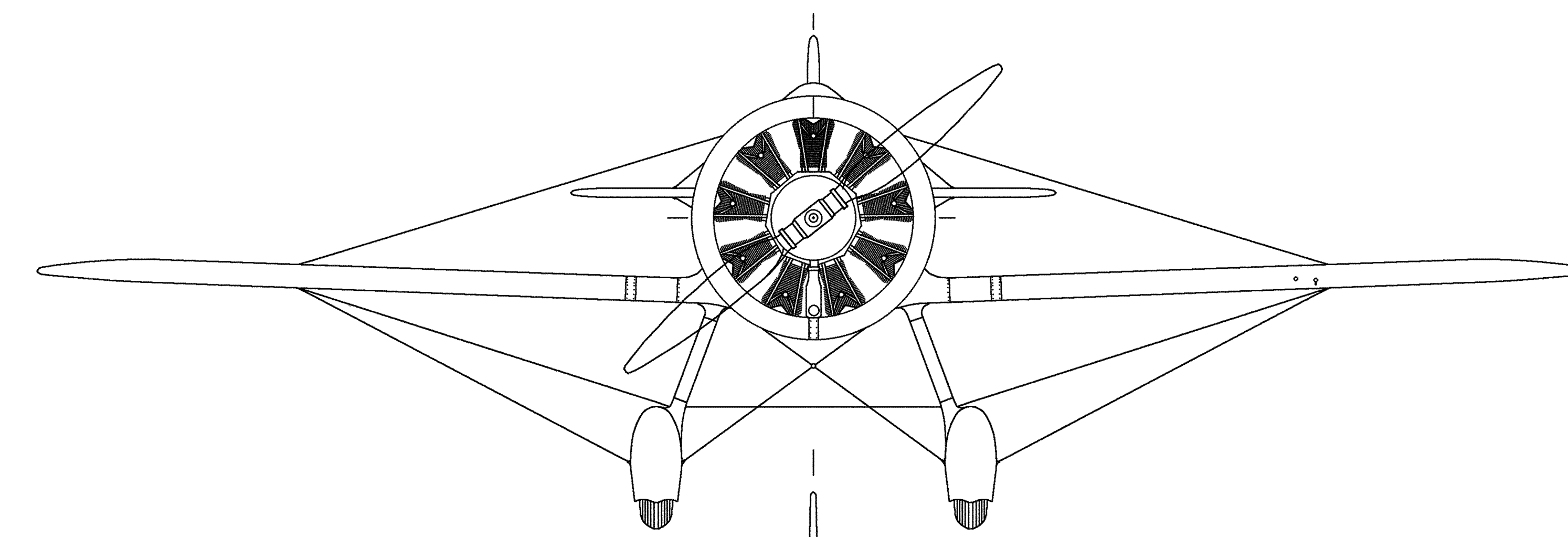
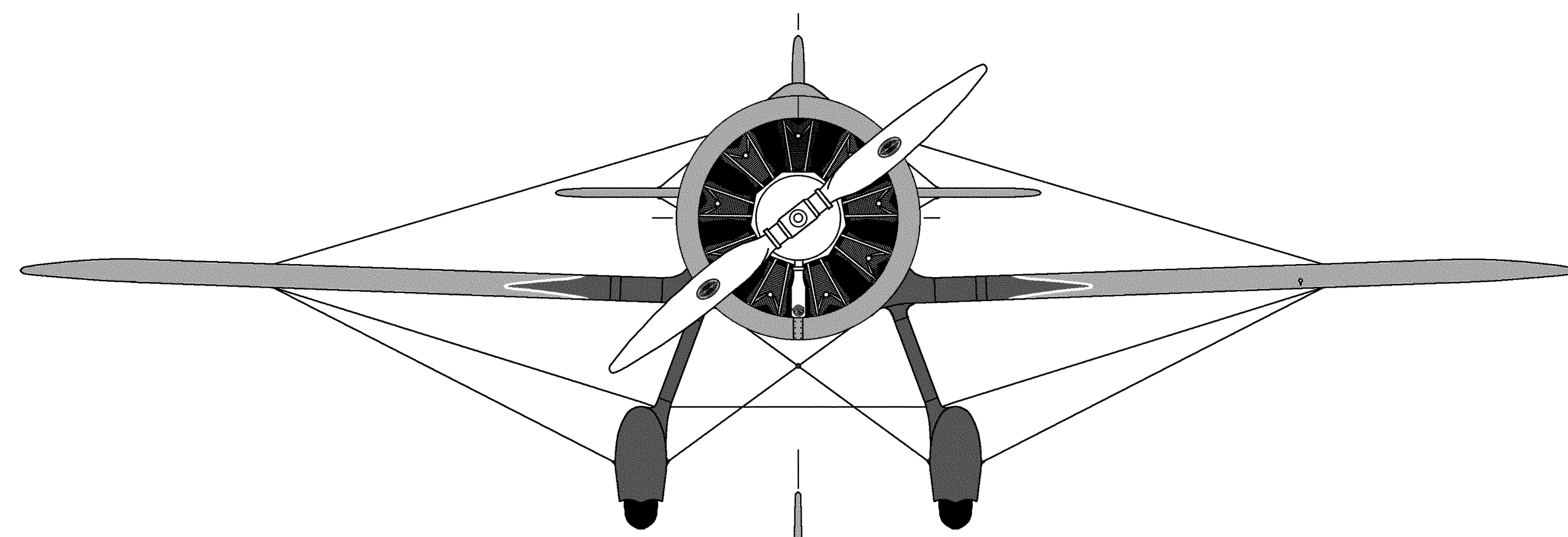

Details are available from:
 Callie Graphics
 PO Box 1541
 Magdalena NM 87825
 www.callie-graphics.com

Color information:
 Airframe Red and Black
 Numbers white with Black borders
 Center of WW shield blue
 Miss Patterson silver
 Pin striping silver

Scale Drawings shown at 1/4 Model size.
 Drawings developed from a combination
 of the following sources:
 Scale drawings included in the Williams Brothers
 1/32 scale plastic model kit.
 Drawings by R. A. Hirsch
 Period photographs

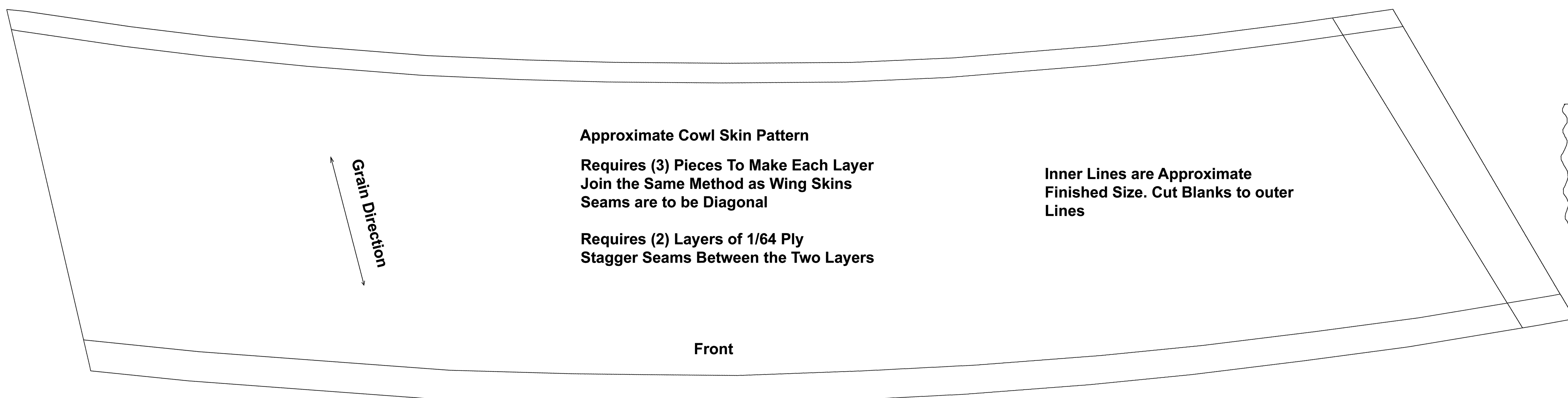
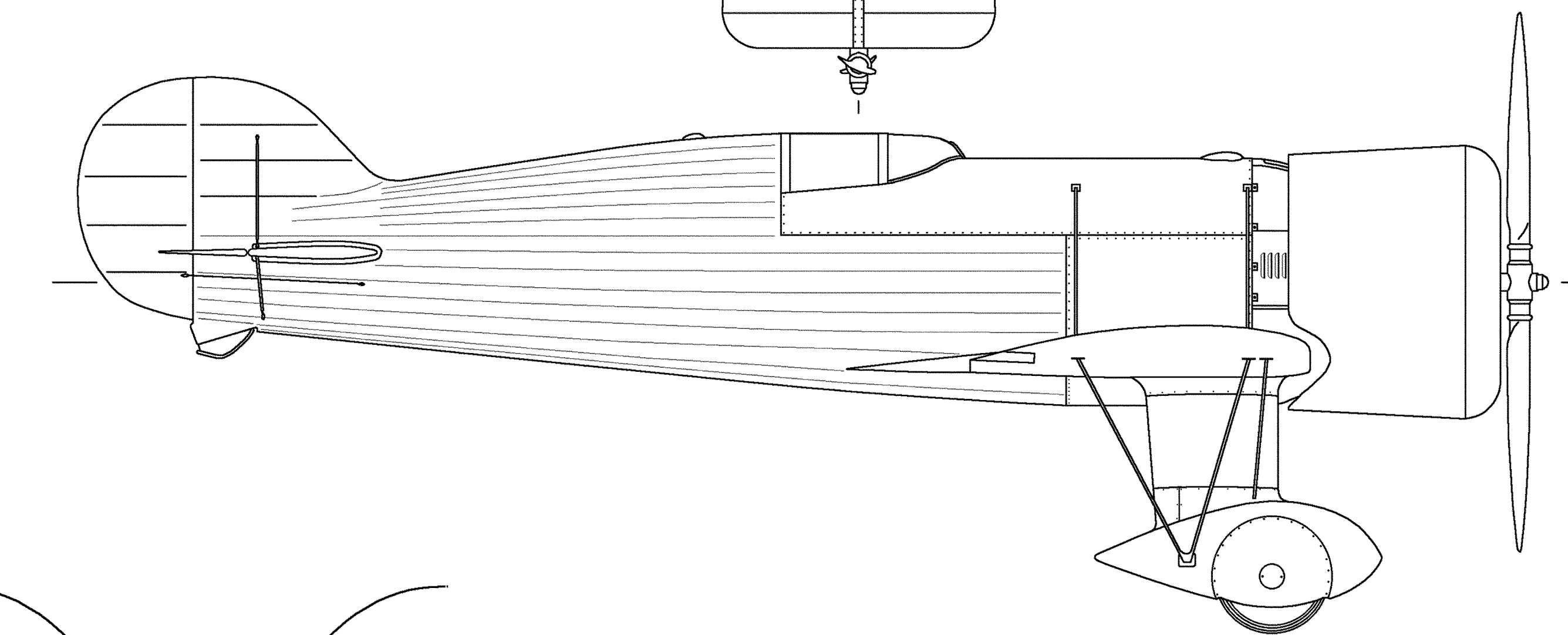
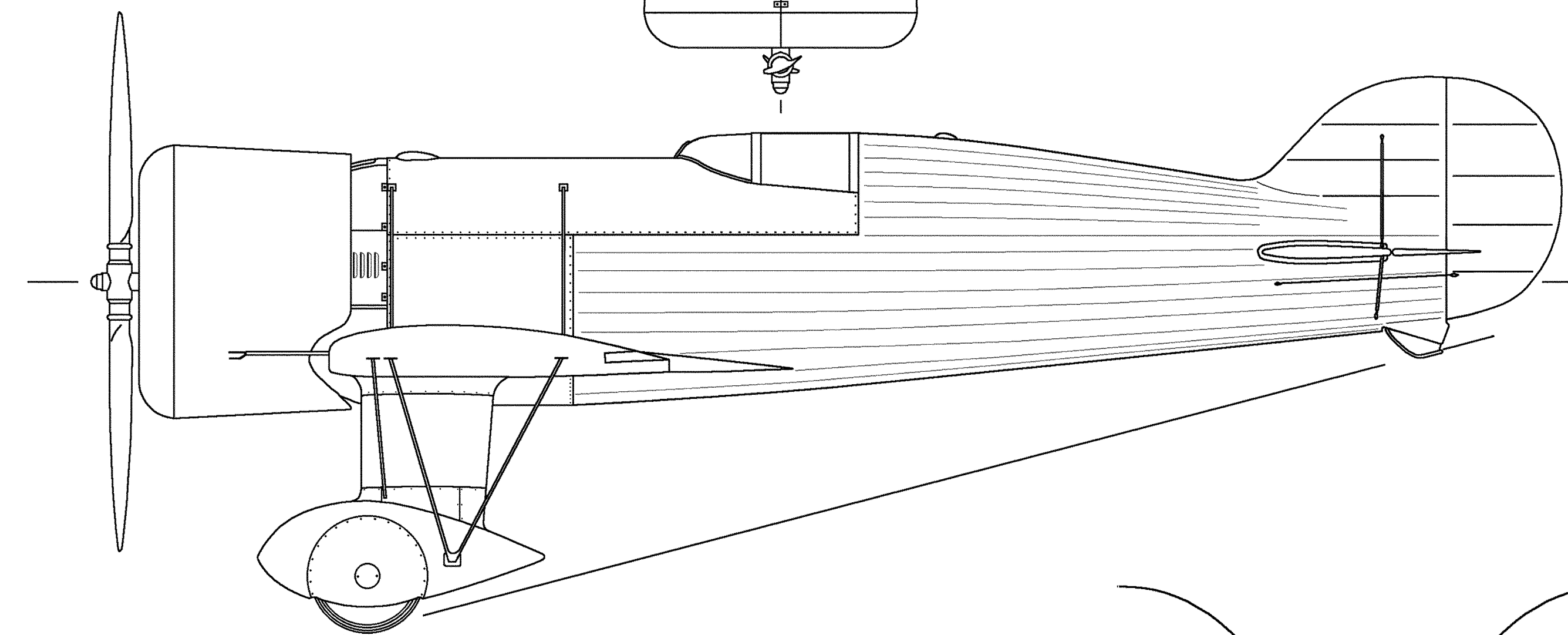
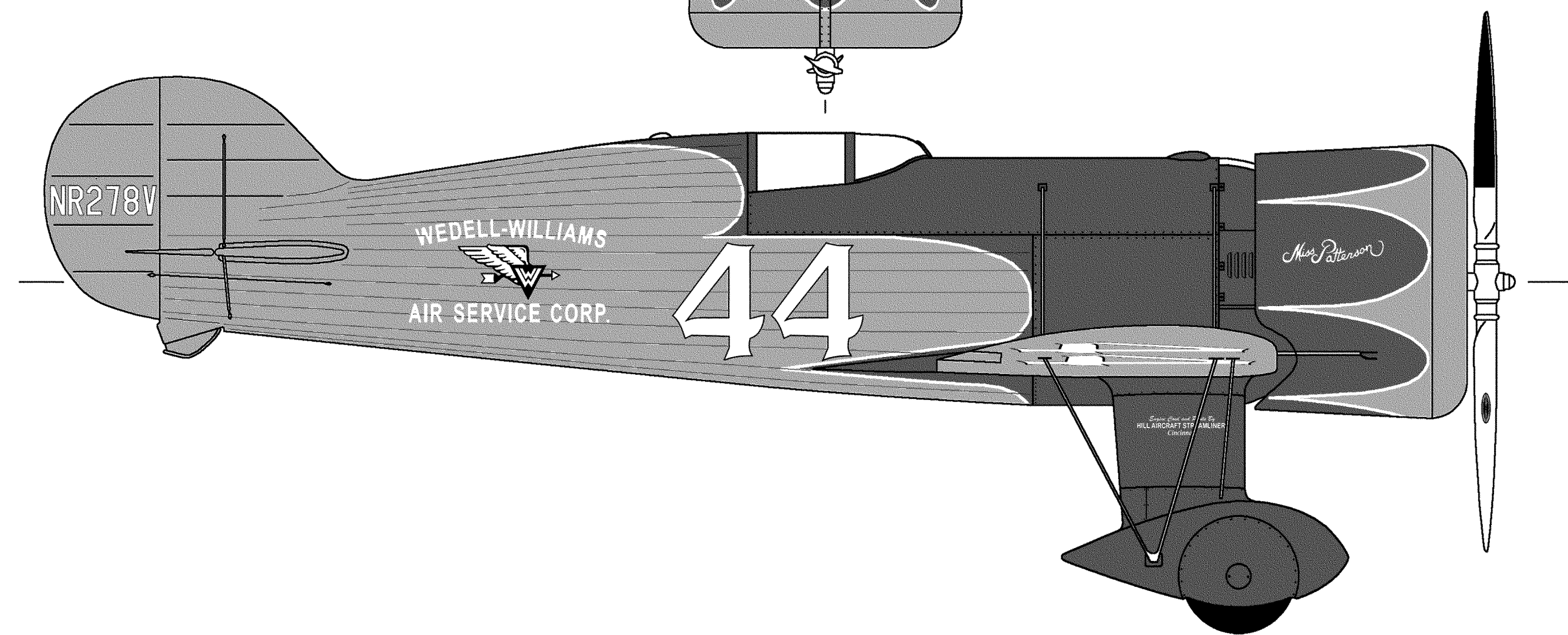
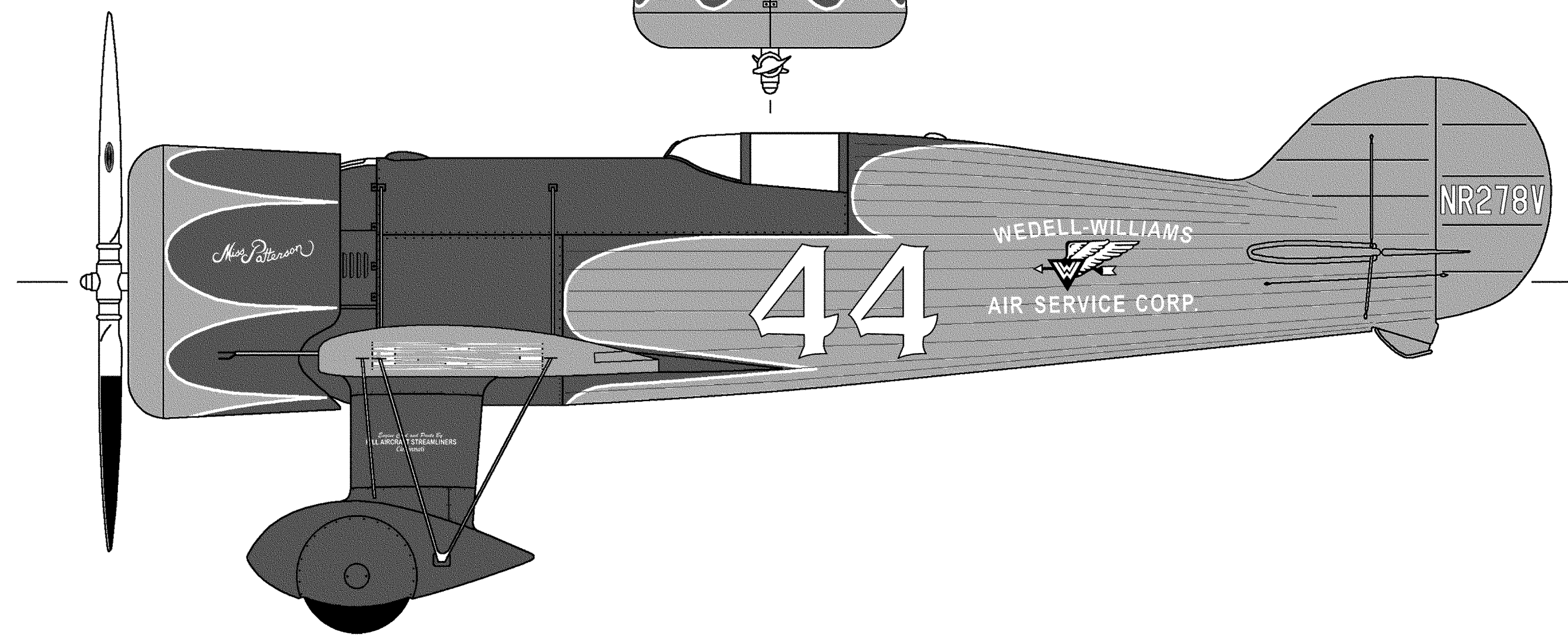
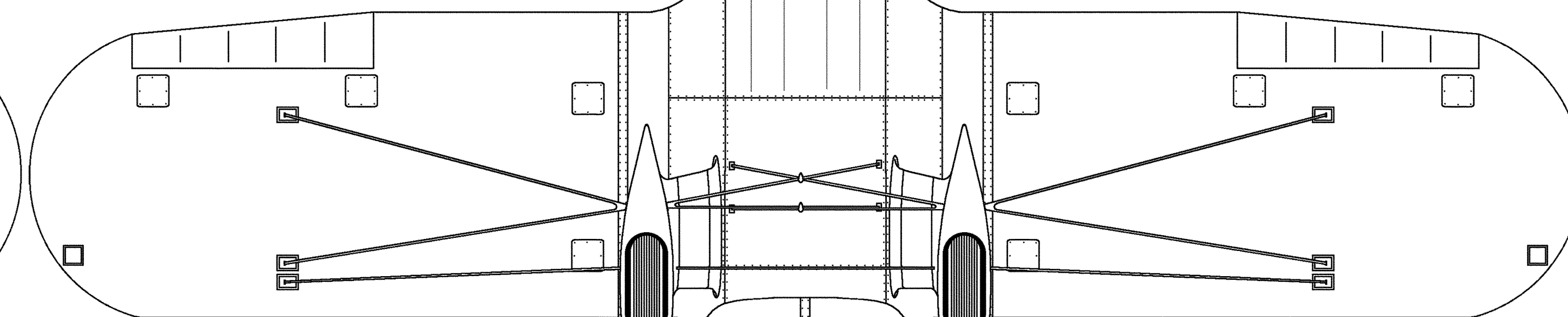
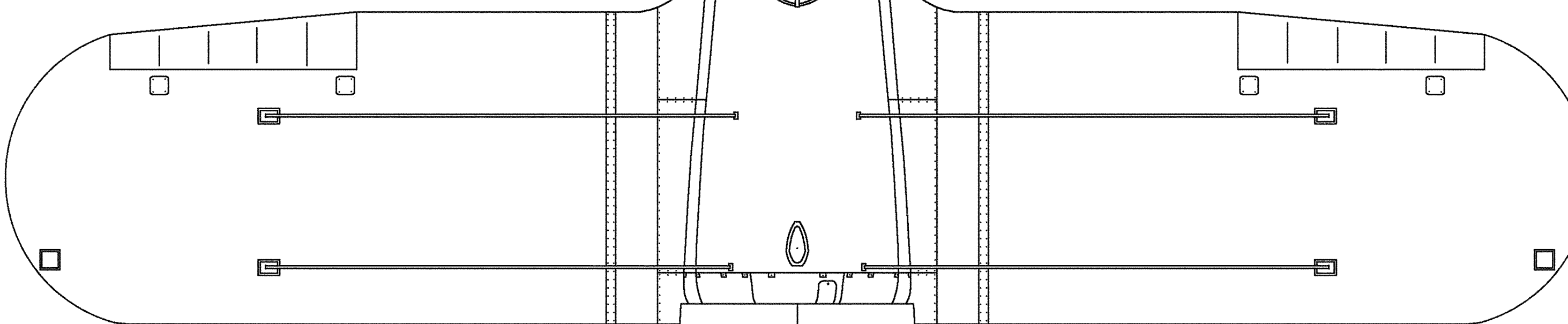
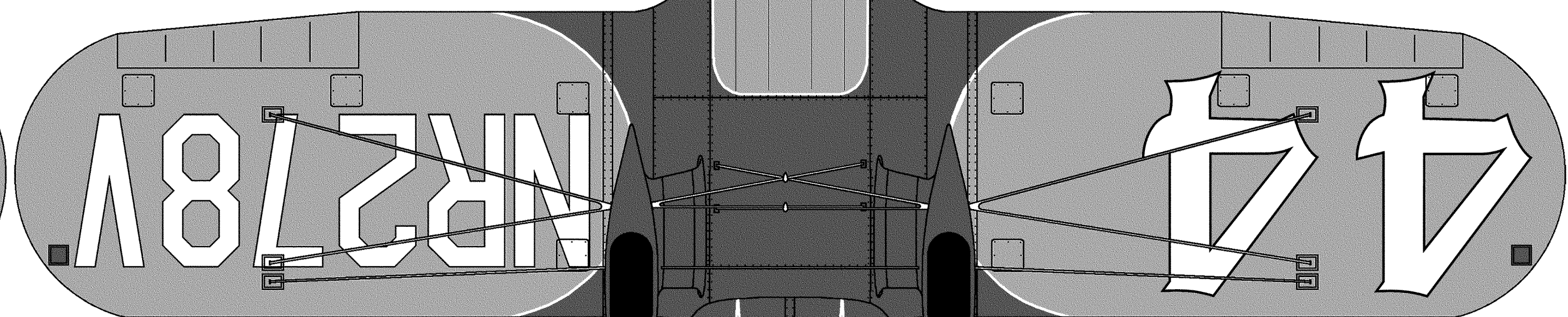
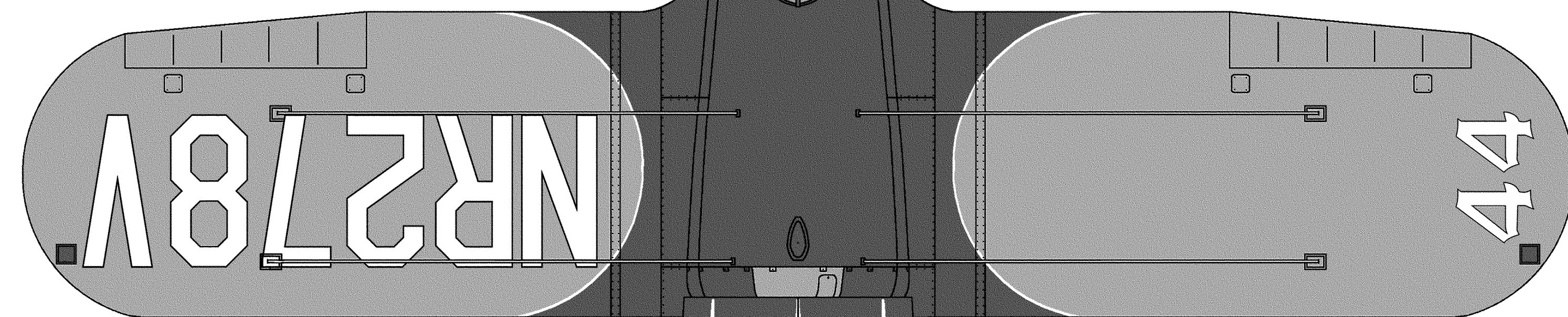

Approximate Cowl Skin Pattern
 Requires (3) Pieces To Make Each Layer
 Join the Same Method as Wing Skins
 Seams are to be Diagonal
 Requires (2) Layers of 1/64 Ply
 Stagger Seams Between the Two Layers

Inner Lines are Approximate
 Finished Size. Cut Blanks to outer
 Lines

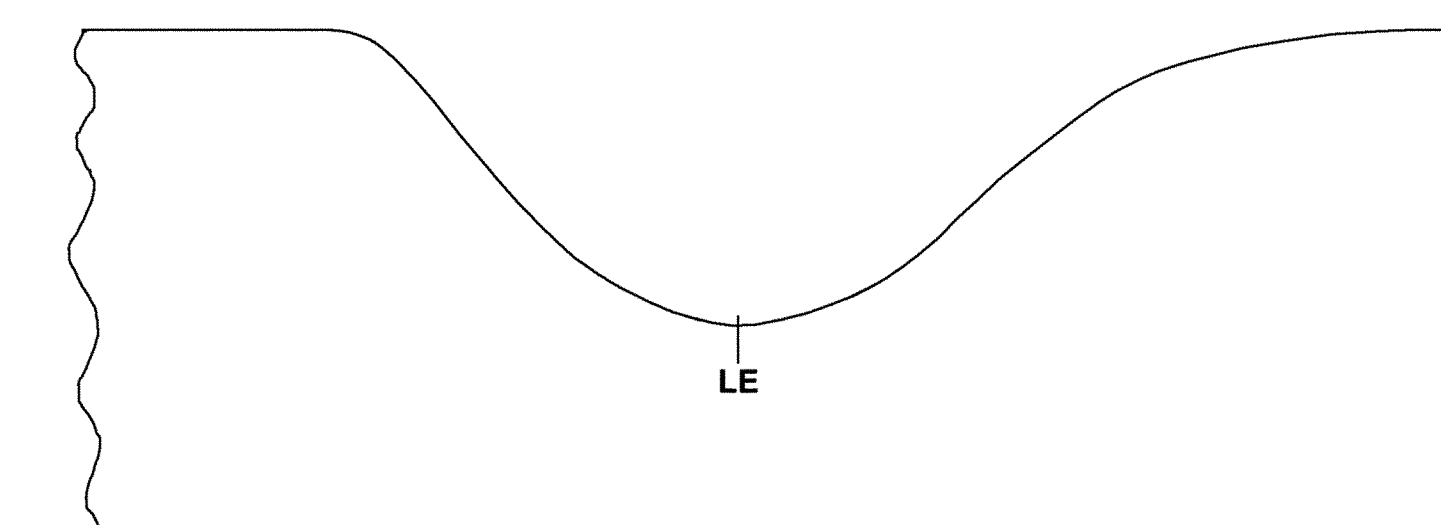

Cowl cutout at wing LE's

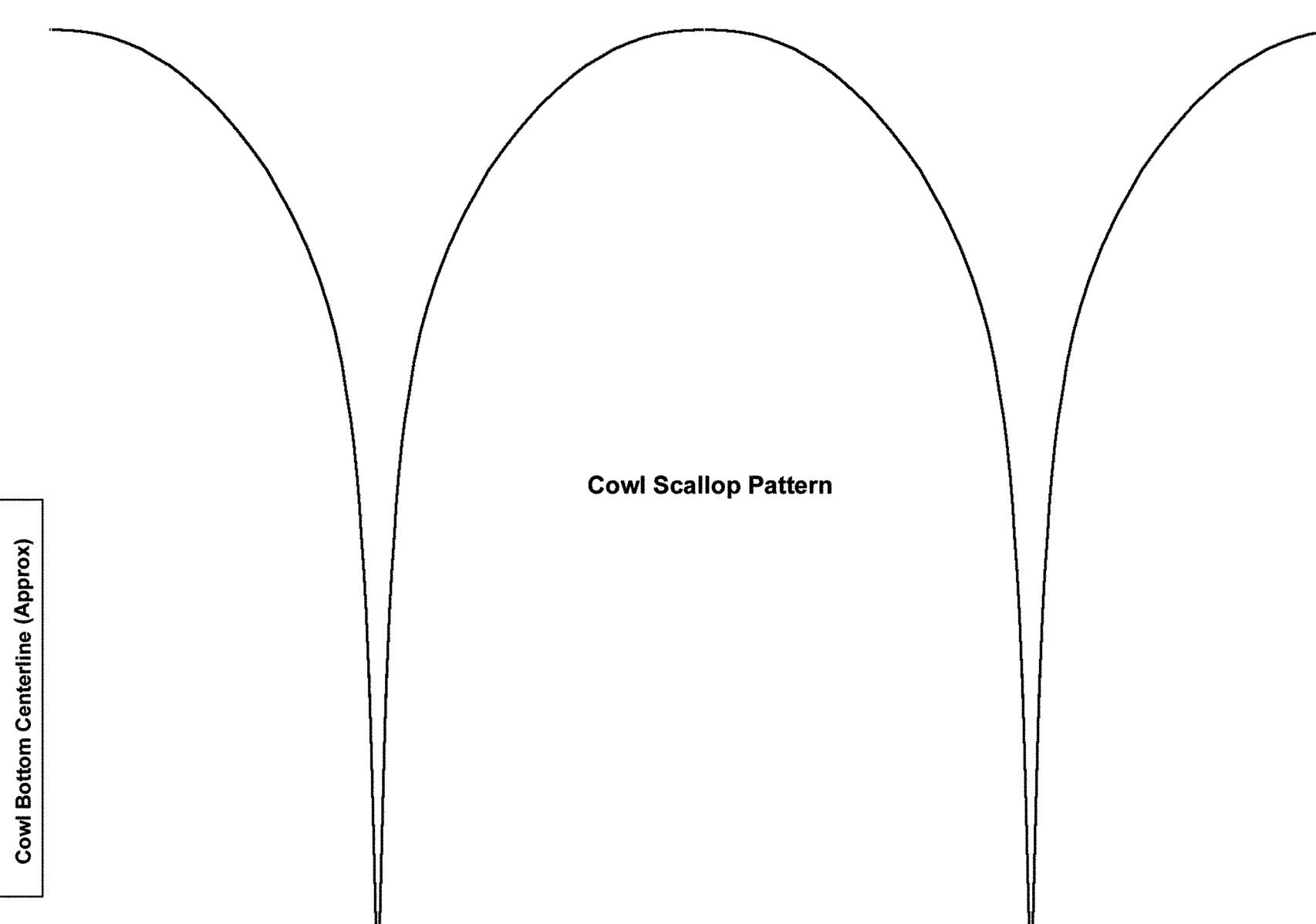

Cowl Scallop Pattern