

66 FLÜGEL-DRAUFSICHT, M 1:2  
(ohne Abschlusspanz (40) und Verkleidung (41) dargestellt)

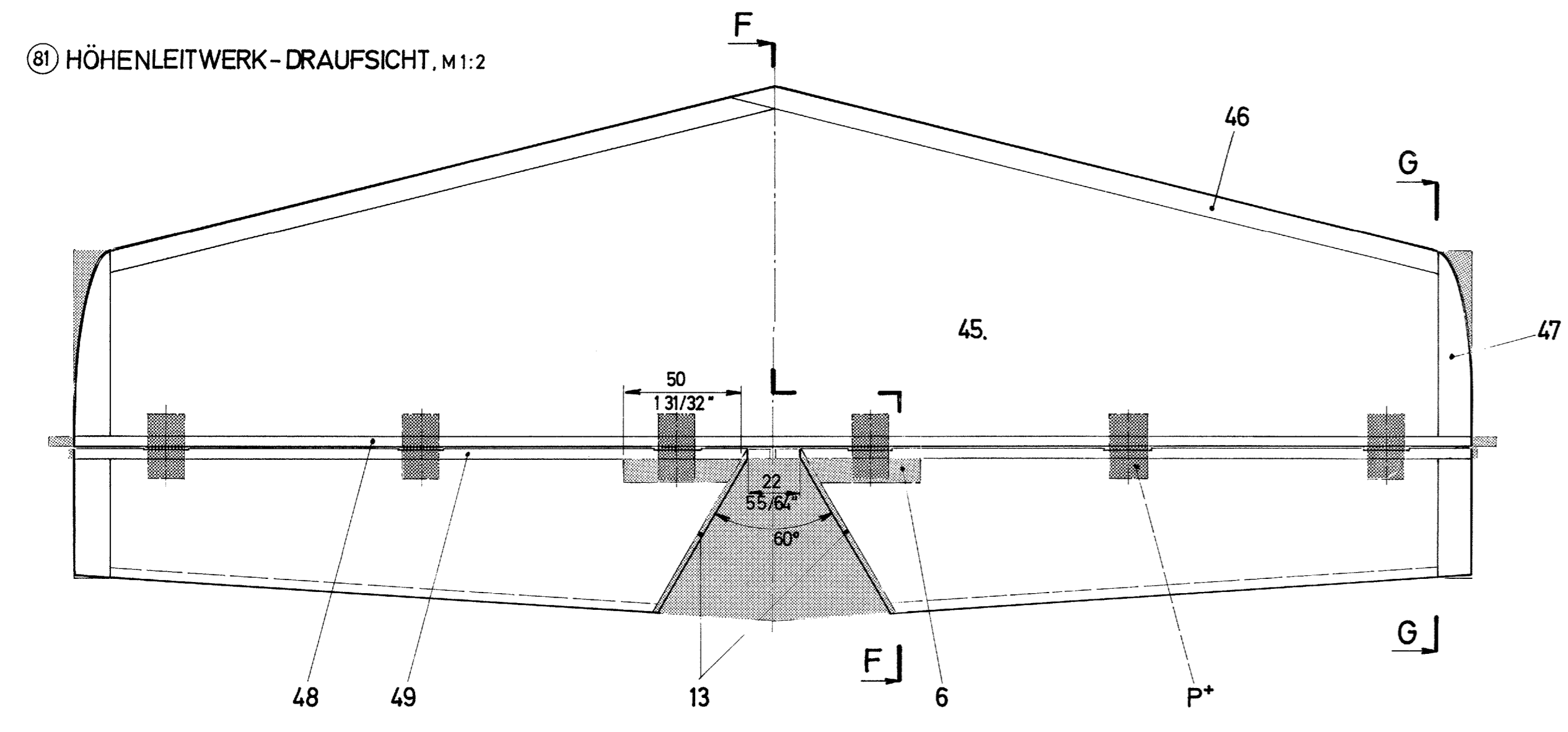
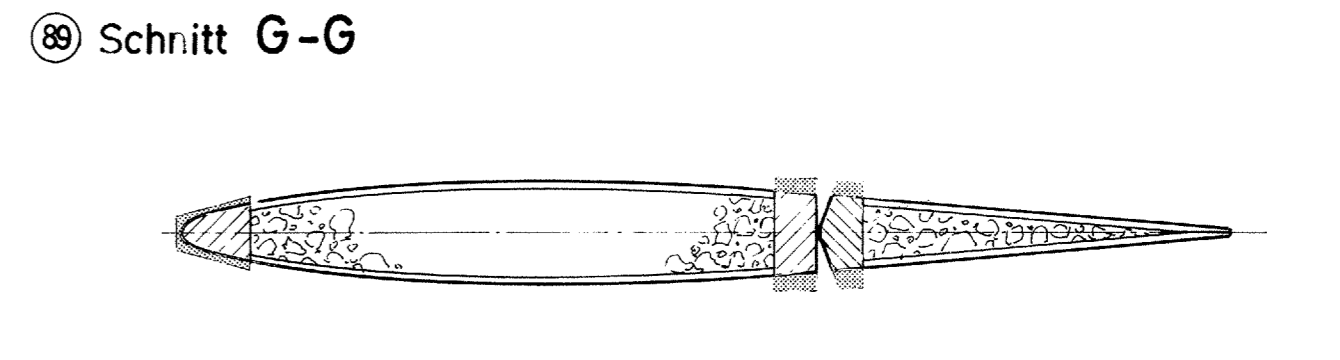
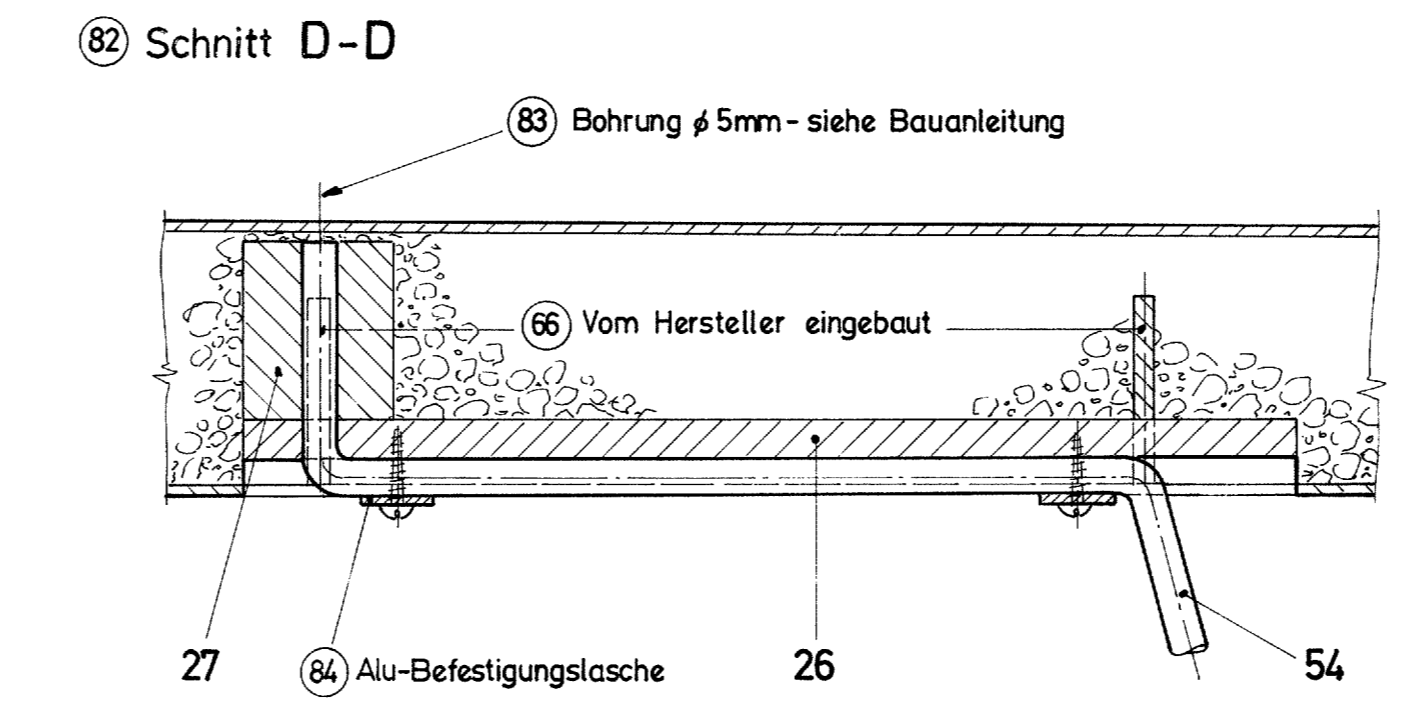
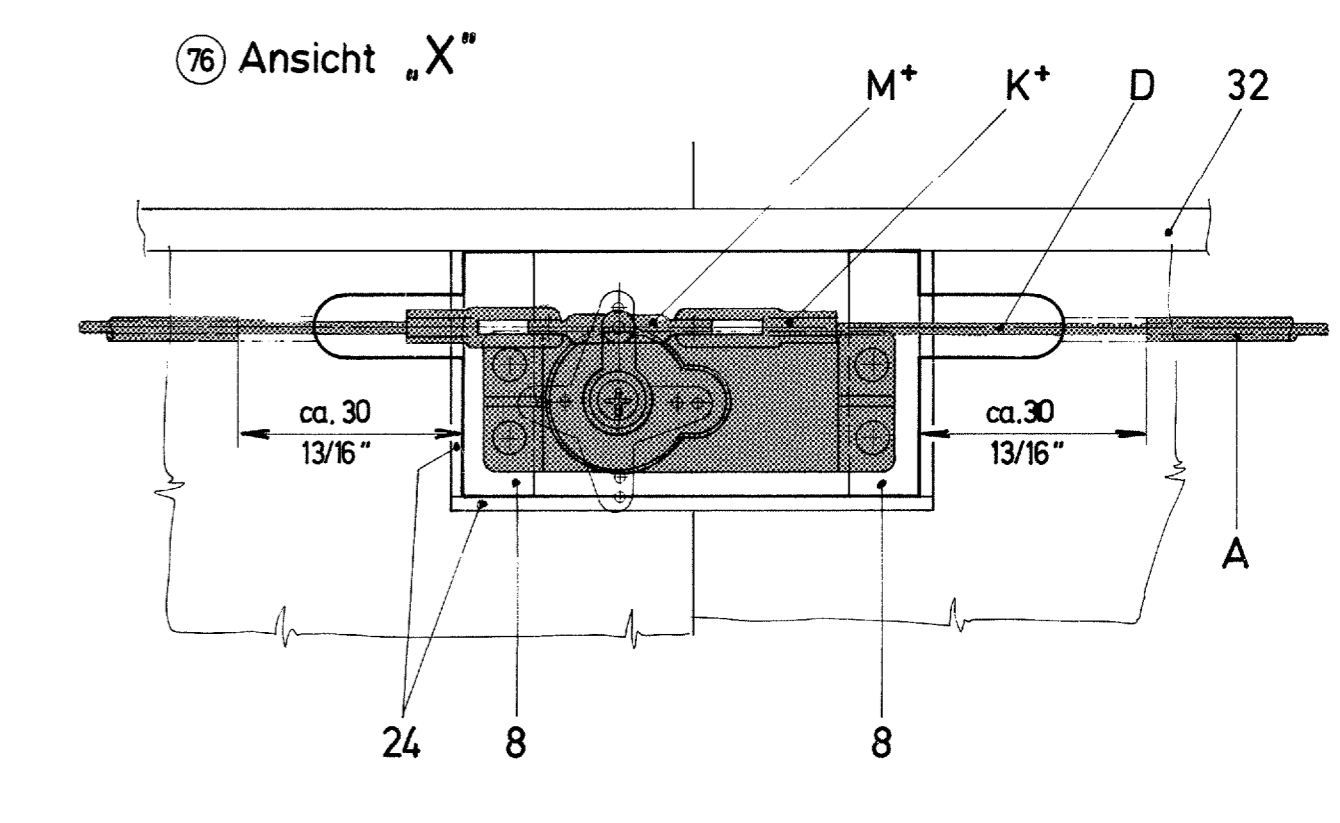
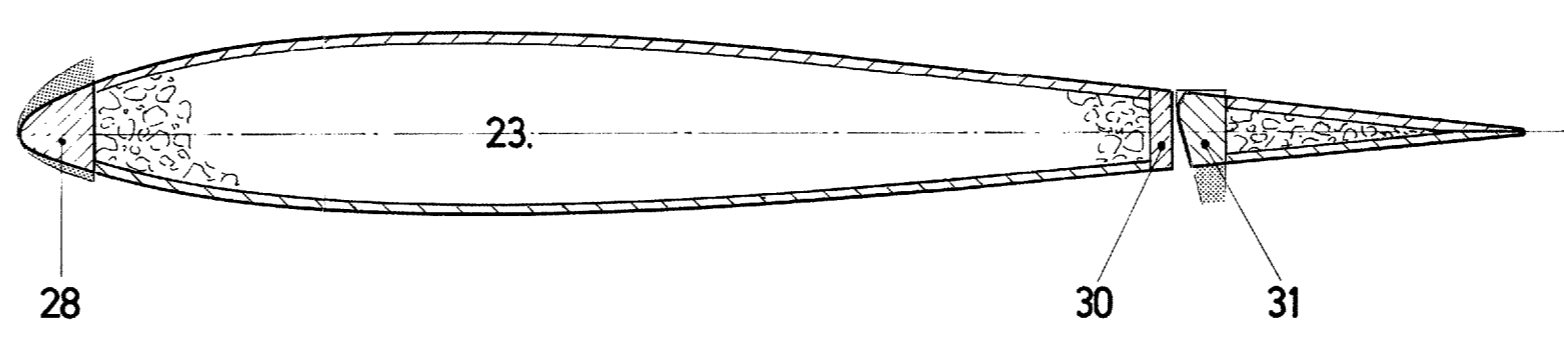
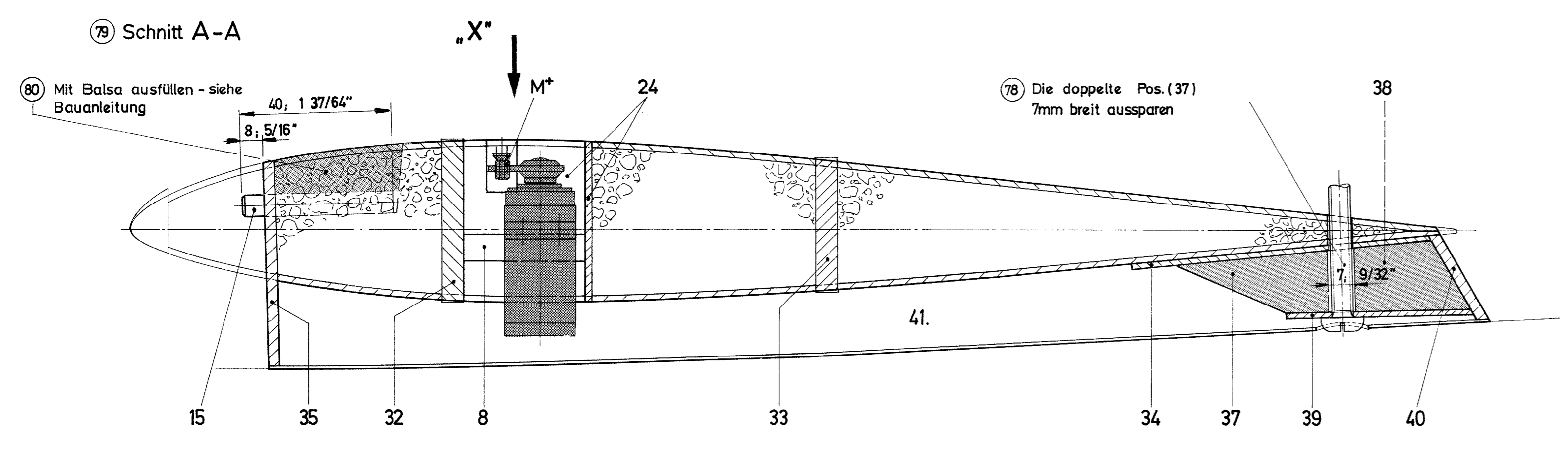
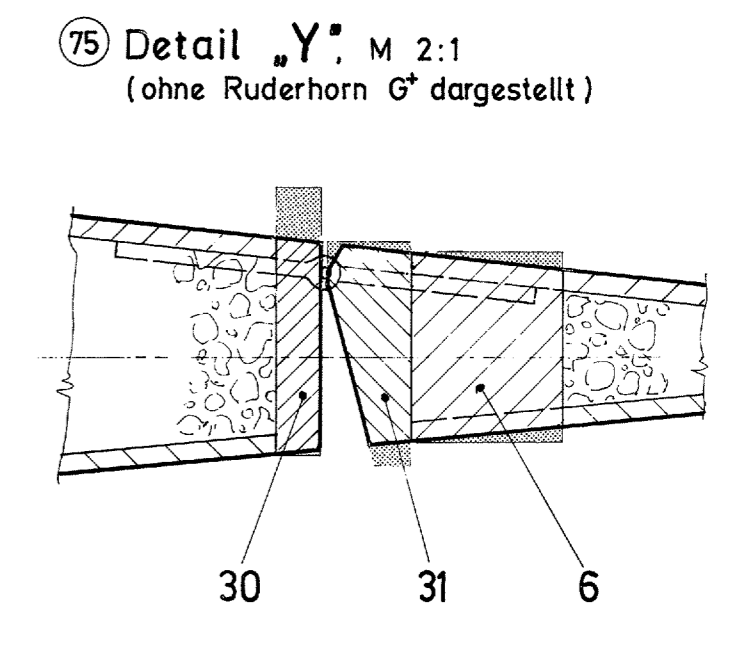
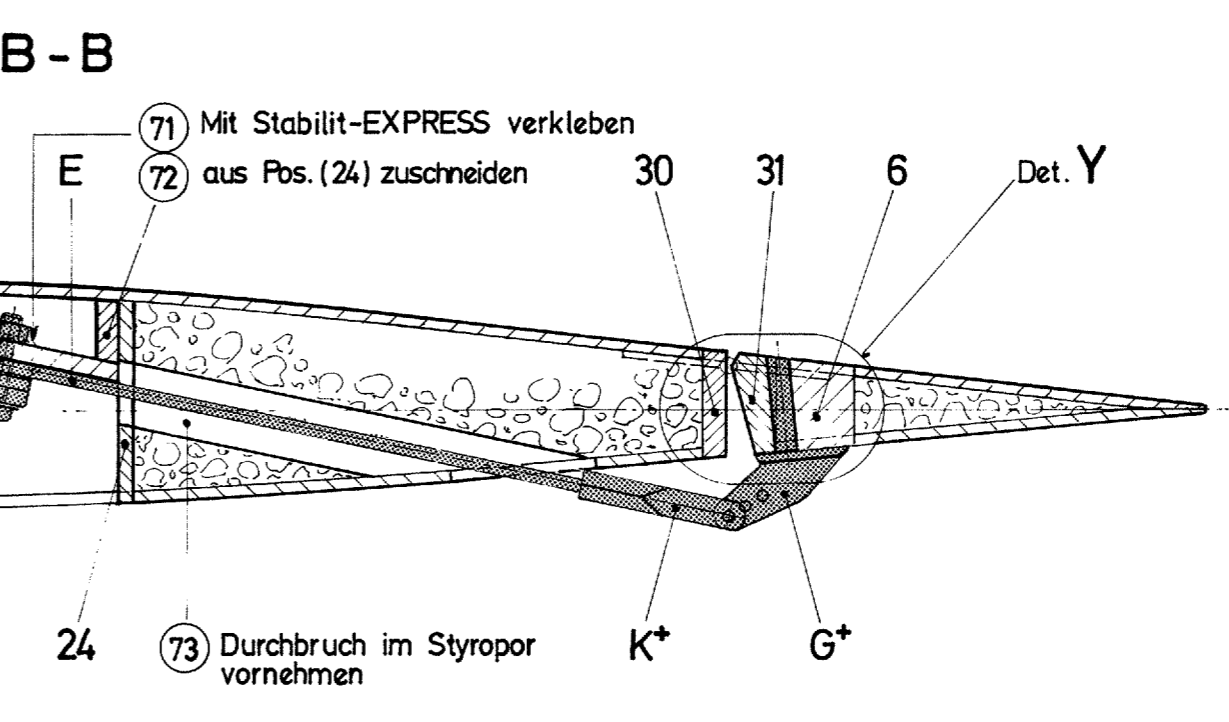
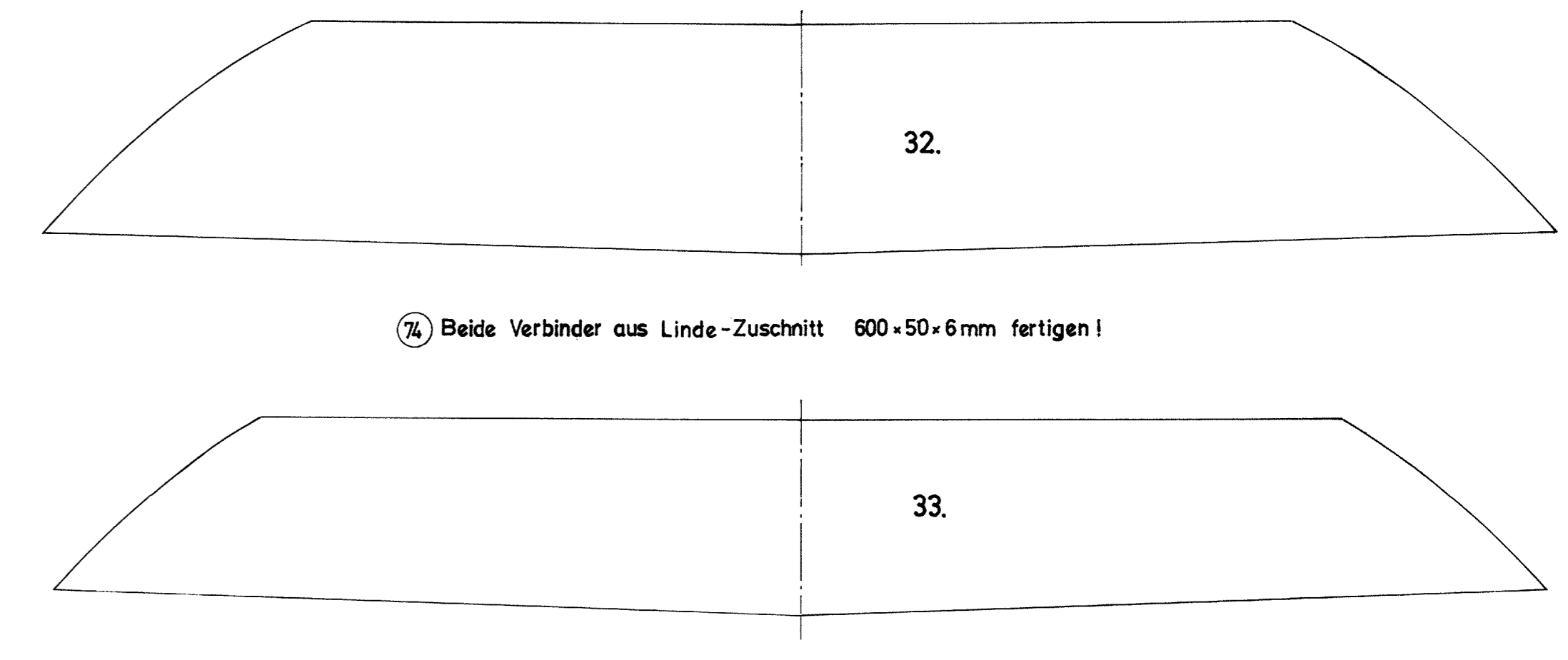
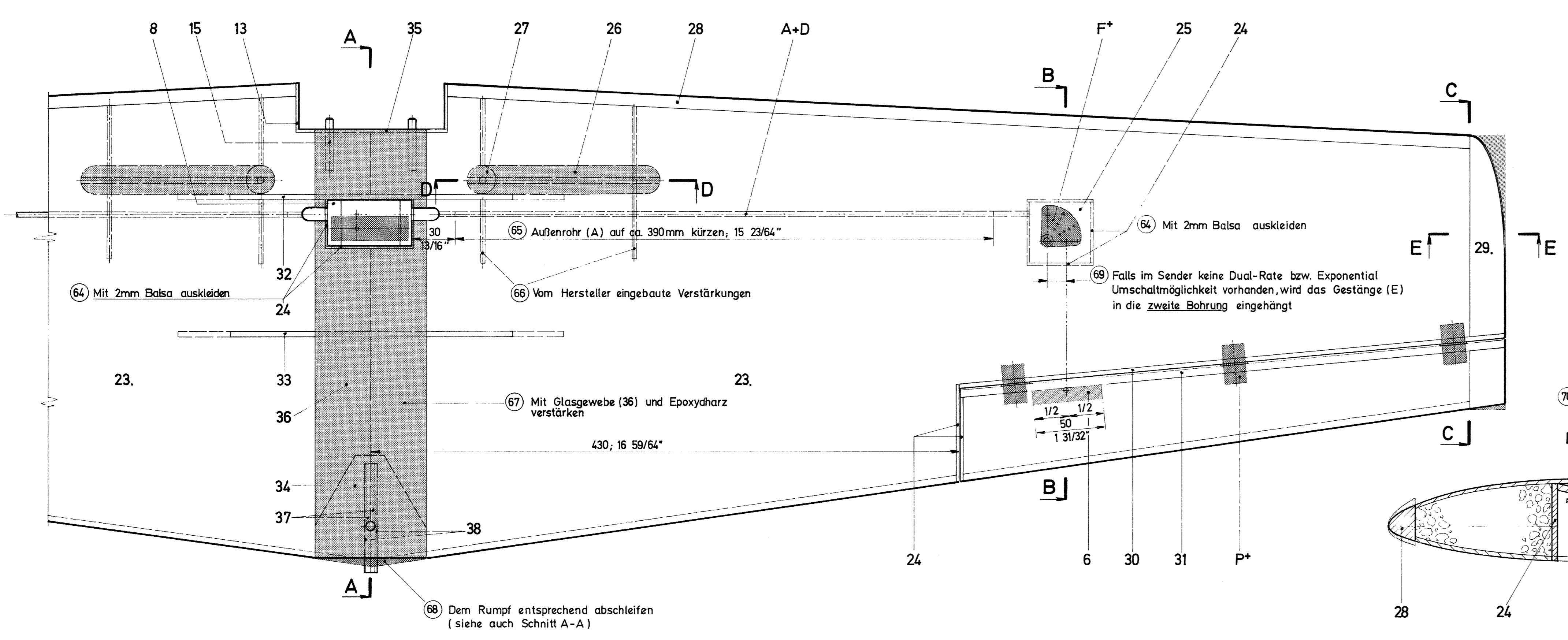

Die Texte sind mit eingekreisten Nummern versehen. Diese Numerierung erleichtert das Auffinden der zugehörigen Fremdsprachigen Texte in der jeweiligen Anleitung.

The texts are provided with encircled numbers. This numbering facilitates the locating of the adjoined texts in the respective instructions.

Les textes ont des numéros encadrés. Ce numérotage facilite de trouver les textes des langues étrangères adjoints dans les instructions respectives.

De teksten zijn van omcirkelde nummers voorzien. Deze nummering vergemakkelijkt het vinden van de bijgevoegde anderstalige teksten van de handleiding.

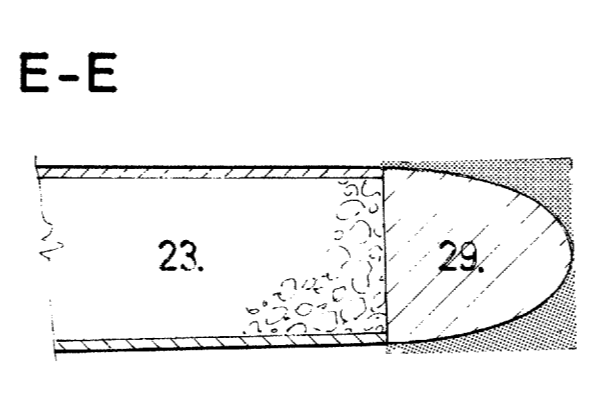

86 FLÜGEL-VORDERANSICHT, M 1:5

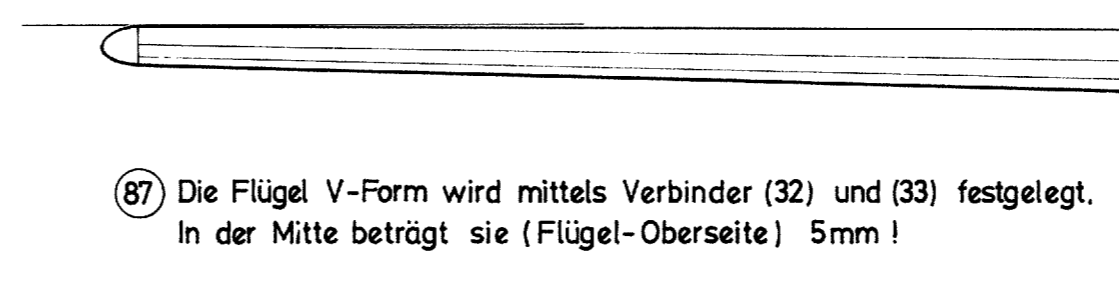

88 Schnitt F-F

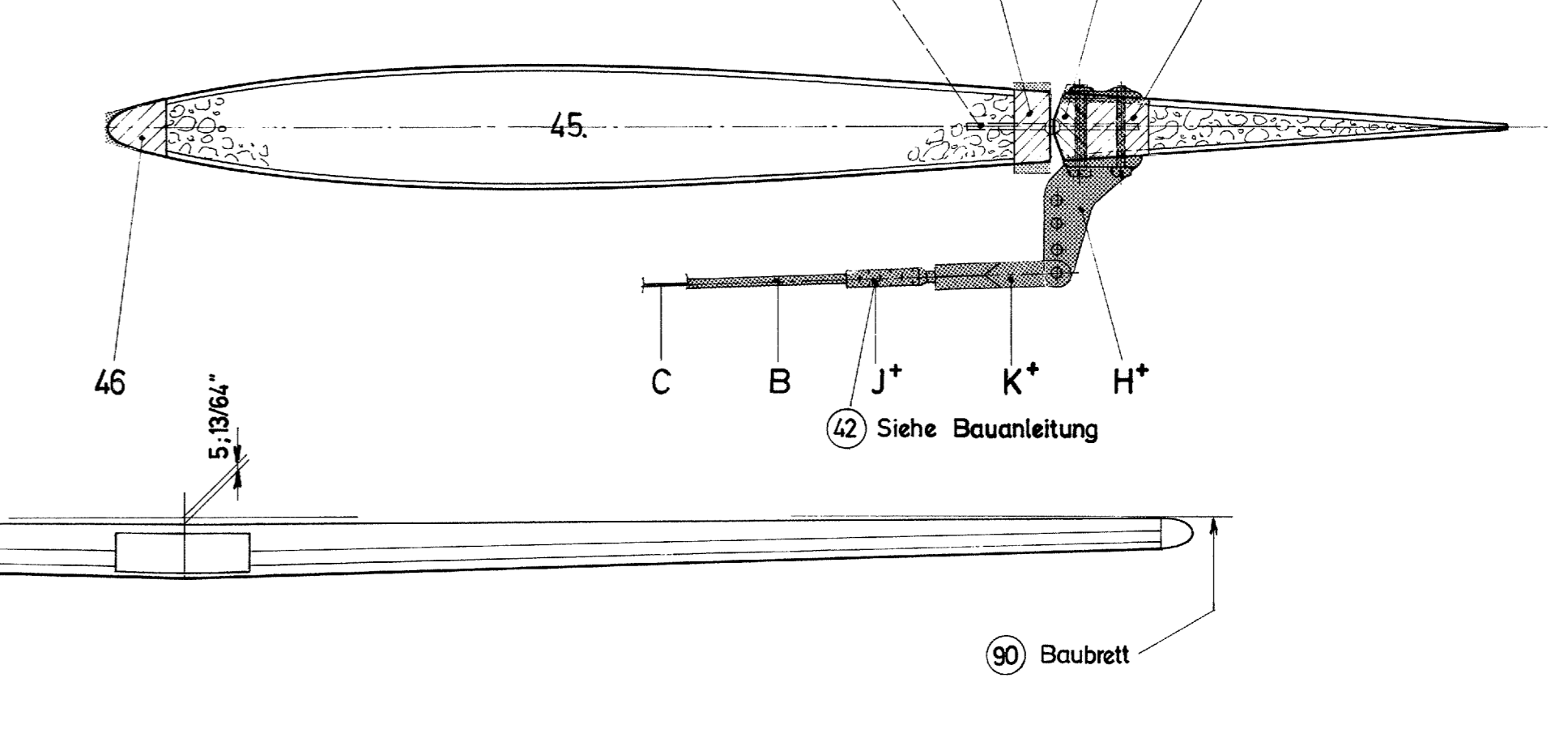

57 ÄNDERUNGEN, DIE DEM TECHNISCHEN FORTSCHRITT DIENEN, VORBEHALTEN!

Printed in Germany 86