

WING L.E. 1/20 sq.
 T.E. 1/32 x 3/32.
 Ribs 1/32 sq.
 Spar 1/32 x 7/32.
 Tips 3 laminations
 1/64 x 1/20.
 L.E. sheet 1/64.

Strip ailerons lower wing.

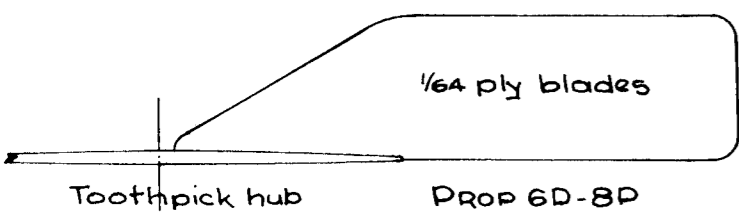

1/64 ply blades

Toothpick hub

PROP 6D-8P

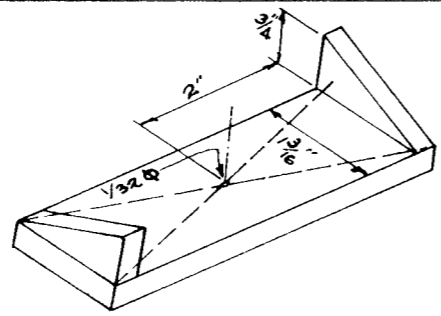

PROP PITCH JIG
 P=8, any dia.
 All 1/4 balsa

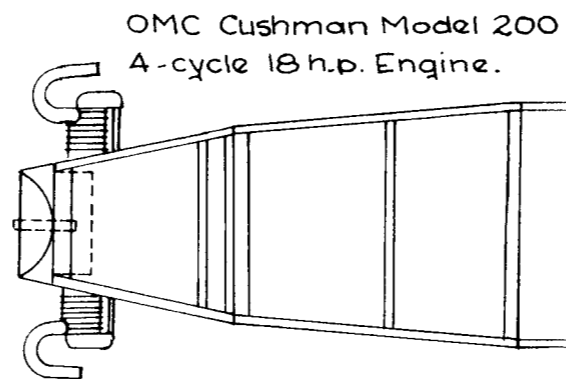

OMC Cushman Model 200
 4-cycle 18 h.p. Engine.

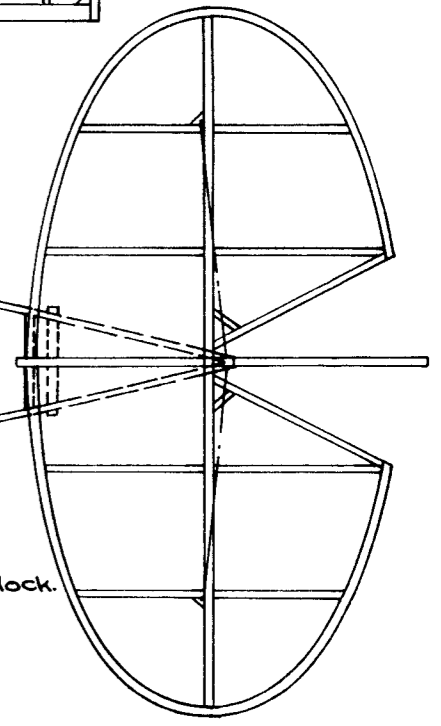

FUSELAGE: .040 sq. & sheet. Cowl 1/64 & 3/32 sh. Balsa noseblock.
 TAIL: Outlines 2 laminations 1/64 x 1/32, spars & ribs 1/32 sq.

Prototype N2180 is painted all white. Struts, tail wheel assembly and lettering is red.

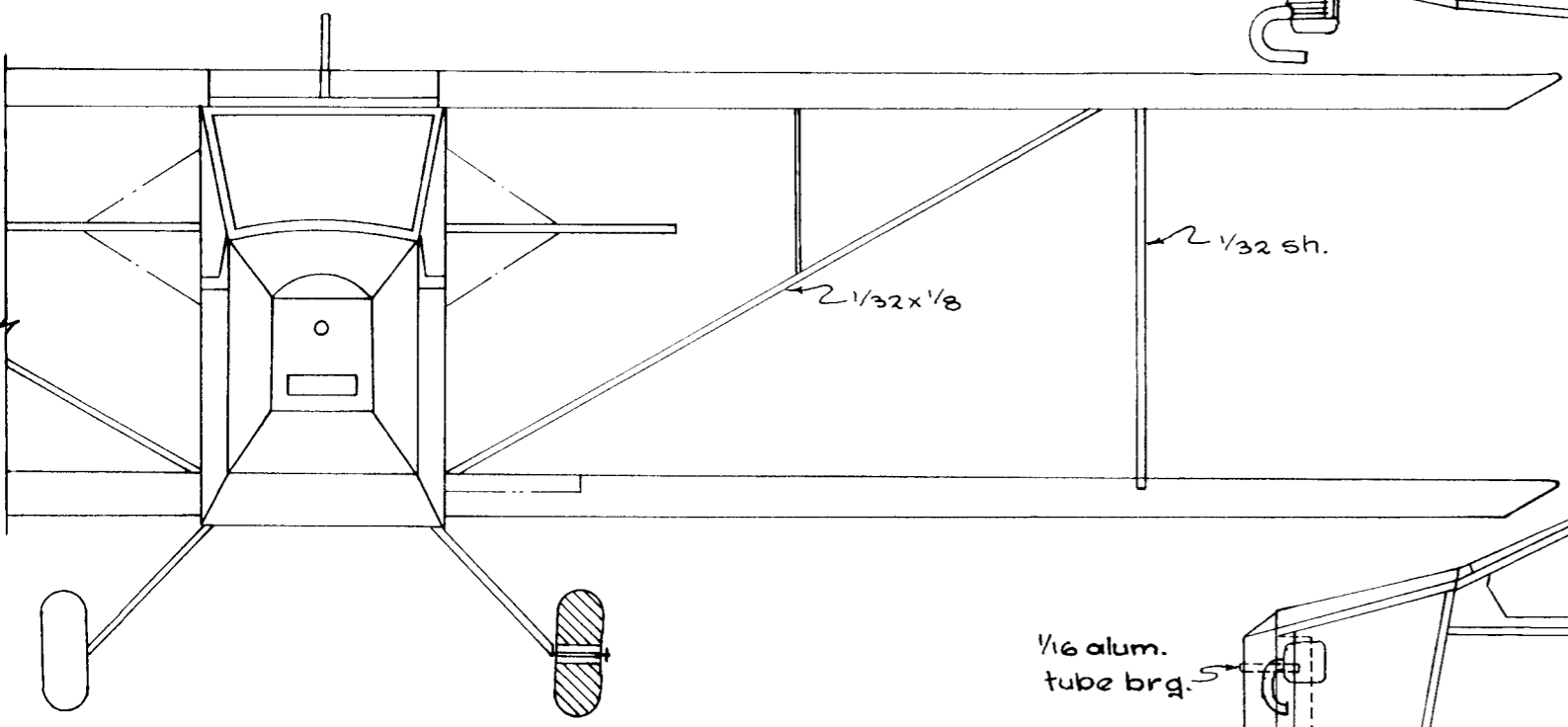

2 1/32 x 1/8

1/32 sh.

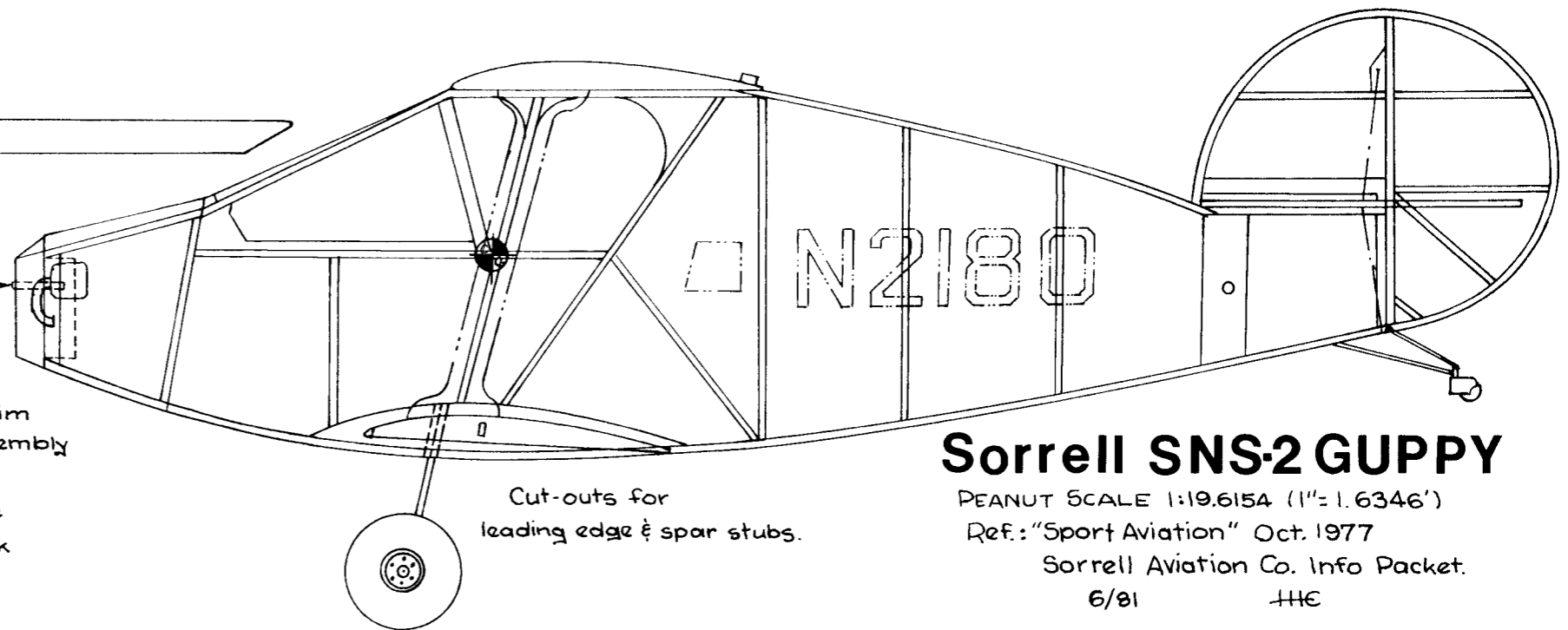

1/16 alum. tube brg.

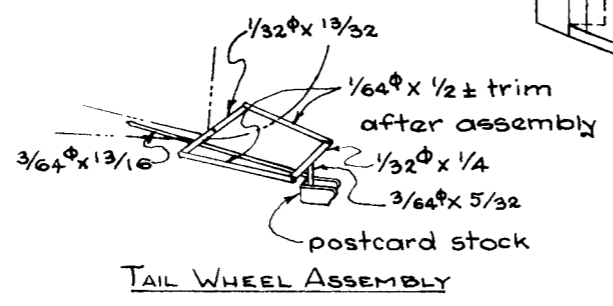

TAIL WHEEL ASSEMBLY

Cut-outs for leading edge & spar stubs.

Sorrell SNS-2 GUPPY

PEANUT SCALE 1:19.6154 (1"=1.6346")
 Ref.: "Sport Aviation" Oct. 1977
 Sorrell Aviation Co. Info Packet.
 6/81 HHC

.020 Music Wire.