

BUILD OR WARP 1/8" WASHOUT INTO BOTH WINGTIPS.

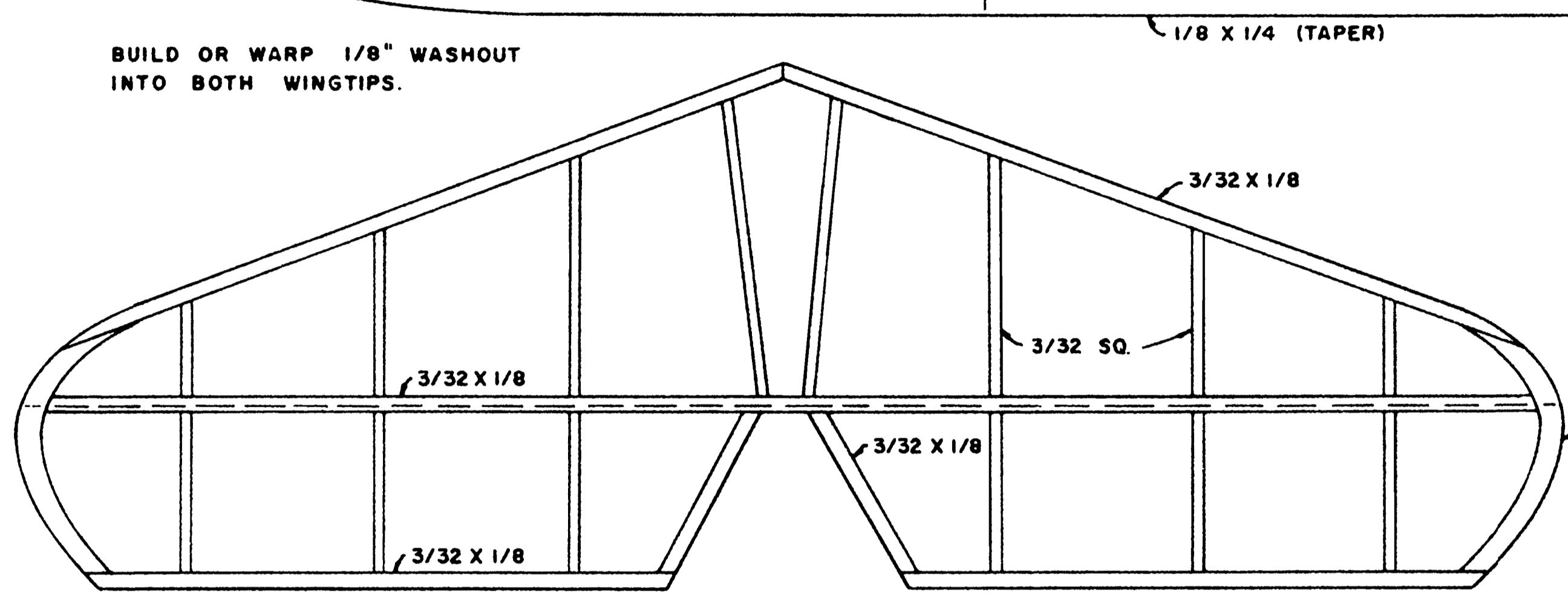

1/16 SHT. WING FAIRING ADD AFTER WING & FUSELAGE ARE MATED

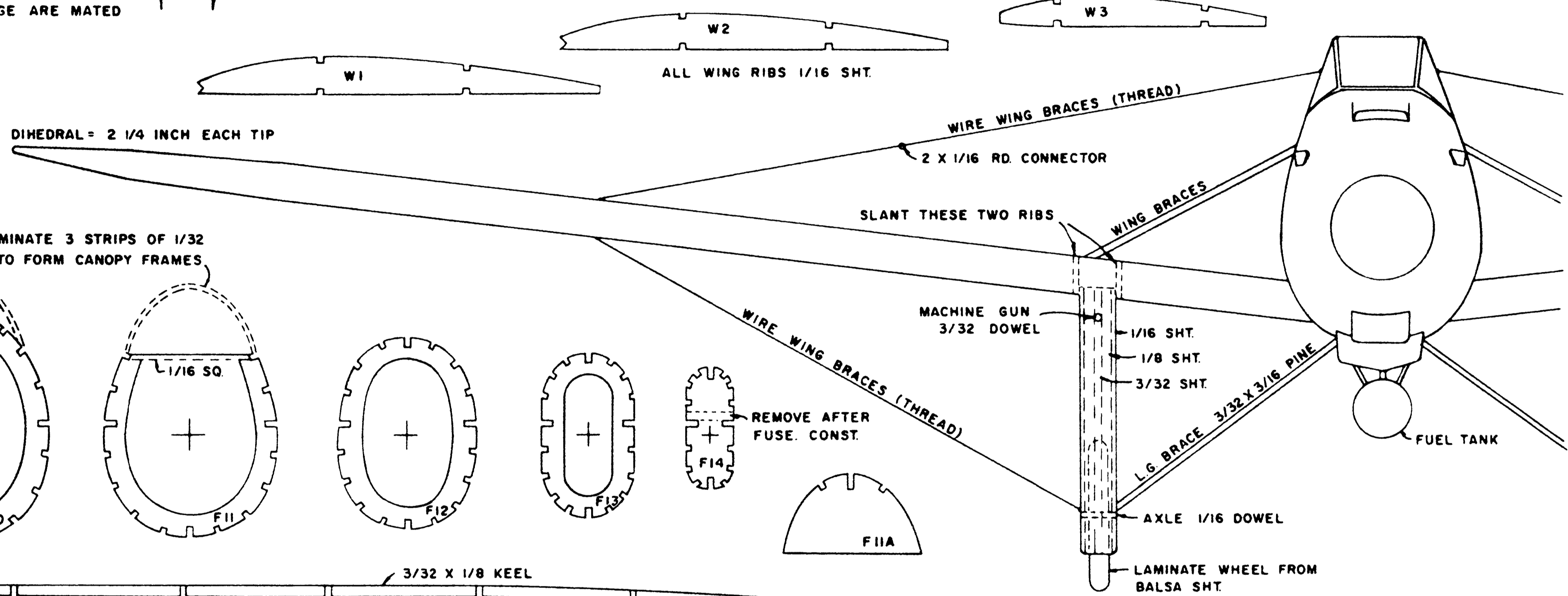

ALL MATERIAL Balsa UNLESS OTHERWISE NOTED

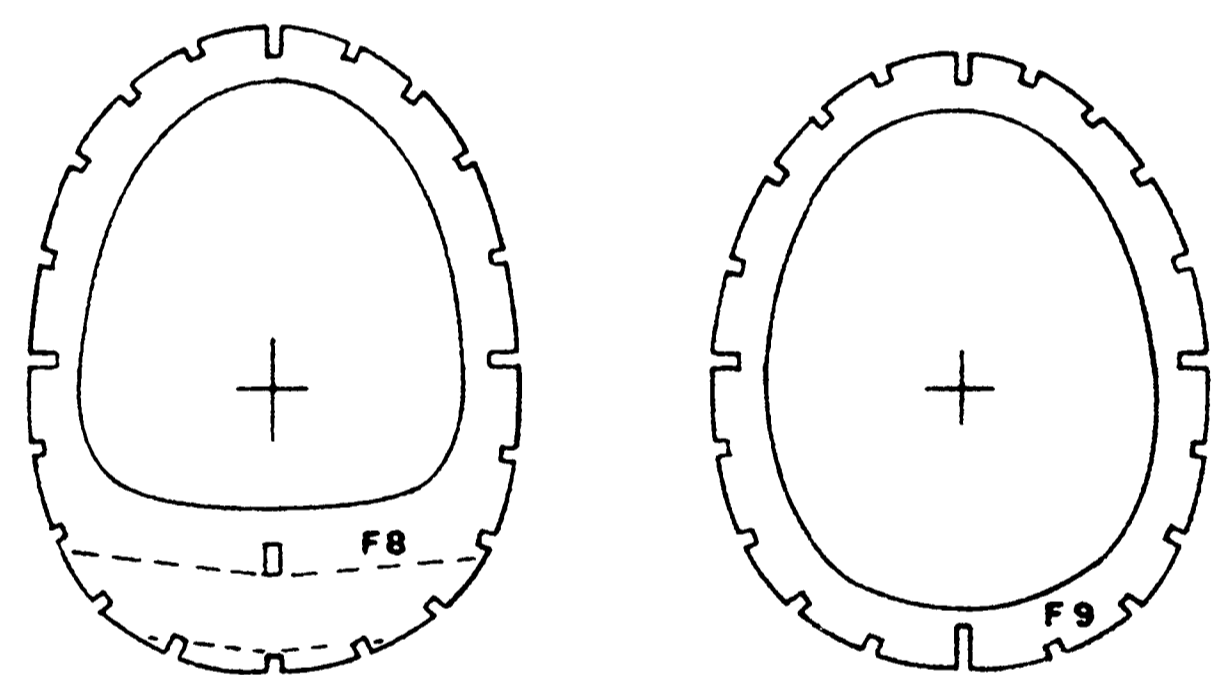

BULKHEADS F4 THRU F14 1/16 SHT. Balsa

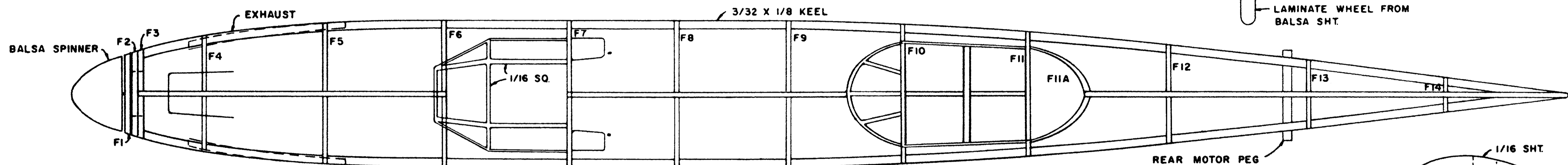

STRINGERS (1/16 SQ. MED. HARD Balsa) NOT SHOWN ON FUSELAGE PLANS. BUILD FUSELAGE BY KEEL & BULKHEAD METHOD, THEN ADD STRINGERS IN PAIRS, ONE ON RIGHT AND ONE ON LEFT. LEAVE BOTTOM WING MOUNT AREA OPEN UNTIL WING IS GLUED IN PLACE, THEN ADD REMAINING STRINGERS. COCKPIT AREAS USE LT. CELLOPHANE, REST OF MODEL COVERED WITH FINE JAPANESE TISSUE.

COLOR SCHEME:
ARMY OLIVE DRAB (GLOSS) - FUSELAGE, WHEEL PANTS, FUEL TANK, TAIL WHEEL.
ARMY YELLOW (GLOSS) - WINGS, STABILIZER, RUDDER.
RED = R. WHITE = W. BLUE = B. BLACK = BK.

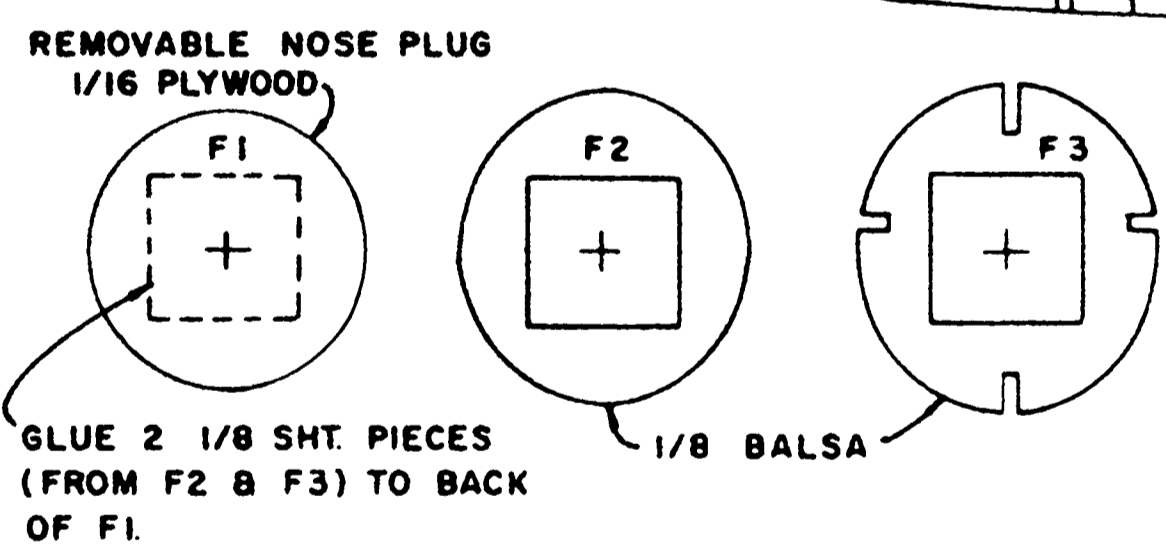
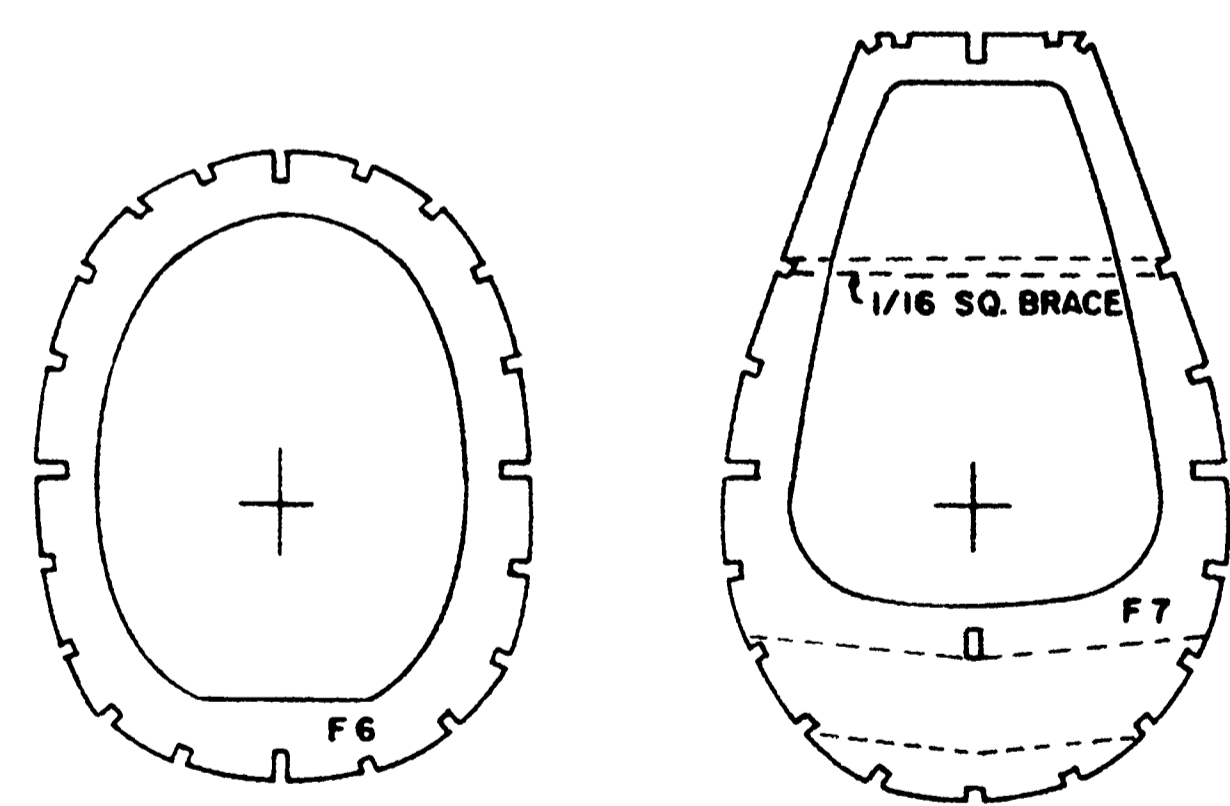

GLUE 2 1/8 SHT. PIECES (FROM F2 & F3) TO BACK OF F1.

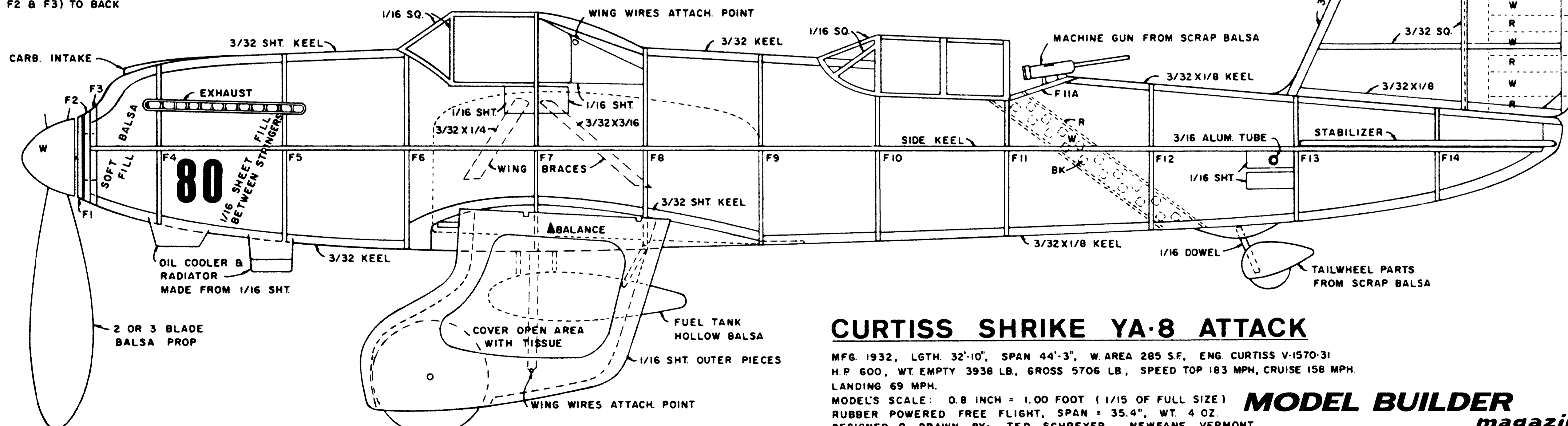
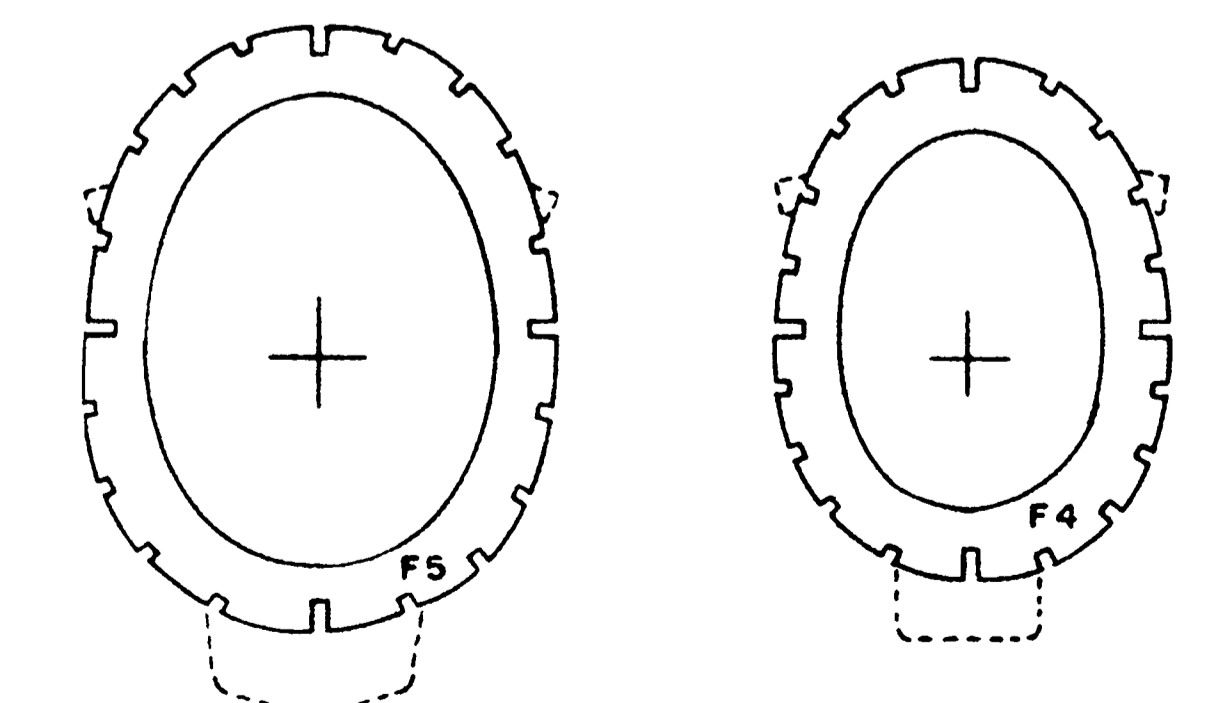

REFERENCES:
COMPLETE MODEL AIRCRAFT MANUAL, EDWIN T. HAMILTON: 1933.
WINGS MAGAZINE, FEB. 1987, "ARMY AIR CORPS EDITION 1920-1940"
AMERICAN COMBAT PLANES, RAY WAGNER: 1960.
AIR FORCE, MARTIN CAIDIN: 1957.

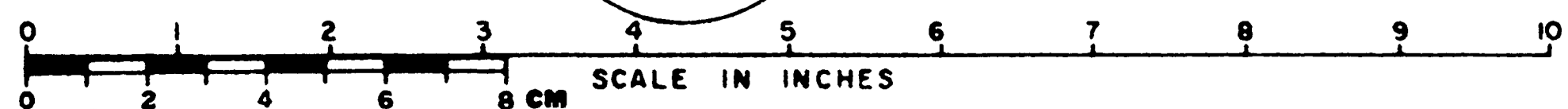

CURTISS SHRIKE YA-8 ATTACK

MFG. 1932, LGTH. 32'-10", SPAN 44'-3", W. AREA 285 S.F., ENG. CURTISS V-1570-31
H.P. 600, WT. EMPTY 3938 LB., GROSS 5706 LB., SPEED TOP 183 MPH, CRUISE 158 MPH.
LANDING 69 MPH.
MODEL'S SCALE: 0.8 INCH = 1.00 FOOT (1/15 OF FULL SIZE)
RUBBER POWERED FREE FLIGHT, SPAN = 35.4", WT. 4 OZ.
DESIGNED & DRAWN BY: TED SCHREYER, NEWFANE, VERMONT
SEPT. 19, 1987 ALL RIGHTS RESERVED

MODEL BUILDER magazine

Plan No: 11911