

STEP ONE

LAY THE FUSELAGE SIDE ON THE PLAN AND MARK THE POSITION OF F-1. GLUE ON THE NOSE DOUBLER AND THE SIDE DOUBLER LEAVING A 1/8" SLOT FOR F-1.

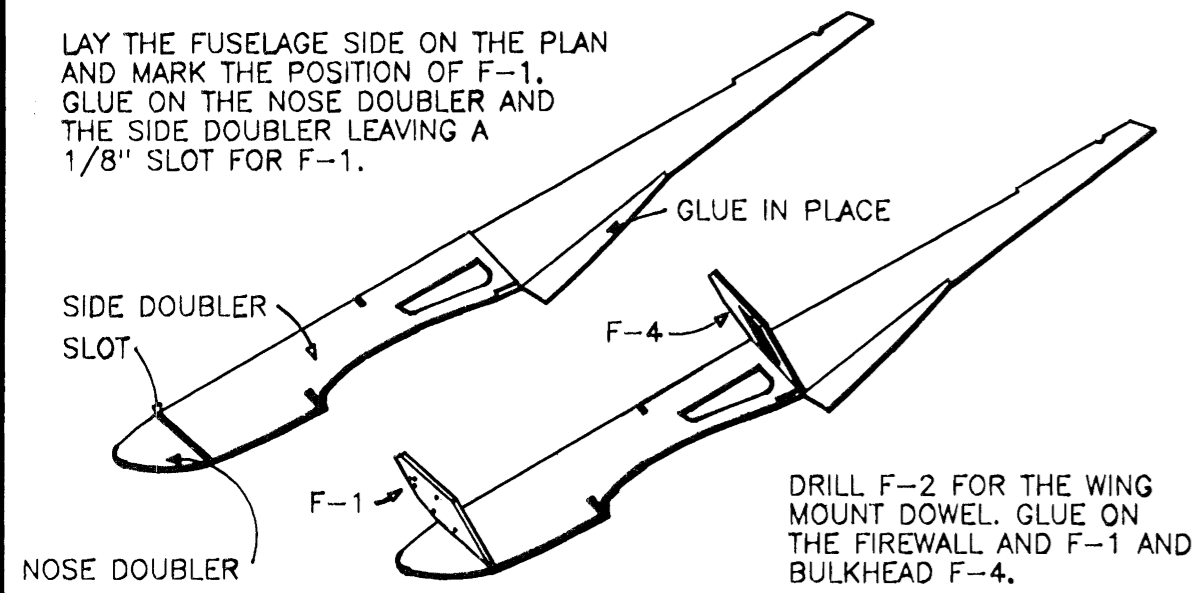

DRILL F-2 FOR THE WING MOUNT DOWEL. GLUE ON THE FIREWALL AND F-1 AND BULKHEAD F-4.

STEP TWO

GLUE ON THE OTHER FUSELAGE SIDE. GLUE IN F-2, F-3 AND F-5.

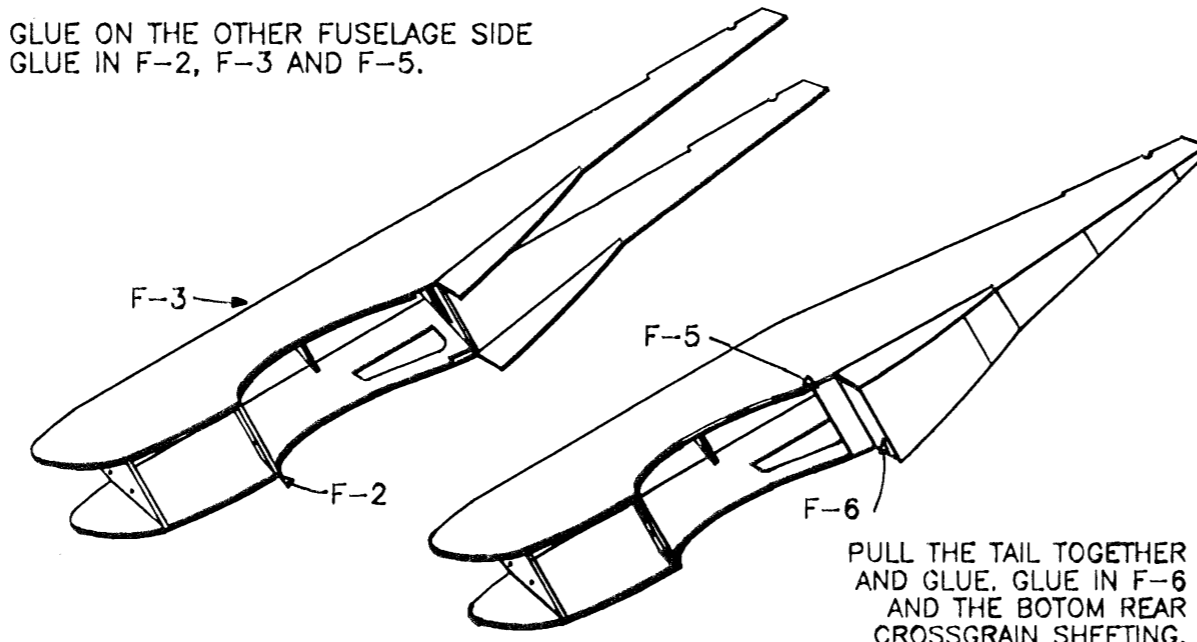

STEP THREE

GLUE ON THE TOP FRONT SIDES. GLUE ON THE TOP FRONT CROSSGRAIN SHEETING.

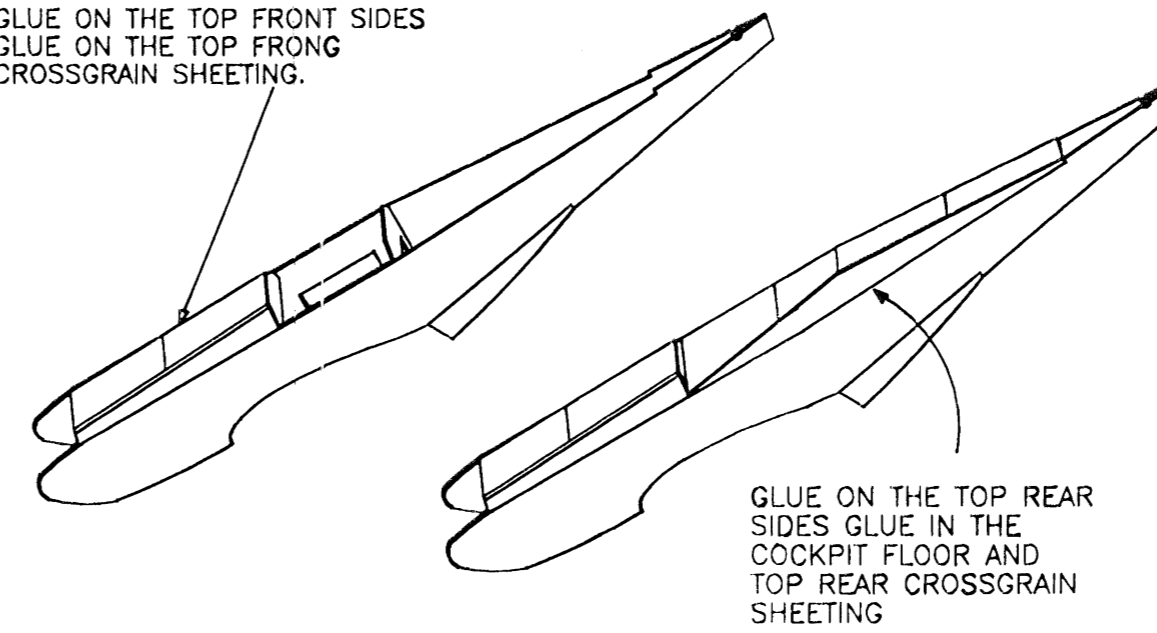

INSTRUCTIONS

TOOLS AND ADHESIVES NEEDED TO BUILD THIS MODEL ARE: X-ACTO KNIFE, SCREWDRIVERS, PLIERS AND A DRILL WITH 1/16", 1/8" AND 5/32" DRILL BITS, AND BOTH MEDIUM AND FINE SANDPAPER. FOR GLUE WE RECOMMEND MEDIUM CYA GLUE FOR ALL WOOD TO WOOD JOINTS. FOR WOOD TO FOAM USE WHITE GLUE OR EPOXY. USE EPOXY ONLY TO JOIN THE TWO WING HALVES.

STEP ONE: BUILD THE MODEL USING THE PICTURE SEQUENCE AS A GUIDE. LAY THE FUSELAGE OVER THE PLAN AND NOTE THE MARKS VISIBLE ON THE PLAN ABOVE AND BELOW F-1. USE THESE MARKS TO POSITION THE DOUBLERS. THE NOSE DOUBLER IS GLUED ON AHEAD OF THE FORWARD MARKS. THE SIDE DOUBLER IS GLUED ON BEHIND THE REAR MARKS. THIS LEAVES A 1/8" SLOT FOR F-1 BETWEEN THE DOUBLERS. GLUE THE REAR PORTION OF THE SCOOP TO THE FUSELAGE SIDES. DRILL F-1 FOR THE ENGINE MOUNT AND THE FUEL LINES. GLUE IN THE BLIND NUTS. DRILL F-2 FOR THE WING MOUNT DOWEL.

STEP TWO: GLUE ON THE OTHER FUSELAGE SIDE. GLUE IN F-2, F-3, F-5 AND F-6. PULL THE FUSELAGE SIDES TOGETHER AT THE TAIL AND GLUE KEEPING THE FUSELAGE STRAIGHT. ADD THE CROSSGRAIN Balsa BOTTOM REAR SHEETING.

STEP THREE: BEVEL SAND THE BOTTOM EDGES OF THE TOP SIDES. GLUE THE TOP FRONT SIDES IN PLACE. BEVEL SAND THE TOP EDGES. THEN GLUE ON THE CROSSGRAIN Balsa TOP CUT FROM THE SHEET STOCK, STARTING FROM THE BACK, GLUE ON THE TOP REAR SIDES. SAND THE TOP EDGES, THEN GLUE ON THE COCKPIT FLOOR AND TOP REAR CROSSGRAIN Balsa SHEETING. BOTH CUT FROM SHEET STOCK.

STEP FOUR: GLUE THE 1/8" X 1/4" Balsa STRIPS TO THE TRAILING EDGE OF THE WING PANELS. ASSEMBLE AND BEND THE ALERON LINKAGE TO MATCH THE PLAN. NOTCH THE INBOARD SECTION FOR THE ALERON LINKAGE AND GLUE IN PLACE. FIT THE ALERONS SO THERE IS A 3/32" SPACE BETWEEN THE INBOARD SECTION AND THE ALERON. AFTER JOINING THE WING PANELS, LIGHTLY SAND OFF THE FLASHING ALONG THE LEADING EDGE AND THE LITTLE BUMPS ON THE SURFACE WITH FINE SANDPAPER (220 GRIT). BEFORE COVERING, APPLY A STRIP OF 3/4" WIDE FIBERGLASS STRAPPING TAPE FROM TIP TO TIP, TOP AND BOTTOM ALONG THE THICKEST SECTION OF THE WING.

STEP FIVE: FIT THE WING INTO THE FUSELAGE. USING THE 1/8" HOLE IN F-2 AS A GUIDE, DRILL A HOLE INTO THE FOAM WING FOR THE WING MOUNT DOWEL. EPOXY THE DOWEL INTO THE WING. INSTALL THE REAR MOUNTING SCREW. REMOVE THE SCREW AND APPLY A DROP OF GLUE INTO THE HOLES TO HARDEN THE WOOD AROUND THE SCREW. REMOUNT THE WING. GLUE F-7 TO THE WING LEAVING A THIN GAP BETWEEN F-6 AND F-7. GLUE ON THE TWO FORWARD SCOOP SIDES AND F-8. GLUE ON THE BOTTOM CROSSGRAIN SHEETING. CUT A HOLE FOR ACCESS TO THE MOUNTING SCREW.

COVERING AND TRIM: BEFORE COVERING, SAND THE MODEL WITH LOW TEMPERATURE FILM. HIGH TEMPERATURES WILL MELT THE FOAM WING. COVER THE FUSELAGE AND TAIL PARTS SEPARATELY. CUT AWAY A STRIP OF FILM WHERE THERE IS TO BE A GLUE JOINT. FIT THE CANOPY AND CUT AWAY A 1/8" WIDE STRIP OF COVERING UNDER THE CANOPY EDGES AND EPOXY IN PLACE. CUT OUT AND APPLY THE INSIGNIA OVER SOAPY WATER OR SPRAY CLEANER TO WORK OUT ANY BUBBLES UNDER THE DECAL. THE POINT OF THE STAR IS UP ON THE FUSELAGE AND FORWARD ON THE WING.

STEP SIX: USE TWO STANDARD MINI OR MICRO SERVOES FOR ALERON AND ELEVATOR CONTROL. BATTERY PACKS FROM 225-550 MAH CAN BE USED. USE THE SIZE OF THE PACK TO ADJUST THE BALANCE. WE USED STANDARD PACKS IN OUR TEST MODELS. SET THE CONTROL MOVEMENTS AS SHOWN ON THE PLAN AND ADJUST IF NEEDED.

ENGINE AND FLYING: ANY OF THE COX .049 ENGINES CAN BE USED, BUT WE PREFER THE TD .049 WITH A SEPARATE FUEL TANK TO GIVE THE MOST RELIABLE PERFORMANCE. USE A COX 6 X 3 GRAY COMPETITION PROP AND COX SUPER POWER FUEL FOR THE BEST PERFORMANCE. FLY THE MODEL FROM A GRASS FIELD SINCE THERE IS NO LANDING GEAR. LAUNCH THE MODEL BY AN UNDERHAND TOSS, HOLDING THE MODEL JUST AHEAD OF THE CANOPY. FLY IT UP, TRIM IT, AND WRING IT OUT. THE SIMPLE 51 IS FAST AND AGILE. LOOK OUT FOR SIMPLY 109'S THAT MIGHT WANT TO MIX IT UP OR OTHER SIMPLE 51'S THAT WANT TO RACE.

STEP FOUR

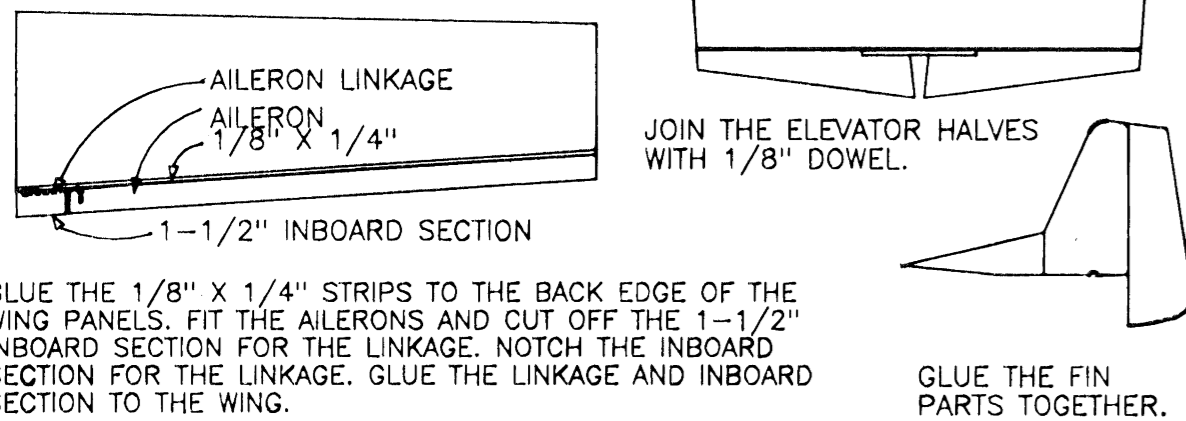

GLUE THE 1/8" X 1/4" STRIPS TO THE BACK EDGE OF THE WING PANELS. FIT THE ALERONS AND CUT OFF THE 1-1/2" INBOARD SECTION FOR THE LINKAGE. GLUE THE LINKAGE AND INBOARD SECTION TO THE WING.

EPOXY THE WING PANELS TOGETHER, BLOCKING UP ONE WING TIP 2". APPLY STRAPPING TAPE TOP AND BOTTOM FROM TIP TO TIP.

STEP FIVE

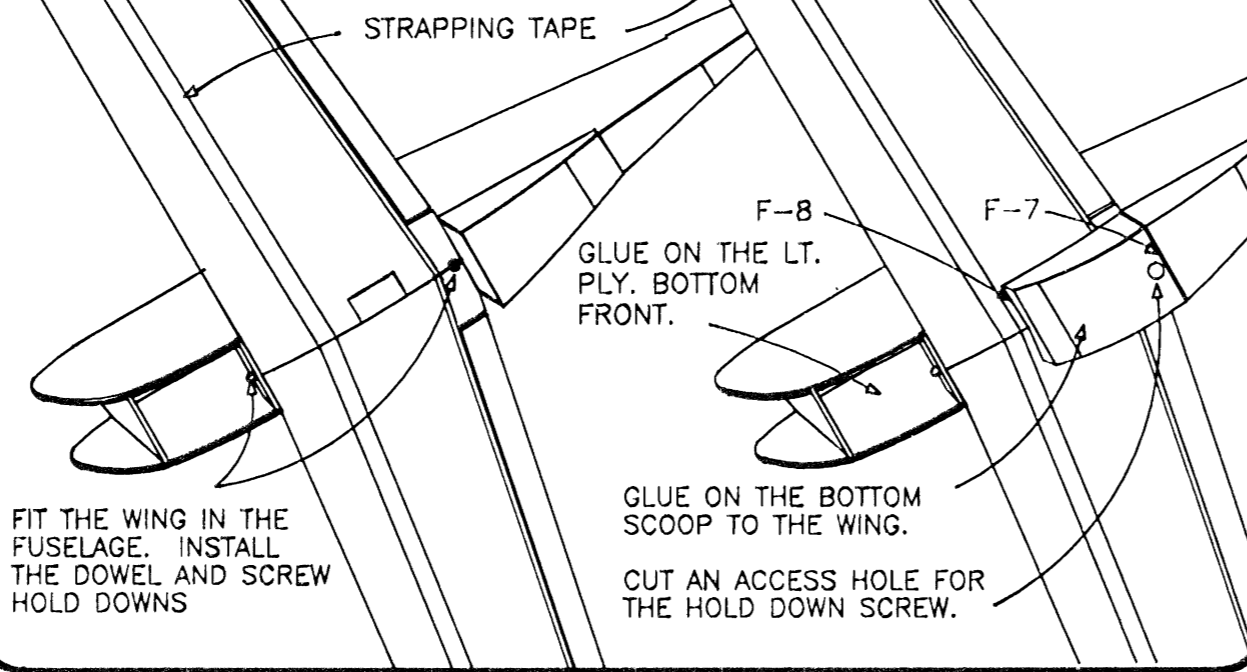

STEP SIX

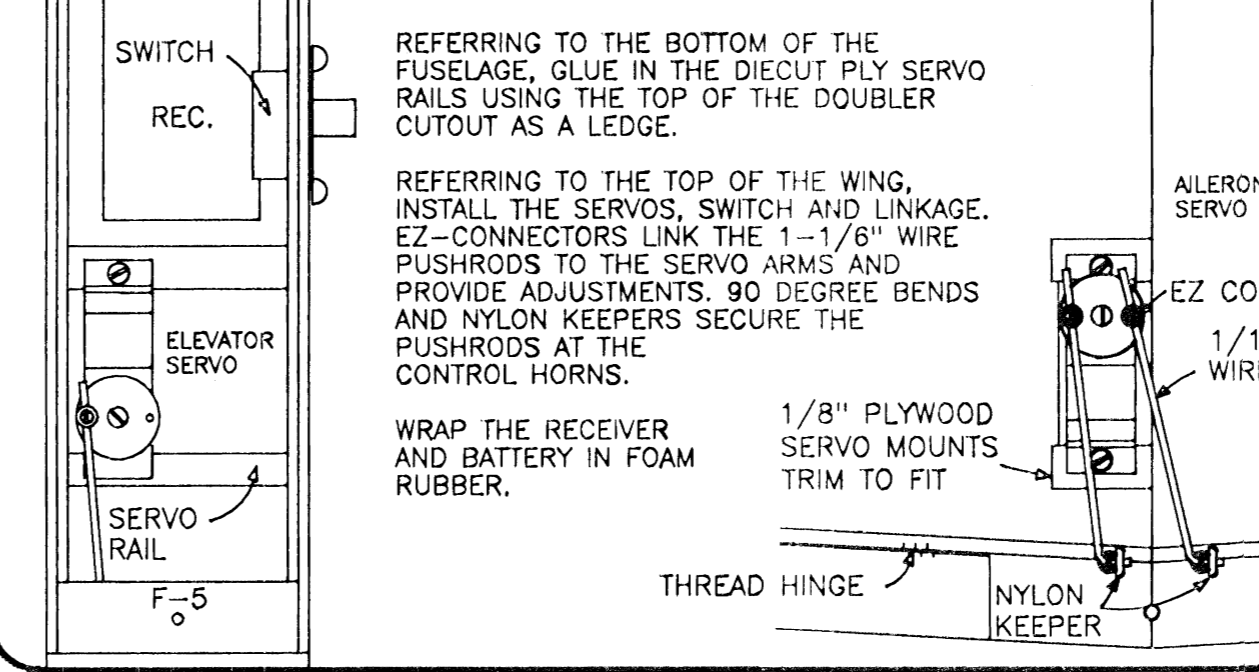

REFERRING TO THE BOTTOM OF THE FUSELAGE, GLUE IN THE DIECUT PLY RAILS USING THE TOP OF THE DOUBLER CUTOUT AS A LEDGE.

REFERRING TO THE TOP OF THE WING, INSTALL THE SERVO, SWITCH AND LINKAGE. EZ-CONNECTORS LINK THE 1-1/8" WIRE PUSHRODS TO THE SERVO ARMS AND PROVIDE ADJUSTMENTS. 90 DEGREE BENDS AND NYLON KEEPERS SECURE THE PUSHRODS AT THE CONTROL HORNS.

WRAP THE RECEIVER AND BATTERY IN FOAM RUBBER.

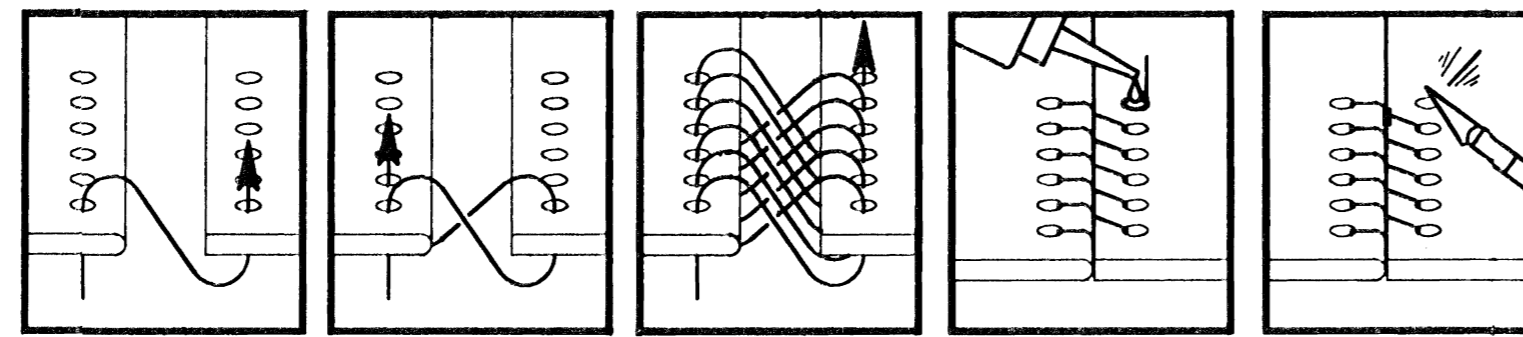

STEP 1 STEP 2 STEP 3 STEP 4 STEP 5

FIGURE 8 HINGE TECHNIQUE

DRILL MOTOR MOUNT HOLES 1/8" DRILL. FUEL LINE HOLES 5/32"

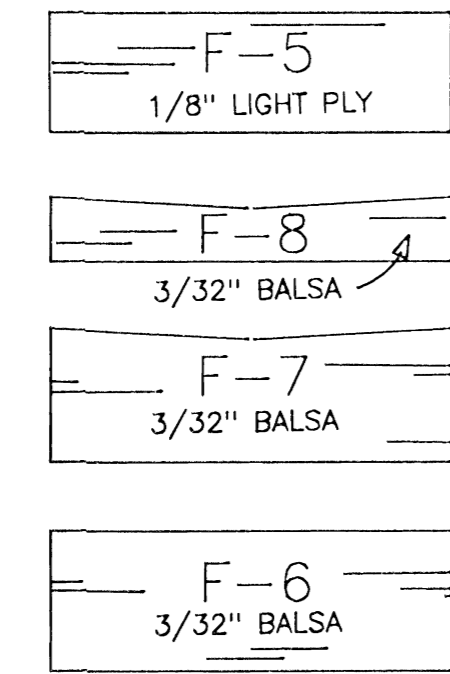
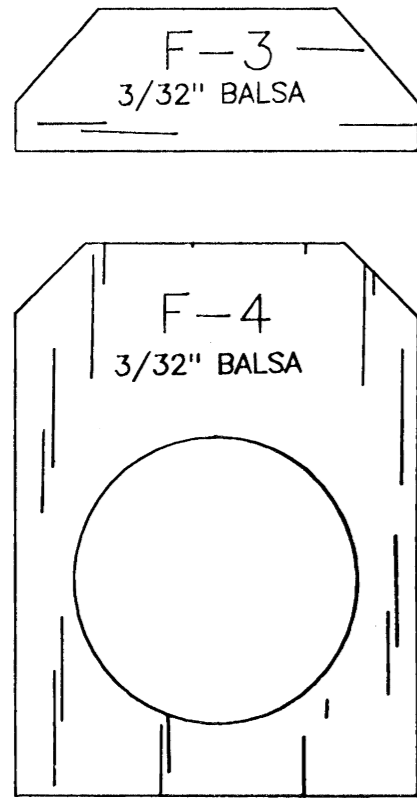
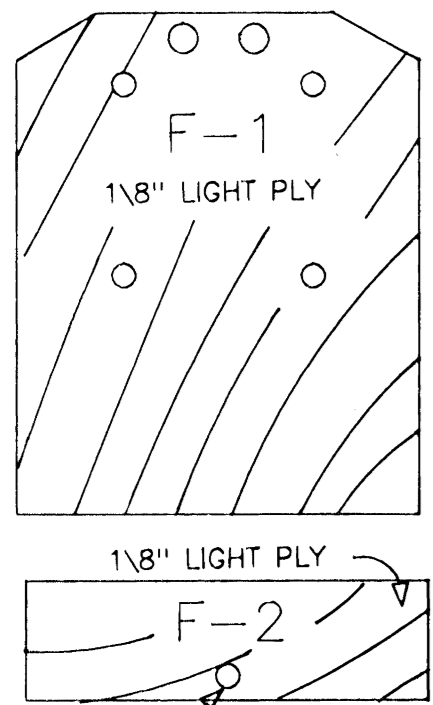

TWO SUPPLIED, ONE REQUIRED

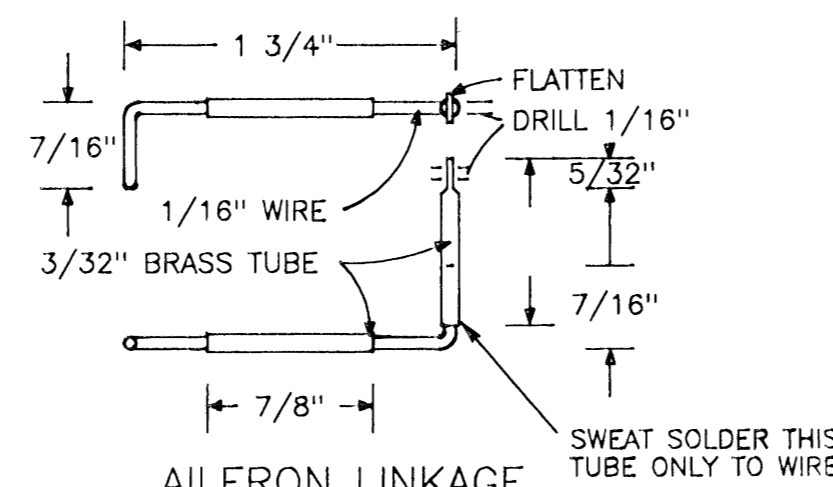

AILERON LINKAGE MAKE ONE RIGHT AND ONE LEFT

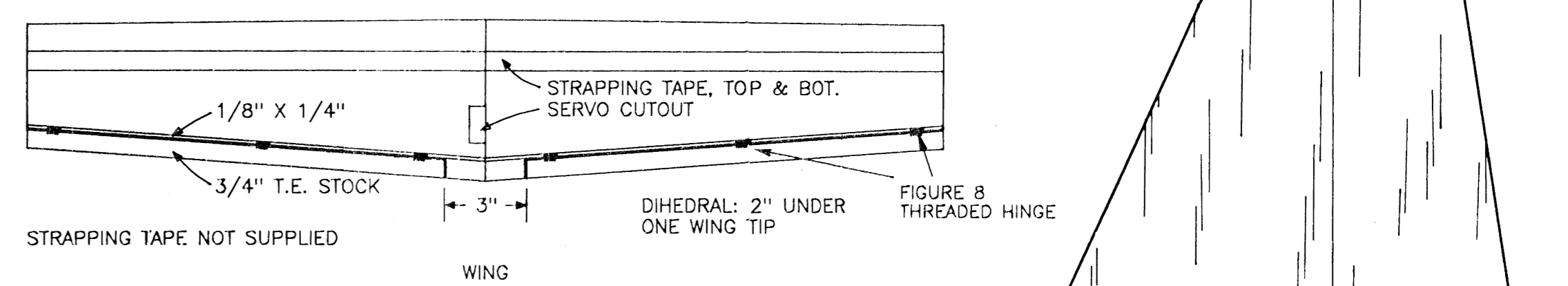
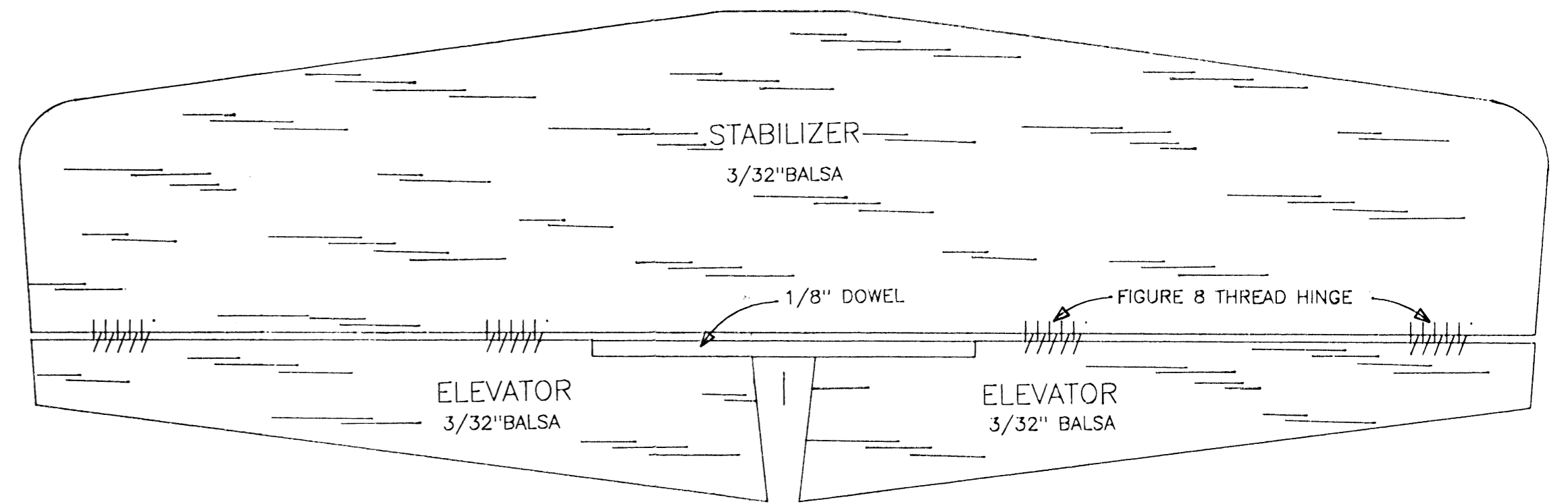

COX TD .049 ENGINE SHOWN ON ACE 1/2A MOTOR MOUNT

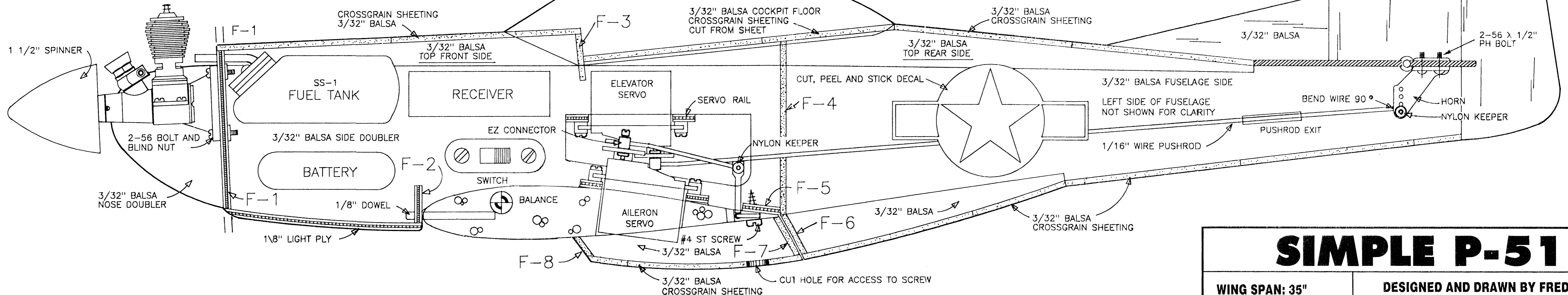

SIMPLE P-51

WING SPAN: 35"
WING AREA: 188 SQ IN
LENGTH: 26-1/4"
WEIGHT: 18 OZ
ENGINE: .049
RADIO: 2 CHANNEL

DESIGNED AND DRAWN BY FRED REESE

© 1993 ACE R/C, INC.

ACE R/C, INC.

116 W 19 ST, POB 472, HIGGINSVILLE, MO 64037-0472

CONTROL MOVEMENT
AILERON: 5/32" UP AND DOWN
ELEVATOR: 3/8" UP AND DOWN