

ALETTONI IN DEPRON DA 6 mm SAGOMATO

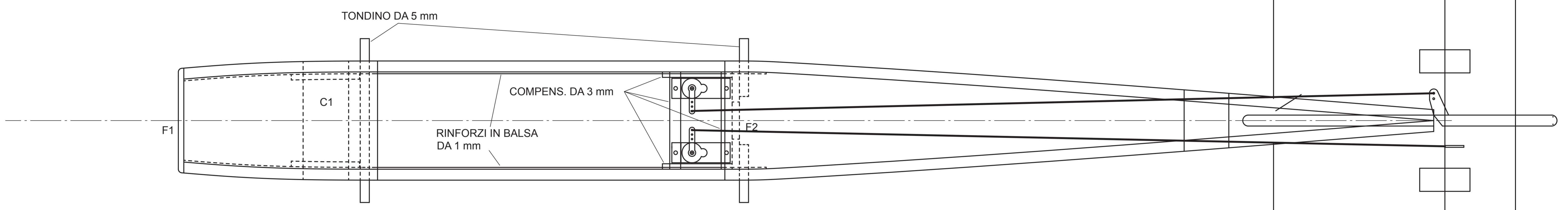

TUTTO L'AEREO E' COSTRUITO IN DEPRON, SALVO DIVERSA INDICAZIONE  
 LA FUSOLIERA E' IN DEPRON DA 6 mm  
 LE CENTINE DELLE ALI SONO IN DEPRON DA 3 mm TRANNE LE DUE CENTRALI CHE SONO DA 6 mm  
 I PIANI DI CODA SONO IN DEPRON DA 6 mm

