

SLY

Conception / dessin : Pascal Delannoy (Mai 2004)

Envergure : 90 cm
Longueur : 90 cm
Poids : 230 à 290 g
(195 g avec un équipement light)
Surface : 17 dm²
Charge alaire : 14 à 17 g/dm²
(11 g/dm² avec un équipement light)

Equipements :
Motorisation : Hacker B26S réduite 4/1
ou même classe de puissance type LRK
Hélice : 9x6" et 10x4,7" APC SF ou GWS
Accus : Lipo Kokam HD 350 7,4 V
et 1200 ou E-Tec 1200 11,1 V
Servos : 4 à 6 g GWS ou équivalent

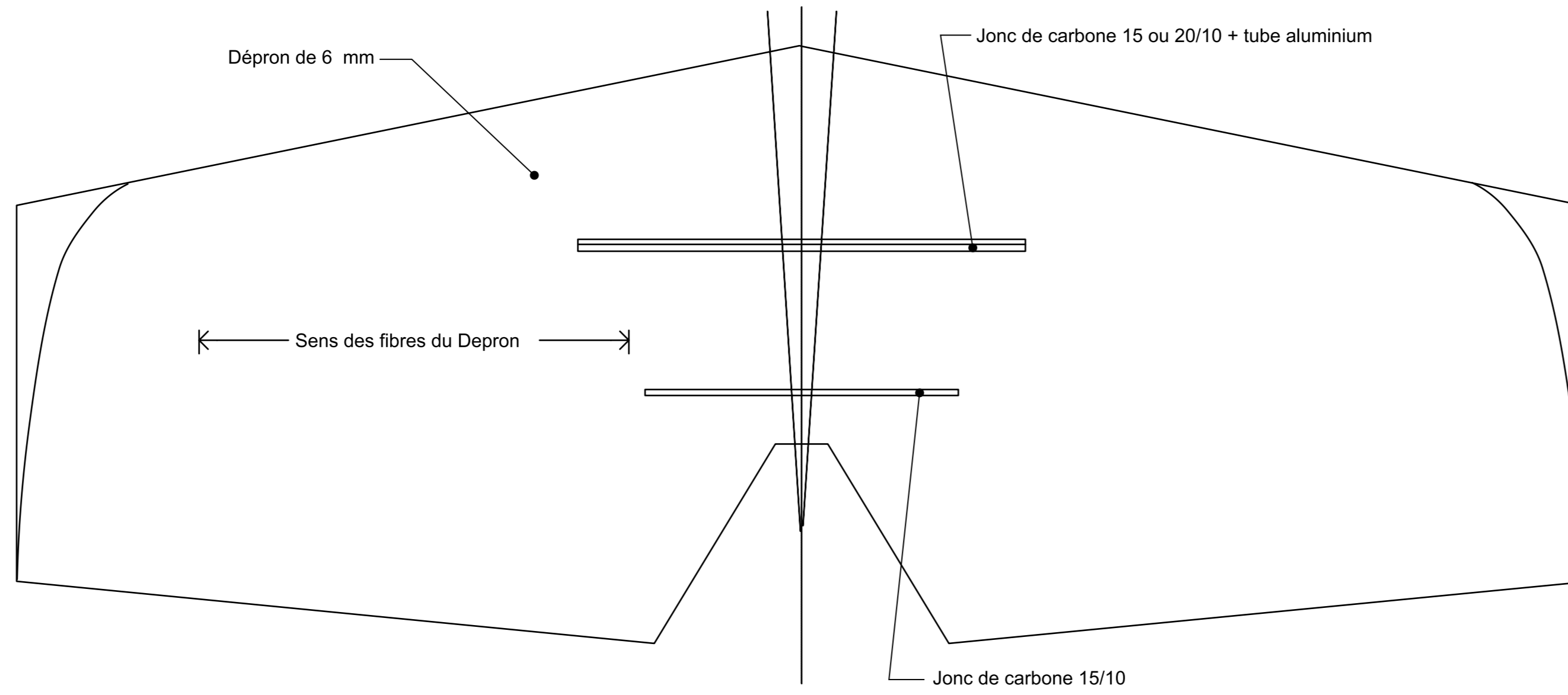

Le stabilisateur entier est découpé puis après collage des tubes aluminium il est coupé en 2 pièces

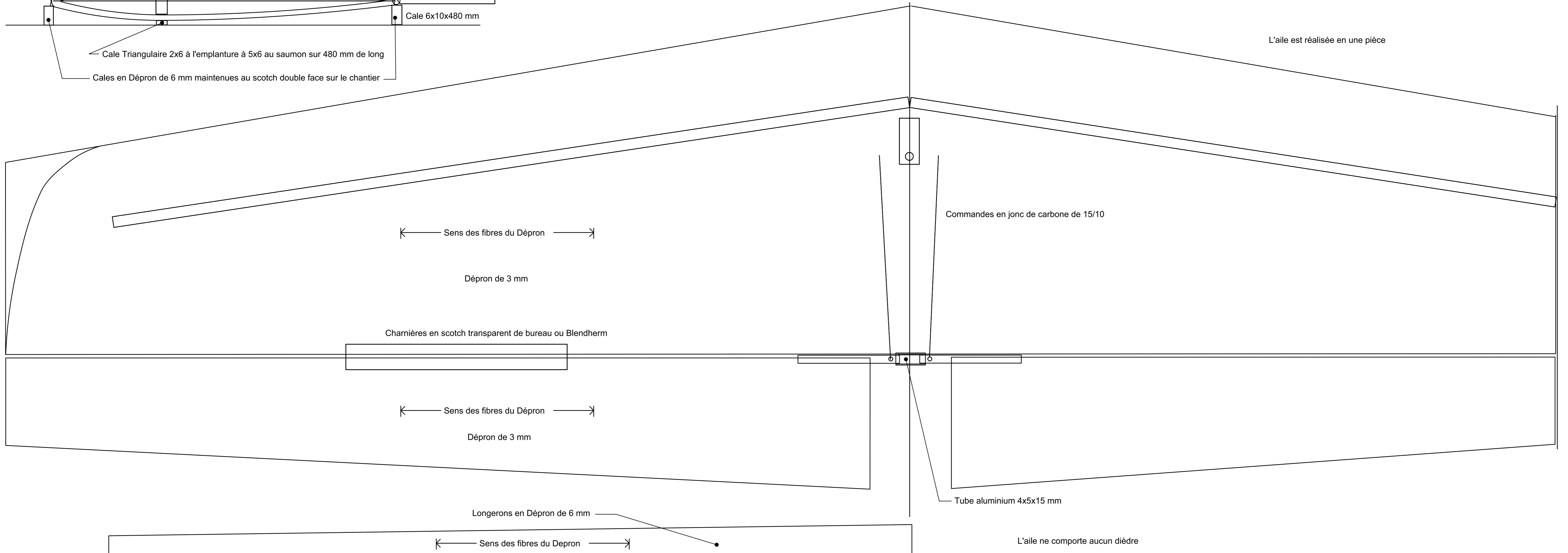
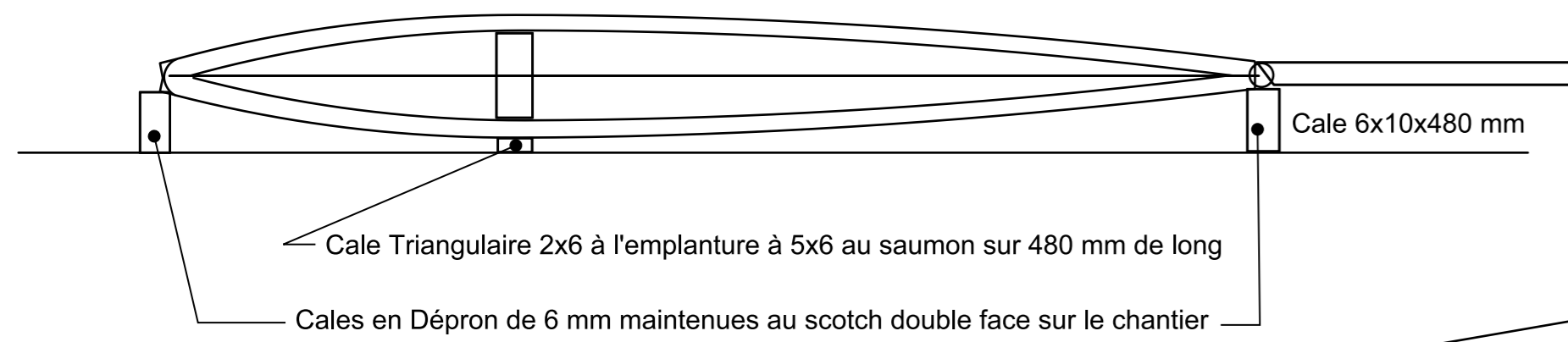
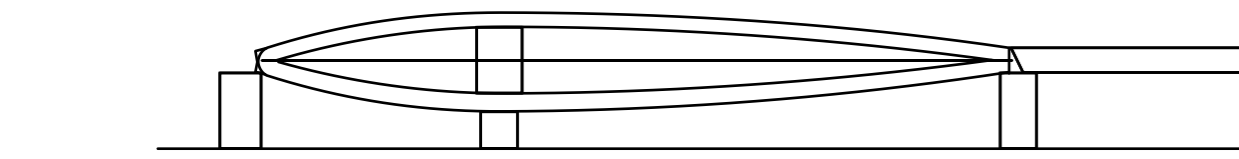
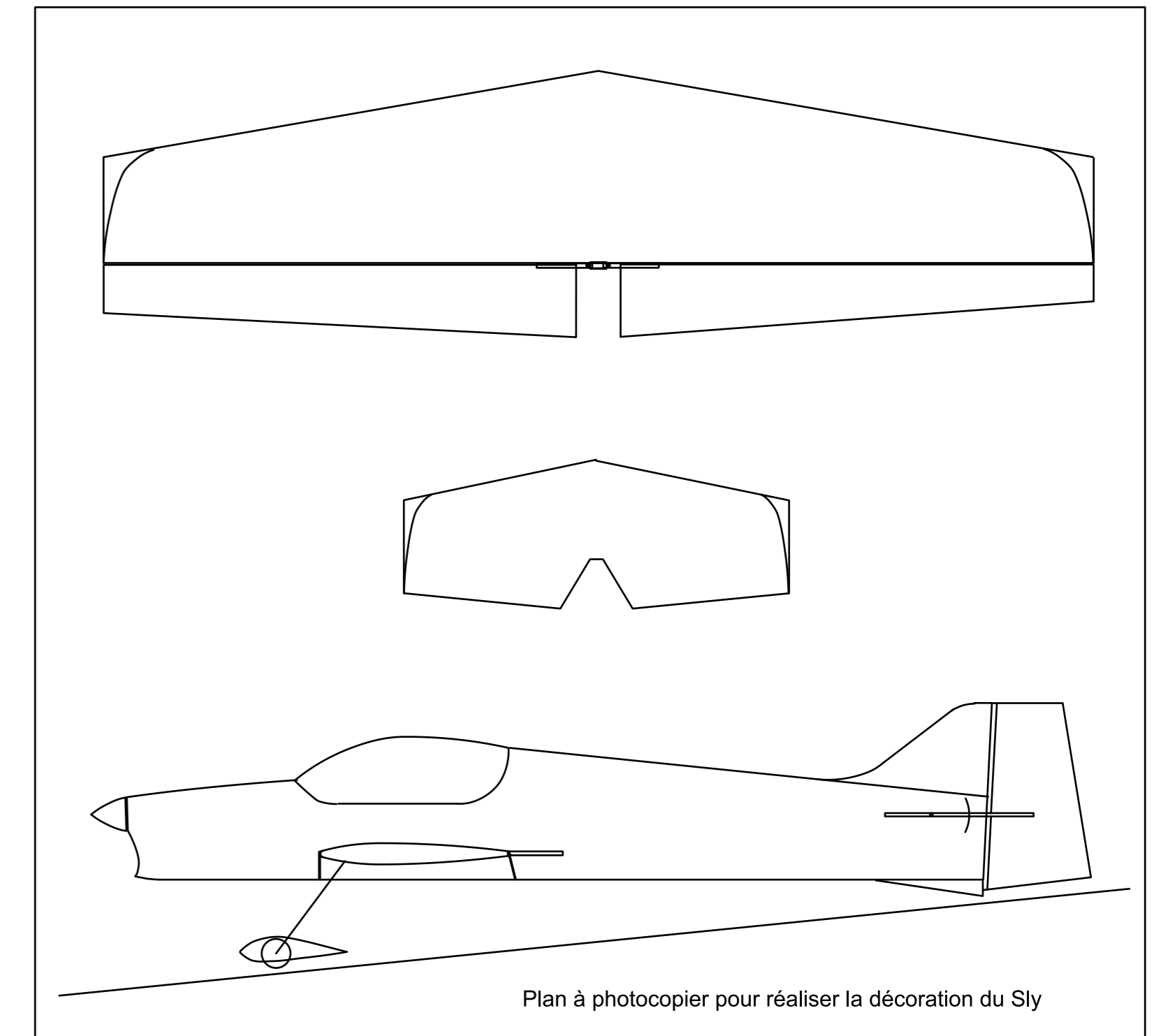

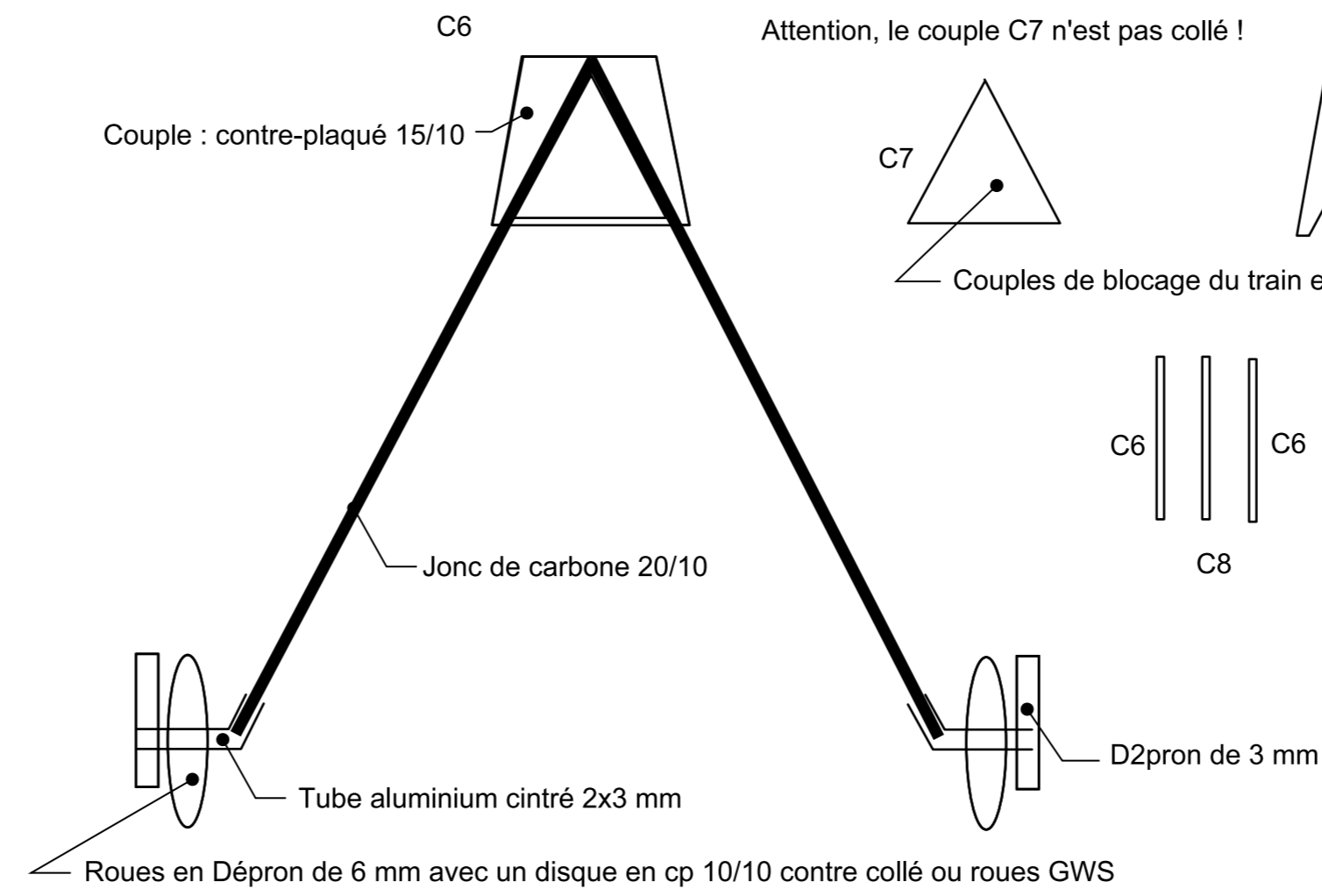
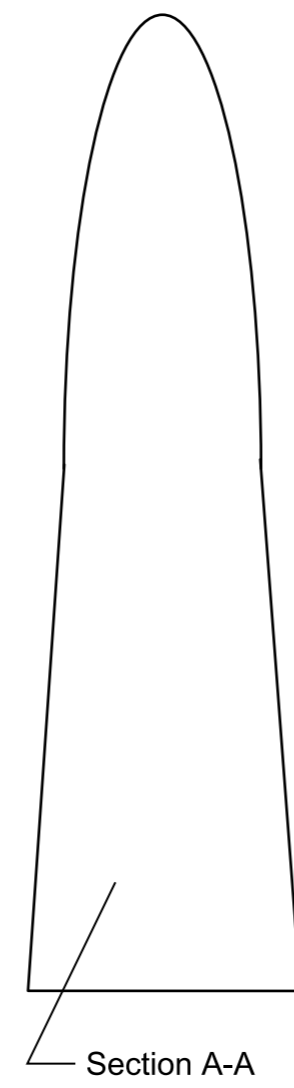
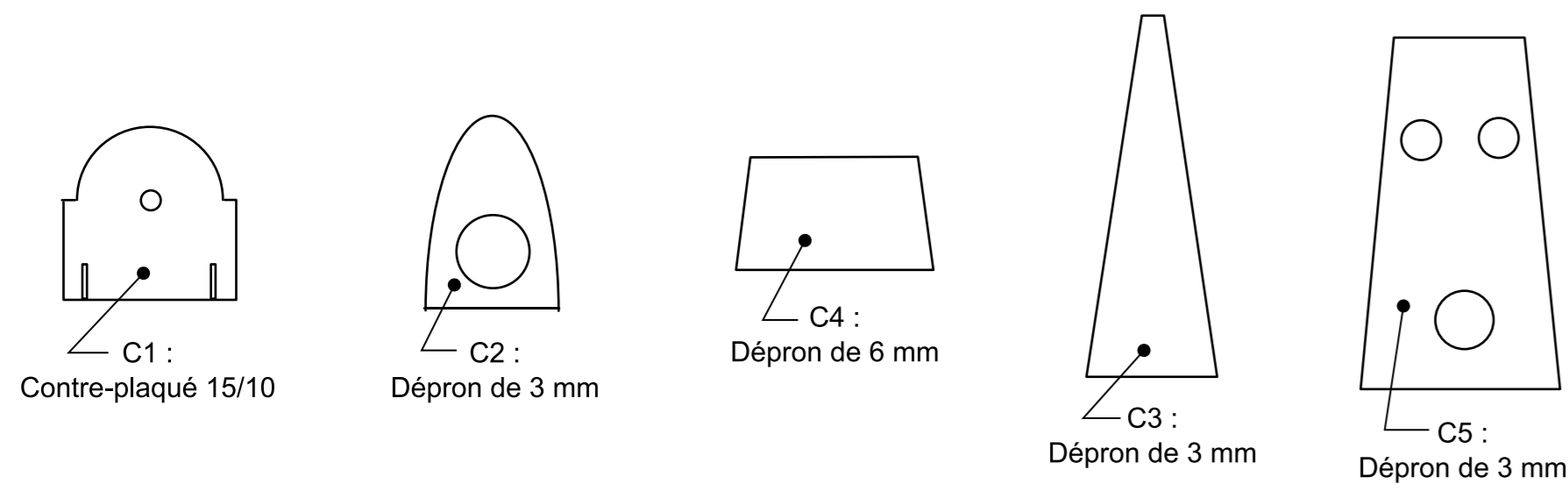

Les 3 couples C6, C7 puis C6 à nouveau sont contre collés

GWS Pico
 Les servos sont des GWS ou équivalent de 4 à 6 g

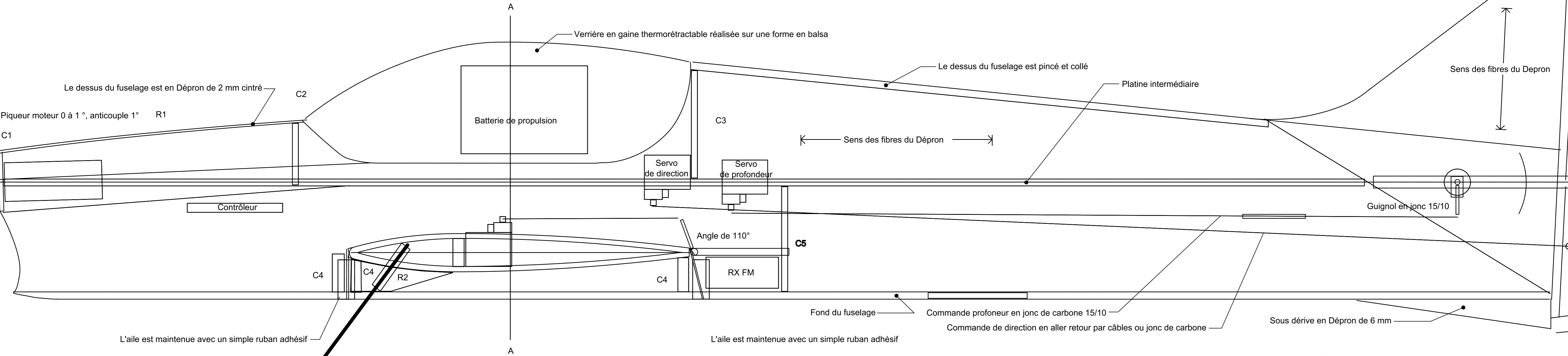
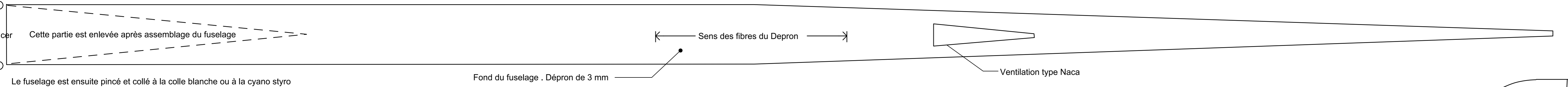
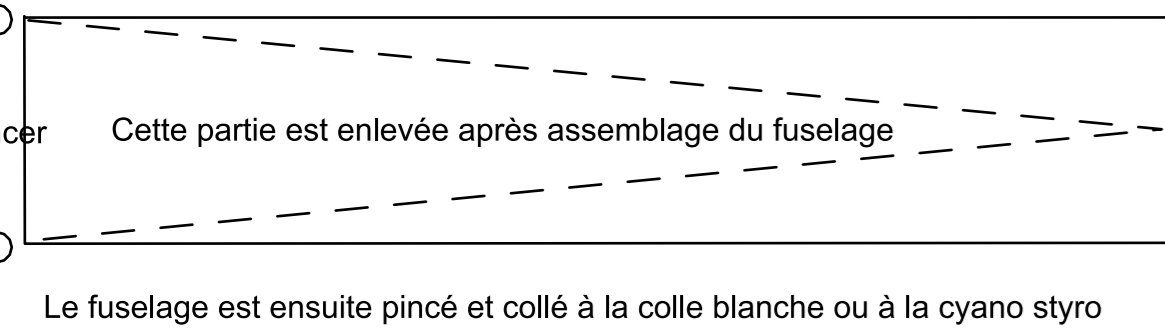
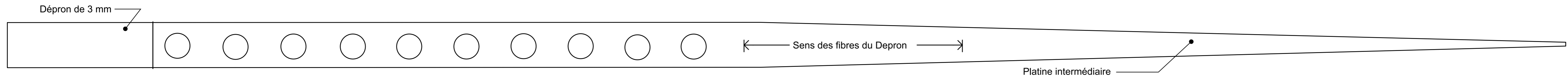
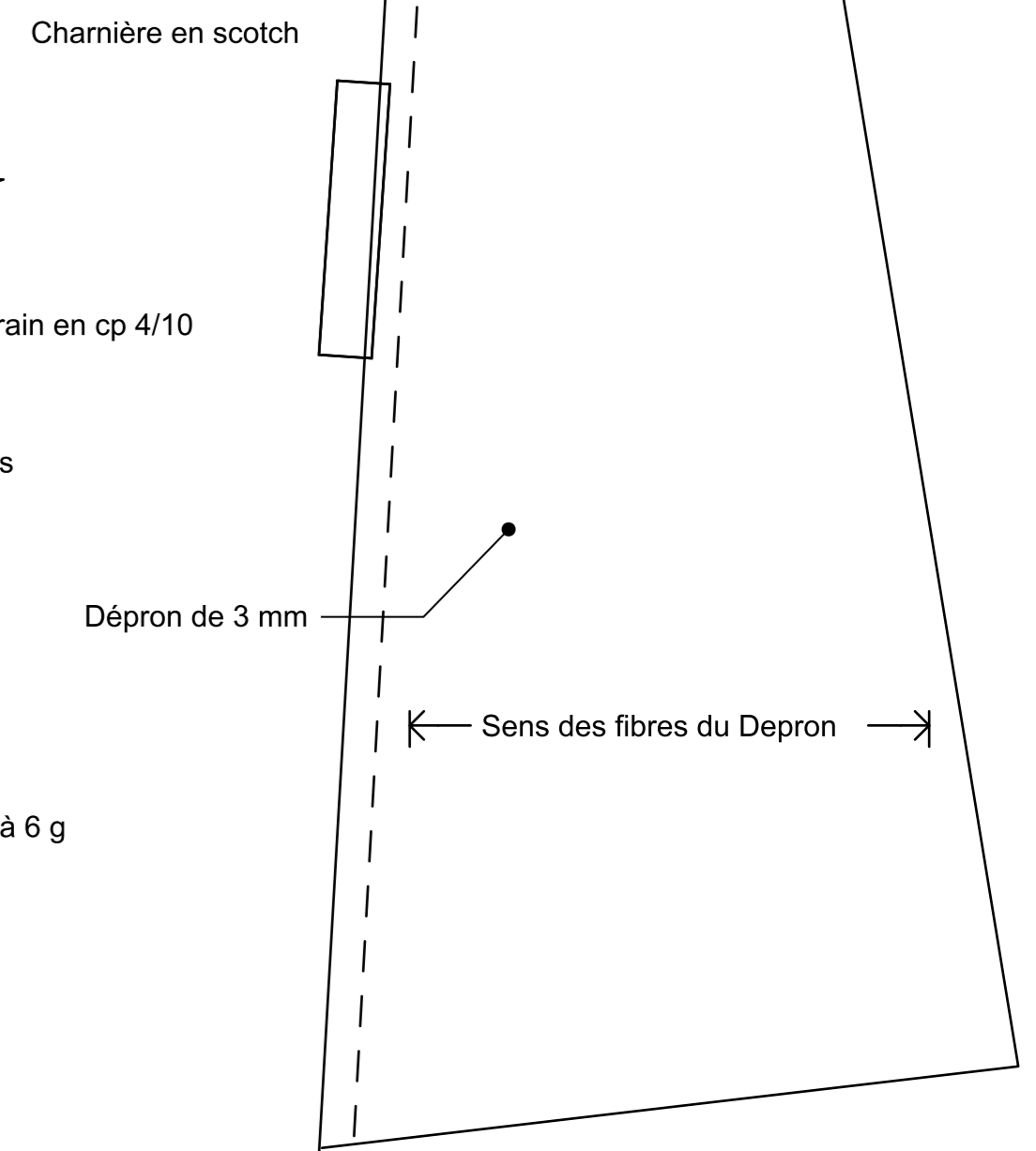

SLY
 Conception / dessin : Pascal Delannoy (Mai 2004)

Envergure : 90 cm Longueur : 90 cm Poids : 230 à 290 g (195 g avec un équipement light) Surface : 17 dm ² Charge alaire : 14 à 17 g/dm ² (11 g/dm ² avec un équipement light)	Equipements : Motorisation : Hacker B26S réduite 4/1 ou même classe de puissance type LRK Hélice : 9"x6" et 10"x4,7" APC SF ou GWS Accus : Lipo Kokam HD 350 7,4 V et 1200 ou E-Tec 1200 11,1 V Servos : 4 à 6 g GWS ou équivalent
--	--

SLY

Conception / dessin : Pascal Delannoy (Mai 2004)

Envergure : 90 cm
Longueur : 90 cm
Poids : 230 à 290 g
(195 g avec un équipement light)
Surface : 17 dm²
Charge alaire : 14 à 17 g/dm²
(11 g/dm² avec un équipement light)

Equipements :
Motorisation : Hacker B26S réductée 4/1
ou même classe de puissance type LRK
Hélice : 9"x6" et 10"x4,7" APC SF ou GWS
Accus : Lipo Kokam HD 350 7,4 V
et 1200 ou E-Tec 1200 11,1 V
Servos : 4 à 6 g GWS ou équivalent

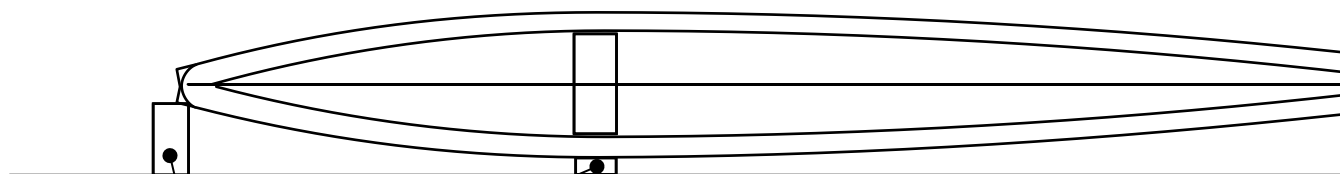
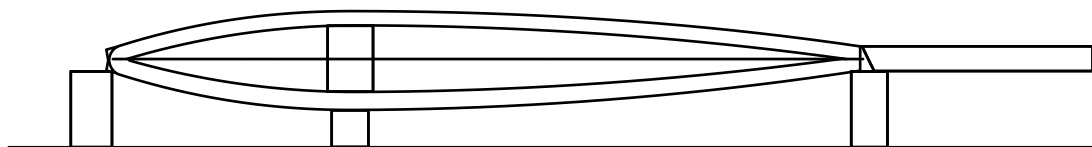

← Cale Triangulaire 2x6 à l'emplanture à 5x6 au saumon sur 480 mm d

← Cales en Dépron de 6 mm maintenues au scotch double face sur le cha



Dépron de 6 mm

← Sens des fibres du Depron →

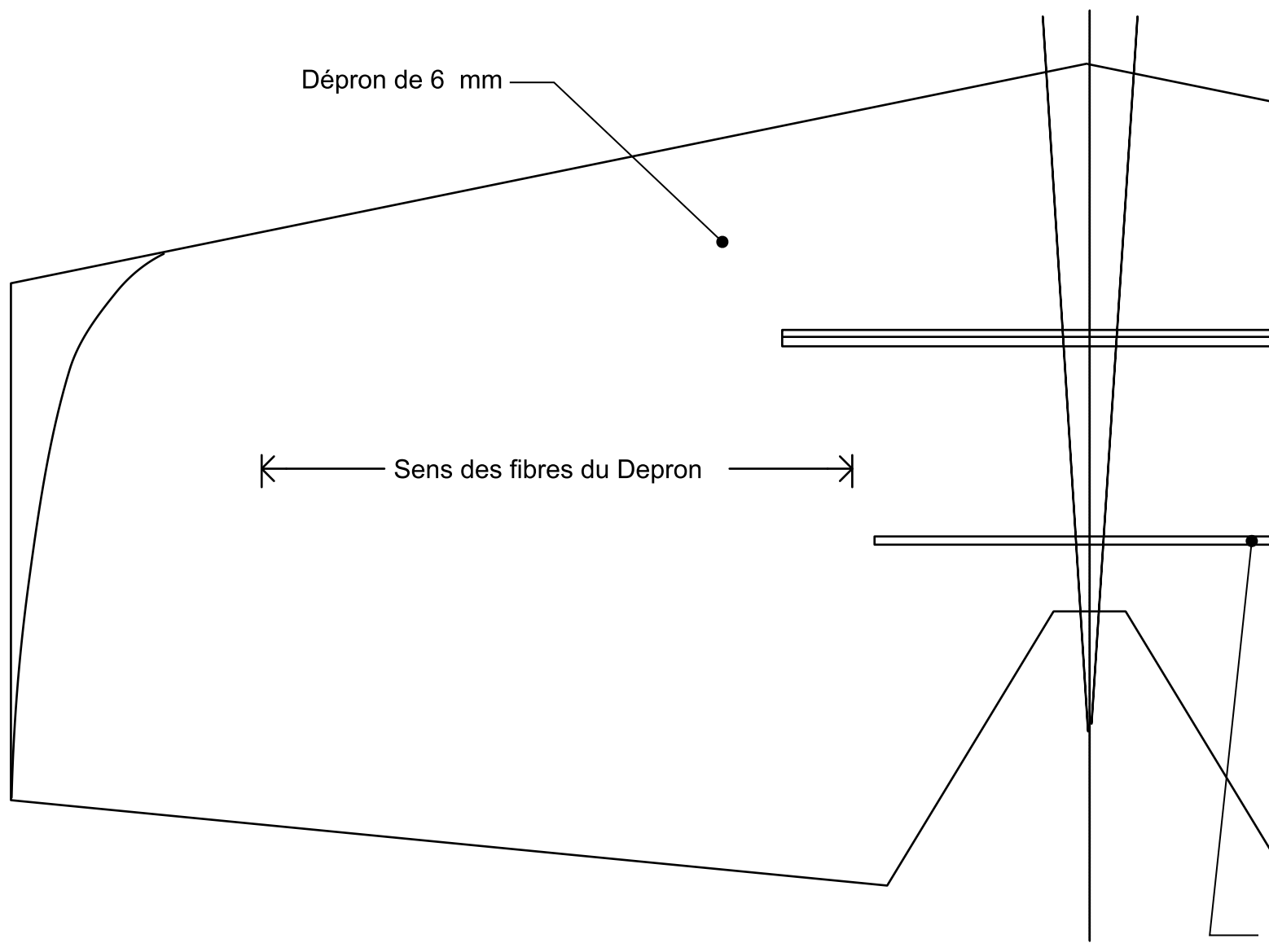

Le stabilisateur entier est découpé

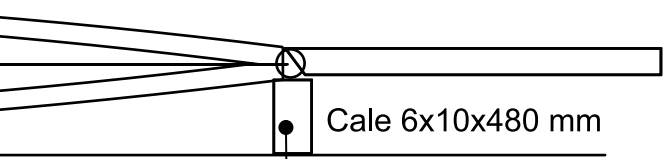

Cale 6x10x480 mm

480 mm de long

sur le chantier

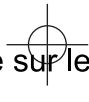

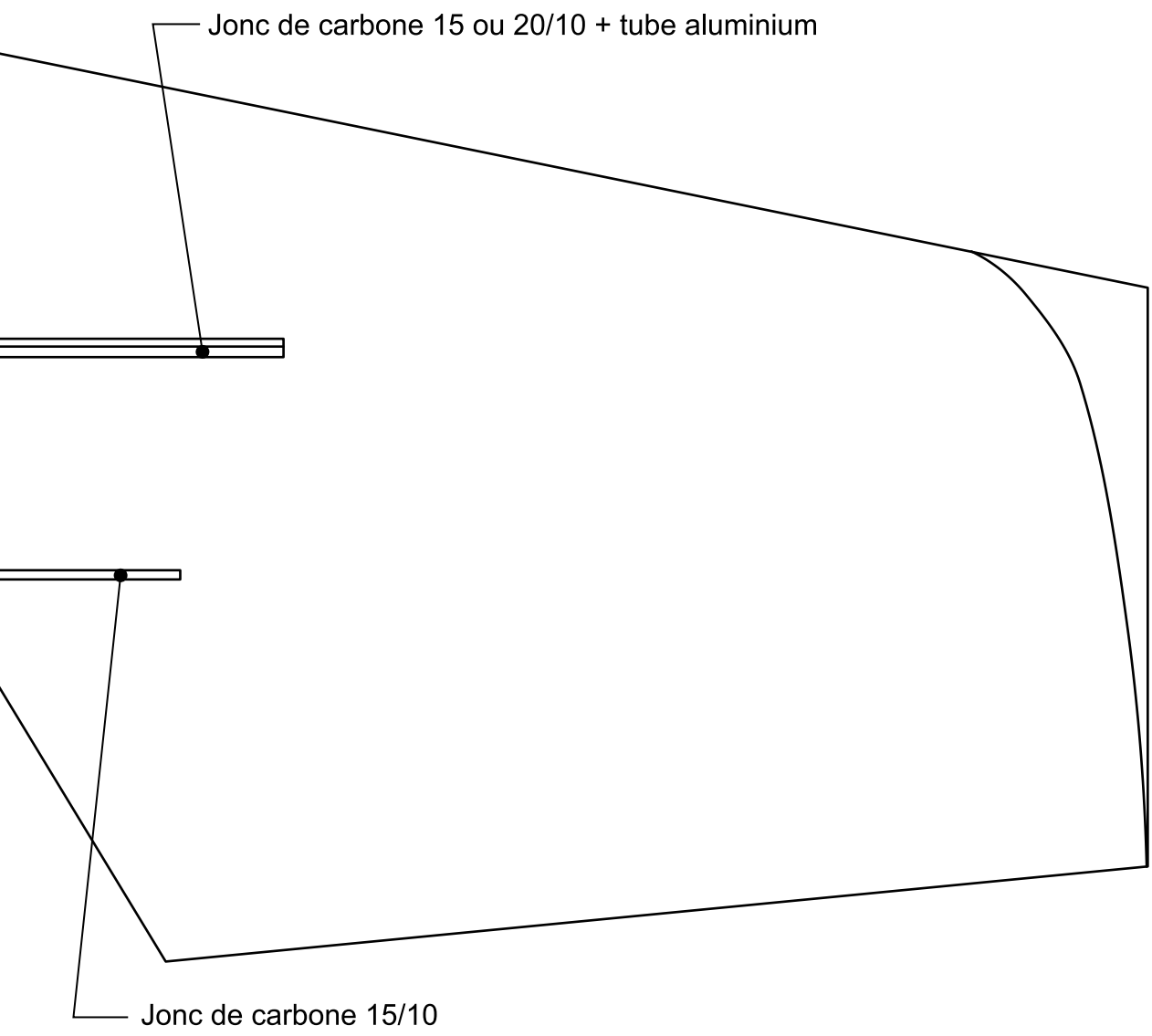

est découpé puis après collage des tubes aluminium il est coupé en 2 pièces

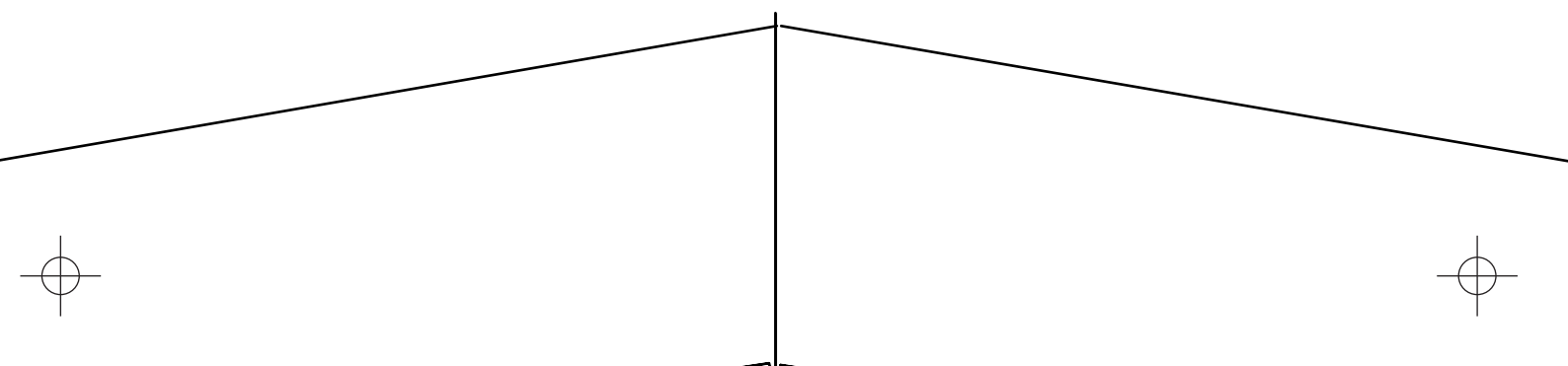

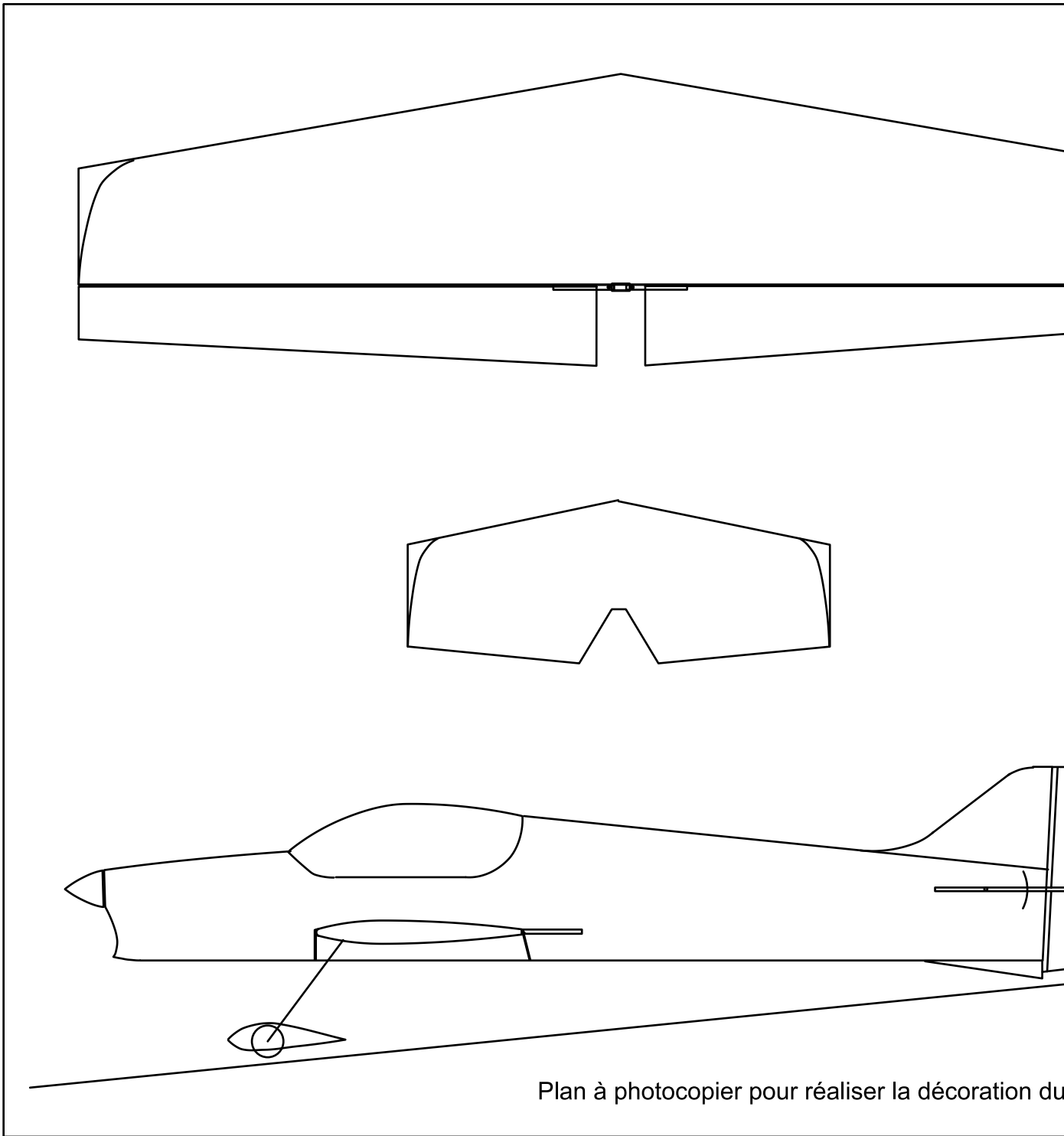

Plan à photocopier pour réaliser la décoration du

L'aile est réalisée en une pièce





— Cales en Dépron de 6 mm maintenues au scotch double face sur le cha

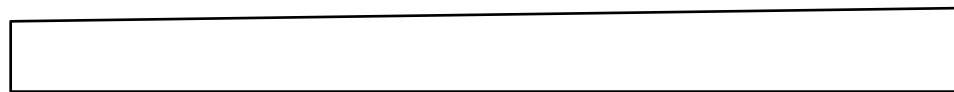
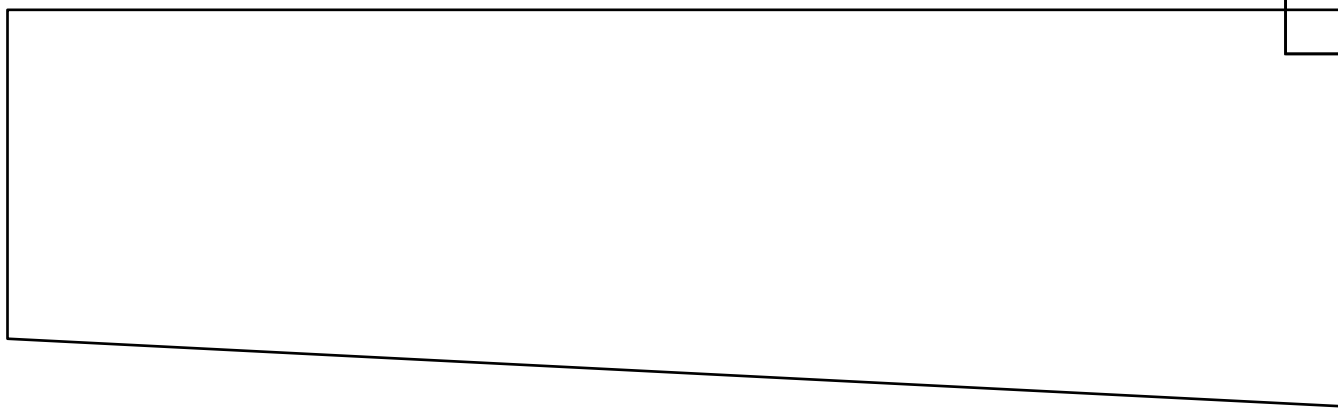
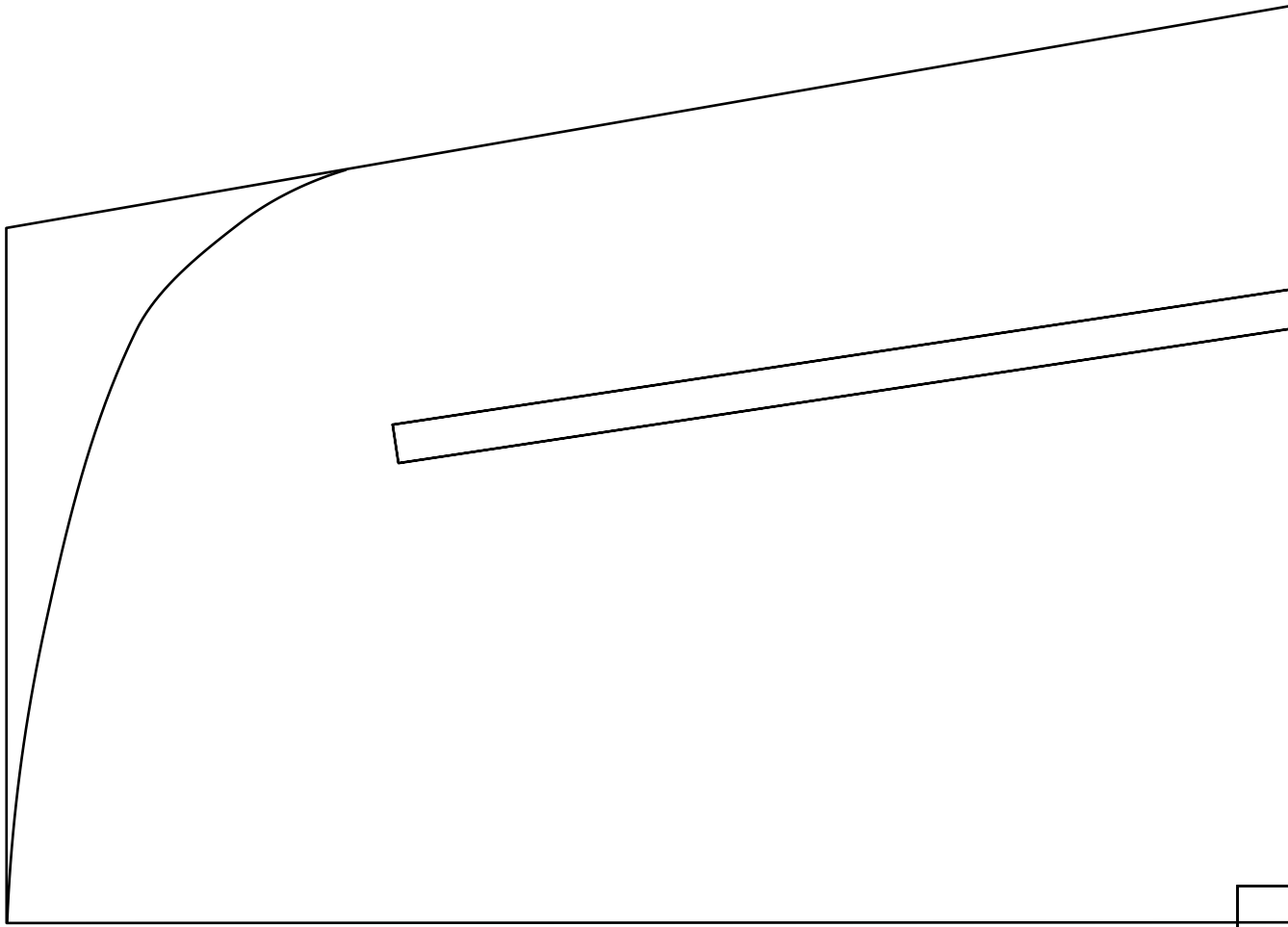

480 mm de long

e sur le chantier



← Sens des fibres du Dépron →

Dépron de 3 mm

Charnières en scotch transparent de bureau ou Blendherm

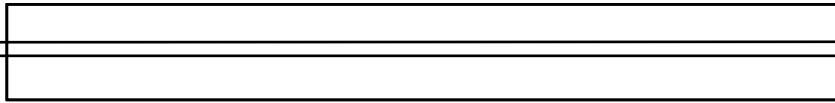

← Sens des fibres du Dépron →

Dépron de 3 mm

Longerons en Dépron de 6 mm

← Sens des fibres du Depron →



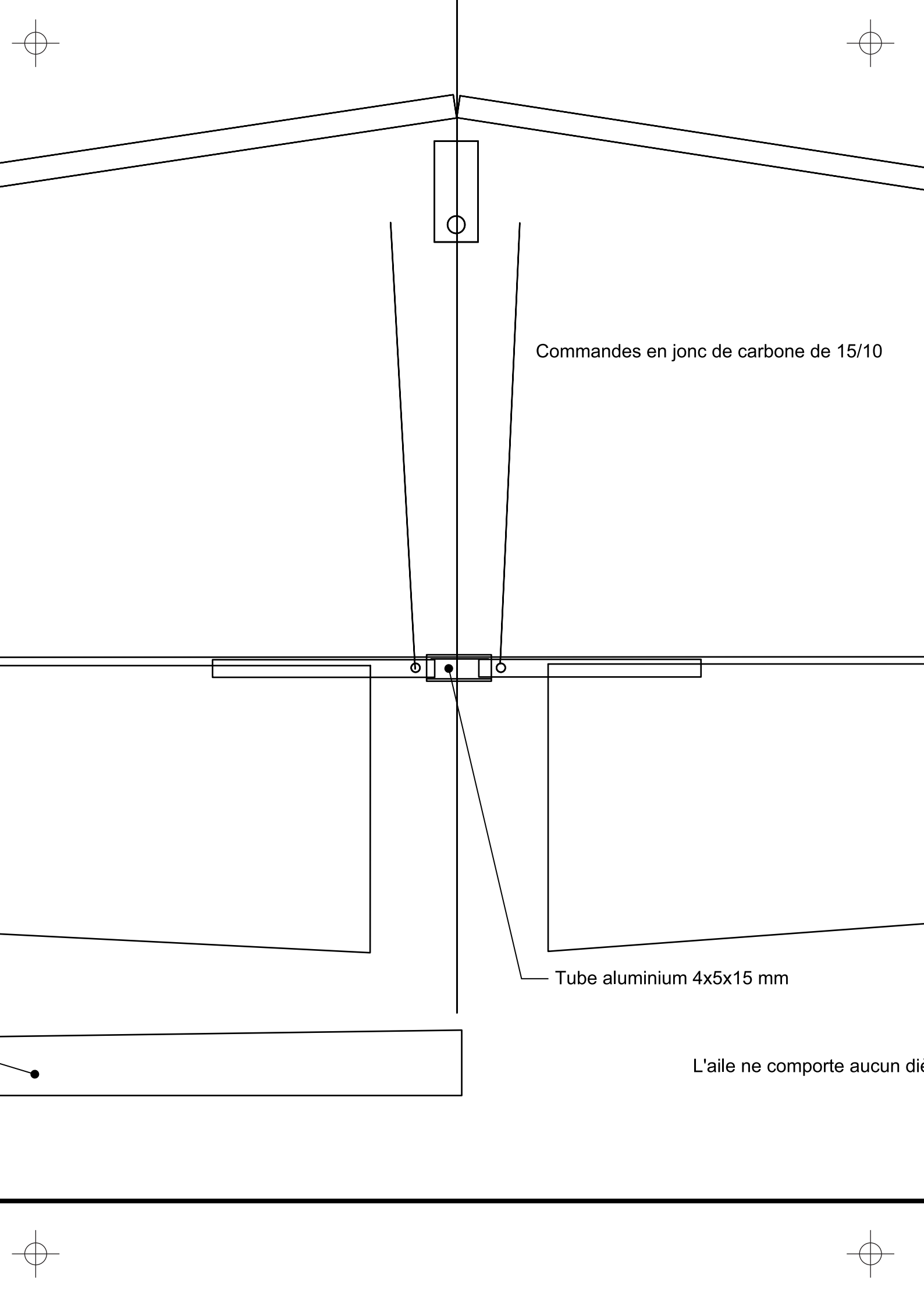

Commandes en jonc de carbone de 15/10

Tube aluminium 4x5x15 mm

L'aile ne comporte aucun dia



15/10

e aucun dièdre



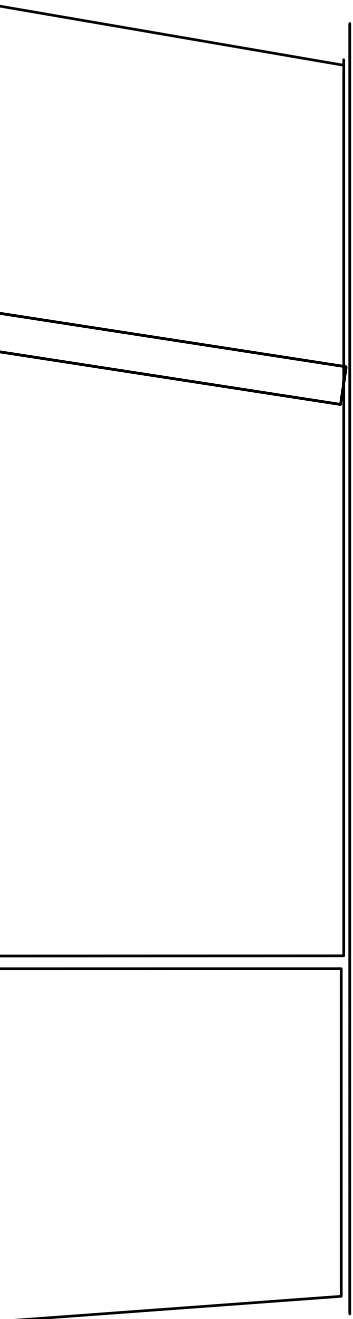

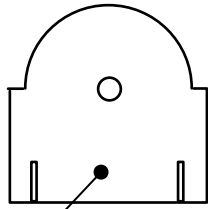

C1 :
Contre-plaqué 15/10

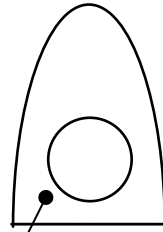

C2 :
Dépron de 3 mm

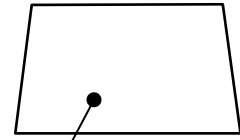

C4 :
Dépron de 6 mm



Dépron



R1 : Contre-plaqué 4/10

Dépron de 3 mm

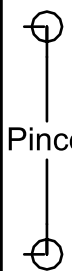
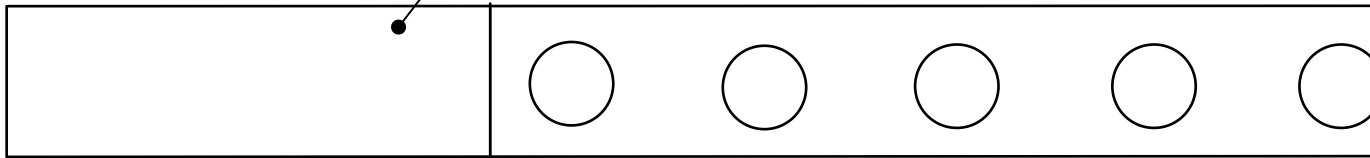

Pincer

Cette partie est enlevée après assemblage du fuselage

Le fuselage est ensuite pincé et collé à la colle blanche ou à la cyano styro



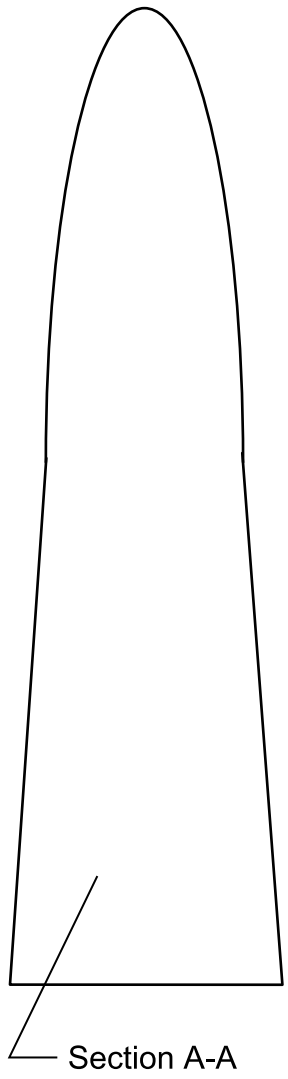
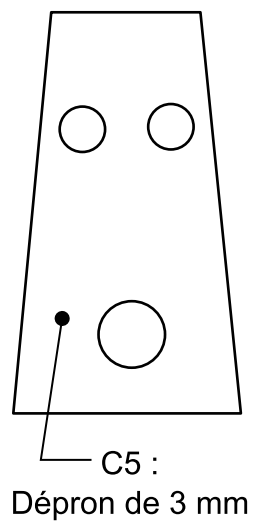
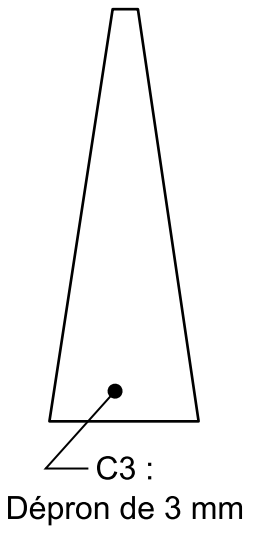

Couple : contre-

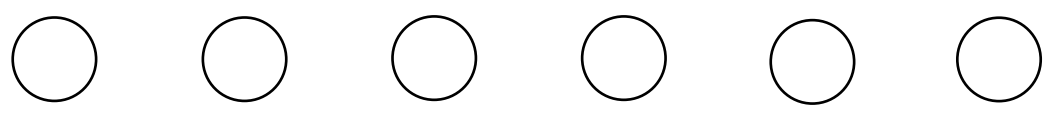
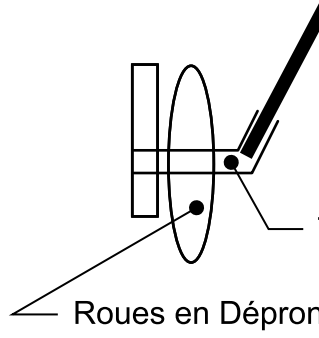

← Sens des fibres

← Sens des fibres

Fond du fuselage . Dépron de 3 mm



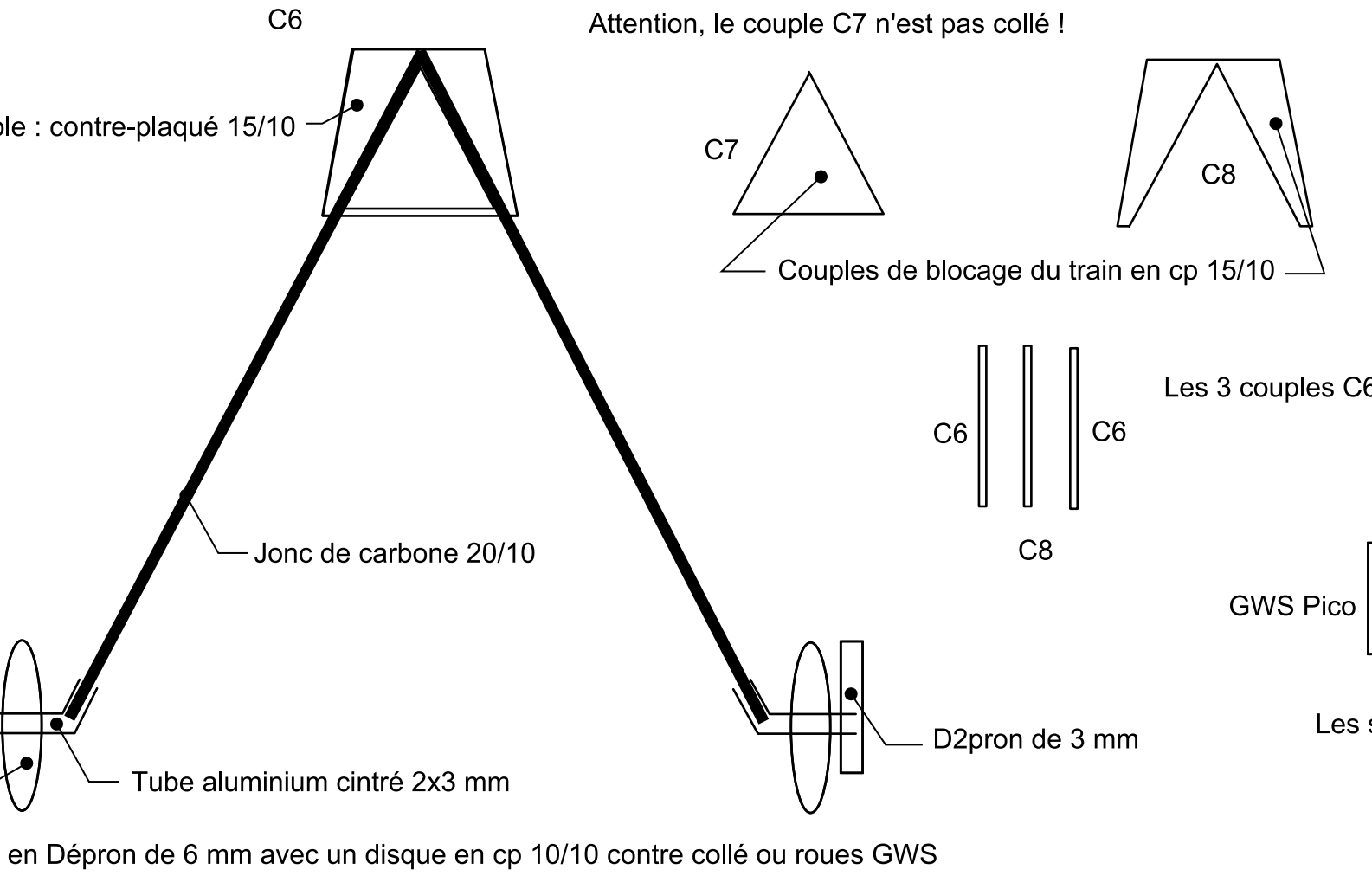

ns des fibres du Depron →

Platine intermédiaire

ns des fibres du Depron →

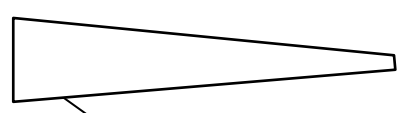

Ventilation type Naca



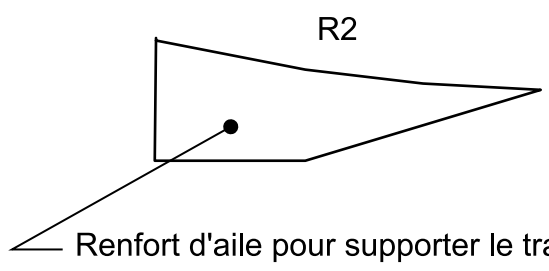
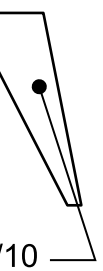

Renfort d'aile pour supporter le train en cp 4/10

Charnière en scotch

couples C6, C7 puis C6 à nouveau sont contre collés

GWS Pico

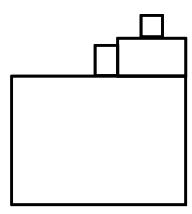

Les servos sont des GWS ou équivalent de 4 à 6 g

Dépron de 3 mm

← Sens des fibres du Dépron

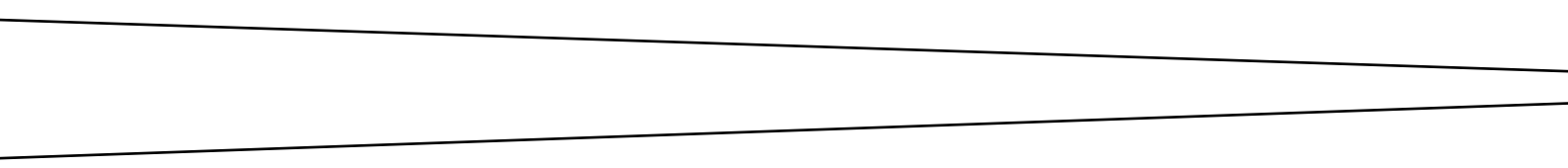
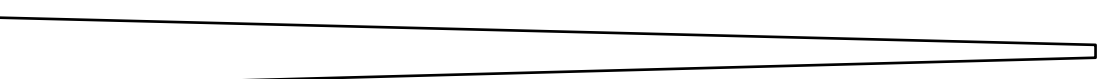
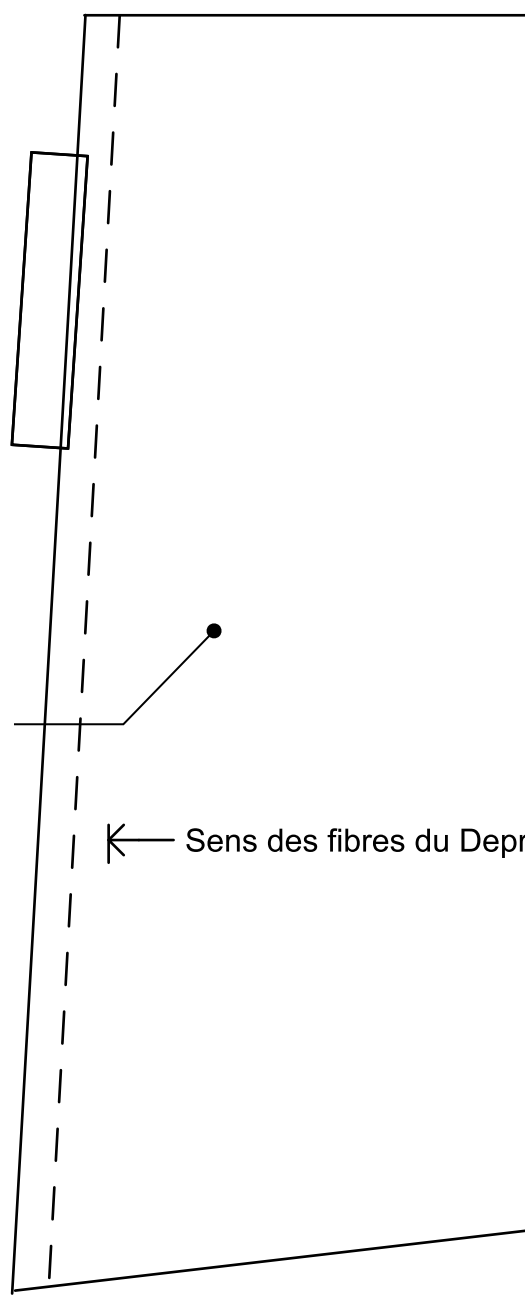

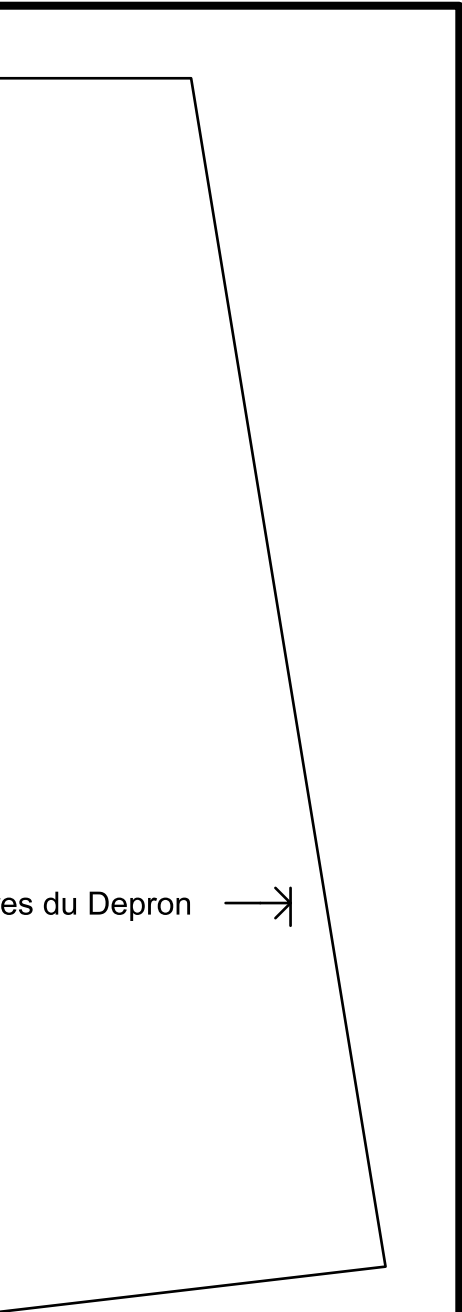

es du Depron →

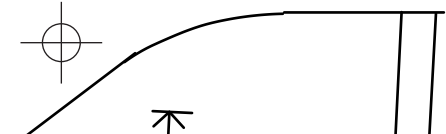
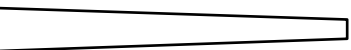

Le fuselage est ensuite pincé et collé à la colle blanche ou à la cyano styro

Le dessus du fuselage est en Dépron de 2 mm cintré

Piqueur moteur 0 à 1°, anticouple 1° R1

C1

C2

Contrôleur

C4

L'aile est maintenue avec un simple ruban adhésif

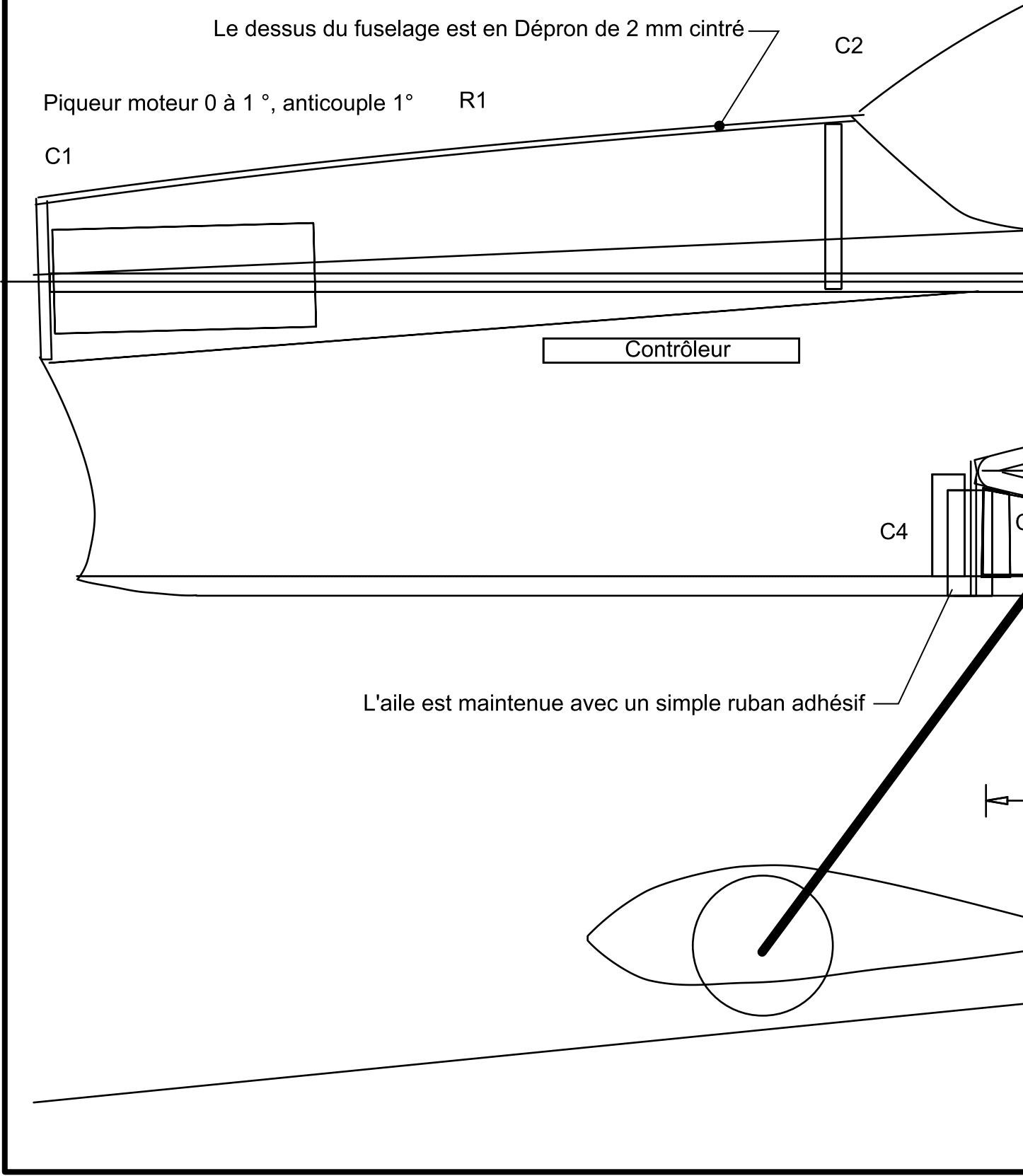

Fond du fuselage . Dépron de 3 mm

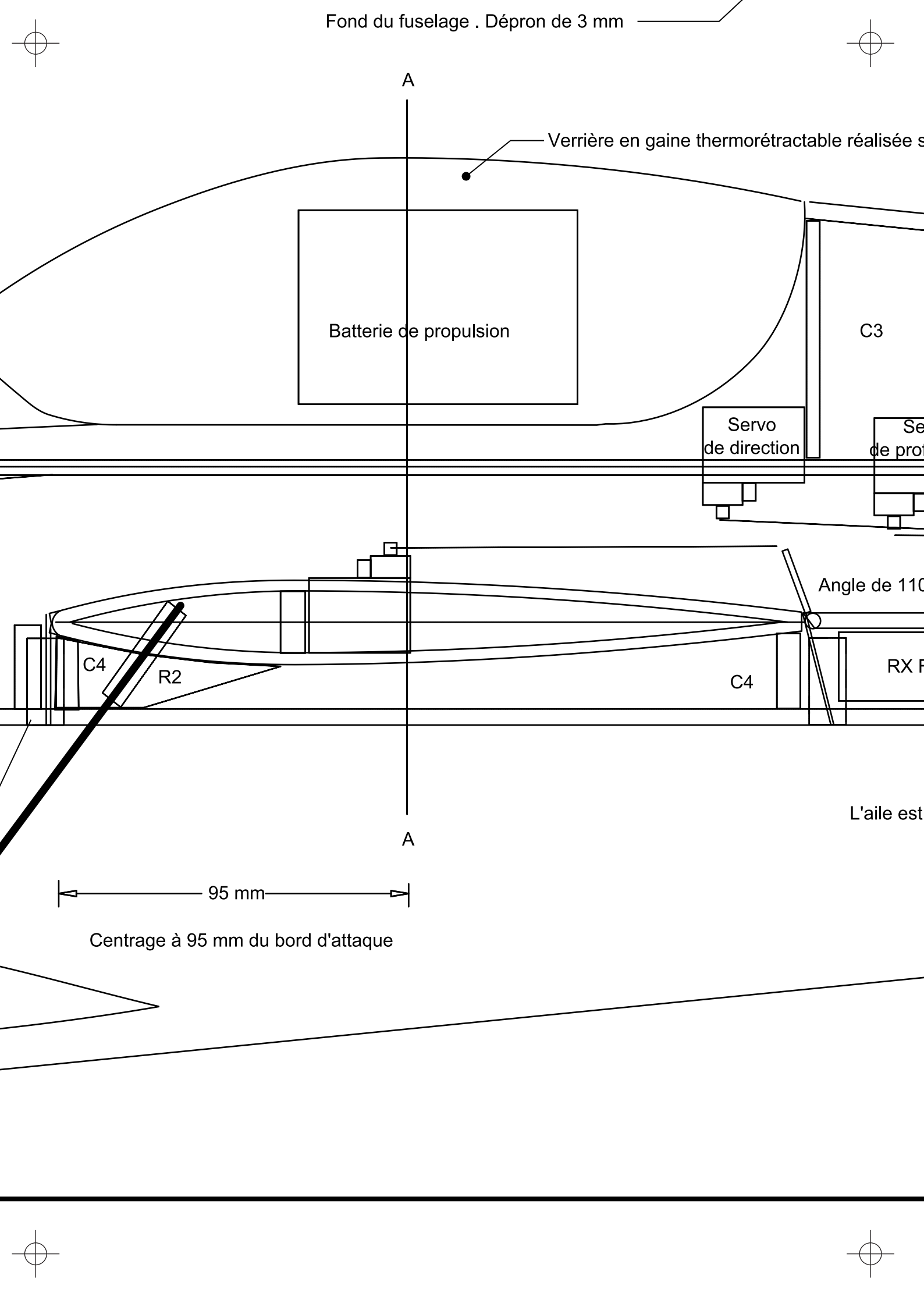

Verrière en gaine thermorétractable réalisée s...

Batterie de propulsion

C3

Servo de direction

Se de pro

Angle de 110°

C4

R2

C4

RX F

L'aile est

95 mm

Centrage à 95 mm du bord d'attaque

réalisée sur une forme en balsa

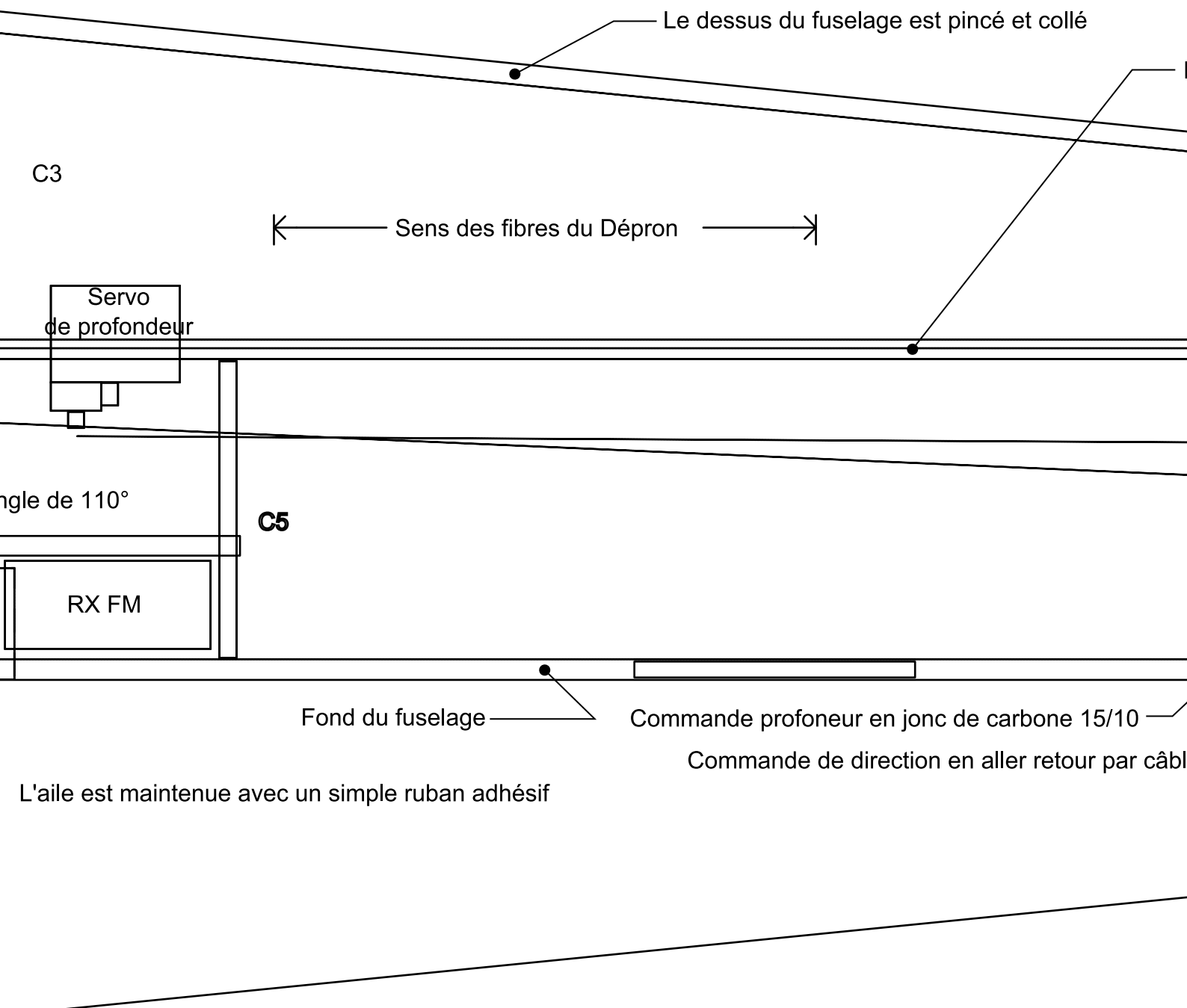

L'aile est maintenue avec un simple ruban adhésif



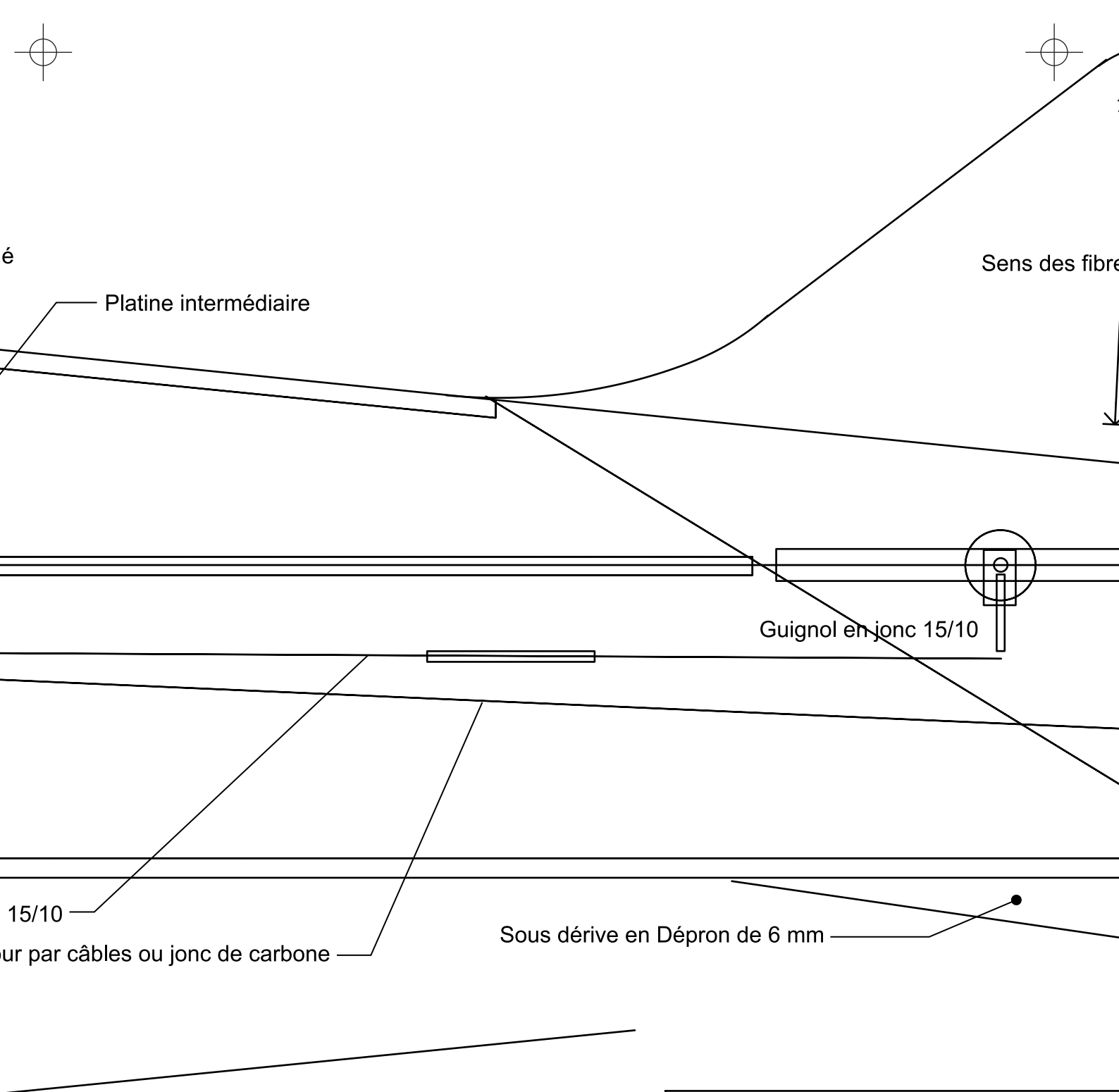

SLY

Conception / dessin : Pascal Delannoy

Envergure : 90 cm
 Longueur : 90 cm
 Poids : 230 à 290 g
 (195 g avec un équipement light)
 Surface : 17 dm²
 Charge alaire : 14 à 17 g/dm²
 (11 g/dm² avec un équipement light)

Equipements :
 Motorisation : Hacker B2
 ou même classe de puis
 Hélice : 9"x6" et 10"x4,7"
 Accus : Lipo Kokam HD
 et 1200 ou E-Tec 1200 1
 Servos : 4 à 6 g GWS ou

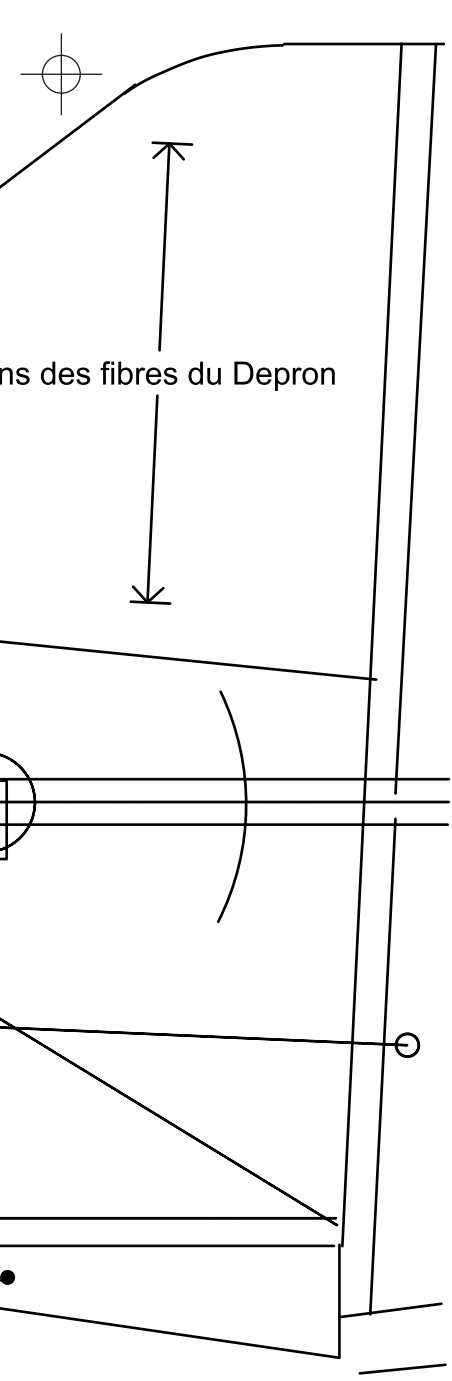

ns des fibres du Depron

Y
Delannoy (Mai 2004)
ements :
tion : Hacker B26S réduite 4/1
e classe de puissance type LRK
9"x6" et 10"x4,7" APC SF ou GWS
Lipo Kokam HD 350 7,4 V
ou E-Tec 1200 11,1 V
4 à 6 g GWS ou équivalent

