



Scale: Inches



**Foam Sheet C**  
2mm Depron Foam

Model: MX Aircraft, MXS  
Scale: 37" Wingspan  
Designer: Birger de la Peña

# MXS

37" Wingspan

Depron Construction

Birger de la Peña  
bdepen@gmail.com

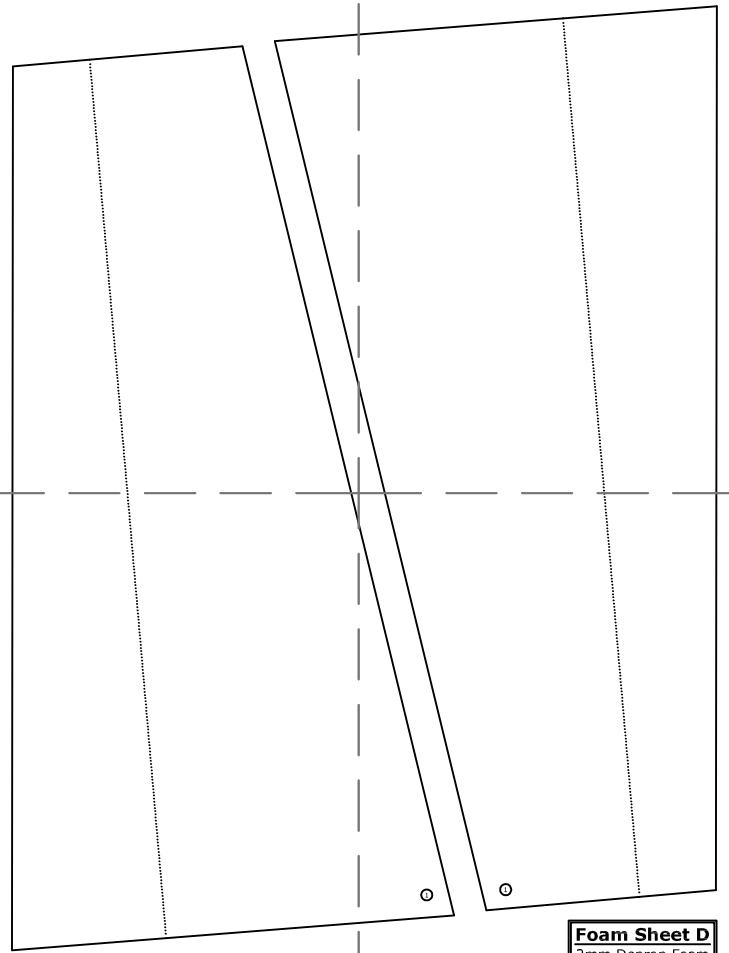
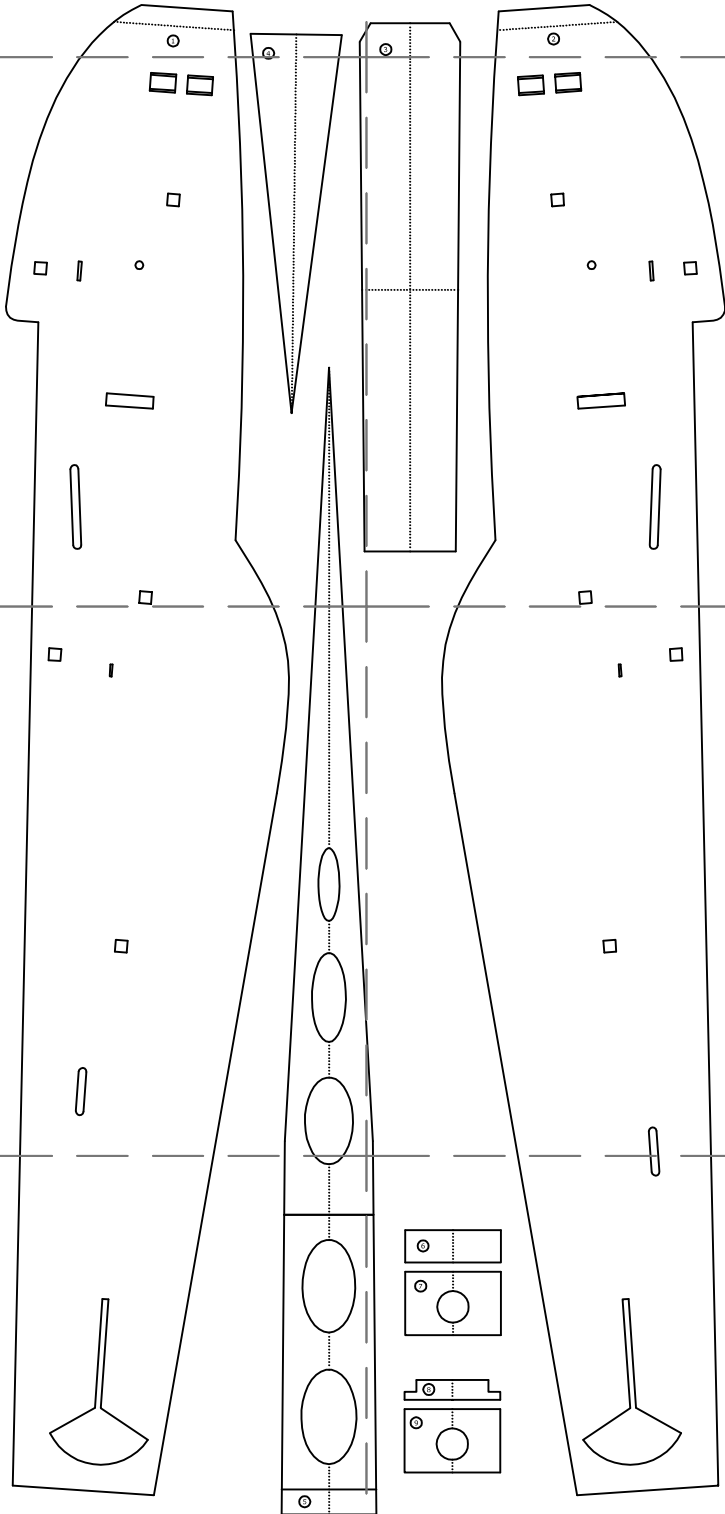

**Foam Sheet D**  
2mm Depron Foam

Model: MX Aircraft, MXS  
Scale: 37" Wingspan  
Designer: Birger de la Peña

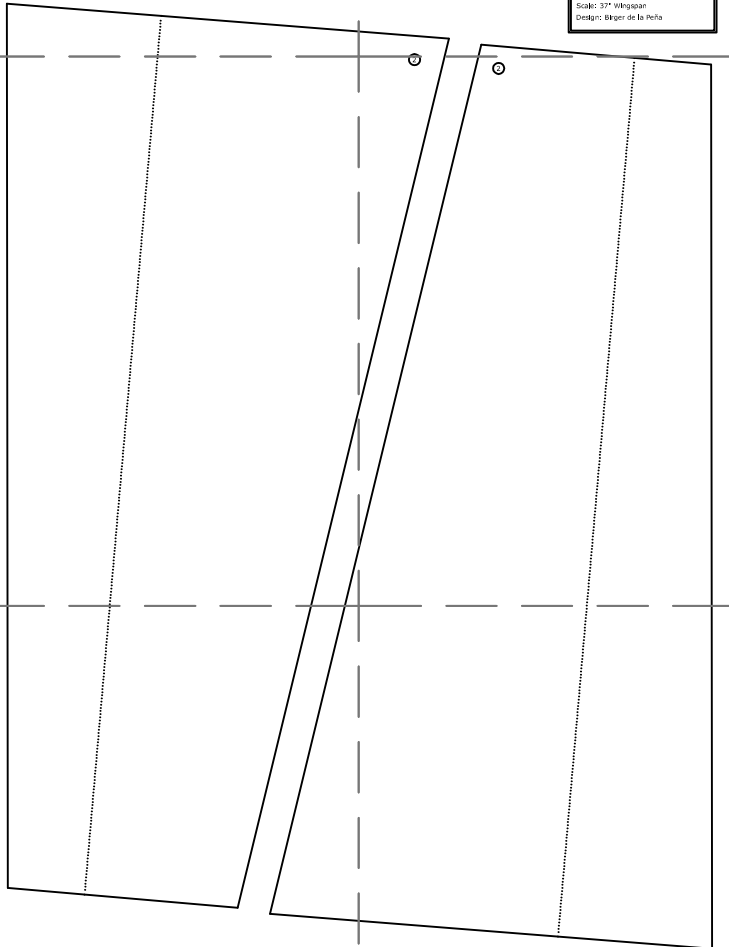

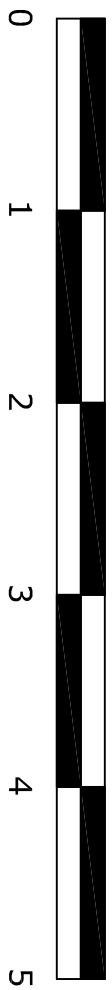

Scale: Inches

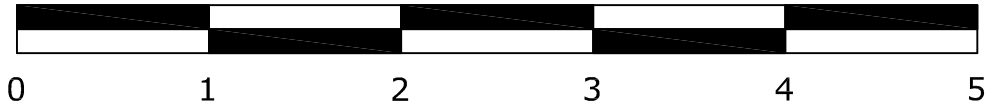

# Foam Sheet C

## 2mm Depron Foam

Model: MX Aircraft, MXS

Scale: 37" Wingspan

Design: Birger de la Peña

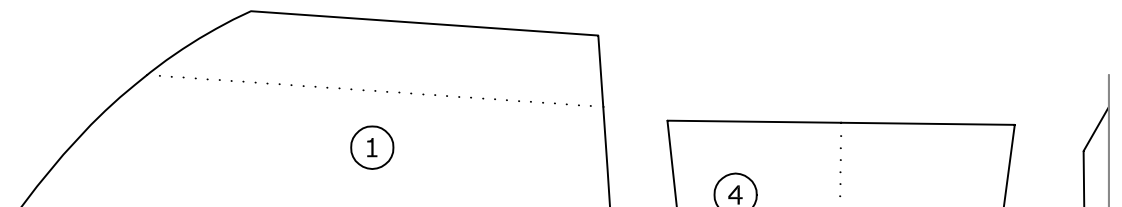

# MXS

37" Wingspan

Depron Construction

Birger de la Peña  
bdelapen@gmail.com

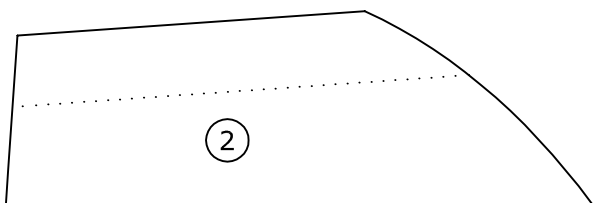
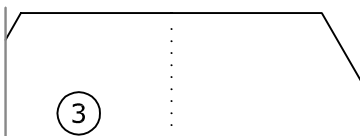

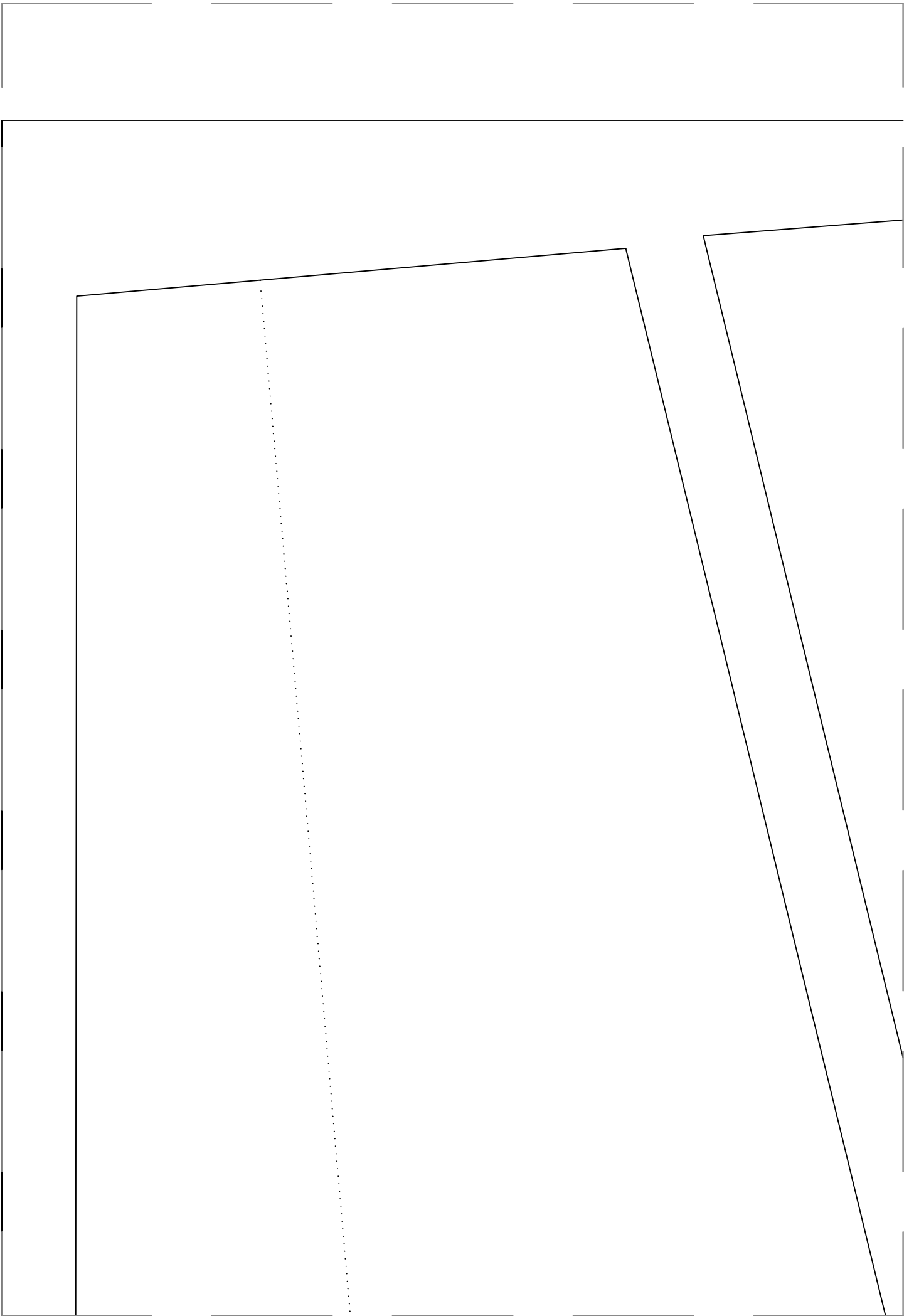

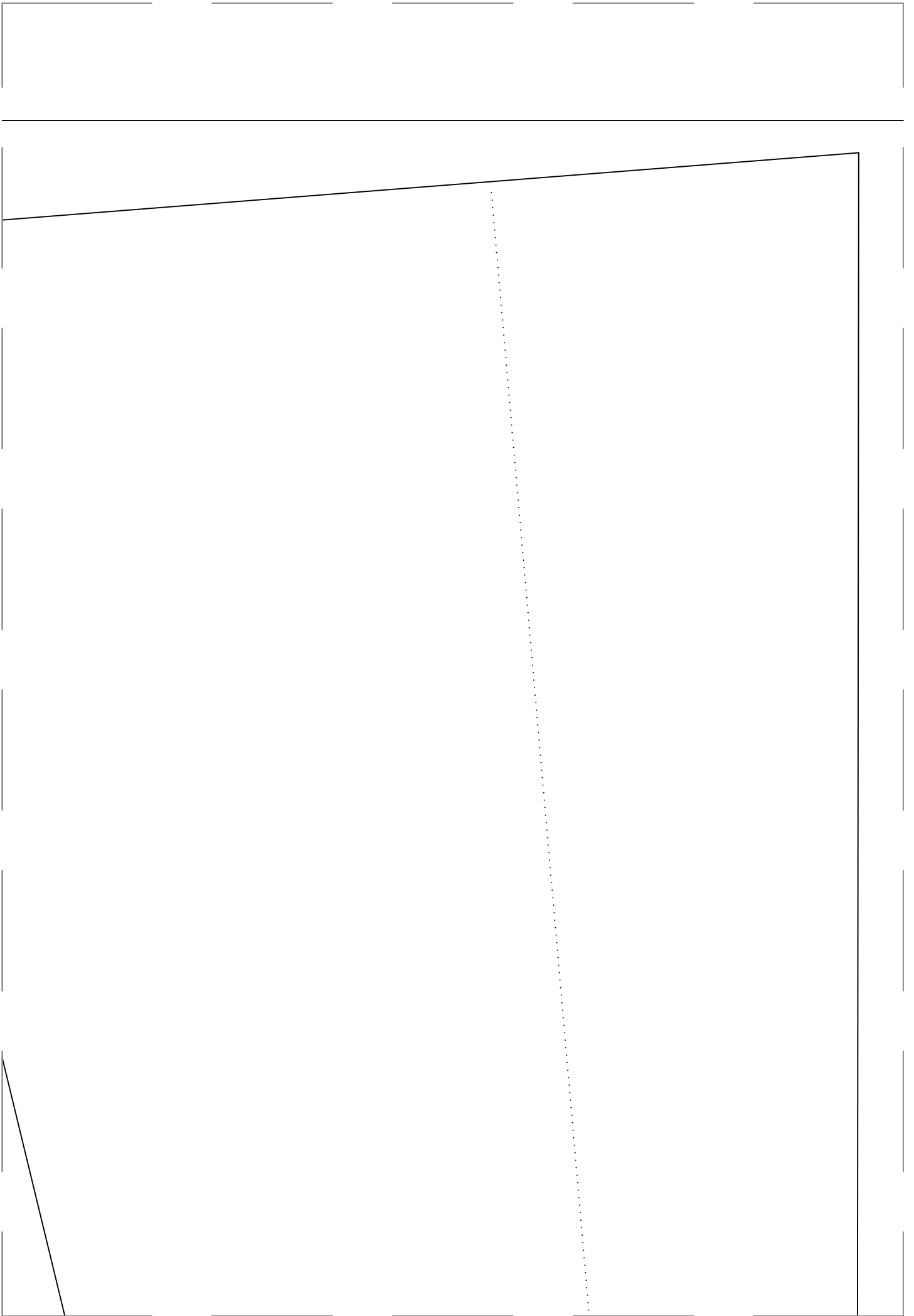

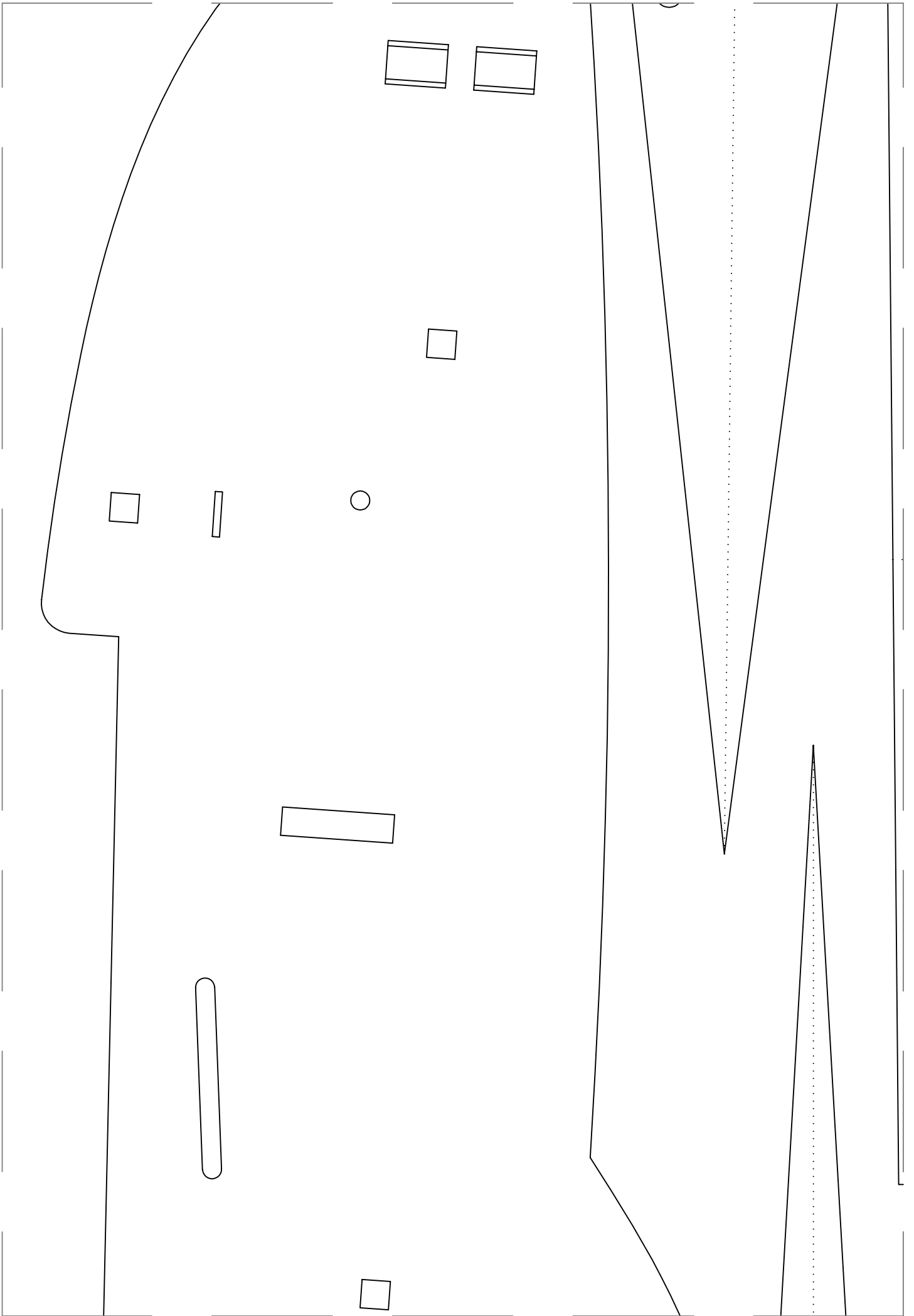

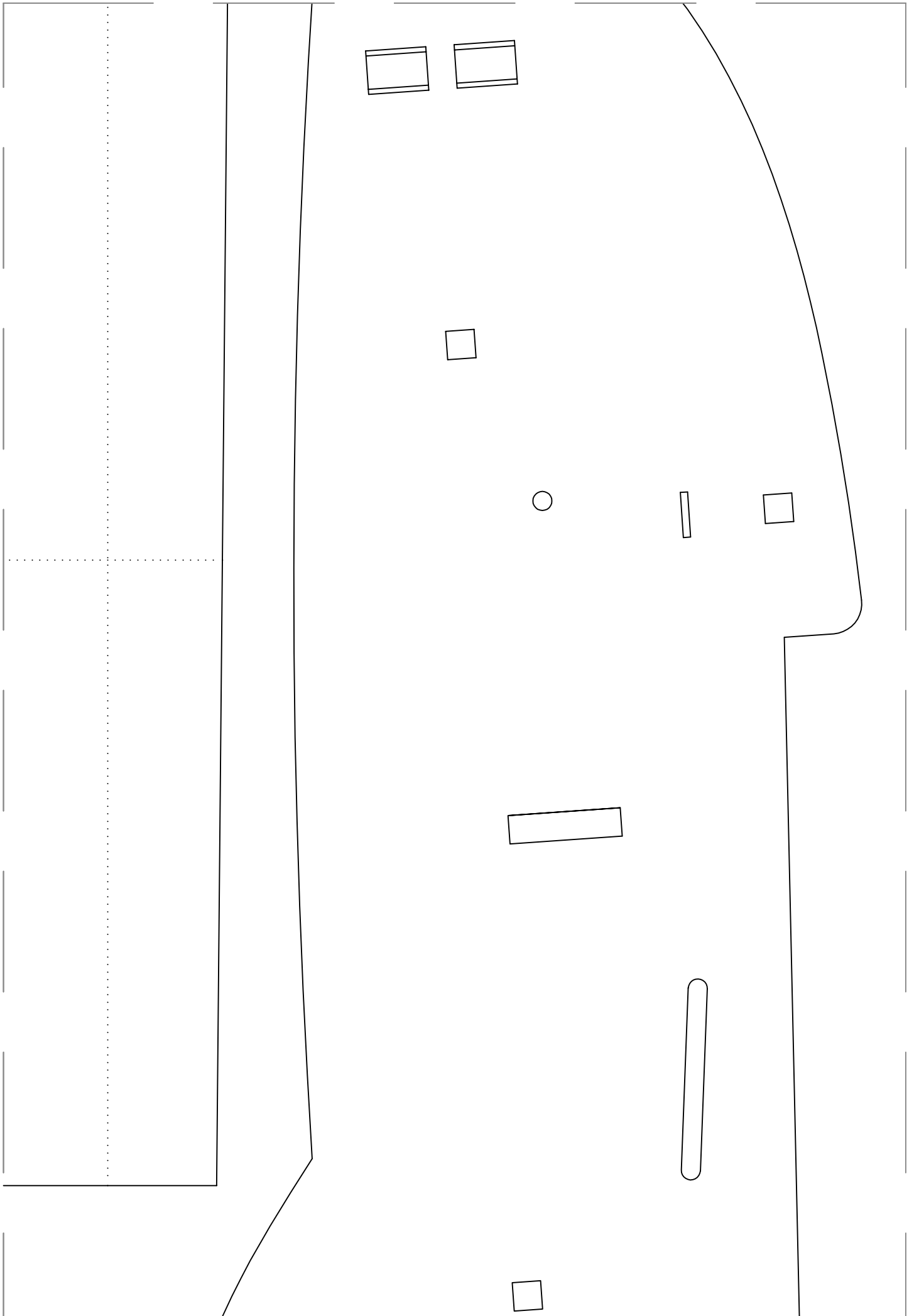

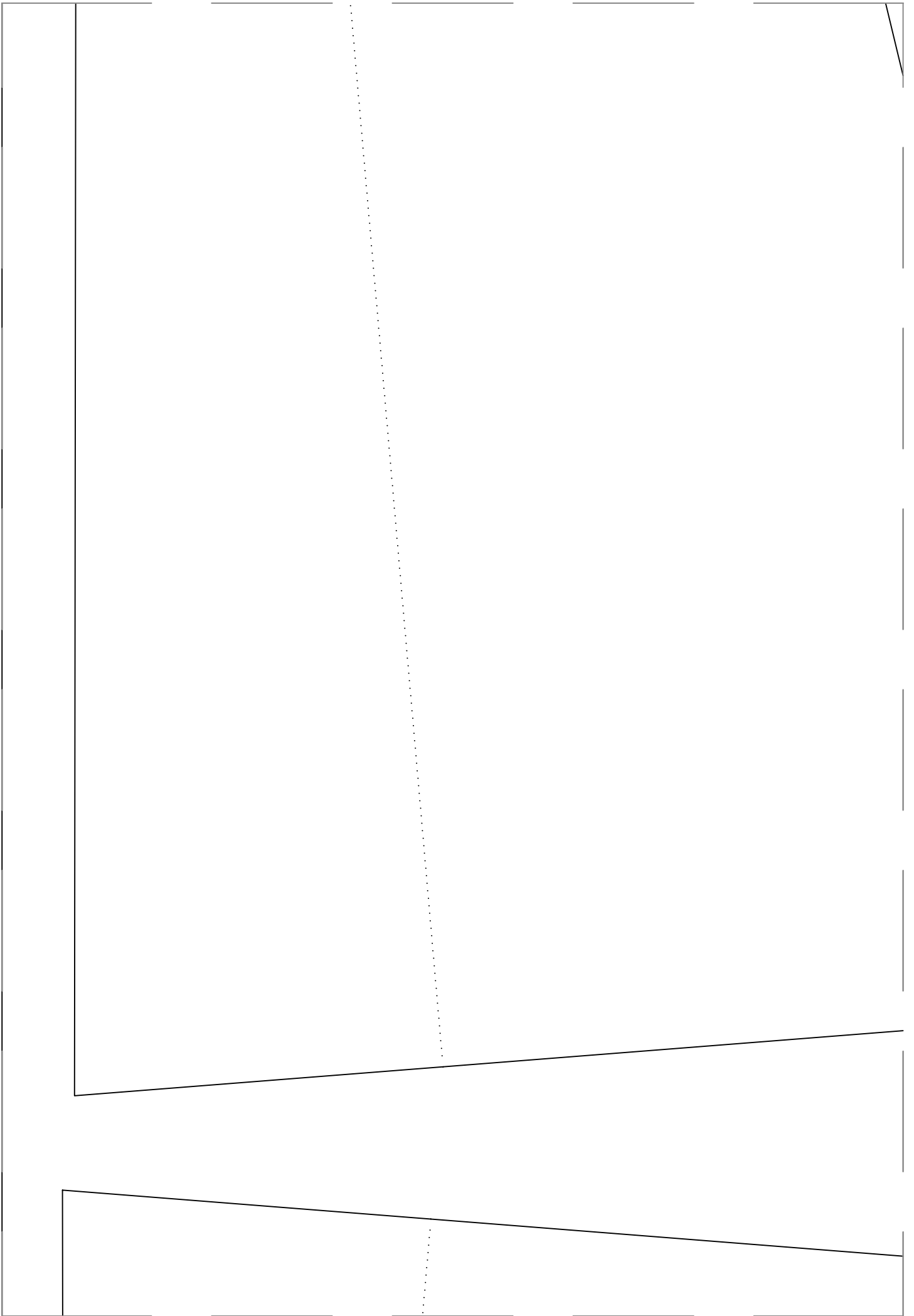

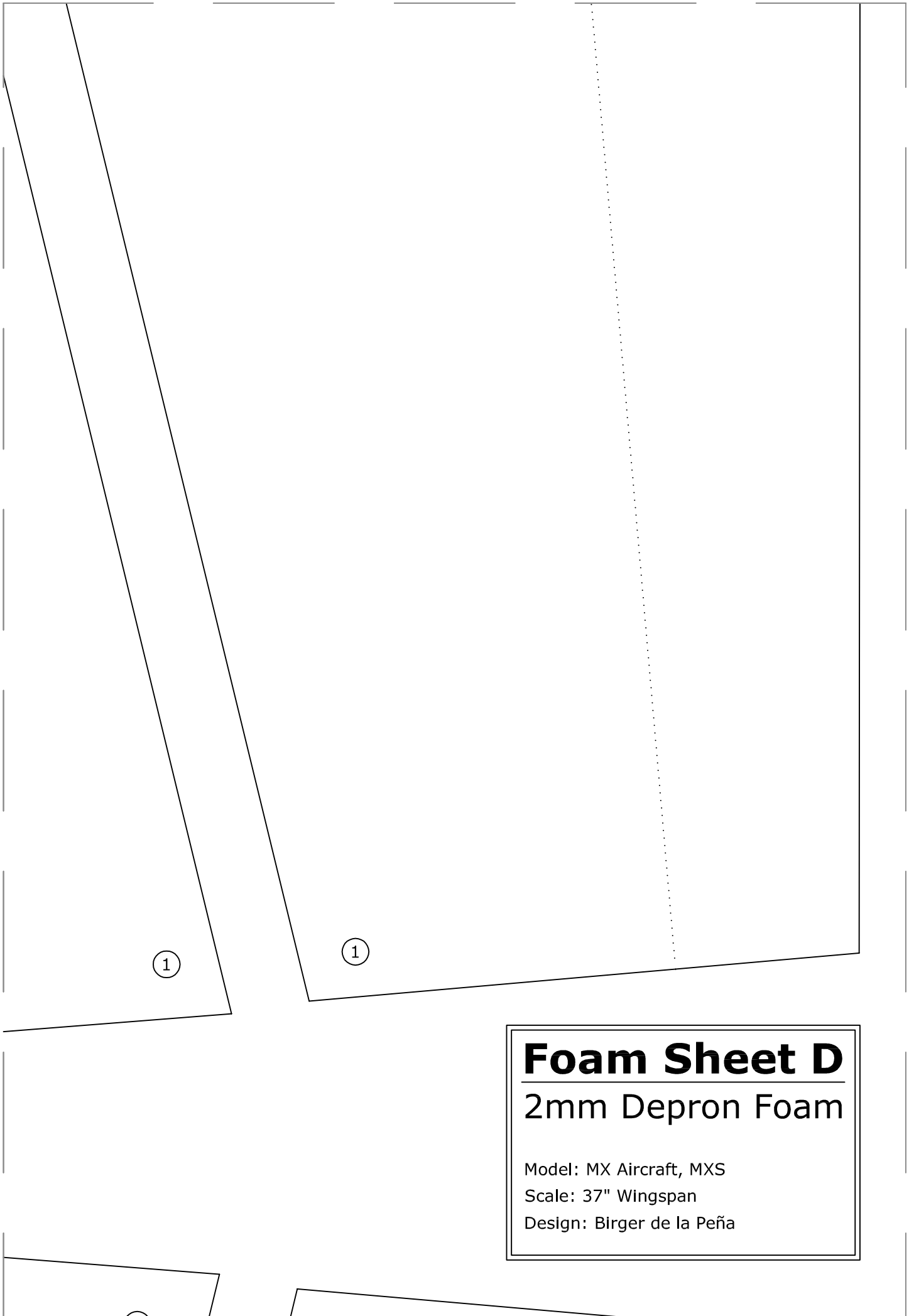

1

1

# Foam Sheet D

## 2mm Depron Foam

Model: MX Aircraft, MXS

Scale: 37" Wingspan

Design: Birger de la Peña

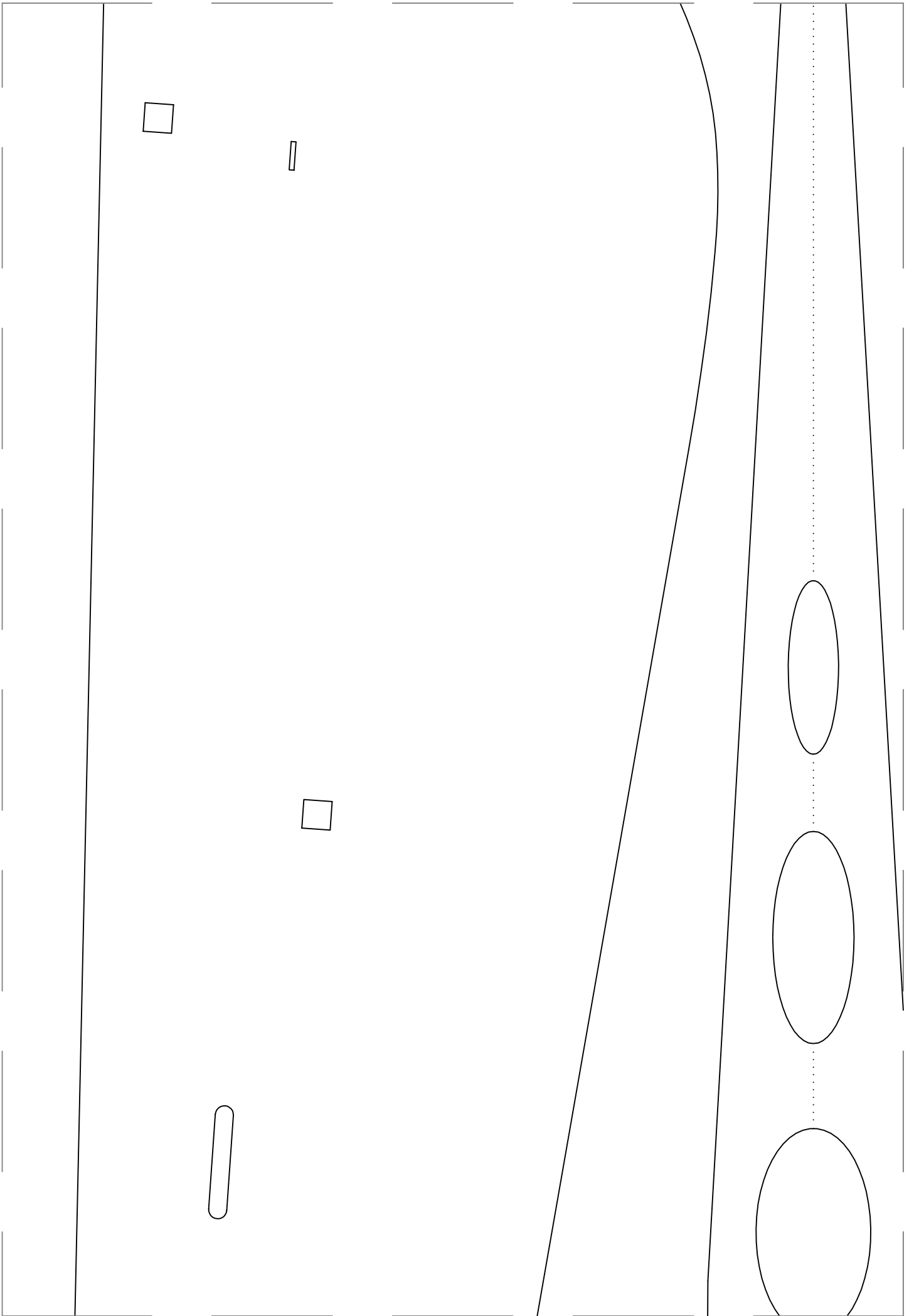

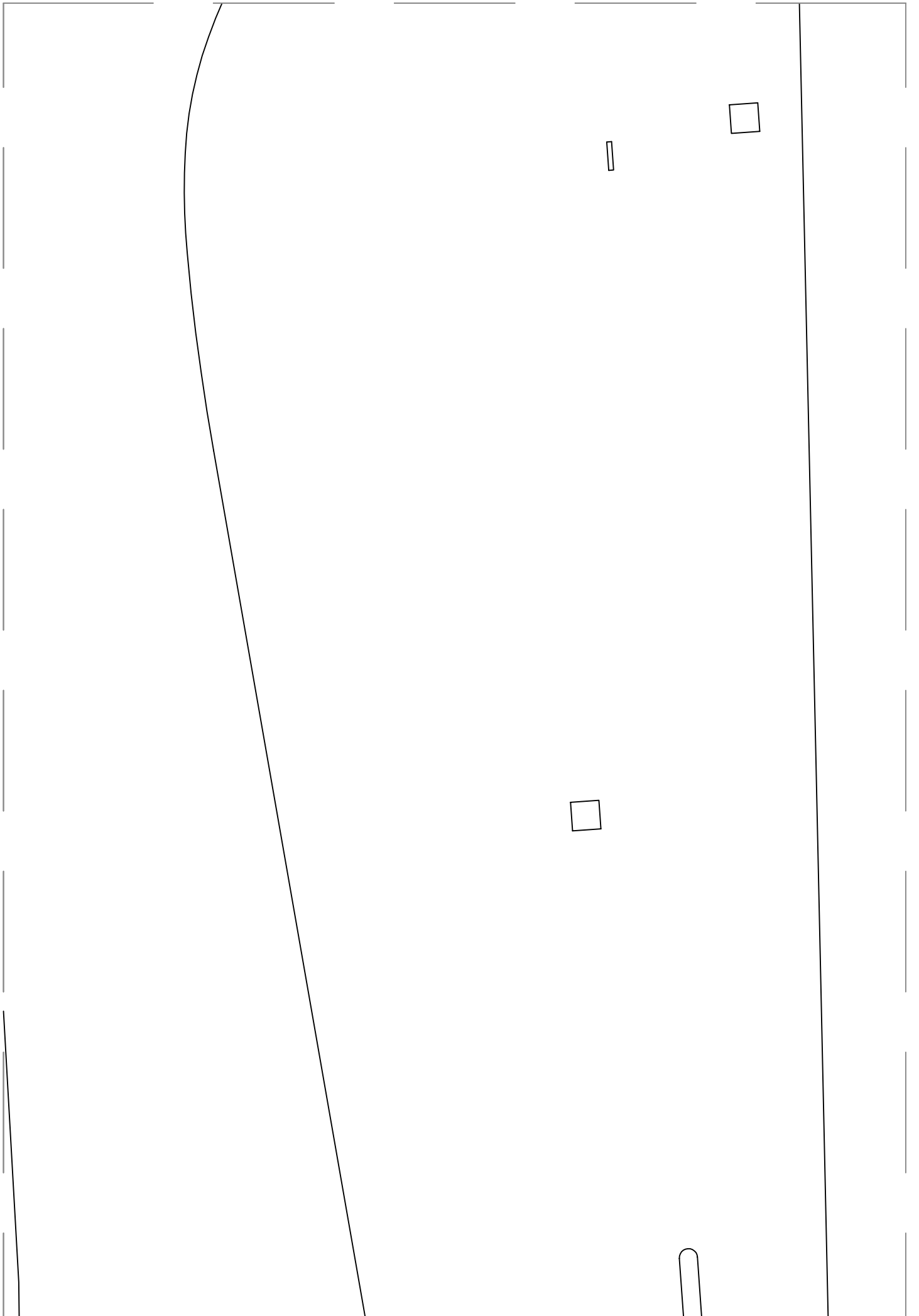

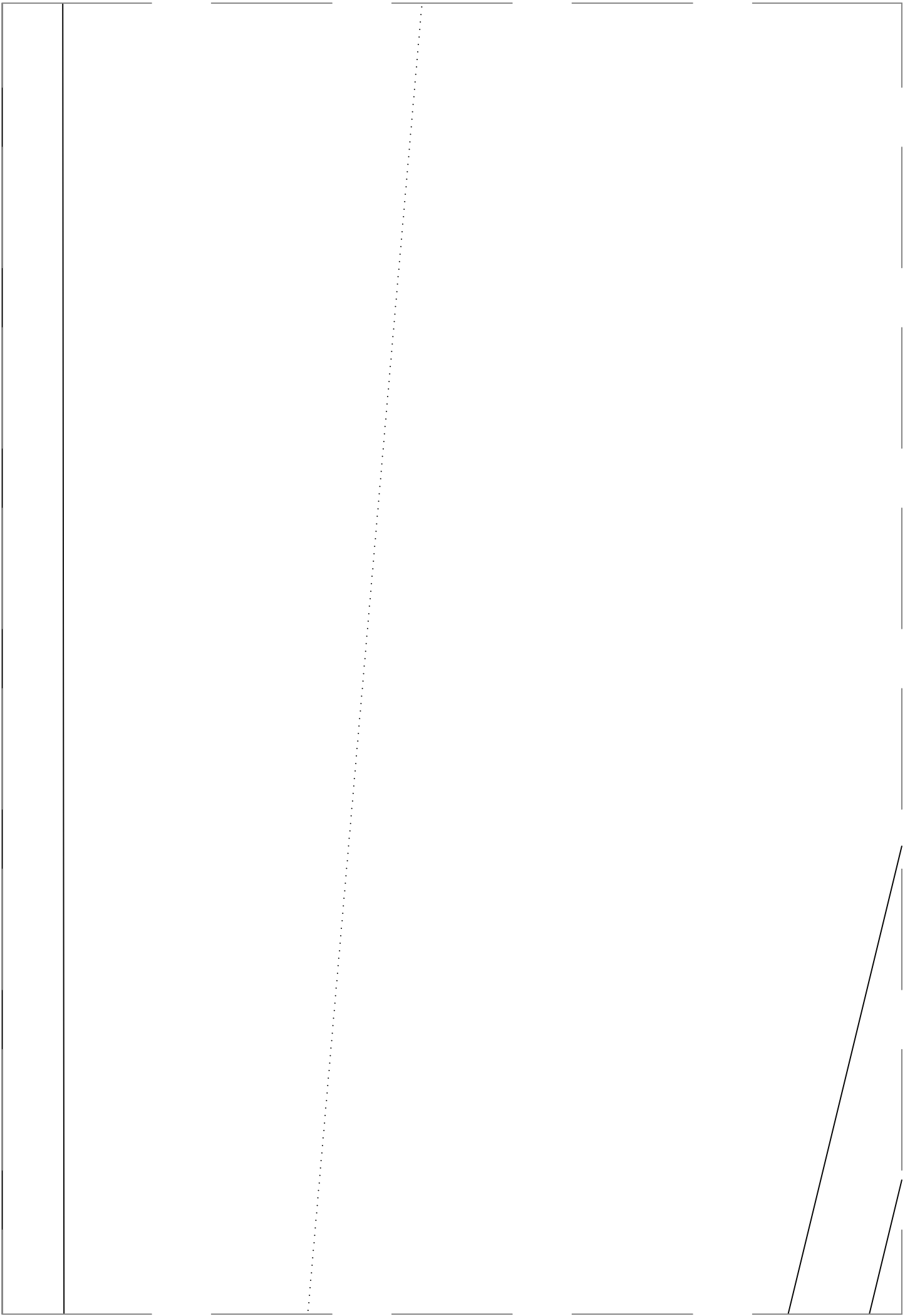

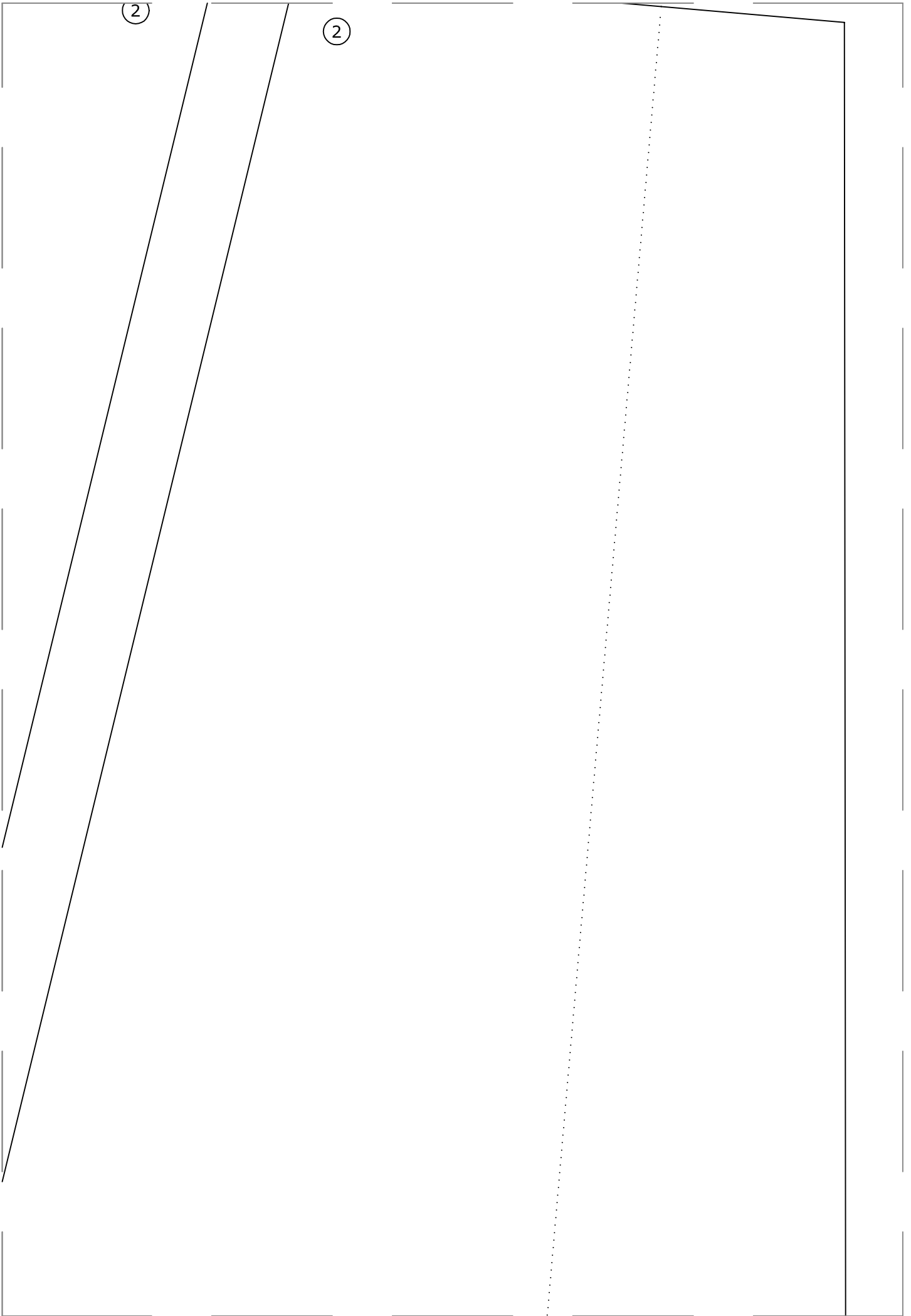

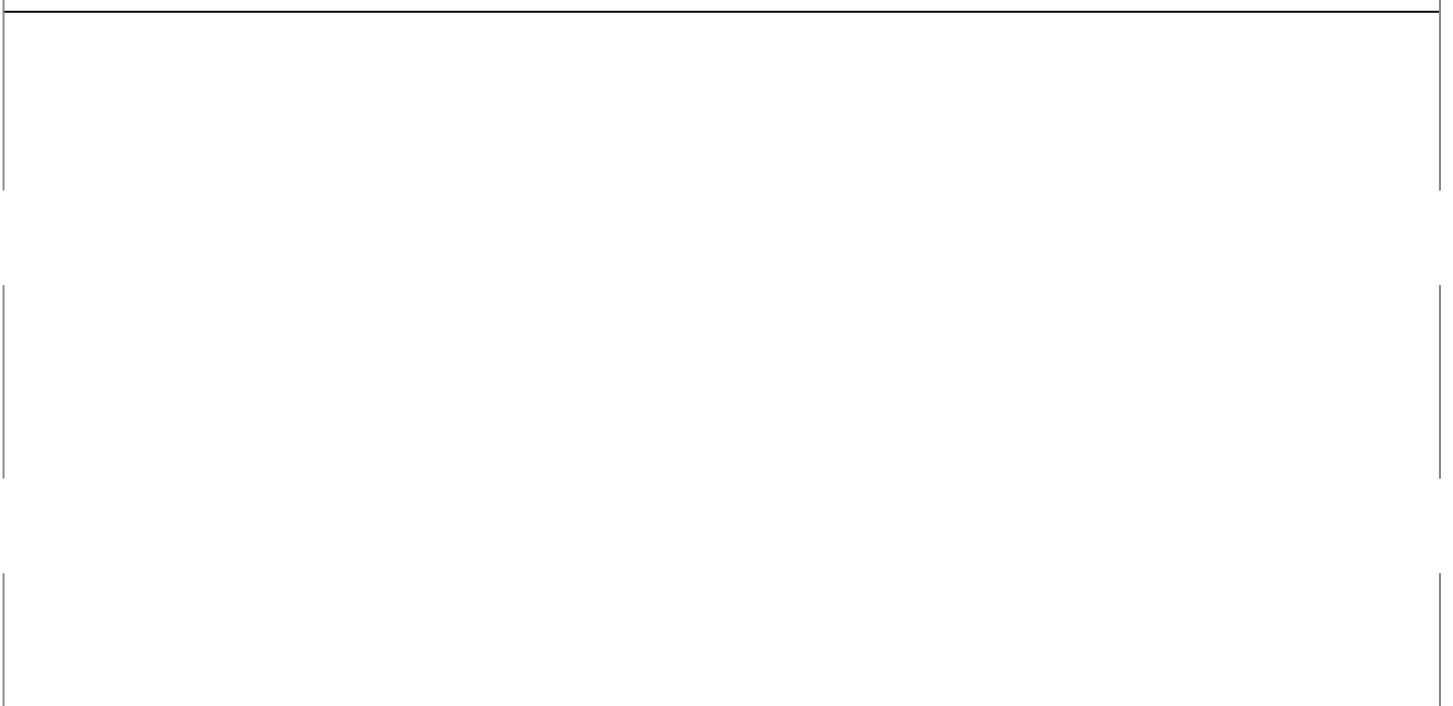
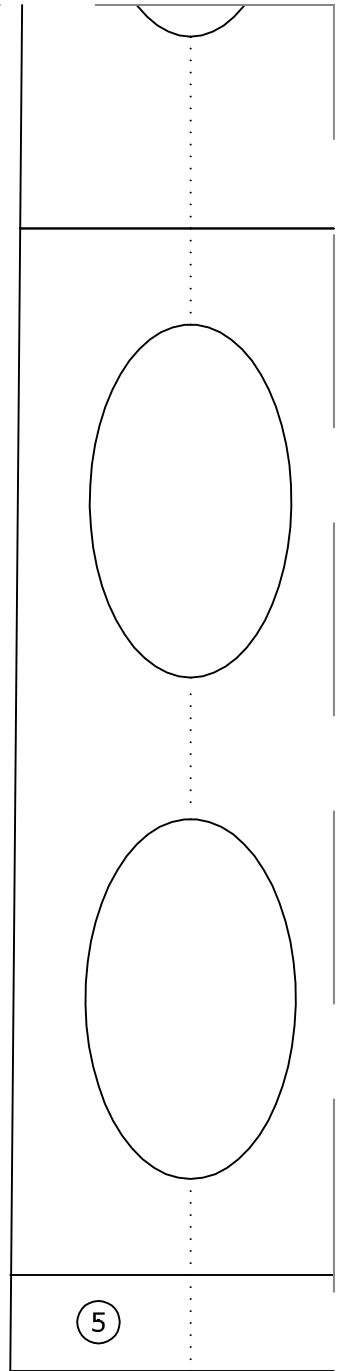
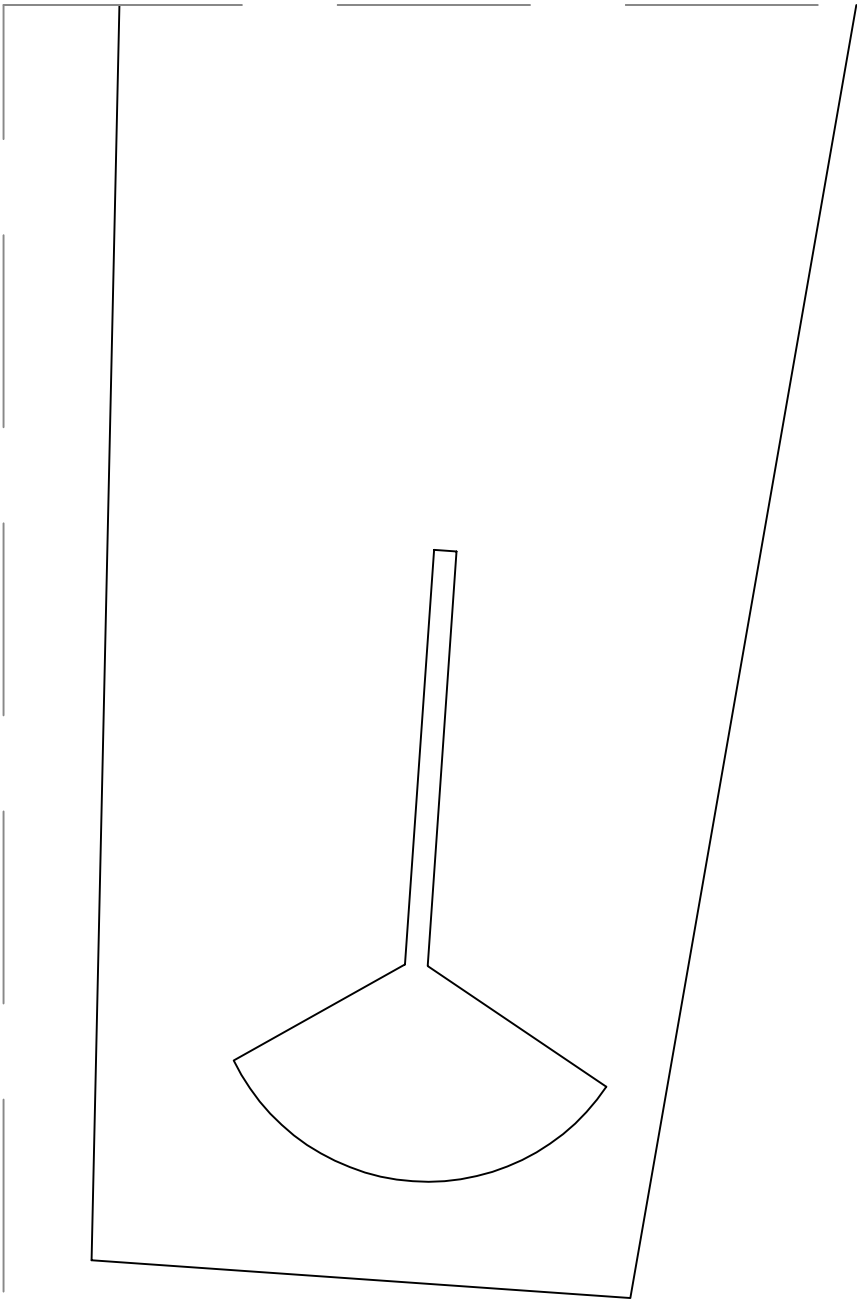

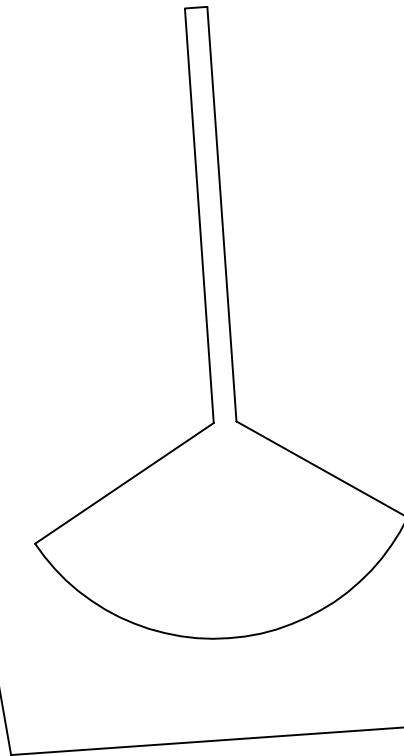
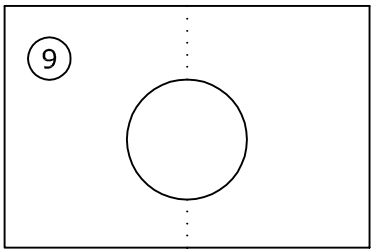
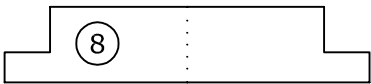
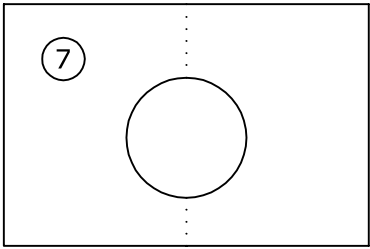
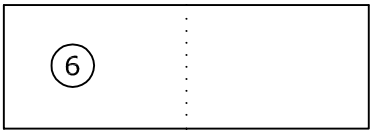

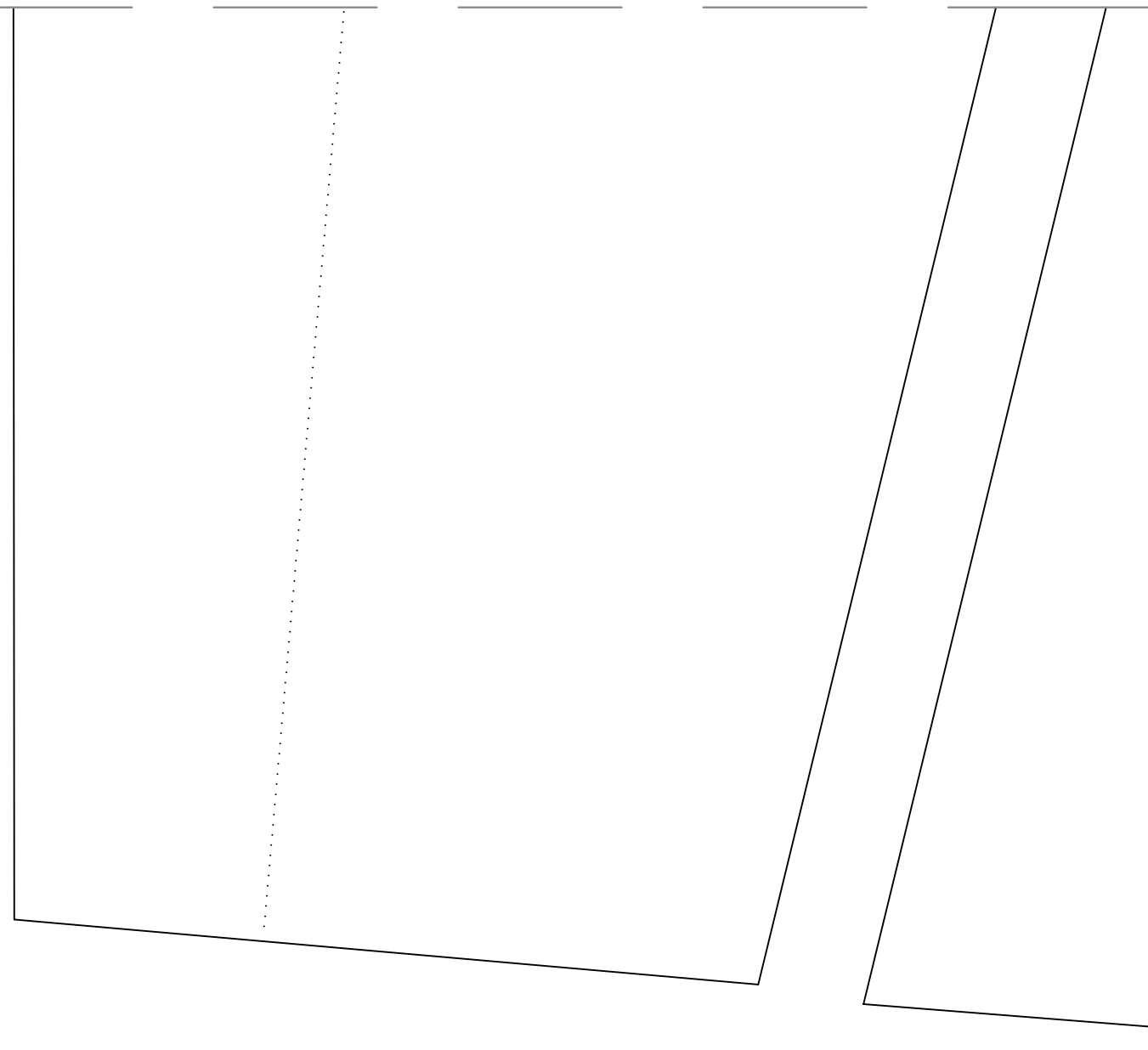

© 2008 - 2009, Birger de la Peña. All rights reserved.

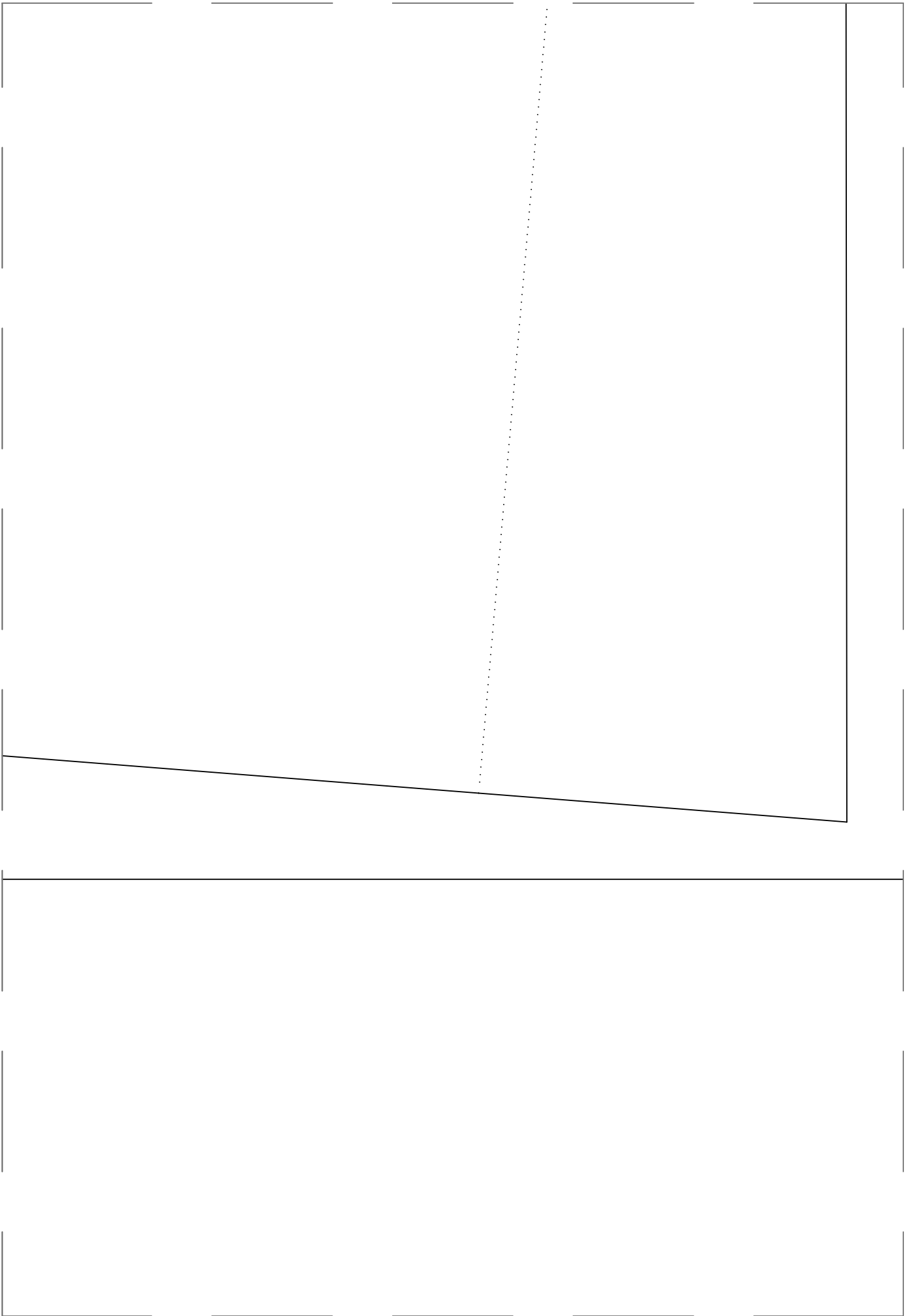

**Foam Sheet A**  
3mm Depron Foam

Model: MX Aircraft, MXS  
Scale: 37" Wingspan  
Designer: Birger de la Peña

Note: See assembly manual for double strengthening.

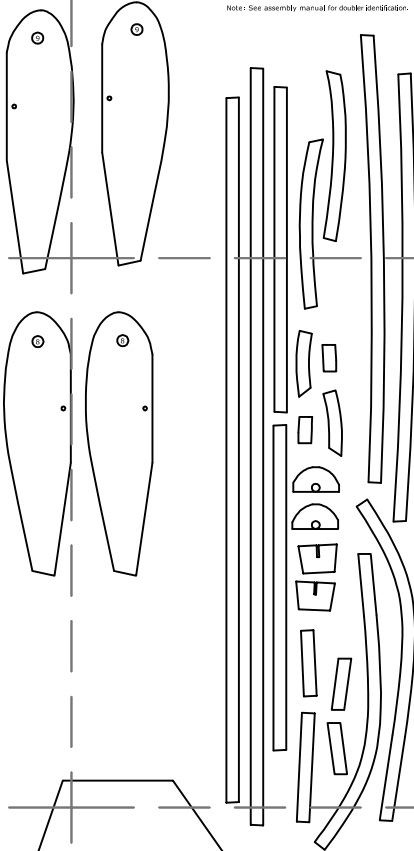

**Foam Sheet B**  
6mm Depron Foam

Model: MX Aircraft, MXS  
Scale: 37" Wingspan  
Designer: Birger de la Peña

**MXS**

37" Wingspan

Depron Construction

Birger de la Peña  
bdelapen@gmail.com

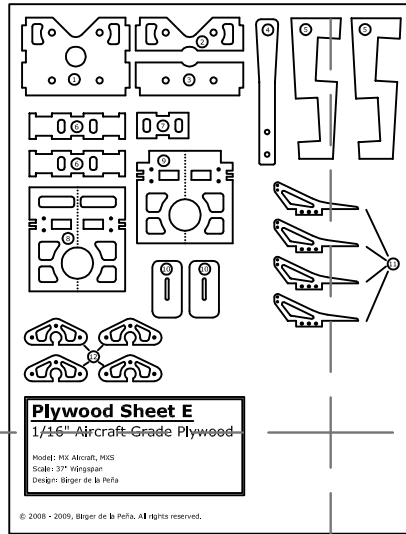

**Plywood Sheet E**  
1/4" Aircraft-Grade Plywood

Model: MX Aircraft, MXS  
Scale: 37" Wingspan  
Designer: Birger de la Peña

© 2008 - 2009, Birger de la Peña. All rights reserved.

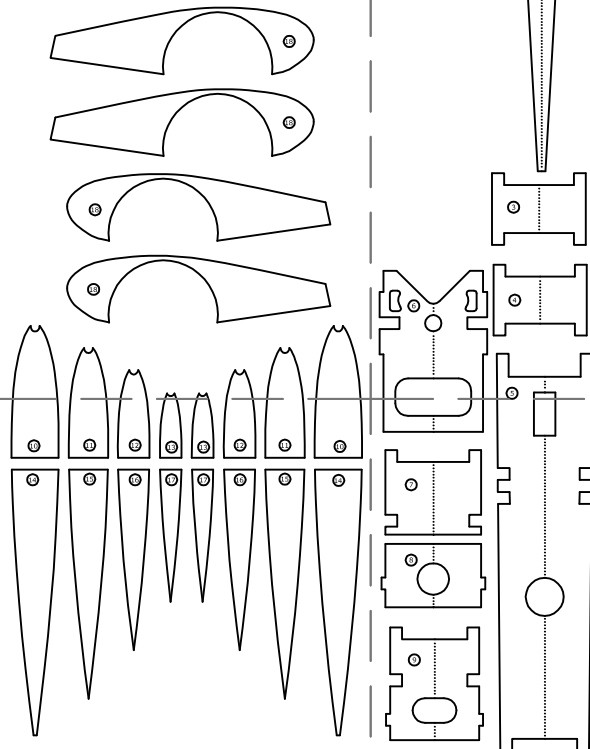

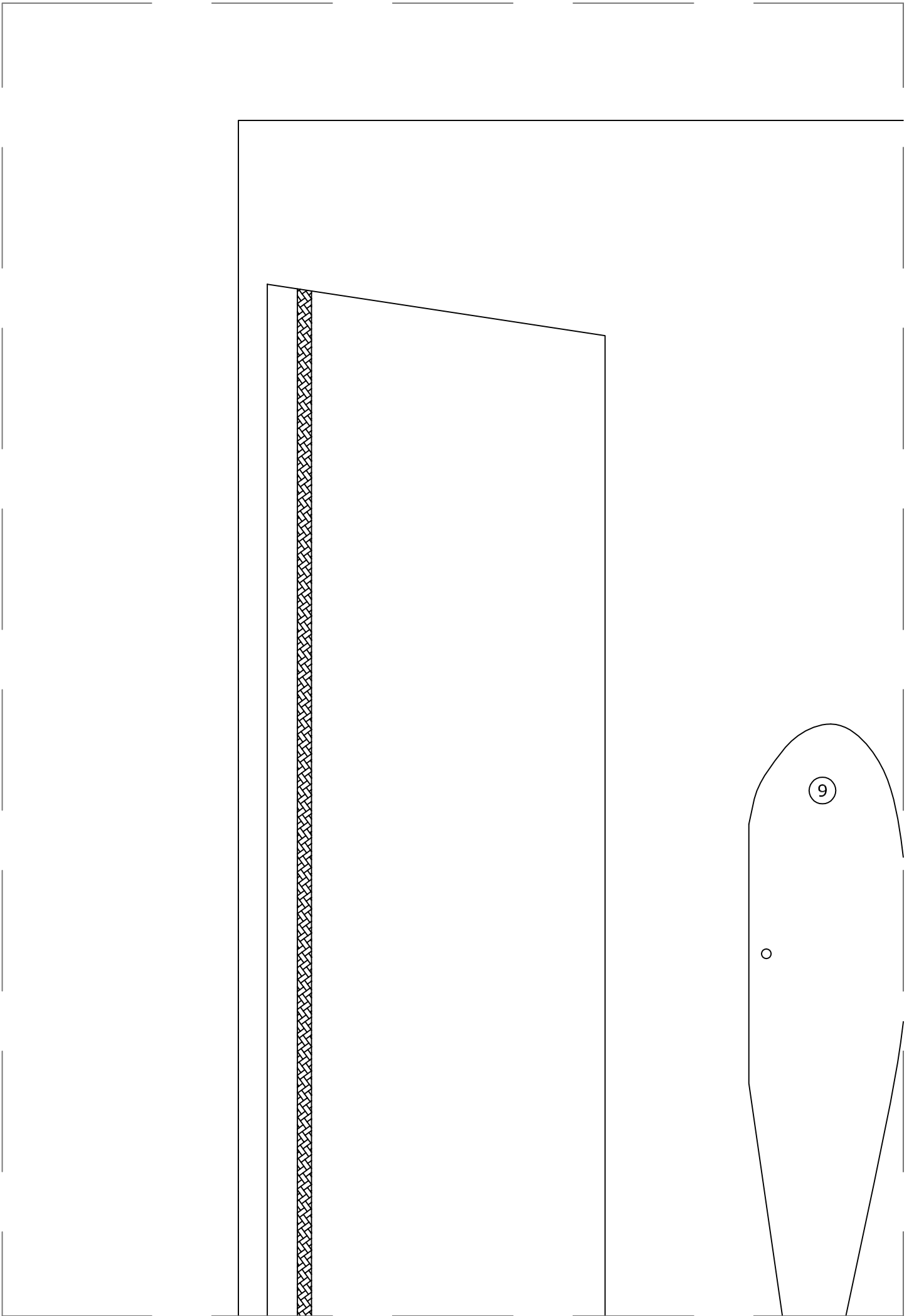

# Foam Sheet A

## 3mm Depron Foam

Model: MX Aircraft, MXS

Scale: 37" Wingspan

Design: Birger de la Peña

Note: See assembly manual for doubler identification.

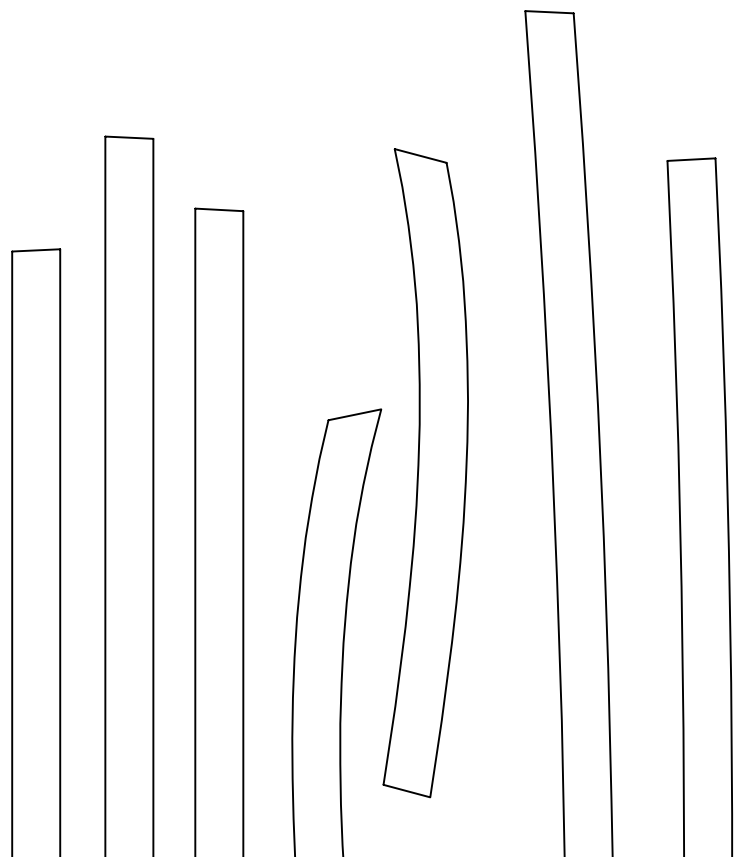
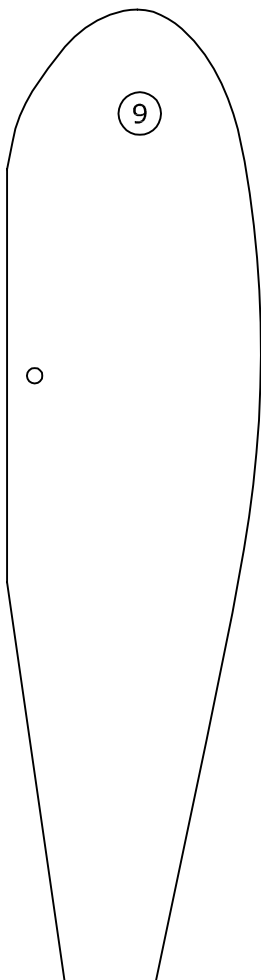

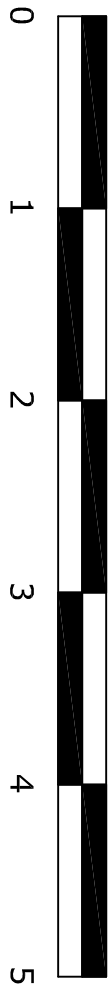

Scale: Inches



## **Foam Sheet B**

6mm Depron Foam

Model: MX Aircraft, MXS

Scale: 37" Wingspan

Design: Birger de la Peña

# **MXS**

37" Wingspan

Depron Construction

Birger de la Peña  
bdelapen@gmail.com

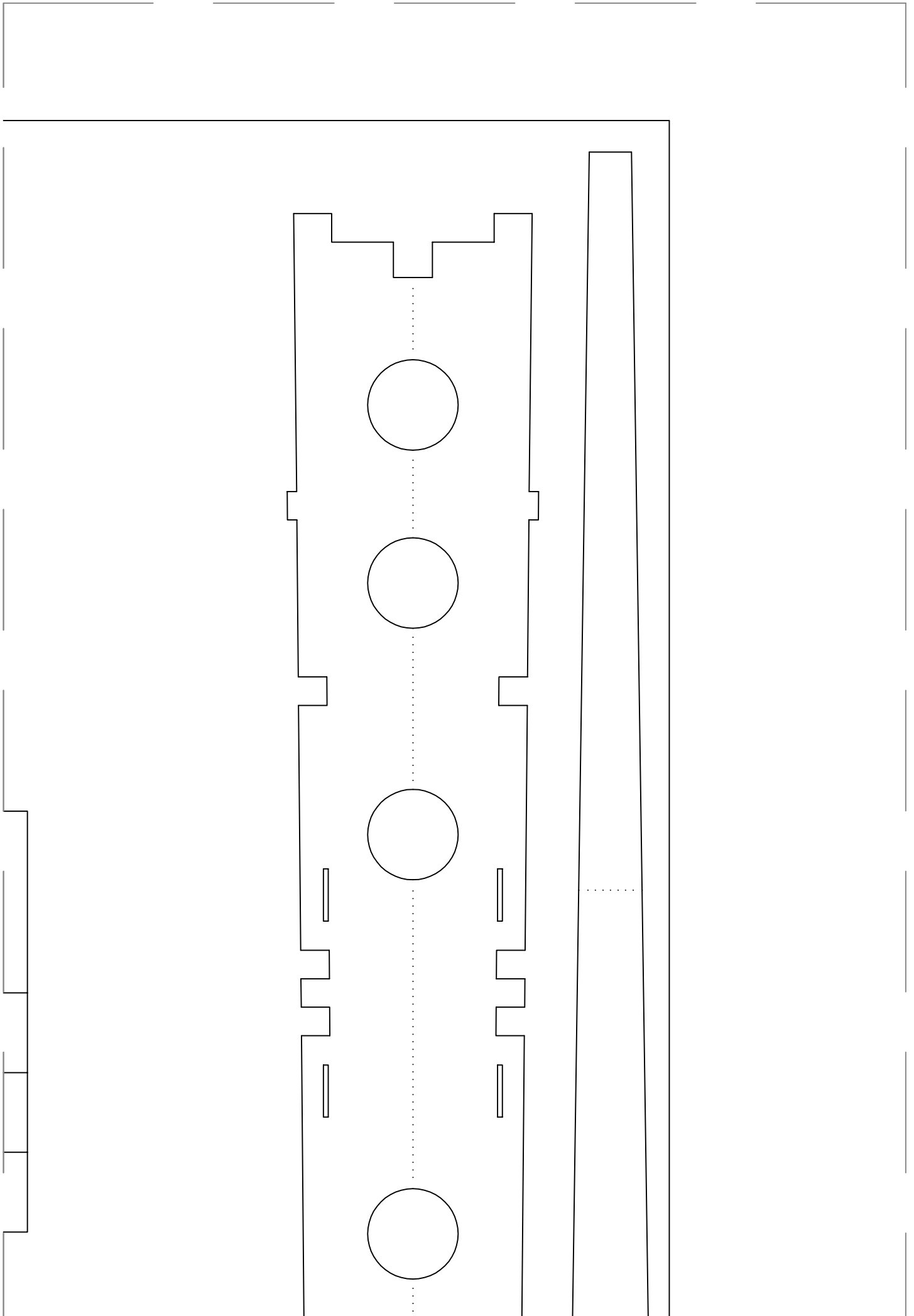

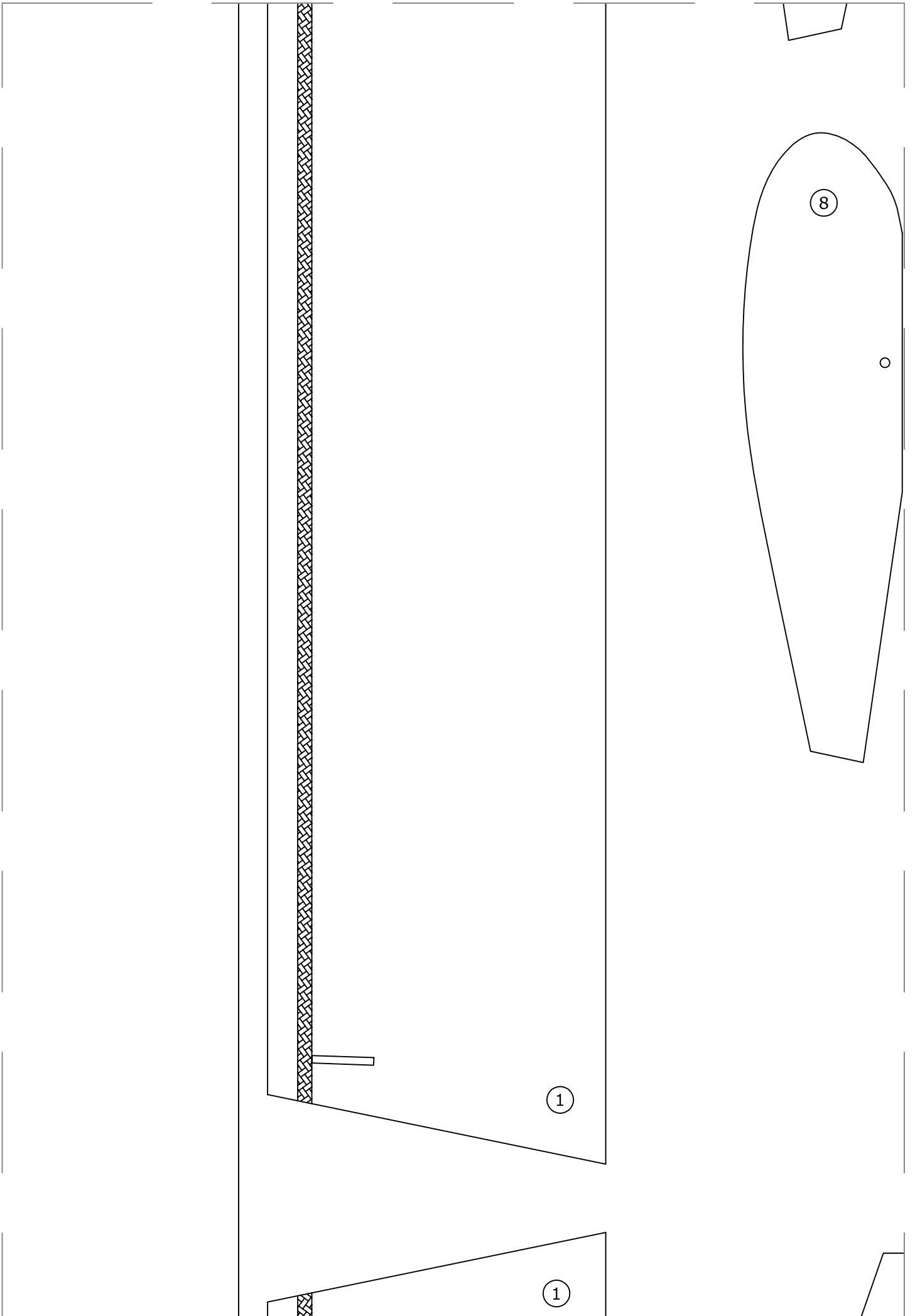

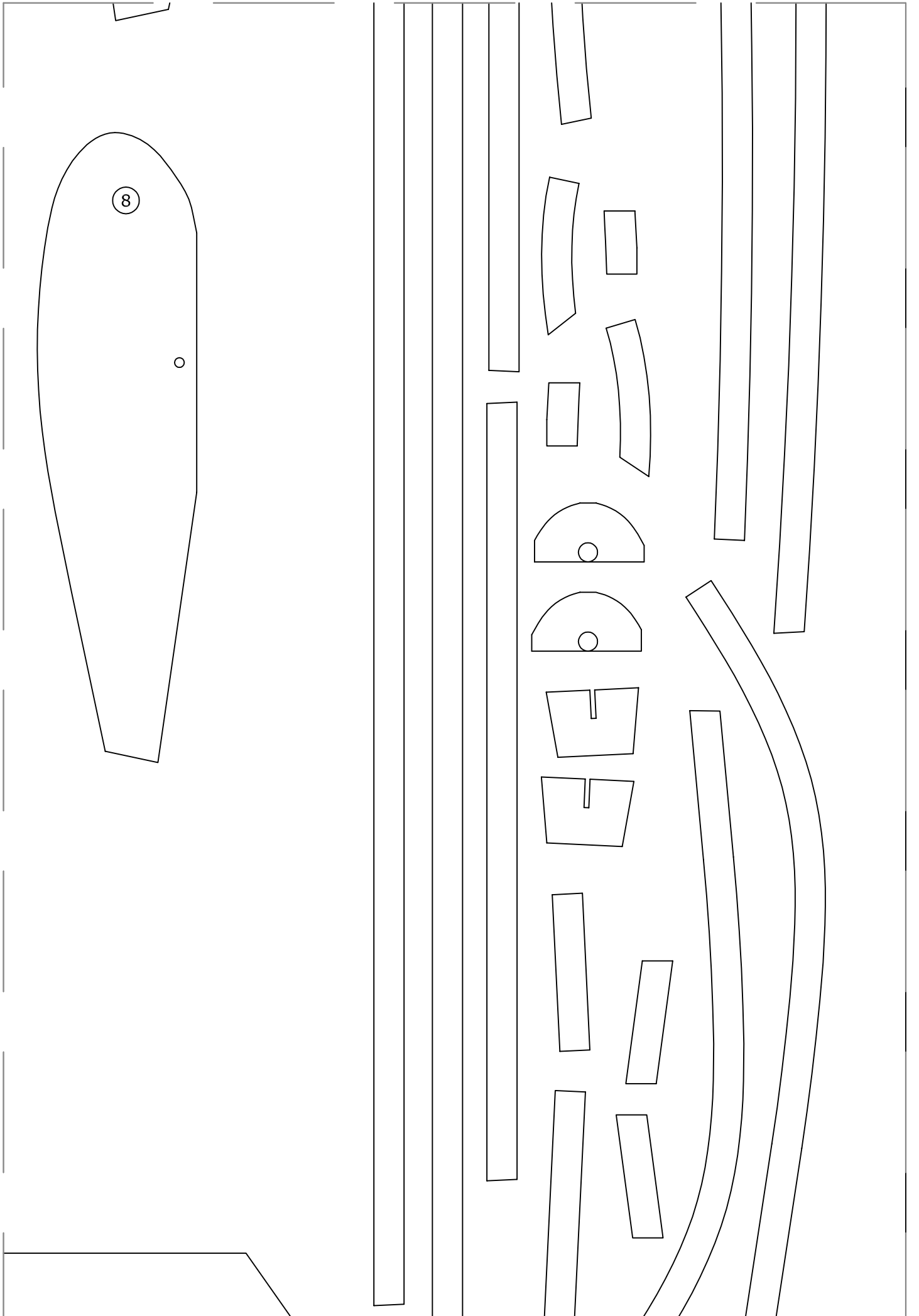

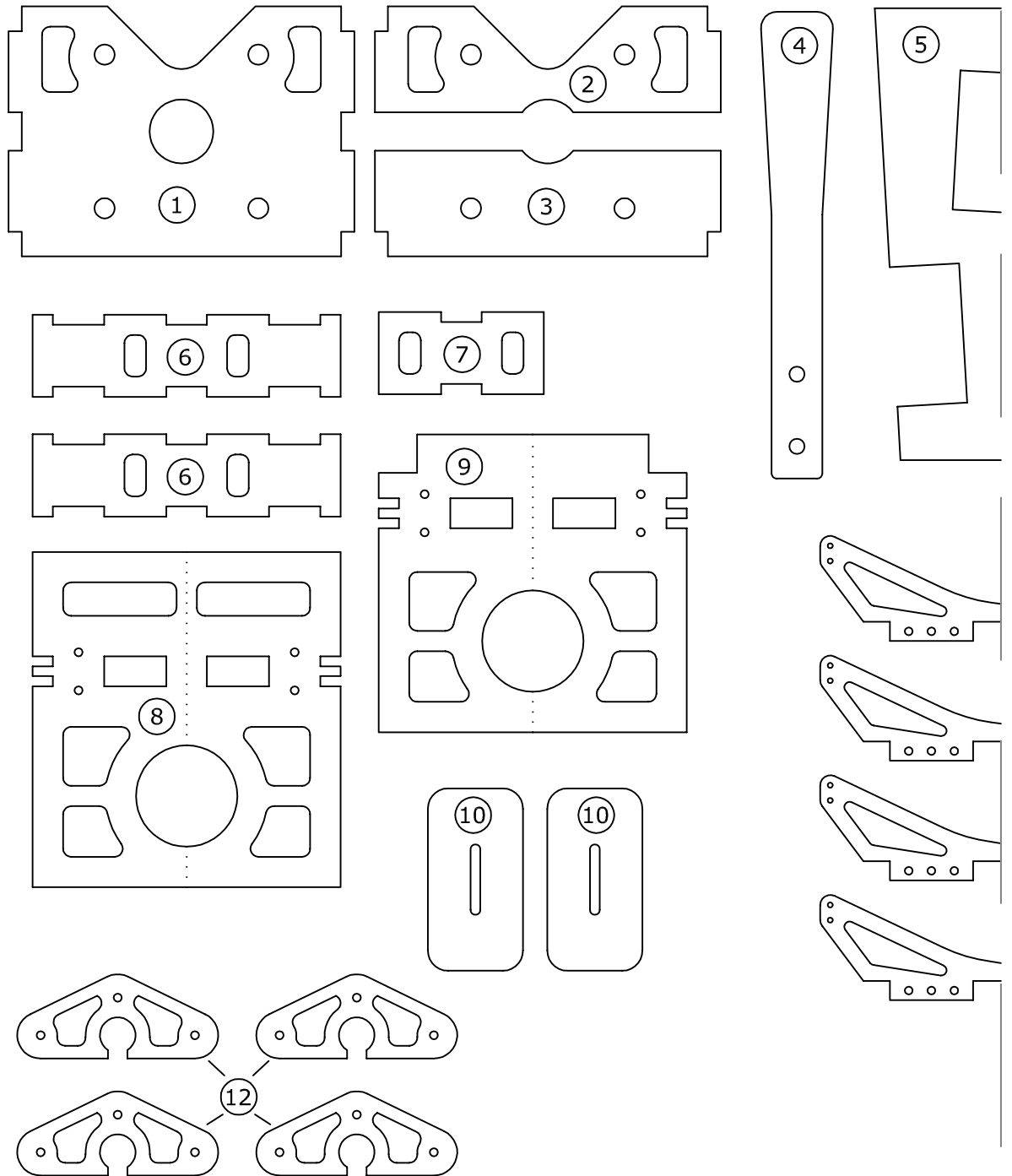

## **Plywood Sheet E**

1/16" Aircraft Grade Plywood

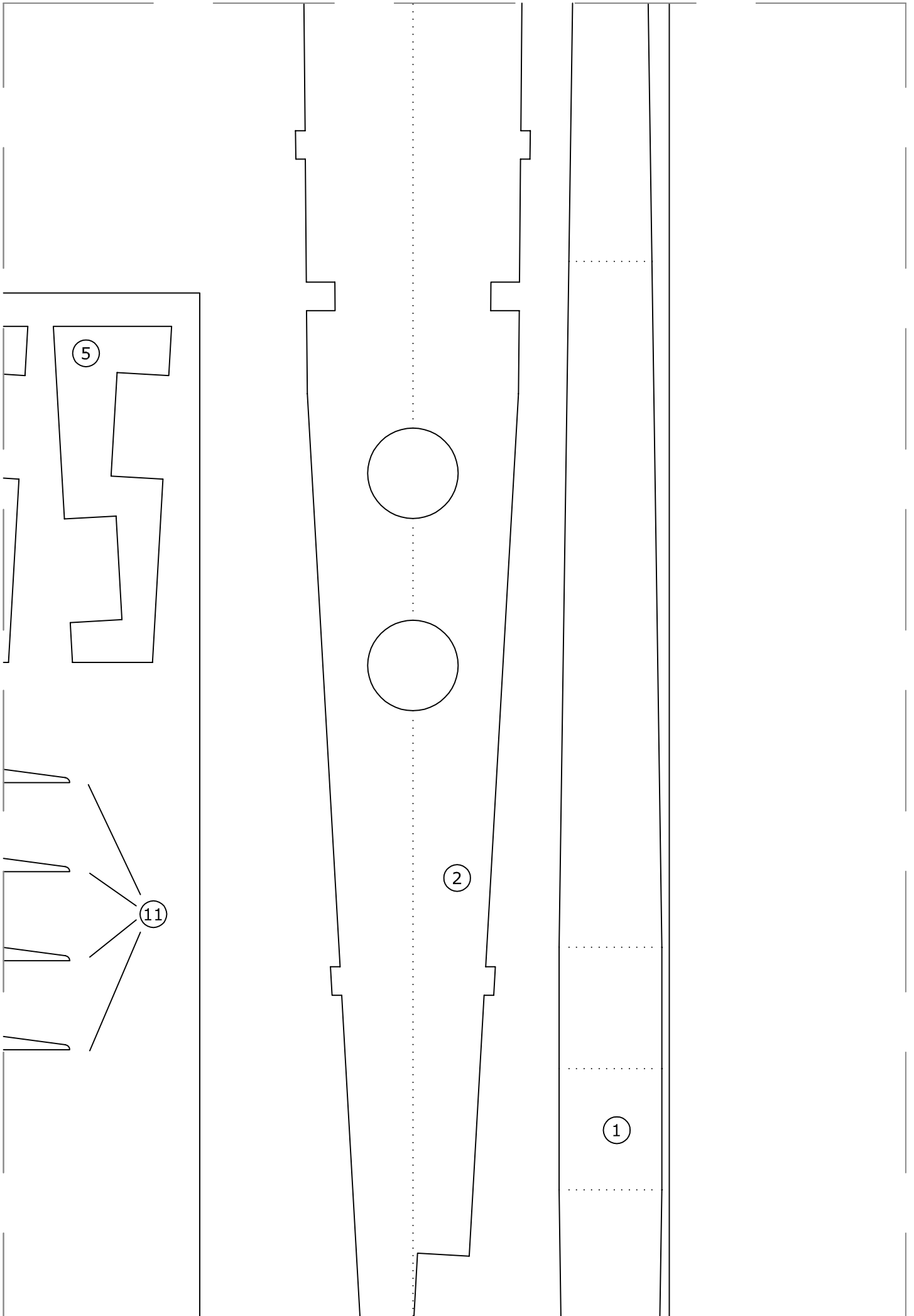

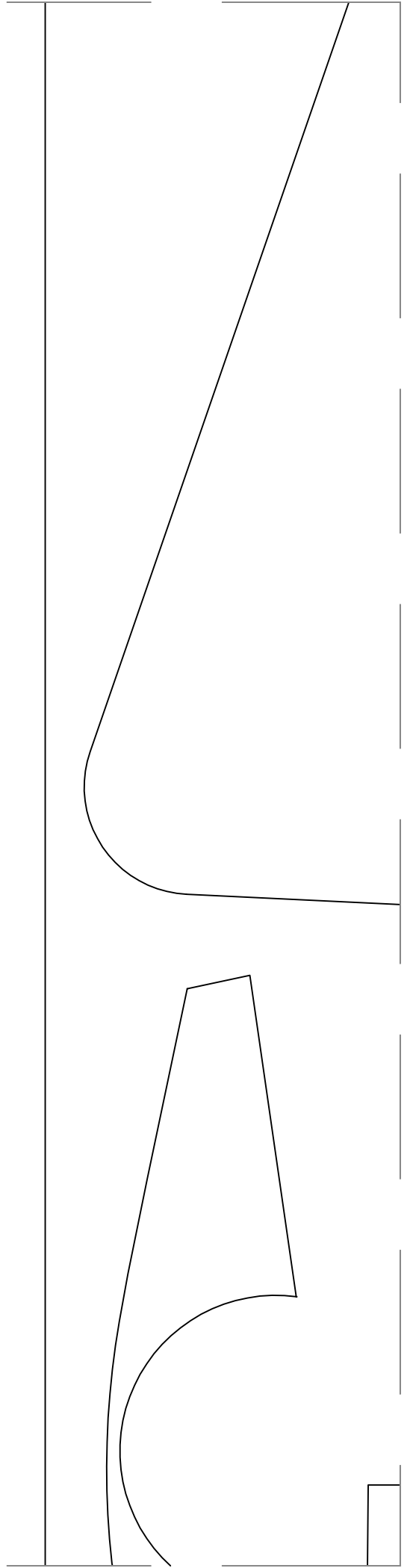
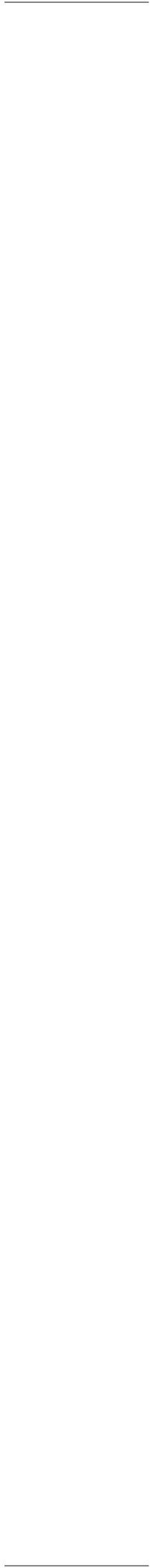
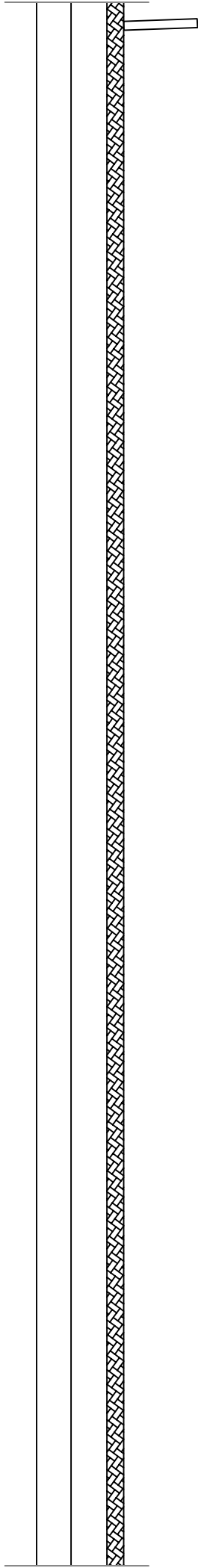

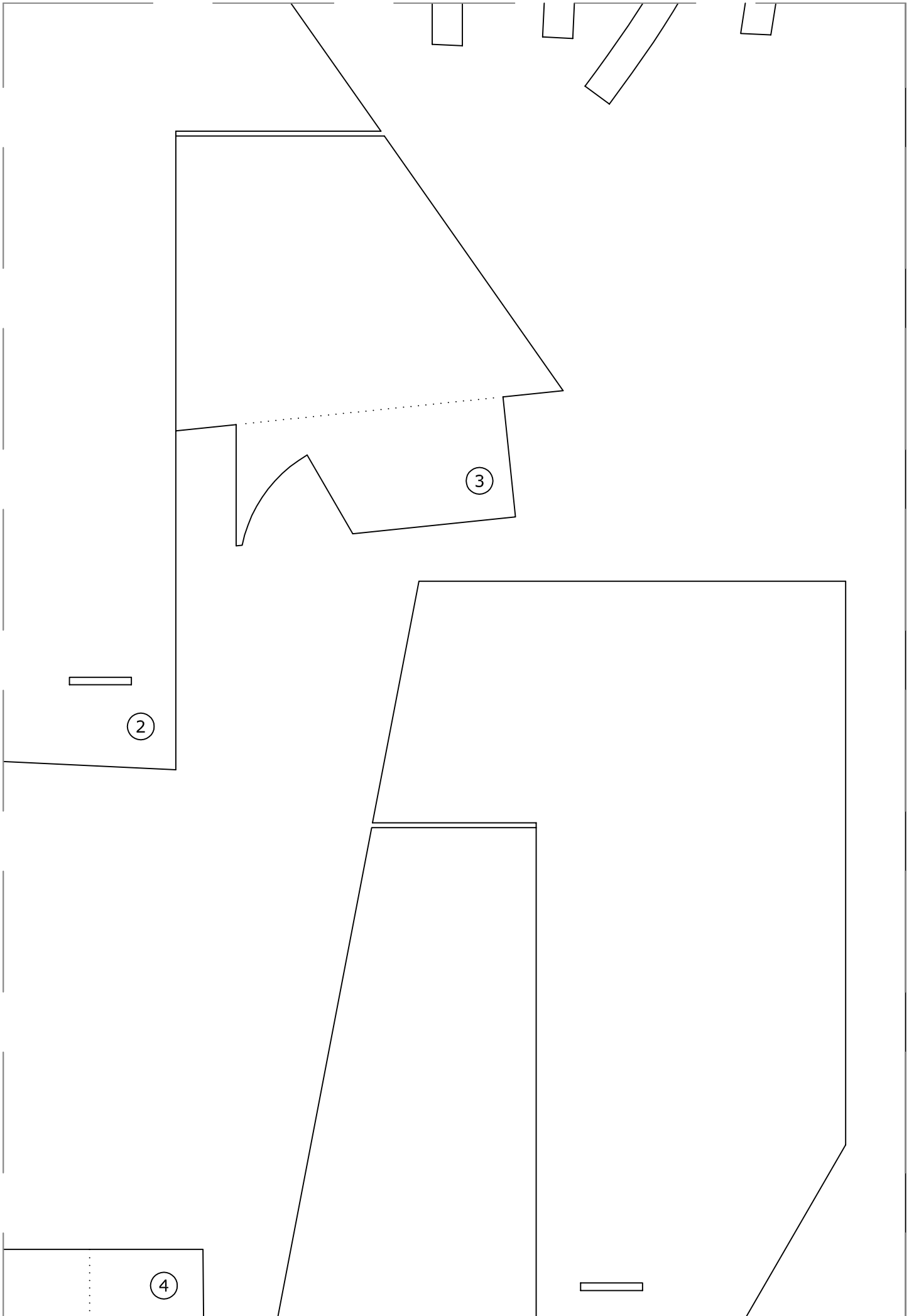

# 1/10 Aircraft Grade Plywood

Model: MX Aircraft, MXS

Scale: 37" Wingspan

Design: Birger de la Peña

© 2008 - 2009, Birger de la Peña. All rights reserved.

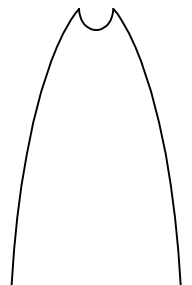
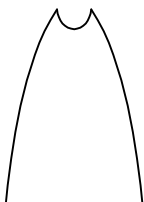
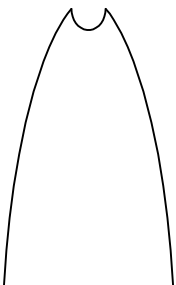
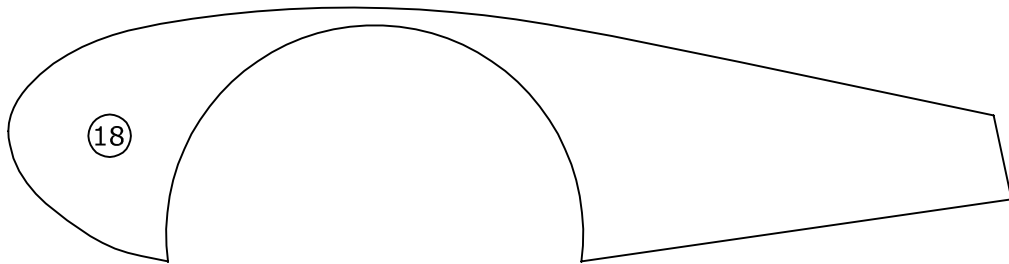
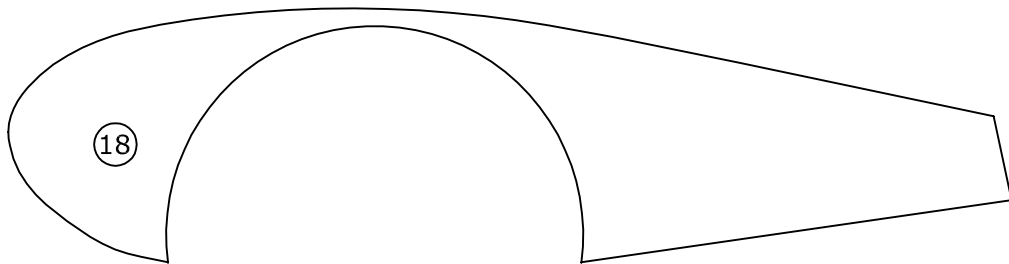
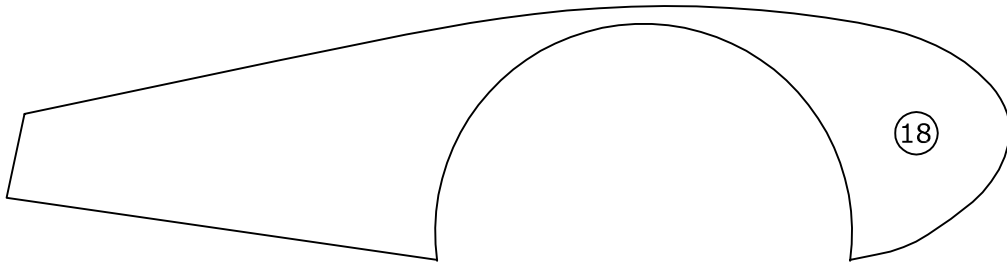
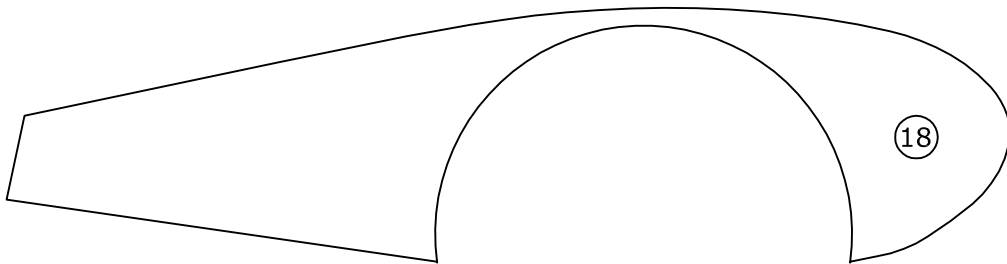

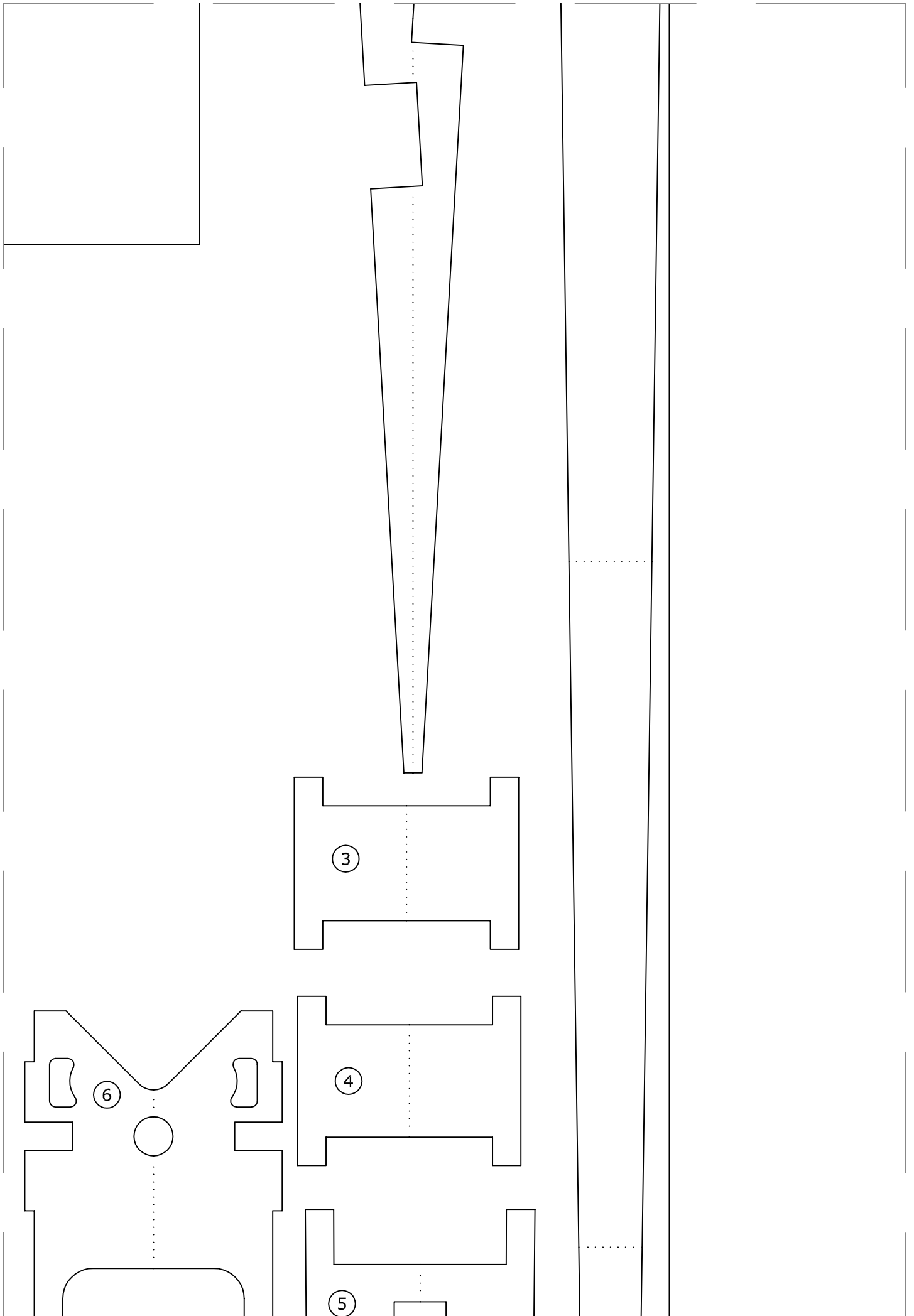

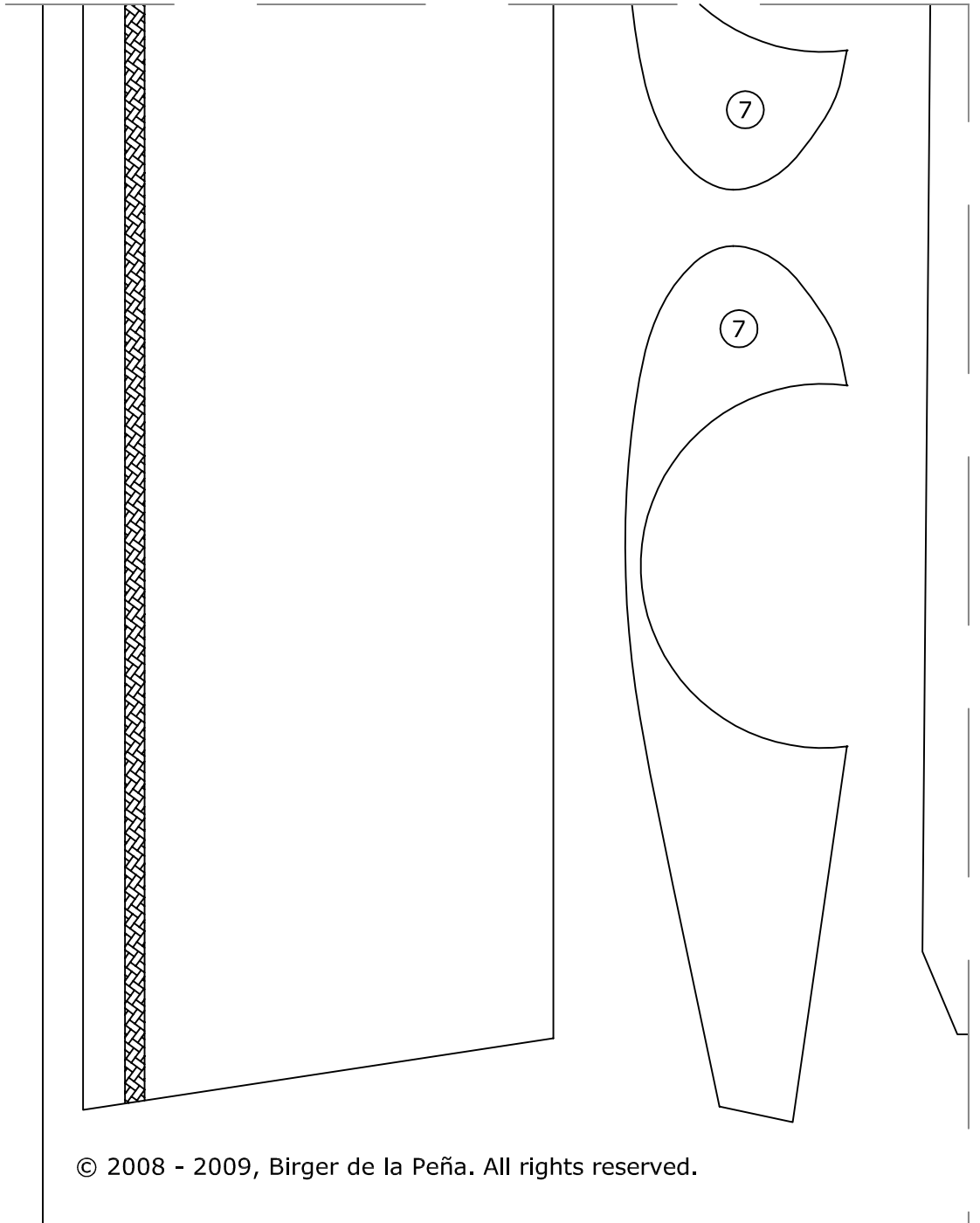

© 2008 - 2009, Birger de la Peña. All rights reserved.

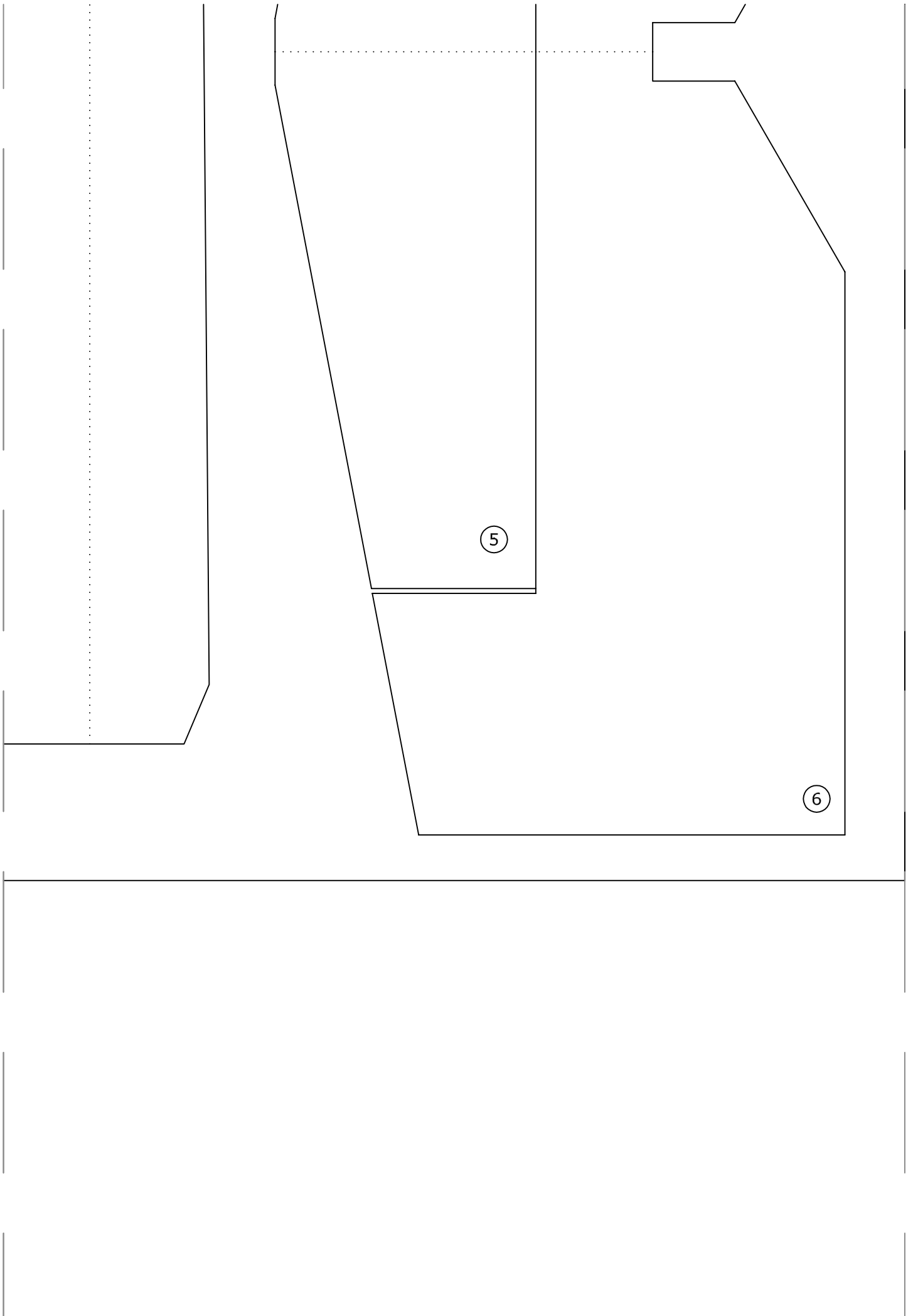

5

6

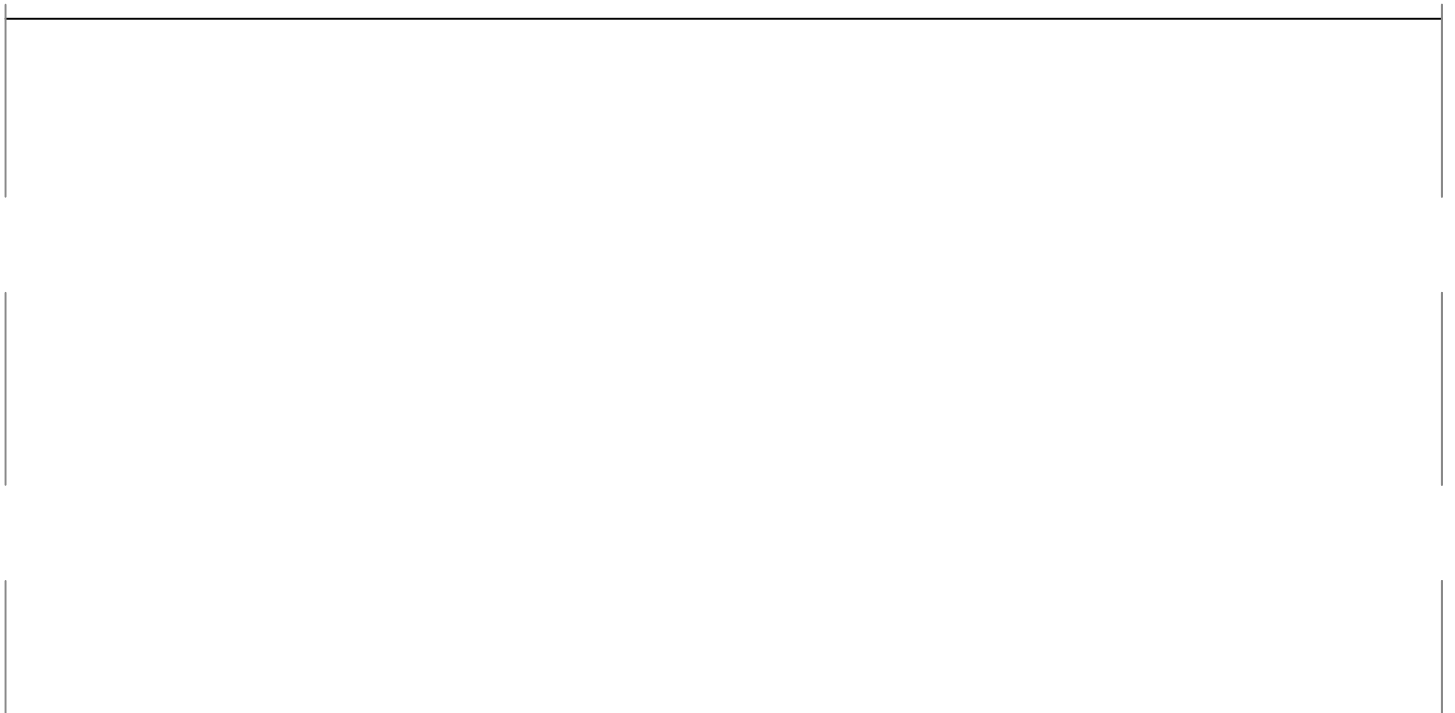
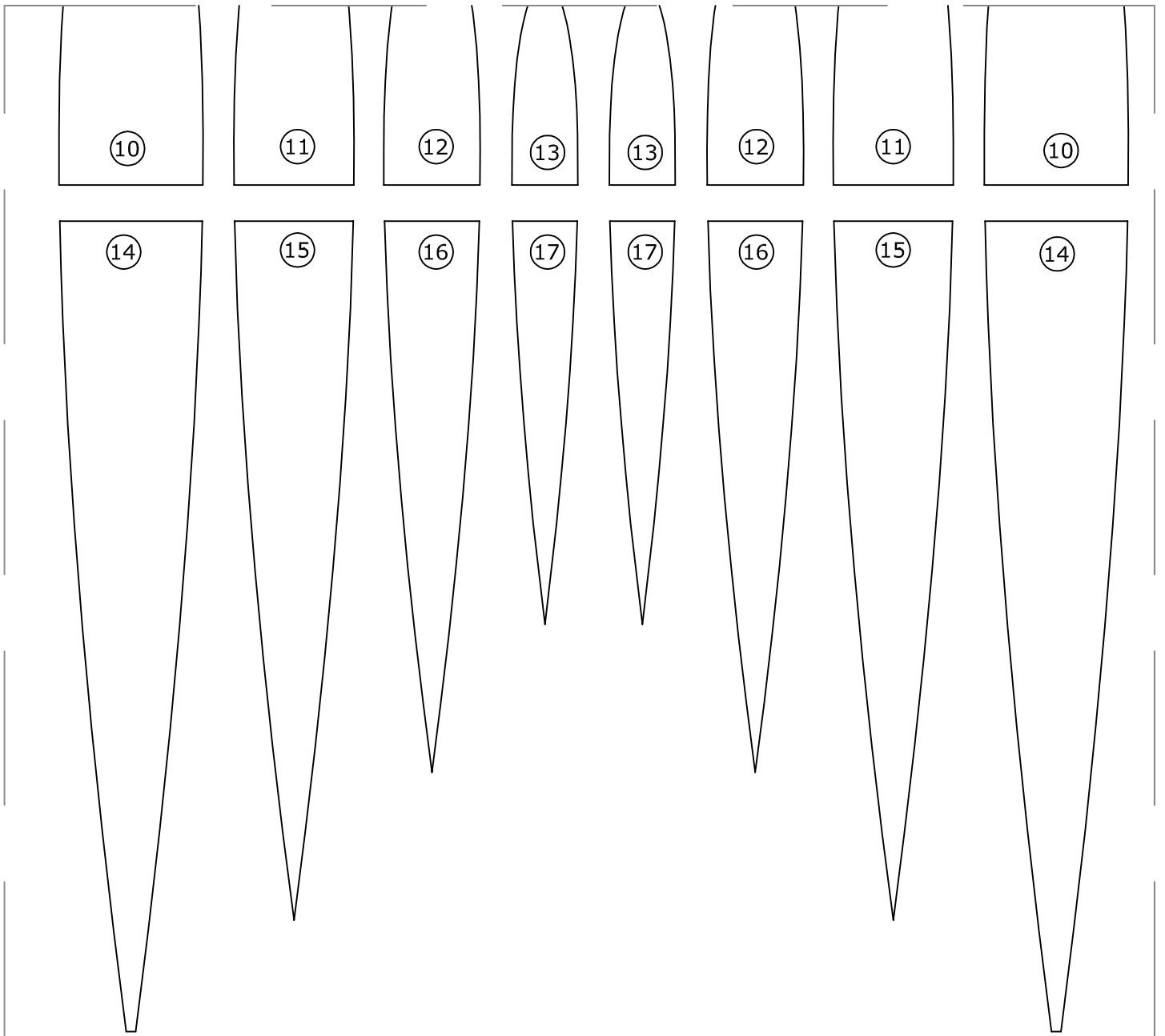

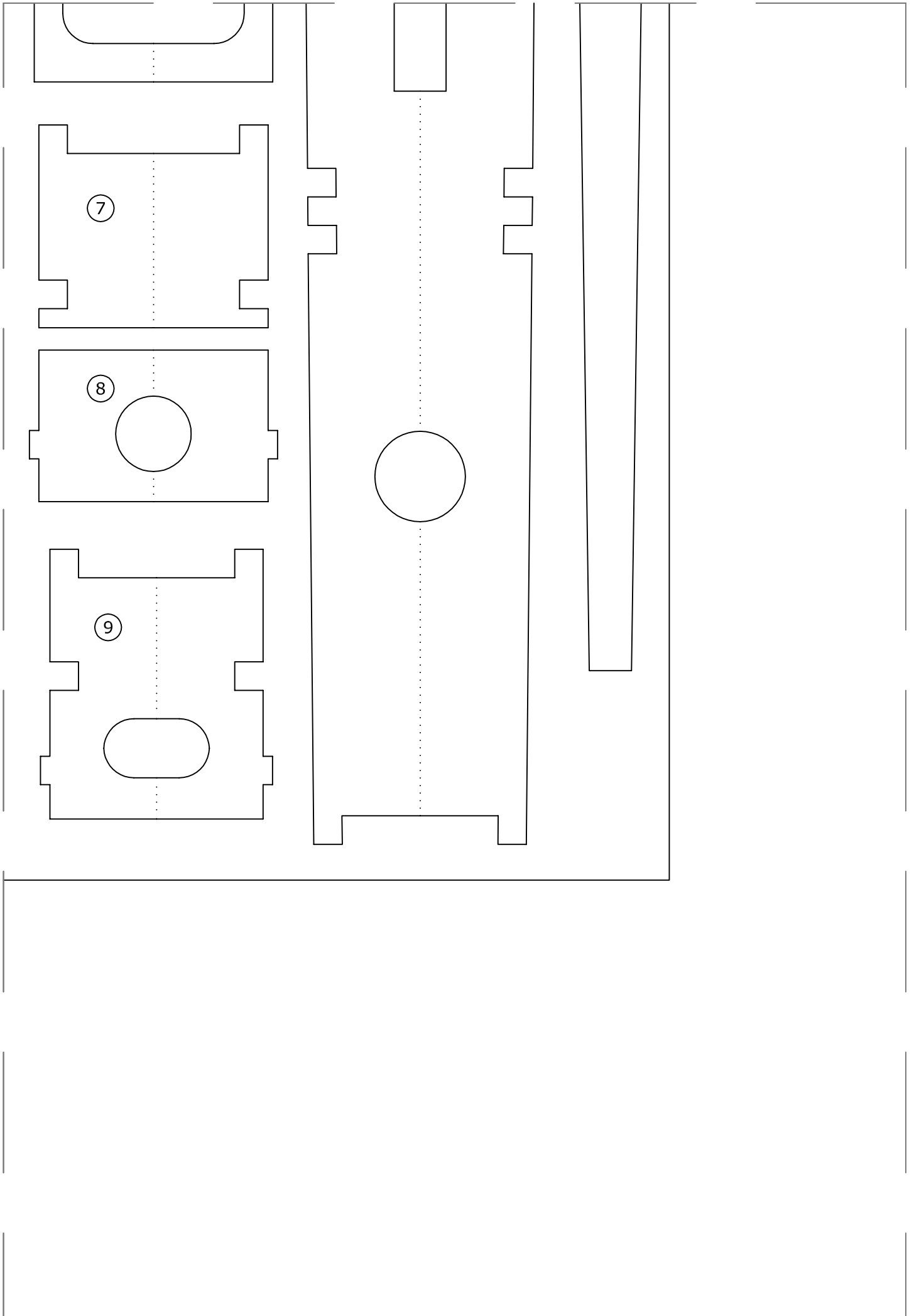

# MXS

DESIGNED BY BIRGER DE LA PEÑA



## Specifications:

Wingspan:	37"
Length:	33 3/4"
Wing Area:	332 in <sup>2</sup>
AUW:	15.6 oz
Wing Loading:	6.77 oz/ft <sup>2</sup>

# General information

Thank you for choosing the MXS designed by Birger de la Peña. A lot of time and effort have gone into the design and design of this plane and we strive to provide the best product possible.

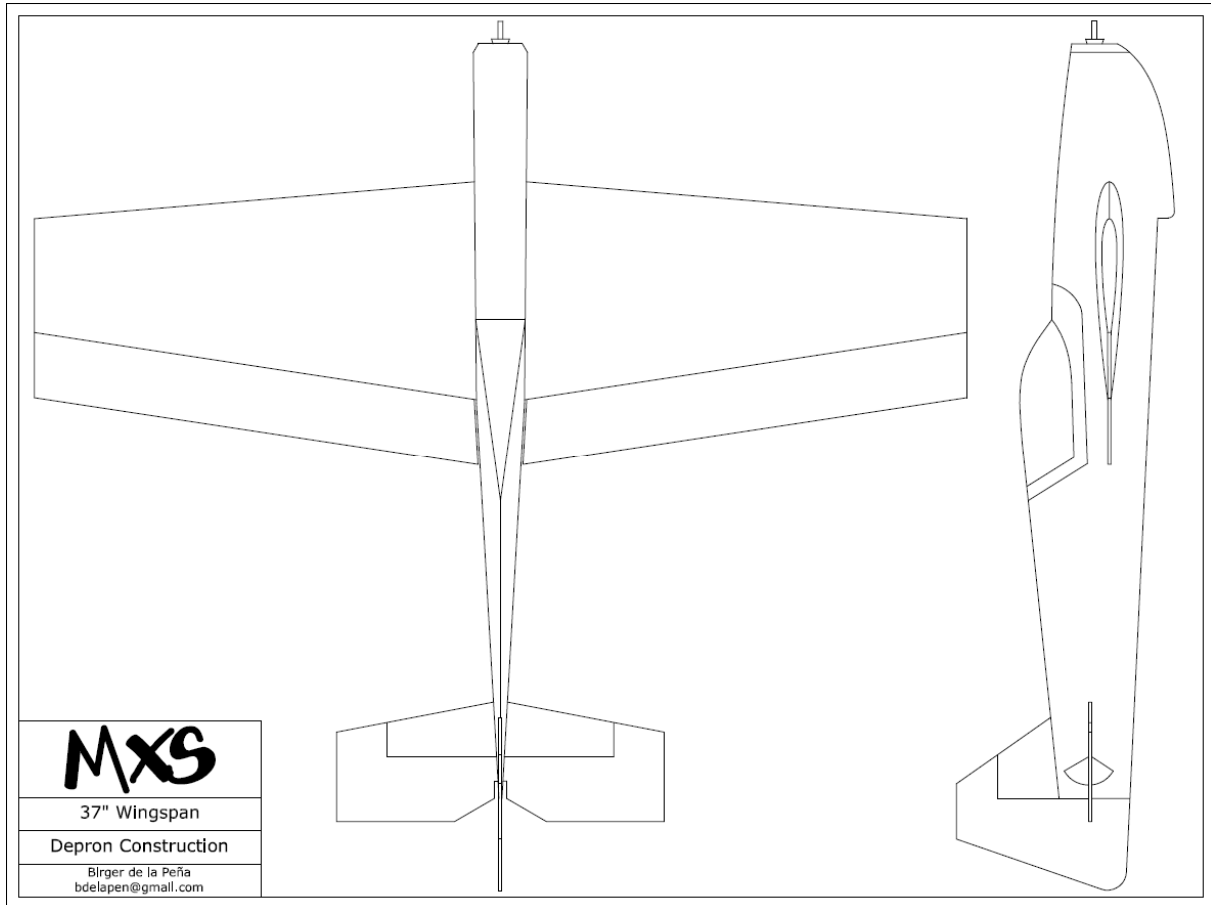

Figure 1 - MXS Plan View

## Important!

- **The MXS is an advanced aerobatic airplane that does not provide self recovering flight characteristics; it is intended for intermediate to advance pilots.**
- **In addition, the MXS utilizes advanced foam airplane construction techniques and is not intended for the novice builder.**
- **If you have built at least 2 scratch or kit built airplanes, at least one of them foam and if you have flown at least 2 aileron airplanes before then you will get hours of enjoyment out of the MXS.**
- **If this is your first scratch built airplane and/or if this is your first aileron airplane then we encourage you to build and fly an aileron trainer first.**

A remote control (RC) airplane is not a toy and can cause serious bodily harm and property damage. It is the builder's responsibility to put together an air worthy airplane and the pilot's responsibility to fly it safely. Please make sure that you conform to all local regulations and safety standards when flying this and any other RC airplane. Remember, Safety is not an accident!!!

## Before you begin

We recommend reading through the instructions completely before starting any work on the airplane (including cutting the foam). Familiarizing yourself with the entire construction process will help you avoid making any mistakes when cutting or preparing parts or when assembling pieces. Take care to assemble the components as shown and in proper alignment. Remember the more care you take in this process the better the end result and the better the completed airplane will perform.

## Cutting Depron Foam Tips

The following are some recommendations on successful creation of the Depron parts required to put together the MXS aircraft.

**Do not cut the foam at this time as there are special notes regarding cutting some of the parts in the build instructions; cut the parts out from the sheets when requested!!!**

One of the largest tasks in the construction of the MXS is cutting out the Depron Foam pieces, there are approximately 80 foam pieces used in the process. Although this is by no means a complete tutorial on cutting Depron foam here are a few pointers that will make your job easier

- The part outlines are laid out on sheets by foam thickness. There are four layouts (2 on each printed sheet) and the thickness of the foam they are intended for is printed directly on the sheet. Cut the sheets to the outline that represents the size of the foam sheet they are intended for.
- Tackle one complete foam sheet at a time (i.e. do not spray all four sheets of paper at one time). The goal is to leave the paper on the foam for as little time as possible so that the least amount of adhesive transfers to the foam and the cleaning and prepping of the cut parts is as easy as possible.
- Spray the back of the sheets with repositionable spray adhesive. Place the sheets upside-down on a table and then place the Depron foam shiny side down on the sheets. Do not try to place the paper on the foam, it will fold and will not line up correctly! Once the foam has been placed on the paper flip the whole stack over and starting from the center *lightly* press the paper down on the foam to eliminate any wrinkles; start from the center of the sheet and work towards the outside. The paper will only remain on the foam for a

little while and you don't want to create too much adhesive residue on the foam by pressing too hard.

- Before you start cutting make sure you have a hobby knife with a very sharp (preferably new) #11 blade in it. Depron dulls blades very quickly and will tear easily if you use a dull blade. We recommend using a new blade at least every two sheets. If you are going to be building many Depron airplanes you should consider buying your blades in packs of 100!
- Start cutting out the foam pieces. We usually cut out one piece at a time. Use a straight edge wherever possible and try to cut to the middle of the line in the paper. Be extra careful that you don't tilt your hobby knife to either side, it should be perfectly perpendicular. The more care you take cutting out the pieces the better the airplane will fit together. Although this is by no means a "self aligning and locking design" there are enough alignment tabs available to make assembly and alignment fairly easy.
- Transfer any alignment marks from the paper templates to the foam pieces. No need to draw complete lines as long as you mark both ends of the line you can always review the position with a straight edge. Do not skip this step alignment will be much easier later if the marks are present.
- Remove the paper templates from the foam pieces and clean them thoroughly on all sides with rubbing alcohol. This will ensure that the parts are free from the spray adhesive, dust and foreign particles as well as any residue left over from the foam production process.
- Your parts are now ready for assembly.

# Table of Contents

1	Materials, Tools and Adhesives _____	6
2	Parts List _____	9
3	General Assembly Reference _____	12
4	Wing Skins and Wing Spar _____	13
5	Crutch Assembly _____	16
6	Fuselage Sides _____	21
7	Ailerons, Elevator and Rudder _____	24
8	Fuselage Assembly (Stage 1) _____	30
9	Power and Radio Gear installation _____	36
10	Fuselage Assembly (Stage 2) _____	39
11	Wing Assembly _____	44
12	Landing Gear and Wheel Pants _____	48
13	Final Assembly _____	54
14	Flight Setup _____	56

# 1 Materials, Tools and Adhesives

## 1.1 Materials

The following list shows the materials you will require to build the MXS. We have made every effort possible to include everything you will need but you may find that certain choices you make during the assembly may require some additional components.

### 1.1.1 Foam

- 2 x Sheets 2mm Depron Foam, 15" x 39".
- 1 x Sheet 3mm Depron Foam 13" x 39".
- 1 x Sheet 6mm Depron Foam 13" x 39".

### 1.1.2 Carbon Fiber

- 2 x Carbon Strip 6.0mm x 1.0mm x 1000mm.
- 3 x Carbon Strip 3.0mm x 0.5mm x 1000mm.
- 1 x Carbon Square Tube 3.0mm x 2.0mm x 1000mm.
- 1 x Carbon Hollow Round Tube 4.0mm x 3.0mm x 1000mm.
- 1 x Carbon Solid Rod 2.1mm x 1000mm (this is personal preference; you can use larger diameter / smaller diameter / hollow for push rods).

### 1.1.3 Balsa Wood, Plywood and Carbon Fiber Sheet

- 1 X ¼" Light Weight Triangle stock (You will need about 12").
- 1 X 1/16" Light Aircraft Plywood.
- Optional: 0.5mm Carbon Fiber Sheet.

### 1.1.4 Hardware (made or purchased)

- Firewall components (3) (1/16" plywood or 0.5mm carbon fiber).
- Landing gear mount components (6) (1/16" plywood or plywood & 0.5mm carbon fiber combination).
- Wheel pant mounts (4) (1/16" plywood).
- Tail Wheel Reinforcement Bracket (1/16" plywood).
- Control horns (4) (1/16" plywood).
- Crutch assembly – servo mount reinforcement plates (2) (1/16" plywood or 0.5mm carbon fiber).
- Battery Hatch Latch (optionally magnets or Velcro can be used).

### 1.1.5 Hardware (purchased)

- 4 sets of bolts, washers and lock-nuts for mounting motor (4-40 or 3mm).
- 100mm CF landing gear for Mini Electric Plane.
- 2" Light Weight Foam Wheels (50mm X 9 mm).
- 1/16" diameter music wire (for wheel axle – to suit selected wheels).
- 1/16" wheel collets (to suit selected wheel axles).
- Small steel or nylon washers (to suit selected wheel axles).

- Micro Tail Wheel Bracket and Axle (preferably steerable).
- 3/4" Light Weight Foam Tail Wheel.
- 0.032" music wire for making pushrods (diameter is personal preference).
- 4 x Micro E/Z links (to suit selected music wire).
- 4 x Mini E/Z connectors (to suit selected music wire).
- Hinge Tape.
- Packing Tape.
- Wire Keepers (for a well organized plane).
- Double Stick or mounting Tape (for mounting receiver and ESC).
- Velcro.
- Velcro strap/loop (for retaining battery).
- Kevlar Thread.

### 1.1.6 Power System

- Motor 150W - 200W (Hacker A20-20L was used on prototype).
- ESC 20A - 25A (Atlas 20A was used on prototype).
- Battery 3S LiPo 1200 - 1500 mAh (Thunder Power 3S 1320mAh was used on prototype).
- Spinner (1-1/4" electric was used on prototype).
- Propeller (10 X 4.7 APC Slow Fly was used on prototype).
- Any additional necessary connectors / wire / heat-shrink.

### 1.1.7 Radio System

- Receiver (micro / park flyer recommended) (Futaba R616FFM was used on prototype).
- 3 Servos (micro recommended, 1 high torque for Aileron) (Futaba S3114M were used on prototype) – Optional: Second Aileron Servo can be used if flaperons are desired.
- 2 Servo extensions for elevator and rudder servo.
- Any additional extensions and radio accessories.

## 1.2 Tools

Putting together the MXS requires standard hobby construction tools. We provide a list of the basic tools you should expect to use during assembly but you may find that for certain tasks additional tools could be beneficial.

- Hobby knife with #11 blade.
- Extra #11 blades.
- 2 Straight Edges or Rulers, preferably metal, one preferably 36" long.
- Small Square.
- Hobby or Razor Saw.
- Scissors.
- Removable Tape (painters tape works well, do not use standard masking tape as it will tear the foam when removing).
- Screw drivers, wrenches, Allen wrenches and pliers to fit your selected hardware.
- Sanding block and sand paper.
- Pin vise and small diameter drill bits.
- Cutting and bending tools for music wire.

## 1.3 Adhesives

Adhesives are many times a question of personal preference and/or what is available. We use a variety of different adhesives when building the MXS; here are some guidelines as to what we do.

- Most foam to foam assembly is done using Ultimate RC Foam Glue or UHU Creativ for Styrofoam. This type of glue excels in bond strength flexibility and light weight. Working with these glues requires good surface preparation and application techniques. In addition they do require additional drying time so patience is a must.
- Cyanoacrylates (CA) adhesives are used in certain areas when bonding foam to non foam components and joints are not high stress. In addition, where speed is desired or necessary CA is used. As a general rule of thumb we use only foam safe CA glue and foam safe activator. Activator is required for foam safe CA when bonding foam otherwise the adhesive will not cure. Wherever possible apply the CA adhesive to the small component to be bonded and spray activator to the mating surface, then join the parts. If this is not possible align the parts and place CA adhesive to the joint, when held in position spray activator around the edges to initiate the curing process. Regular CA is used in a few assemblies when made separate to the airframe, these are primarily the pushrods and the landing gear axles.
- Epoxy is used in all high stress areas and when bonding carbon doublers to foam. In addition, a mixture of epoxy and micro balloons is used when forming the wing fillets. Be careful when deciding which type of epoxy to mix (5-6 minute vs. 30 minute) as you don't want to run out of work time. The instructions will give recommendations as to which type to use.

Other adhesives can be used for assembly and are mainly a question of personal preference. Remember, adhesives listed in this manual are recommendations and if you have different experiences you may substitute your own choice.

## 2 Parts List

The following is a list of all the parts that will be used for the build. This list outlines the Depron Foam, Plywood and Carbon parts. For additional hardware please see Chapter 1.

### 2.1 3 MM Depron Parts, Foam Sheet A

- A1 Ailerons (2)
- A2 Rudder
- A3 Vertical Stabilizer
- A4 Fuselage Front Bottom
- A5 Horizontal Stabilizer
- A6 Elevator
- A7 Wheel Pant Centers (2)
- A8 Wheel Pant Right Side (2)
- A9 Wheel Pant Left Side (2)
- AD1L – AD11L Left Fuselage Doublers
- AD1R – AD11R Right Fuselage Doublers
- AXX Scrap foam from Sheet A will be used to make wing tip caps as well as some miscellaneous doublers and hatch components.

### 2.2 6 MM Depron Parts, Foam Sheet B

- B1 Wing Spar
- B2 Main Fuselage Crutch Element
- B3 Wing Spar Front Crutch Element
- B4 Wing Spar Rear Crutch Element
- B5 Aileron Servo and Receiver Tray
- B6 Firewall
- B7 Landing Gear Bulkhead Top
- B8 Landing Gear Bulkhead Bottom
- B9 Rear Bulkhead
- B10 Wing Rib 1 Front (2)
- B11 Wing Rib 2 Front (2)
- B12 Wing Rib 3 Front (2)
- B13 Wing Rib 4 Front (2)
- B14 Wing Rib 1 Rear (2)
- B15 Wing Rib 2 Rear (2)
- B16 Wing Rib 3 Rear (2)
- B17 Wing Rib 4 Rear (2)
- B18 Wheel Pant Spacers (4)

## 2.3 2 MM Depron Parts, Foam Sheets C and D

- C1 Left Fuselage
- C2 Right Fuselage
- C3 Fuselage Front Top and Battery Hatch
- C4 Cockpit Filler
- C5 Fuselage Bottom and Radio Compartment Hatch
- C6 Landing Gear Bulkhead Top Front Doubler
- C7 Landing Gear Bulkhead Bottom Front Doubler
- C8 Landing Gear Bulkhead Top Rear Doubler
- C9 Landing Gear Bulkhead Bottom Rear Doubler
- D1 Right Wing Skin (2)
- D2 Left Wing Skin (2)

## 2.4 1/16" Plywood Parts, Sheet E

- E1 Firewall Front Doubler (Optional CF component)
- E2 Firewall Top Rear Doubler (Optional CF component)
- E3 Firewall Bottom Rear Doubler (Optional CF component)
- E4 Tail Wheel Bracket
- E5 Crutch assembly – servo mount reinforcement plates (2) (Optional CF component)
- E6 Landing Gear Mount Cross Element (2)
- E7 Landing Gear Mount Cross Element Spacer
- E8 Landing Gear Bulkhead Front Doubler
- E9 Landing Gear Bulkhead Rear Doubler
- E10 Landing Gear Fuselage Doublers (2) (Optional CF component)
- E11 Control Horns (4)
- E12 Wheel Pant Brackets (4)

## 2.5 Carbon Parts

Note: The length of these components is given here for reference purposes only. Do not cut your components to these lengths! When the parts are required, mark the actual length to be cut by laying the part in the position where it will end up.

- CF1 Spar Element, 6mm x 1mm Strip x 37" (2)
- CF2 Wing Front Alignment Pin, 4mm x 3mm Round Tube x 3"
- CF3 Wing Rear Alignment Pin, 6mm x 1mm Strip x 3"
- CF4 Wing Leading Edge Doubler, 4mm x 3mm Round Tube x 17" (2)
- CF5 Wing Trailing Edge Doubler, 3mm x 0.5mm Strip x 17 ¼"
- CF6 Aileron Torque Rods, 3mm x 2mm Square Tube x 17.64" (2)
- CF7 Aileron Reinforcements, 3mm x 0.5mm Strip x 2.84" (4)
- CF8 Horizontal Stabilizer Reinforcement, 3mm x 0.5mm Strip X 8.98"
- CF9 Elevator Cross Reinforcement, 3mm x 0.5mm Strip x 10.85"
- CF10 Elevator Tip Reinforcements, 3mm x 0.5mm Strip x 3.54" (2)

- CF11 Vertical Stabilizer Reinforcement, 3mm x 0.5mm Strip x 5.26"
- CF12 Rudder Bottom Reinforcement, 3mm x 0.5mm Strip x 2.92"
- CF13 Rudder Top Reinforcement, 3mm x 0.5mm Strip x 3.32"
- CF14 Radio Hatch Reinforcements, 3mm x 0.5mm Strip x 5" (2)
- CF15 Battery Hatch Reinforcements, 3mm x 0.5mm Strip x 6.92" (2)
- CF16 Aileron Push Rods, 2.1mm Rod x 6" (2)
- CF17 Elevator Push Rod, 2.1mm Rod x 3.55"
- CF18 Rudder Push Rod, 2.1mm Rod x 6.4"

### 3 General Assembly Reference

The following diagram shows a sectional view of the MXS fuselage. This can be used as a reference for the locations and geometries of the different components during assembly.

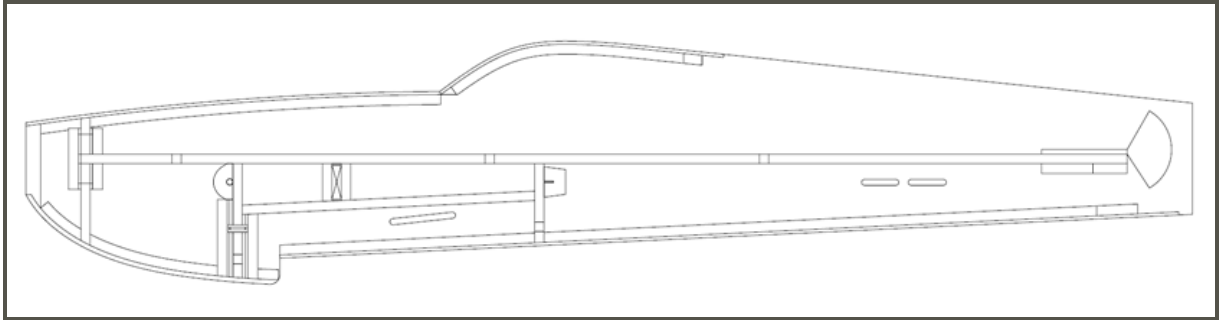

*Figure 2 - General Fuselage Assembly Reference*

## 4 Wing Skins and Wing Spar

### 4.1 Cut Out Sheet D Components

Cut out the wing skins from 2mm Depron Foam Sheet D.

Remember to make a small mark on them for the position of the spar (denoted by the dotted line) so that the wing can be aligned properly when assembling to the spar and body.

### 4.2 Tape and Glue Wing Skins and Leading Edge Reinforcements

The first step in making the wings is to glue together two halves of the wing skin. Although there is no distinction between the left and the right wing you can make the mistake of gluing the wrong side of the skins together. The wing skins will be glued at the leading edge during this step. The following diagram shows the correct way to glue the skins.

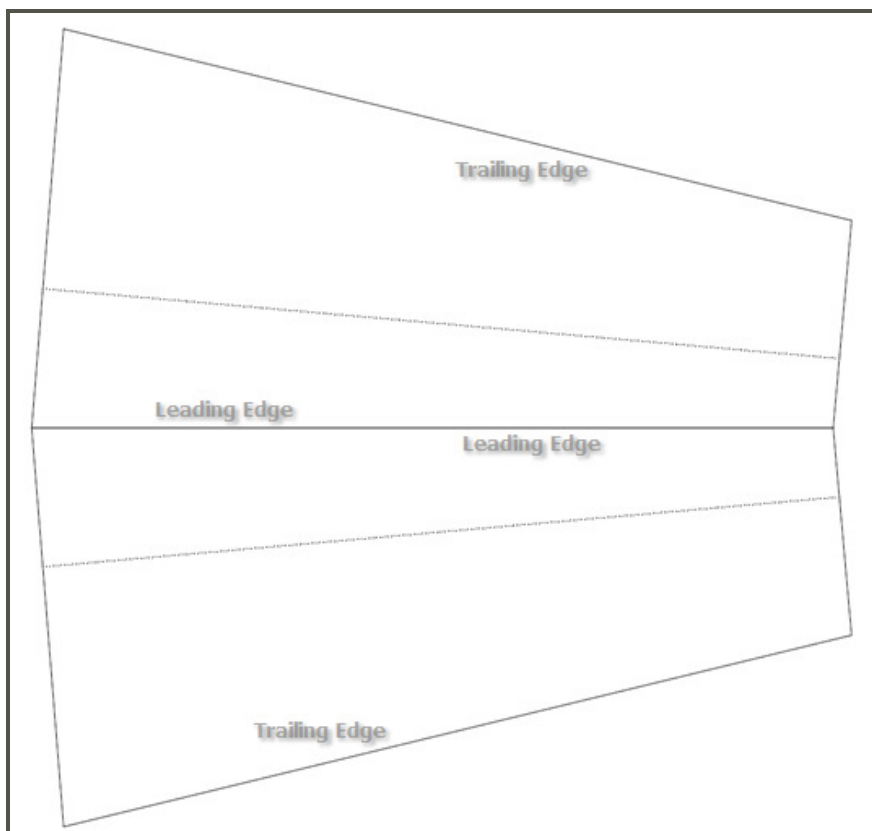

Figure 3 - Wing Skins Alignment Diagram

Note also the gap we need to leave in the leading edge reinforcement piece, this will leave the necessary space for the wing alignment pint that is attached to the fuselage.

**Parts Required**

- D1 Right Wing Skins (2)
- D2 Left Wing Skins (2)
- CF4 Wing Leading Edge Doubler, 4mm x 3mm Round Tube x 17" (2)
- Packing Tape
- 30 Minute Epoxy

**Procedure**

- Lay one left and one right wing skin on a table with the shiny side up and the two leading edges against each other. Make sure that they are perfectly aligned and tight against each other as any misalignment will be magnified when the wing skins are folded over.
- Join both halves together with a section of packing tape. Make sure that the tape is centered and that there are no wrinkles as this will be the leading edge of the wing. *Tip: cut the tape long, attach one end to the work surface, align the foam pieces under the stretched out tape and then press the opposite end to the work surface; work from the center of the piece of tape to the outside and smooth it out. For an extra strong bond you may want to activate the adhesive on the tape with a covering iron; make sure that the temperature is not set so hot that it will melt the foam.*
- Flip the wing over. Run the edge of the carbon leading edge doubler along the line where the two wing skins come together to form a shallow groove. The doubler will sit in this groove when attached. Note: that the doubler goes from the edge of the outboard end of the wing to about ½" from the inboard end; it is important to leave this space for the wing alignment pin.
- Rough up the carbon leading edge doubler with some sand paper for a better bond (don't breathe the dust!!!). Clean it thoroughly with rubbing alcohol to make sure that there is no dust left on it before gluing.
- Once both wings are ready for gluing mix up a batch of 30 minute epoxy. Fold the wing over backward at the tape joint and make sure that you get enough glue in the gap between the two wing skins. Unfold the wing and place tape side down on a flat surface. There should be some glue squeeze out from the joint, if more glue is necessary apply it to the groove you created by running the carbon leading edge doubler along the foam. Place the carbon leading edge doubler in place and hold it in position firmly while the glue dries (remember to leave the inboard gap!); this can be done with some wax paper and some weights or with some low tack masking or painters tape (the epoxy will not stick to the glue side, figure that). Repeat the process for the other wing.
- Once the wings are dry you can set them aside, we will not need them for a while.

### 4.3 Cut Out Sheet B Components

Cut out all the components from the 6mm Depron Foam Sheet B.

Note: when cutting out parts 2 and 5 the servo cutouts are dimensions for Futaba S3111 and S3114 servos. If you are going to be using different servos make sure that you cut out the servo openings to suit your servos.

Also note, the plans show plywood sheet E as an inset to sheet B, these components don't need to be cut from sheet B and are placed there only so that scale is preserved. Remove that section of the sheet before spraying removable adhesive and placing the paper on the foam for cutting.

Make sure you mark all reference points before removing the paper.

### 4.4 Glue Spar

We will now assemble the spar and set it aside for later.

#### **Parts Required**

B1 Wing Spar  
CF1 Spar Element, 6mm x 1mm Strip x 37" (2)  
30 Minute Epoxy

#### **Procedure**

- Rough up one side of each of the carbon spar elements with some sand paper for a better bond (don't breathe the dust!!!). Clean them thoroughly with rubbing alcohol to make sure that there is no dust left on them before gluing.
- Glue a carbon spar element to the top and one to the bottom of the spar using 30 minute epoxy. *Tip: Starting from the center tape both strips of carbon to the foam spar using low tack painters or masking tape. Work toward the outside of the spar and make sure that you don't induce any bends in the spar; it should be perfectly straight in both orientations.*
- Once the spar is dry you can set it aside, we will not need it for a while.

**This completes the Wing Skins and Wing Spar assembly**

## 5 Crutch Assembly

### 5.1 Assemble Firewall

The first step putting together the crutch assembly is to assemble the firewall.

#### **Parts Required**

B6	Firewall
E1	Firewall Front Doubler
E2	Firewall Top Rear Doubler
E3	Firewall Bottom Rear Doubler
	Engine mounting bolts (for clamping and alignment)
	5 Minute Epoxy

#### **Procedure**

- If you are using carbon fiber firewall doublers roughen one side of each element with some sand paper for a better bond (don't breathe the dust!!!). Clean them thoroughly with rubbing alcohol to make sure that there is no dust left on them before gluing.
- Make sure that the holes in your firewall doublers are drilled to the correct hole pattern to match your motor (the plans are laid out for the Hacker A20).
- Line up the front doubler with the firewall using the lateral tabs for correct vertical alignment; hold it or fix it in position with some low tack tape. Using a manual drill (such as a pin vise) drill the holes in the Depron firewall using the holes in the doubler as a guide.
- Glue the doublers onto the Depron firewall using 5 minute epoxy. Hold the doublers in place with the bolts you will be using to mount the motor; this will ensure perfect alignment as well as holding the doublers in place while the glue sets. You may want to rub some petroleum jelly on the bolt assemblies so that they don't get bonded to the firewall.
- Clean up all excess epoxy with some rubbing alcohol. Clean extra carefully in the area between the two rear doublers (where the main fuselage crutch element will adhere) and on the sides of the firewall.

### 5.2 Cut Out Sheet C Components

Cut out all the components from the 2mm Depron Foam Sheet C.

Note: When cutting the fuselage lateral components (C1 and C2) you will see that the firewall alignment notches have two reference lines. If you plan to use 0.5mm carbon fiber reinforcements on the firewall use the inside lines (thinner firewall), if you plan to use 1/16" plywood reinforcements use the outside lines (thicker firewall). Of course, if you decide to use a different material or thickness

you can adjust accordingly. If you are not sure cut the opening smaller, you can always enlarge it later.

### 5.3 Assemble Landing Gear Bulkhead

The next bulkhead that will be assembled is the landing gear bulkhead. This is a very critical component of the airframe since it will be taking very high stresses during take-off and landing. There are several components that make up this assembly so make sure that they are all dry fitted and line up correctly before you apply any adhesives. Take care and take your time on this assembly!

#### Parts Required

B7	Landing Gear Bulkhead Top
B8	Landing Gear Bulkhead Bottom
C6	Landing Gear Bulkhead Top Front Doubler
C7	Landing Gear Bulkhead Bottom Front Doubler
C8	Landing Gear Bulkhead Top Rear Doubler
C9	Landing Gear Bulkhead Bottom Rear Doubler
E6	Landing Gear Mount Cross Element (2)
E7	Landing Gear Mount Cross Element Spacer
E8	Landing Gear Bulkhead Front Doubler
E9	Landing Gear Bulkhead Rear Doubler
	Ultimate RC Foam Glue or UHU Creativ
	Thin CA
	Foam Safe CA
	Kevlar Thread

#### Procedure

- Using Foam glue make two foam sandwiches, C6-B7-C8 (bottom aligned, see diagram below) and C7-B8-C9. Make sure that the parts are aligned correctly and set aside to dry.

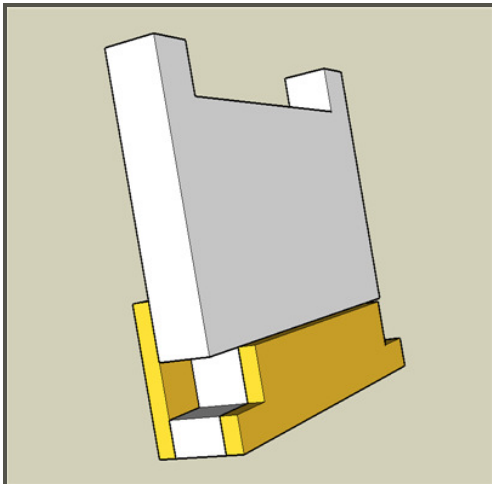

Figure 4 - Landing Gear Top Bulkhead Assembly

- As mentioned above, before you start gluing any plywood components of the landing gear assembly make sure that you dry fit all the components. If they don't fit correctly make any adjustments with needle files.
- Use CA to glue together the sandwich made up of E6-E7-E6 as shown in the diagram below. Make sure that the components line up correctly when gluing them. Once the assembly dries dry fit it again and make any necessary adjustments. This is also a good time to test the carbon fiber landing gear and make sure that the spacing between E8 and E9 matches the width of the gear elements. If the fit is too loose sand down the slots in the E6-E7-E6 sandwich, if it is too tight sand down the landing gear.

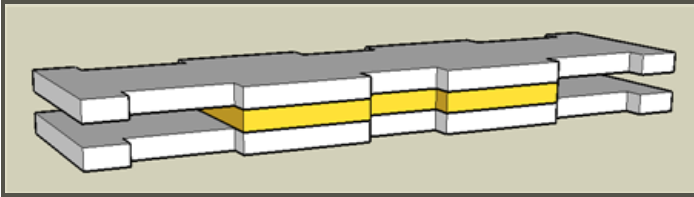

Figure 5 - Landing Gear Mount Center Sandwich

- Once the assembly has been dry-fitted it can be glued together. Use thin CA where the assembled parts come together making sure that they remain square as the glue dries. You want to make sure that the glue seeps into the plywood so that you don't create any bumps (make sure your glue is not too thick. Don't worry too much right now if the Kevlar reinforcement thread holes are clogged with glue, you will be drilling these out later. Make sure that you give the glue enough time to dry before you move on to the next step. The final plywood assembly should look like the following diagram.

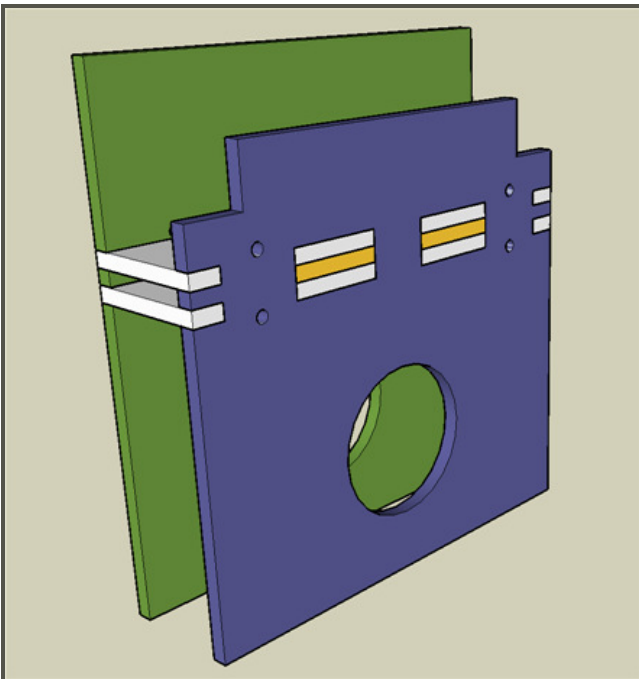

Figure 6 - Landing Gear Mount Completed Assembly

- Before continuing with this step, make sure that the foam assemblies have dried completely. You will notice that the foam assemblies are slightly thicker than the space available between the plywood components. Sand both sides of the foam assembly evenly until the thickness of the foam matches the space available. Clean the foam assemblies thoroughly with rubbing alcohol before gluing. Glue both foam elements to the plywood assembly using foam safe CA. Make sure that the sides line up correctly when doing this. *Tip: place the glue on the plywood components, spray the foam with accelerator and slip it into place making sure it's aligned correctly.*
- Using a manual drill or pin vise clear out the Kevlar reinforcement holes and drill through the foam. Make sure the holes are smooth since otherwise the Kevlar thread will snag as you sew on the reinforcements.
- Using a standard household needle and some Kevlar thread sew in two reinforcement loops (one on each side of the assembly). Start by placing the end of the thread close to the holes and attach with a small drop of foam safe CA. Once the glue is dry start feeding the holes in a circular pattern (try to get at least 10 wraps. Once the winding is complete soak both sides with foam safe CA making sure you get glue in the holes as well. Once the CA is dry trim off any excess thread. The landing gear bulkhead is now complete.

## 5.4 Assemble Servo Mount Reinforcements

Before final assembly we will add the main crutch element reinforcements and servo mounts.

### Parts Required

- B2 Main Fuselage Crutch Element
- E5 Crutch assembly – servo mount reinforcement plates (2)  
5 Minute Epoxy

### Procedure

- As with B2 When cutting out parts E5 make sure that they match the size of your selected servos.
- If you are using carbon fiber E5 reinforcement plates roughen up one side with some sand paper for better adhesion (make sure you make a top and a bottom). Clean the parts thoroughly with rubbing alcohol before assembly.
- Making sure that everything is aligned correctly glue the reinforcements to the crutch assembly using 5 minute epoxy.

## 5.5 Assemble Crutch

We will now do the final assembly of the fuselage crutch.

**Parts Required**

- Completed Firewall Assembly (B6)
- Completed Landing Gear Assembly (B7 & B8)
- Completed Main Fuselage Crutch Element (B2)
- B3 Wing Spar Front Crutch Element
- B4 Wing Spar Rear Crutch Element
- B5 Aileron Servo and Receiver Tray
- B9 Rear Bulkhead
- Foam Safe CA
- Ultimate RC Foam Glue

**Procedure**

- Using foam safe CA glue B5 to the Landing Gear Assembly (B7 & B8).
- In order to follow the left and right orientations laid out in this manual you will need to assemble the main crutch element with the following orientation. When viewing the main crutch element from the top (opposite side from the aileron servo/receiver tray) the rear servo cutout (elevator servo) needs to be on the right side of the fuselage. Remember that you will work on the fuselage and crutch upside down at several times so make sure you don't get confused.
- Assemble the rest of the crutch using Ultimate RC Foam Glue using the following picture for reference (note, this picture is from the crutch assembly of the original prototype and does not incorporate all the updated design elements to the main crutch element, firewall bulkhead and landing gear bulkhead. The general geometry of the crutch has not changed however so it can be used as reference for the position of the parts).

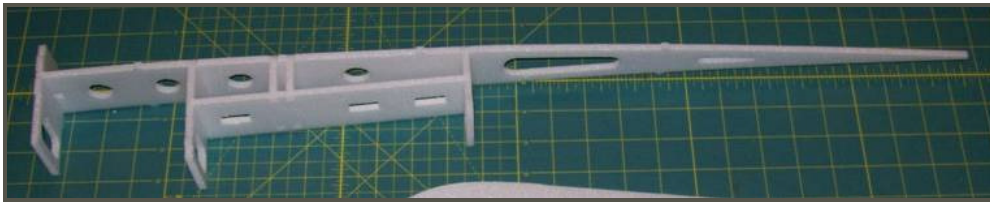

Figure 7 - Crutch Assembly Geometry

**This completes the Crutch assembly**

## 6 Fuselage Sides

### 6.1 Cut Out Sheet A Components

Cut out all the components from the 3mm Depron Foam Sheet A. *Note: Do not remove the paper off the ailerons at this time, do it after next section has been completed.*

### 6.2 Doubler Layout and Alignment Information

#### 6.2.1 Cutting Layout Information

The following is a layout key to the doubler components AD1L to AD11L and AD1R to AD11R on foam sheet A (L are fuselage left side components and R are fuselage Right Side Components). This key should be used to identify which components you are cutting out.

AD1	Front Wing Alignment Pin Doubler
AD2	Rear Wing Alignment Pin Doubler
<b>AD3</b>	<b>Crutch Rear Support Doubler</b>
<b>AD4</b>	<b>Bottom Rear Doubler</b>
AD5	Bottom Center Doubler
AD6	Nose Rear Doubler
AD7	Nose Center Doubler
AD8	Nose Front Doubler
AD9	Top Front Doubler
AD10	Battery Hatch Doubler
<b>AD11</b>	<b>Canopy Doubler</b>

Note that the doublers highlighted in **blue** have different lengths on the left and the right side of the fuselage (for clearance purposes). Although it is not critical on which side they are glued to you need to make sure that the fronts of the doublers are aligned to the front reference marks; if these doubler are glued to far back the fuselage will not “close” properly.

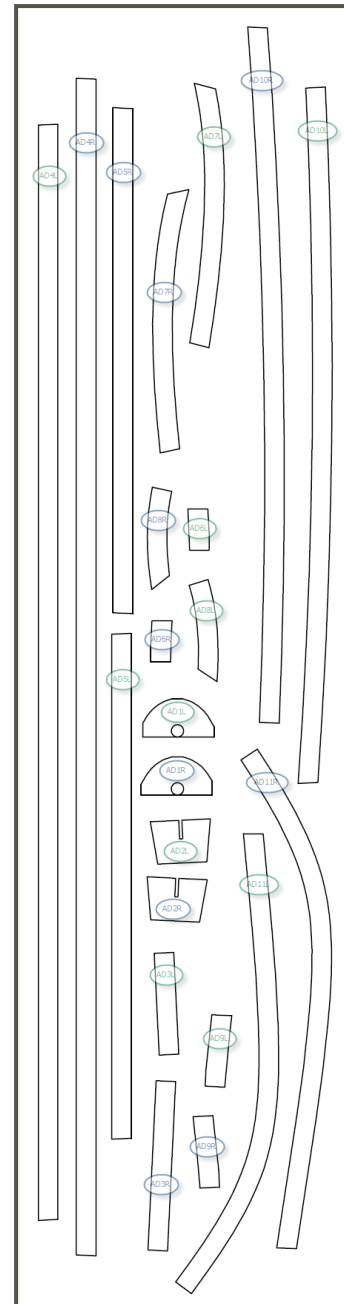

Figure 8 – Doubler Layout

### 6.2.2 Placement Layout Information

The following diagram shows the placement of the fuselage doublers on the fuselage sides (you are looking at the inside of the sides unless you are reversing left and right).

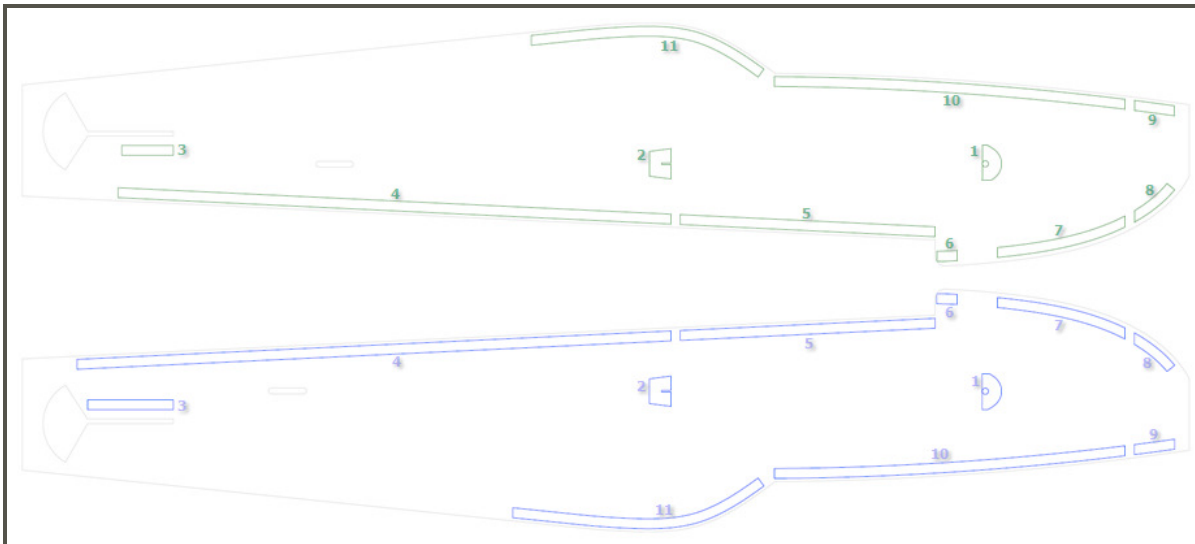

Figure 9 - Doubler Placement

### 6.2.3 Gap Alignment Information

The fuselage doublers have different gap requirements to the edges where they are glued. The following table references the gap requirements for the doublers. It is recommended that you use some scrap pieces of 2mm, 3mm and 6mm Depron to ensure that doublers are glued correctly by using them as reference guides to the edges.

Doubler	Gap Reference	Key
AD1	No Gap	<b>2mm Gap</b> <b>3mm Gap</b> <b>6mm Gap</b>
AD2	No Gap	
AD3	<b>6mm from stabilizer slot (proper spacing is provided by the crutch)</b>	
AD4	<b>2mm from fuselage edge</b>	
AD5	<b>2mm from fuselage edge</b>	
AD6	<b>3mm from fuselage edge</b>	
AD7	<b>3mm from fuselage edge</b>	
AD8	<b>3mm from fuselage edge</b>	
AD9	<b>2mm from fuselage edge</b>	
AD10	<b>2mm from fuselage edge</b>	
AD11	<b>2mm from fuselage edge</b>	

Table 1 - Gap Alignment Information

## 6.3 Fuselage Side Assembly

In this step we will complete the assembly of the fuselage sides. When verifying left vs. right look at your crutch assembly, remember the rear cutout in the crutch assembly needs to match up to the rear servo arm clearance cutout in the fuselage side.

### Parts Required

C1 Left Fuselage  
C2 Right Fuselage  
ADXX Fuselage Doublers  
Ultimate RC Foam Glue

### Procedure

- Using the reference lines from the paper template crease the front inside of the fuselage sides with a blunt object (e.g. a dry ball point pen is good). This will make folding the fuselage nose easier when gluing the top and the bottom front pieces.
- The process to assemble the sides is the same for both sides. Assemble one side of the fuselage at a time. Lay down the crutch assembly for alignment purposes using the alignment notches in the crutch and the fuselage sides to ensure proper alignment. The rear of the crutch element needs to align with the bottom of the stabilizer cutout; you may want to use a scrap piece of 3mm Depron on the slot to ensure this. Place the wing alignment pins in position. Remember to use the correct Depron spacers to ensure the proper spacing away from the edges
- Using Ultimate RC Foam Glue and referencing the crutch element for alignment glue in components AD1, AD2, AD5, AD8, AD9 and AD10.
- Glue in component AD3 making sure that it sits flush with the crutch element and that the front is aligned with the front of the horizontal stabilizer cutout.
- Glue in component AD4 making sure that the front butts up with the rear crutch bulkhead.
- To allow space for the balsa triangle stock doublers AD6 and AD7 need to be glued  $\frac{1}{4}$ " away from the landing gear bulkhead plywood elements; glue them in this position.
- Make a mark on the fuselage side edge 0.325" (~8mm) rear of the corner made by the canopy and the fuselage. The front of the cockpit doubler AD11 needs to line up with this mark; glue it in position.

**This completes the Fuselage Sides**

## 7 Ailerons, Elevator and Rudder

### 7.1 Install Aileron Torque Rods

The following diagram shows the aileron assembly:

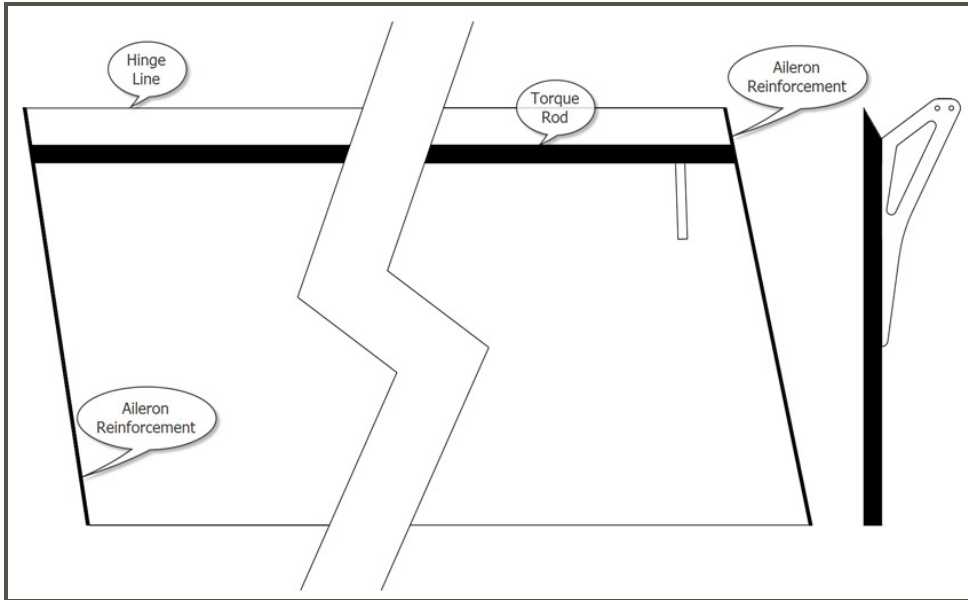

Figure 10 - Aileron Assembly

First step in making the ailerons is to install the torque rods; this will give the ailerons the necessary resistance to twisting across their full length.

#### Parts Required

- A1 Ailerons (2)
- CF6 Aileron Torque Rods, 3mm x 2mm Square Tube x 17.64" (2)
- 5 Minute Epoxy

#### Procedure

- The ailerons should by now have been cut out of 3mm Depron Sheet A but should still have the paper templates attached to them. First step is to mark the ailerons so that you can identify one from the other (it may be easier to set aside one until the other is completed. In addition, you will want to clearly identify one end from the other, a line on one end will help you line up the pieces you will separate when it comes time to join them again.
- Cut away the 3mm section that will be replaced by the torque rod; this section is marked by the cross hatch pattern on the paper template. A straightedge and a hobby knife with a sharp blade will be best here. The center section will be discarded. While the sections are separated now would be a good time to cut out the control horn slot (since the control horn will but up against the torque rod. Cut the control horn slot narrower than

the marks, this will ensure a press fit when you glue in the control horn and provided a sturdier bond and better alignment.

- Cut CF6 to length using the actual aileron for reference. You can try to cut the end angle on the torque rod or just cut it slightly proud and square and then sand the angles to match the shape of the aileron.
- Rough up the two sides of the carbon torque rod that will adhere to the foam with some sand paper for a better bond (don't breathe the dust!!!). Clean it thoroughly with rubbing alcohol to make sure that there is no dust left on it before gluing.
- Place the two aileron pieces and the torque rod in position on a flat surface and tape them tightly with some low tack masking tape. The best approach here is to use a full length strip of wide (2") masking tape. Flip the aileron over; if the pieces are not tight adjust the tape.
- With the tape on the bottom side and using it as a hinge unfold the assembly. Mix up the epoxy for one Aileron and work quickly. Spread it between the torque rod and the foam (it may be easier to fold back one joint at a time). Once the glue is in position lay the aileron on a flat surface tape down and make sure that the aileron is perfectly flat. Clean off any squeeze out with some rubbing alcohol. Once the surface is clean place another piece of tape on the top side making sure that the assembly is being held straight. Set the aileron aside to dry and repeat the process on the second aileron.

## 7.2 Attach Aileron Reinforcements

Next the ailerons will get reinforcements on either end.

### **Parts Required**

A1 Ailerons (2)  
 CF7 Aileron Reinforcements, 3mm x 0.5mm Strip x 2.84" (4)  
 5 Minute Epoxy

### **Procedure**

- Using the completed ailerons for reference cut a carbon aileron reinforcement for each end of each aileron.
- On one end of each aileron reinforcement cut or sand a 50 – 60 degree bevel.
- Lay out the reinforcements on the ailerons to make sure you make one left and one right aileron and that the bevels on both ends of the same aileron are oriented in the same direction. Rough up the side of the carbon aileron reinforcement that will adhere to the foam with some sand paper for a better bond (don't breathe the dust!!!). Clean it thoroughly with rubbing alcohol to make sure that there is no dust left on it before gluing.

- Using 5 Minute Epoxy to glue the reinforcements and tape to hold them in place attach them on to both ends of the aileron. Again, make sure you make one left and one right aileron and make sure that the ailerons are perfectly flat.

### 7.3 Bevel the Aileron Hinge Line and Attach the Control Horns

#### Parts Required

E11 Control Horns (2)  
 Aileron Assemblies (A1)  
 Foam Safe CA

#### Procedure

- Using the angles cut into the aileron reinforcements as a reference cut or sand a bevel into each one of the Ailerons.
- Glue the control horns onto the ailerons making sure that you glue them to the correct side. Ailerons will be hinged on top, control horns will go on the bottom.
- Set the ailerons aside for now, they are completed.

### 7.4 Rudder Reinforcements

First thing that needs to be done to the rudder is to install the carbon reinforcements. There are two reinforcements that go onto the rudder, the top and the bottom reinforcement. The bottom reinforcement will have to be beveled for the hinging of the rudder. When beveling the CF reinforcement and the rudder remember that you want the hinge line to be on the side of the rudder servo (left side if you followed the plans). The following diagram shows the locations of the rudder reinforcement strips:

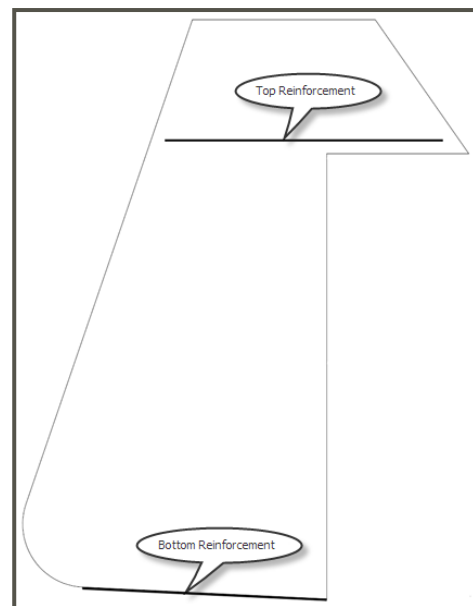

Figure 11 – Rudder Reinforcement Strips

#### Parts Required

A2 Rudder  
 CF12 Rudder Bottom Reinforcement, 3mm x 0.5mm Strip x 2.92"  
 CF13 Rudder Top Reinforcement, 3mm x 0.5mm Strip x 3.32"  
 5 Minute Epoxy

**Procedure**

- Cut a slot in the rudder at the location of the top reinforcement with one pass of a hobby knife. You don't have to worry about widening the slot; the carbon is thin enough to fit as is. Cut the top reinforcement to length and dry fit it in the slot to make sure it fits before you glue it.
- Rough up the two sides of the carbon reinforcement with some sand paper for a better bond (don't breathe the dust!!!). Clean it thoroughly with rubbing alcohol to make sure that there is no dust left on it before gluing.
- Glue the reinforcement with 5 minute epoxy making sure that both sides are thoroughly covered with glue (you may want to wait and glue both rudder reinforcements at the same time). If you don't get a positive bond here you will be weakening the top of the rudder and it may break off.
- If you are going to be applying decals that go above the reinforcement you are done with the top reinforcement. If you don't plan on applying decals you may want to reinforce both sides of this joint with some narrow hinge or packing tape
- The bottom rudder reinforcement spans the length of the rudder up to where the curve starts; there is no need to wrap the reinforcement around the curve. Cut the bottom reinforcement to length.
- Bevel one end of the bottom reinforcement with a small cut of a razor saw or some sand paper on a flat sanding surface. Since we will not be beveling the fuselage the bevel in the rudder will have to allow for the complete range of rudder throw. It is recommended that you bevel the rudder to at least 45° but for 3D rates you may want to bevel at around 60°.
- Rough up the correct side of the carbon reinforcement with some sand paper for a better bond (don't breathe the dust!!!). Clean it thoroughly with rubbing alcohol to make sure that there is no dust left on it before gluing.
- Glue the reinforcement on to the bottom of the rudder with some 5 minute epoxy.

**7.5 Bevel the Rudder Hinge Line and Attach the Control Horn****Parts Required**

- E11 Control Horn  
Rudder Assembly (A2)  
Foam Safe CA

**Procedure**

- Using the angles cut into the bottom reinforcement as a reference cut or sand a bevel into the rudder.

- Glue the control horn onto the rudder making sure that you glue it to the correct side (left if you are following the plans).
- Set the rudder aside for now, it is completed.

## 7.6 Elevator Reinforcements

First thing that needs to be done to the elevator is to install the carbon reinforcements. There are three reinforcements that go onto the elevator, the cross reinforcement and the two elevator tip reinforcement. The following diagram shows the locations of the rudder reinforcement strips:

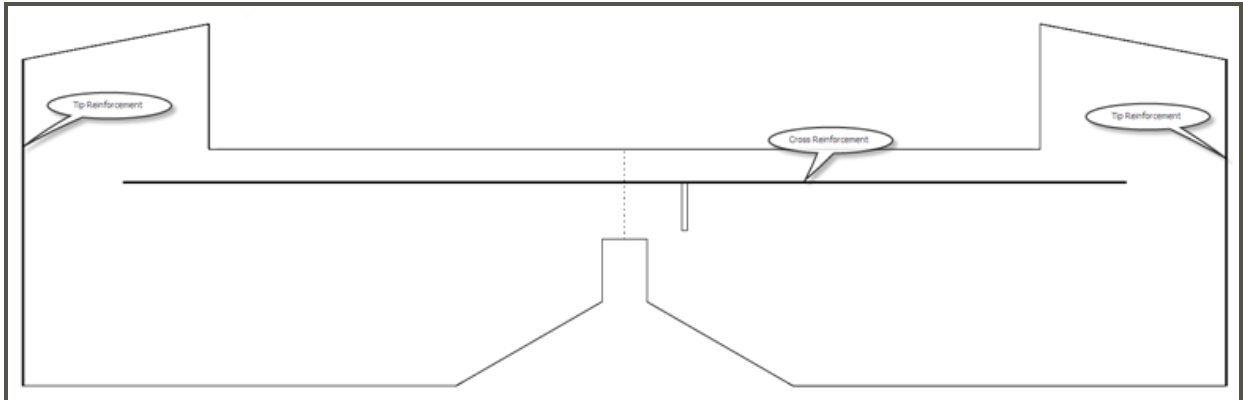

Figure 12 - Elevator Reinforcement Strips

### Parts Required

- A6 Elevator
- CF9 Elevator Cross Reinforcement, 3mm x 0.5mm Strip x 10.85"
- CF10 Elevator Tip Reinforcements, 3mm x 0.5mm Strip x 3.54" (2)
- 5 Minute Epoxy

### Procedure

- Cut a slot in the elevator for the cross reinforcement. The actual length of the slot is not that critical but it does need to but up to the control horn slot so that when the control horn is bonded in it is also bonded to the reinforcement. Cut the cross reinforcement to length and dry fit it in the slot to make sure it fits before you glue it. *Tip: although not strictly necessary, if you have 3mm X 1mm CF strip available you can use a piece here.*
- Rough up the two sides of the carbon reinforcement with some sand paper for a better bond (don't breathe the dust!!!). Clean it thoroughly with rubbing alcohol to make sure that there is no dust left on it before gluing.
- Glue the reinforcement with 5 minute epoxy making sure that both sides are thoroughly covered with glue (you may want to wait and glue all the elevator reinforcements at the same time).
- Cut the elevator tip reinforcements to length using the elevator for reference.

- Rough up one sides of the carbon reinforcements with some sand paper for a better bond (don't breathe the dust!!!). Clean them thoroughly with rubbing alcohol to make sure that there is no dust left on them before gluing.
- Glue the reinforcements on to the elevator tips with some 5 minute epoxy.

## 7.7 Horizontal Stabilizer Final Assembly

The elevator hinge line will go on top; the control horn will be on the bottom.

### Parts Required

A5 Horizontal Stabilizer  
E11 Control Horn  
Elevator Assembly (A6)  
Foam Safe CA

### Procedure

- Cut or sand a bevel into the bottom of the elevator.
- Hinge the elevator to the horizontal stabilizer using your favorite hinging method. *Tip: we like to use 3M Blendederm tape for our hinges. We use 1" width for the MXS and first place a strip on the top side centered on the hinge line with the elevator fully deflected downward. Once this is attached we fold the elevator back on itself and attach a piece to the opposite side making sure that it is completely bonded to the inside of the bevel. Finally we activate the glue with a covering iron set at a low temperature setting (don't melt your foam!) to get an extra strong bond.*
- Glue the control horn onto the bottom side of the elevator.
- Set the horizontal stabilizer assembly aside for now, it is completed.

**This completes the Ailerons, Elevator and Rudder**

## 8 Fuselage Assembly (Stage 1)

The first stage of the fuselage assembly will be joining the two fuselage halves, the crutch assembly and the vertical stabilizer. Later on, in stage 2, we will add all the top and bottom pieces to close up the fuselage.

### 8.1 Bevel Fuselage Sides and Horizontal Stabilizer

We need to sand some bevels onto the fuselage sides and onto the vertical stabilizer. It will be much easier to accomplish this before we join the fuselage halves as later there access to the surfaces will be difficult. The following diagram shows the areas that need to be beveled on the fuselage sides:

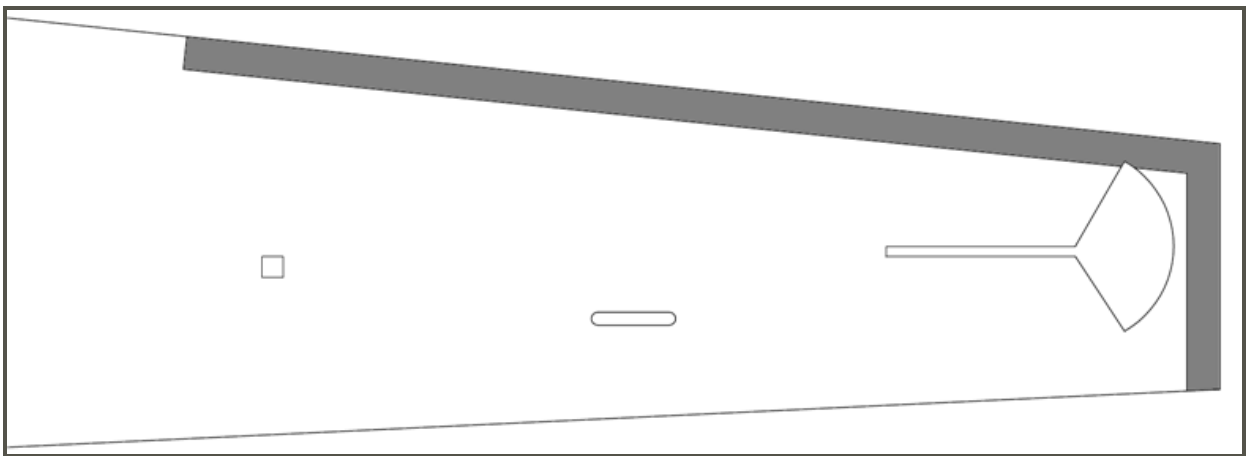

Figure 13 - Fuselage Beveling Reference

The following diagram shows the areas that need to be beveled on the vertical stabilizer (A3):

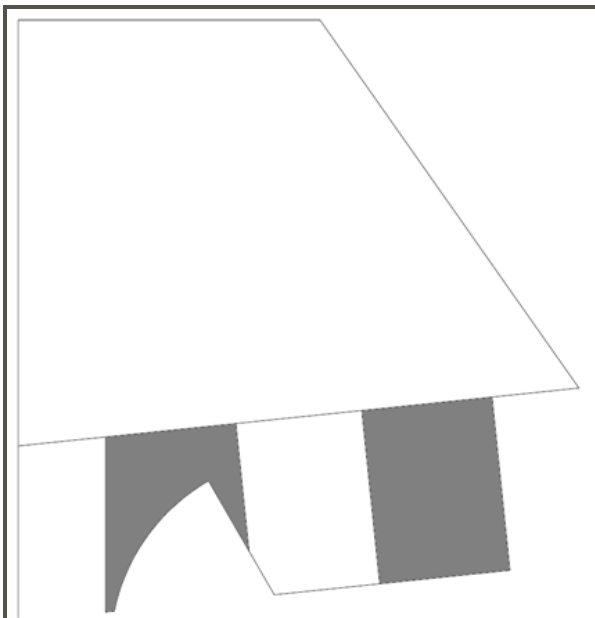

Figure 14 - Vertical Stabilizer Beveling Reference

**Parts Required**

- Left Fuselage Assembly (C1)
- Right Fuselage Assembly (C2)
- A3 Vertical Stabilizer

**Procedure**

- Using the cockpit filler piece (C4) dry fitted onto the fuselage sides (one at a time) mark the rearmost point that it reaches; this will be the reference for the front of the bevel.
- Using sandpaper affixed to a flat sanding block, sand a slight bevel along the fuselage sides (C1 & C2) in the area marked in gray in *Figure 13*. The objective here is to increase the bonding area without making the resulting sides too thin. For the top you are aiming for a bevel that will reduce the edge of the fuselage from 2mm to 1mm gaining about ½" to ¾" in depth. For the rear of the fuselage you will sand slightly less, you need to reduce the thickness from 2mm to 1.5mm gaining about ¼" to ½" in depth.
- Again, using sand paper affixed to a flat sanding block, sand bevels in the front and the rear of the vertical stabilizer (A3) in the areas marked in gray in *Figure 14*. Sand evenly on both sides trying to thin down the front and rear to a fairly narrow profile (less than ½mm).

**8.2 Fuselage Glue-up, step 1**

If you look closely at the fuselage crutch assembly (B2) you will notice that there is a slight angle to the sides just rear of the rear wing alignment pin. The first part of the glue up will be the front half of the fuselage using this as the point of reference.

**Parts Required**

- Crutch Assembly (B2)
- Fuselage Sides (C1 & C2)
- ¼" balsa triangle stock
- Ultimate RC Foam Glue
- Foam Safe CA
- 5 Minute Epoxy

**Procedure**

- The first step in the glue up is to attach both sides of the fuselage to the crutch front half of the crutch assembly. The crutch assembly should slot in to the cutouts in the fuselage side for correct alignment. If you are using a plywood firewall and did not cut the wide slots in the fuselage sides enlarge the slots now. Do a dry fit of the assembly before applying any glue to make sure that everything lines up correctly and make any final adjustments. If you want to use a Velcro strap to retain the battery now would be the best time

to install it, simply place it in the slots provided right behind the spar reinforcement in the crutch assembly.

- This assembly should be done on a flat surface. Lay one side of the fuselage down with the doublers facing up. Apply Ultimate RC Foam Glue to the foam components on both sides of the **FRONT** of the crutch assembly. Place it on the fuselage side making sure that all the alignment tabs slot in correctly. Place the other fuselage side on top of the crutch assembly again making sure that everything slots in correctly. Place some medium weights on the fuselage evenly distributed along the length of the front half.
- Once the foam glue has dried reinforce the edges of any plywood and carbon fiber components using thin or medium Foam Safe CA. Don't build up the glue to thick since both the landing gear bulkhead and the firewall will be receiving ¼" balsa triangle stock doublers.
- Cut ¼" balsa wood triangle stock doublers for the front and rear of both the landing gear bulkhead as well as the firewall. There should be a total of 10 doublers. Glue the doublers in with 5-minute epoxy (alternately you can use foam safe CA for this step). See the following diagram for exact doubler locations:

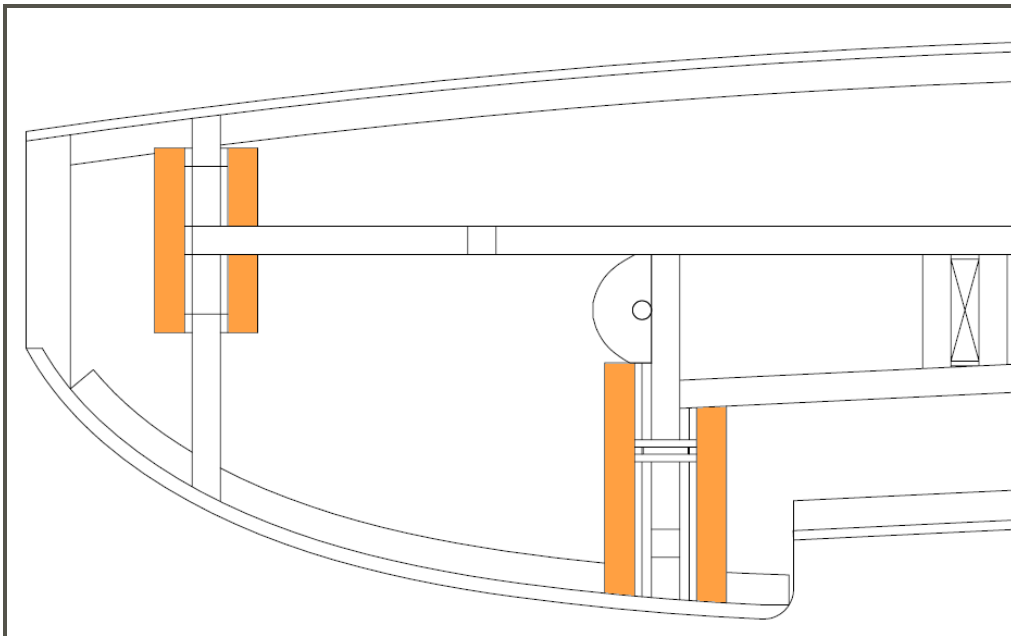

Figure 15 - Balsa Doubler Locations

### 8.3 Fuselage Glue-up, step 2

Here we will glue together the rear of the fuselage including the vertical stabilizer.

#### Parts Required

- Fuselage Assembly
- A3 Vertical Stabilizer

## Ultimate RC Foam Glue

**Procedure**

- It is important here to do a dry fit to understand your clamping strategy when joining the rear of the fuselage since this is the key to a straight and true airplane. You will need to press the sides of the fuselage in against the crutch assembly; some low tack tape top and bottom will work well here. You will need cauls and clamps to hold the rear of the fuselage together. You will need a narrow clamp and some scrap foam to press the fuselage around the front of the vertical stabilizer. Finally, you will need a scrap piece of 3 mm foam to place in the horizontal stabilizer slot to make sure that the rear crutch assembly aligns correctly at the rear of the fuselage.
- Apply Ultimate RC Foam Glue along the edges of the clutch assembly making sure that you get glue all the way up to the place where the front of the crutch assembly is adhered. Apply glue to one side of the beveled rear edge of the fuselage (not the rear top [turtle deck], we will glue that together after the running gear has been installed). Apply glue to both sides of the vertical stabilizer where it will fit inside the fuselage. Clamp the whole assembly together. Place a piece of low tack masking tape over the top of the rear fuselage (turtle deck) immediately in front of the vertical stabilizer holding the top of the two fuselage sides together. Leave this piece of tape in place until the entire top rear fuselage has been glued together. This will reduce the stress at the front of the vertical stabilizer during assembly and avoid it coming unglued.
- Sight down the length of the fuselage to make sure that it is perfectly straight, if it is not make any necessary adjustments now.

**8.4 Empennage Assembly**

We will complete the first stage of the fuselage assembly by completing the empennage. This will allow us to install all the rear radio gear before we close up the fuselage.

**Parts Required**

Fuselage Assembly  
 Elevator Assembly (A5 & A6)  
 1/4" balsa triangle stock  
 CF11 Vertical Stabilizer Reinforcement, 3mm x 0.5mm Strip x 5.26"  
 Ultimate RC Foam Glue  
 Foam Safe CA  
 5 Minute Epoxy

**Procedure**

- The first step will be to install the elevator assembly onto the fuselage. In order to install it we will need to cut a slit at the rear end of the fuselage

opposite the horizontal stabilizer slot using a sharp hobby knife. Apply Ultimate RC Foam Glue to the fuselage where the horizontal stabilizer will fit making sure you cover all available surfaces (including the crutch assembly). Carefully open the fuselage at the location of the slit and slide the elevator assembly through it and seat it in the slot. Measure the distance from both edges of the elevator to a central reference point in the front of the fuselage to make sure that it's perfectly square. Make sure that the elevator is perfectly perpendicular to the fuselage (parallel to the ground). Make sure that the elevator moves smoothly in both directions.

- Once the elevator assembly has been glued in place add two reinforcements of 1/4" balsa triangle stock to the bottom of the horizontal stabilizer using Foam Safe CA. Taper the front and back of these reinforcements towards the 90 corner as shown in the following picture:



*Figure 16 - Horizontal Stabilizer Balsa Doubler Detail*

- Once the horizontal stabilizer has been attached make glue together the slot you cut in the rear of the fuselage using Ultimate RC Foam Glue. You may want to reinforce this joint with a small amount of packing or hinge tape but this is not strictly necessary.
- Using the rear edge of the fuselage and vertical stabilizer as a reference point mark and cut the vertical stabilizer reinforcement carbon fiber strip (CF11); this piece should cover the entire height of the rear of the plane as shown in the following diagram:

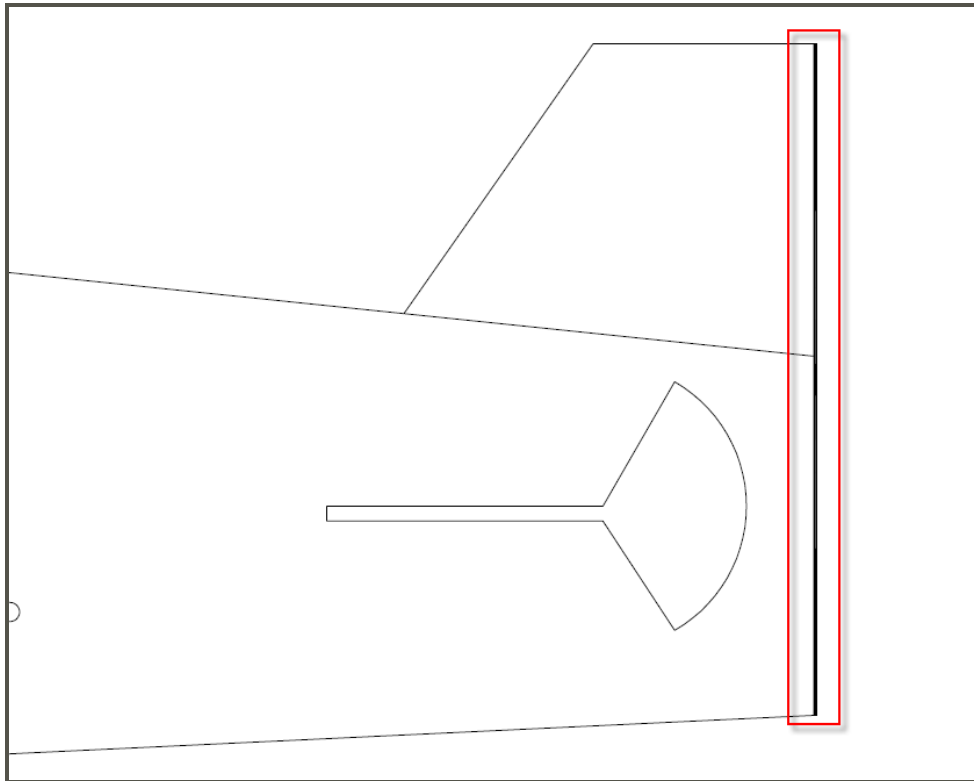

Figure 17 - Vertical Stabilizer Carbon Fiber Reinforcement

- Sand one side of the CF reinforcement to insure good adhesion. Clean all surfaces thoroughly and adhere the reinforcement to the fuselage with 5 Minute Epoxy.

**This completes the first stage of the Fuselage Assembly**

## 9 Power and Radio Gear installation

Recommended placement of the running gear is illustrated in the following diagram; you may find your setup slightly different:

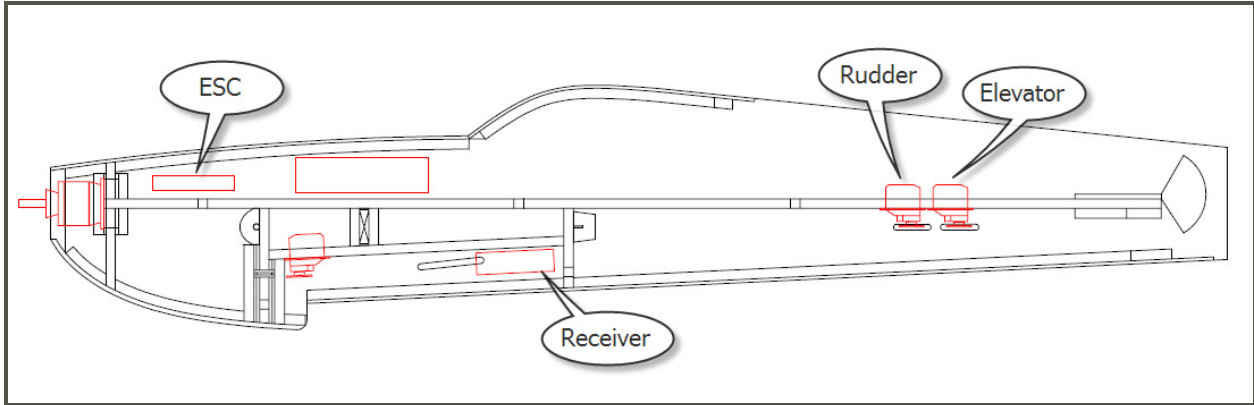

Figure 18 - Running Gear Placement Reference

You can use the position of the ESC and the receiver to fine tune the CG position; this will allow you to place the battery as close to wing spar (or CG) as possible. This CG location will allow you to use different capacity batteries without affecting the airplane's balance.

### 9.1 Mount Servos

First step in the installation of the running gear is to install the servos. You can use your favorite method to attach the servos but here we will outline the installation using hot melt glue.

#### Parts Required

Fuselage Assembly  
Servos  
Hot Melt Glue

#### Procedure

- Dry fit the servos in their respective location making sure that the fit is snug. If the fit is too loose you may want to consider wrapping the servos with tape to make the fit tighter.
- Note the orientation of the servos. The aileron servo has the control horn oriented towards the front of the airframe. The rudder and elevator servos have the control horn oriented towards the rear of the airframe.
- We mount servos with a shot of hot glue under each of the tabs. Place the servos in their slots about 1/4" above the final position. Place a medium drop of hot glue **UNDER** each of the two servo tabs. While the hot glue is still soft press the servo down into the slot. Make sure that some of the glue squeezes

through the mounting hole creating a “mushroom” shape as shown in the picture below:

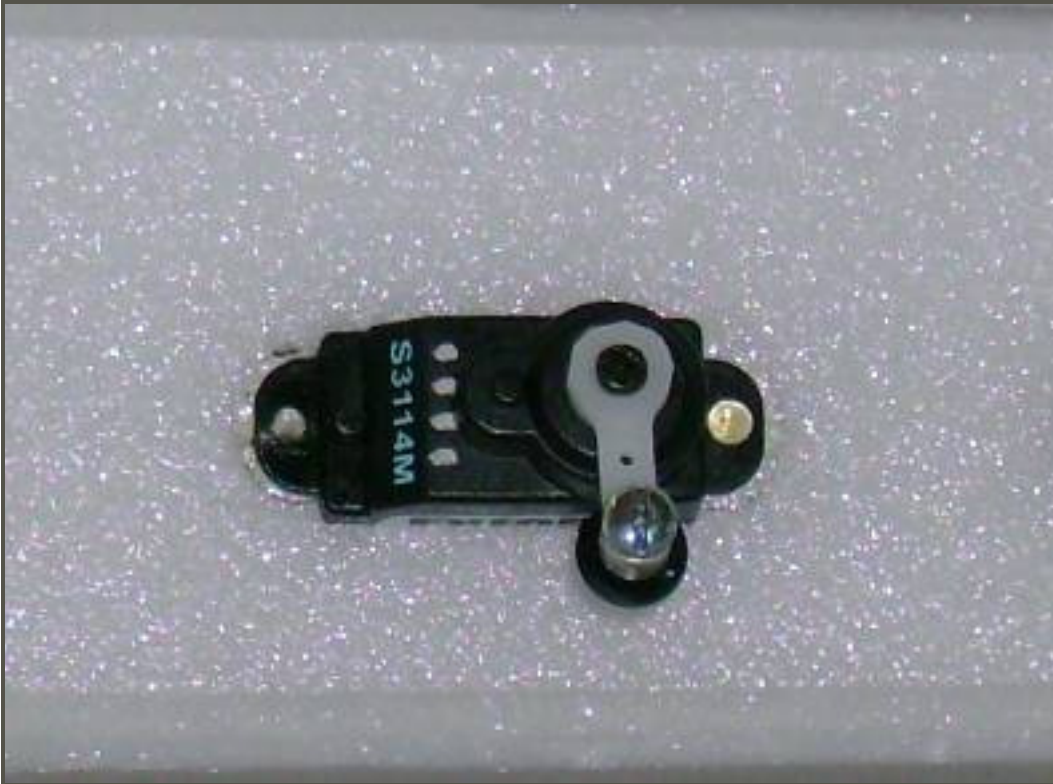

Figure 19 - Servo Mounting Example

## 9.2 Mount Motor

A general recommendation whenever mounting drive-train components that involve screws make sure that you use some kind of thread locking mechanism (lock nuts or thread locking compound for example).

### **Parts Required**

Fuselage Assembly  
Motor  
Mounting Bolts and Nuts

### **Procedure**

- Bolt the motor to the firewall with the wires oriented towards the top of the airplane using your preferred mounting method. We mount our motors with Allen bolts, washers and lock nuts.

## 9.3 Mount ESC and Receiver

### **Parts Required**

Fuselage Assembly  
ESC

Receiver

Double Stick Tape or Self Adhesive Velcro

**Procedure**

- Install ESC and Receiver in your chosen positions using double stick tape or self adhesive Velcro (hook and loop) strips. If you feel that you will want to fine tune the CG position using these components we recommend that you mount these components using Velcro.
- Connect and test all your electronics at this time. It will be easier to run the wires and to make any changes necessary before you close up the fuselage.
- Center all Servos and install all control arms on the servos, particularly the rudder and elevator servos, since access to them later will be much more constrained. Now would also be a good time to add any pushrod connectors to the servo control horns.

**This completes the installation of the Running Gear**

## 10 Fuselage Assembly (Stage 2)

Now that all the running gear is installed and connected we will close up the fuselage.

### 10.1 Attach Wing Alignment Pins

Before we close the fuselage we will glue in the wing alignment pins; this way we will be able to apply glue to the inside of the fuselage.

#### **Parts Required**

Fuselage Assembly  
CF2 Wing Front Alignment Pin, 4mm x 3mm Round Tube x 3"  
CF3 Wing Rear Alignment Pin, 6mm x 1mm Strip x 3"  
Foam Safe CA

#### **Procedure**

- Place the pins in their corresponding locations making sure they are correctly centered.
- Attach them to the fuselage using Foam Safe CA on the inside of the fuselage. Glue to both the fuselage sides and the vertical bulkheads.

### 10.2 Close Fuselage Rear Top

The first step in closing up the fuselage is to close the turtle deck and install the canopy filler piece.

#### **Parts Required**

Fuselage Assembly  
C4 Cockpit Filler  
Scrap 6mm Depron  
Packing Tape  
Ultimate RC Foam Glue

#### **Procedure**

- Using the following diagram as reference create a latch lock reinforcement piece out of scarp 6mm Depron to be mounted under the front of the canopy filler piece:

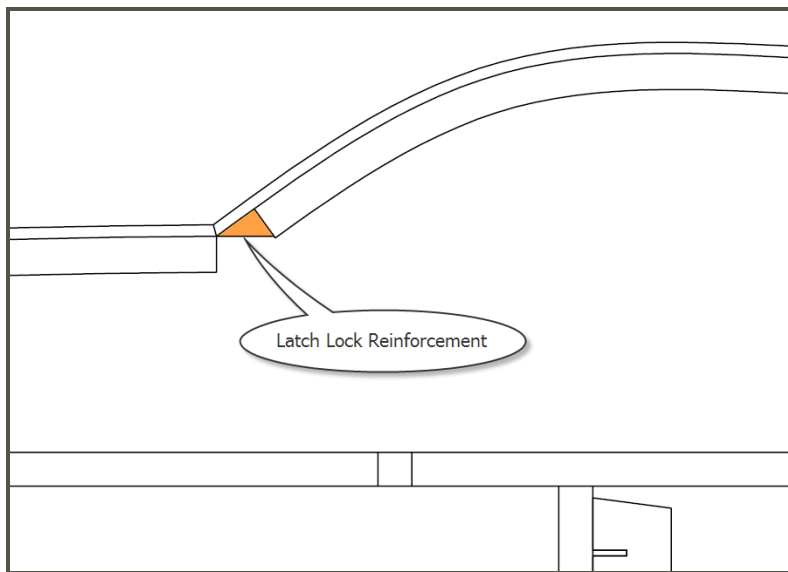

Figure 20 - Latch Lock Reinforcement Doubler

This piece needs to be the same width as the canopy filler. If there is any interference with the Canopy Doublers (AD11) just trim the doublers back accordingly. The bottom of the piece should follow the same lines as the front of the fuselage to give the battery hatch a flat reference surface to latch against. Once complete glue the piece in position to the canopy filler piece using Ultimate RC Foam Glue.

- Starting with the front of the Canopy Filler piece work towards the rear of the fuselage closing up the top of the fuselage. It is easiest to apply glue to all the pieces first (including fuselage sides and doubler tops) and then close the fuselage up using low tack tape as a clamping mechanism.
- Once the glue has dried we like to reinforce the turtle deck with a piece of clear packing tape in the same way that the leading edge of the wing has been reinforced at the beginning of the assembly.

### 10.3 Close Fuselage Rear Bottom

Next we install the bottom center and rear of the fuselage.

#### Parts Required

- Fuselage Assembly
- C5 Fuselage Bottom and Radio Compartment Hatch
- Scrap 6mm Depron
- Ultimate RC Foam Glue

#### Procedure

- If you haven't done so yet, separate part C5, Fuselage Bottom and Radio Compartment Hatch into 3 sections using the reference lines provided. Only the front and rear of this piece will be glued to the fuselage.

- Due to the small size of the front of C5 we will be reinforcing it with a small scrap piece of 6mm Depron. This piece needs to be slightly narrower than C5 to clear the fuselage doublers and needs to be glued towards the front of the piece to allow space for the radio access hatch tab to fit. When done glue this to the front of C5.
- Starting from the rear dry fit the pieces of C5 using a small amount of low tack tape to get the alignment right.
- Again we will close the bottom of the fuselage starting from the front and working towards the rear. Start by gluing in the front piece of C5 (with the 6mm doubler). Leave the middle piece of C5 in place with the removable tape and then glue the rear piece in position. Again, use low tack tape for clamping the assembly.
- Once the pieces have been clamped in place you can remove the middle piece, strengthen it up and create an attachment mechanism. In the prototype we reinforced the radio hatch with 3mm X 0.5mm Carbon Strips, one on each side just inside of the fuselage doublers and we glued 3mm Depron tabs front and rear. To remove the hatch just use the cooling vents to fold the middle up and release one of the tabs.

## 10.4 Close Fuselage Front, Top and Bottom

We will close the top and the bottom of the front of the fuselage together. This will ensure that the front of the fuselage sides fold in and align correctly.

### Parts Required

	Fuselage Assembly
A4	Fuselage Front Bottom
C3	Fuselage Front Top and Battery Hatch
	Ultimate RC Foam Glue

### Procedure

- If you have not cut C3 in two sections to make the fuselage front top and the battery hatch do so now.
- Fold the fuselage sides inwards a little to get them used to the position they will be glued into.
- Start at the front and work towards the rear gluing first the top front and then the bottom front using Ultimate RC Foam Glue and use low tack tape to clamp it together. Run a couple of pieces of tape across the front of the nose to hold the sides bent into position while the glue dries.
- When the glue is dry trim the rear of the bottom front to suit the contour of the fuselage.

- If necessary trim the battery hatch so that it fits the opening. Like the bottom hatch, reinforce it and use your attachment mechanism of choice. The prototype hatch was again reinforced with 2 3mm X 0.5mm Carbon Strips, used a 3mm Depron tongue in the front and a custom made hatch latch in the rear.

## 10.5 Tail Wheel and Rudder Installation

If you will be using a steerable tail wheel design you assembly so that you can adequately tie it in to the rudder. In this step we will mount the tail wheel and the rudder. Since the rear of the fuselage is very narrow and made up entirely out of foam we use a tail wheel mounting bracket to reinforce this section. The following instructions assume that you will be using a steerable landing gear similar to the one used in the prototype.

### Parts Required

	Fuselage Assembly
A2	Rudder Assembly
E4	Tail Wheel Bracket
	Steerable Tail Wheel Assembly
	Scrap Carbon or Plywood Reinforcement plates
	Epoxy or Foam Safe CA glue

### Procedure

- Put together the tail wheel assembly and make any necessary bends to the wire to match your geometry. Before locking the tail wheel wire in place it may be a good idea to fill the hole with some petroleum jelly to prevent against any accidental glue seeping into it. Clean the wire thoroughly with rubbing alcohol before bending and subsequent bonding to remove any petroleum jelly from it. Temporarily attach it in place to the tail wheel bracket E4 and use low tack tape to attach the assembly to the fuselage assembly. Using low tack tape as a temporary hinge, attach the rudder assembly A2 to the fuselage assembly. Make sure that the pivot axis for the tail wheel is in-line with the hinge line for the rudder.
- Once the tail wheel geometry is correct make a cutout in the rudder to fit the tail wheel steering guide wire. This cutout will be reinforced with light ply or carbon fiber plate once everything is assembled.
- Once everything has been dry-fitted remove the rudder and start gluing the tail wheel assembly and the tail wheel bracket in position on the fuselage. You can use Epoxy or Foam Safe CA for this step. Be careful not to get any glue in the tail wheel assembly hole because we don't want to create any unnecessary load on the rudder servo.

- Once tail wheel assembly is fixed in position permanently attach the rudder using your favorite hinging mechanism. When doing this check to make sure that the tail wheel steering guide wire is in the position in which it will end up.
- Glue the tail wheel steering guide wire in position again making sure that you don't get any glue in the tail wheel assembly hole.
- Apply the plywood or carbon reinforcement plates to either side of the rudder where the steering guide wire sits to strengthen the rudder.
- Finally, install the tail wheel.

**This completes the second stage of the Fuselage Assembly**

# 11 Wing Assembly

We will now use the Wing Skins and Wing Spar that were assembled in Chapter 4 and the Ailerons that were assembled in Chapter 7 and mount them to the fuselage assembly.

## 11.1 Attach Wing Spar to Fuselage Assembly

First step in the wing assembly is to attach the wing spar to the fuselage.

### **Parts Required**

- Fuselage Assembly
- B1 Wing Spar Assembly
- Scrap material for shims, this can be anything you find handy
- 5 Minute Epoxy

### **Procedure**

- Before continuing with the assembly, make sure that you have transferred the reference marks for the two intermediate wing ribs onto the spar; this will make aligning the ribs easier later. If you did not get the positions off the paper template before removing it they are 6.1" from the tip of the spar and 11.8" from the tip of the spar.
- Next to getting the fuselage straight, this is the most critical step in the whole build of the airplane so take your time, if you don't you will end up with a crooked airplane and crooked airplanes don't fly straight. Dry fit the spar in its slot in the fuselage and note how tight or how loose the fit is. If the fit is too tight don't force it, sand or file away some foam until you get a "slip fit". If the fit is too loose we will shim the spar in order to achieve the desired fit.
- We now need to make sure that the spar is even on both sides (by measuring from spar tip to fuselage on both sides) of the fuselage, square to the fuselage (by measuring spar tip to tail on both sides) and parallel to the ground plane and elevator (by setting the plane down on a reference surface and measuring spar tip to it on both sides).
- Again, take your time in this step; if any of the measurements are off adjust the spar by sanding and or shimming as necessary. When done mark the spar carefully so that you can glue it in exactly the same position.
- Glue the spar in position using 5 Minute Epoxy double checking all your measurements when the spar is in position. Clean any excess glue off the spar with rubbing alcohol before it dries. Make sure the glue is thoroughly dry before proceeding to the next step.

## 11.2 Attach Wing Ribs to Spar

The ribs help the wing better hold its shape, attaching them is a simple process.

### Parts Required

Fuselage Assembly  
 Wing Ribs, (Parts B10 – B18, 2 of each)  
 Foam Safe CA

### Procedure

- Before gluing the ribs to the spar make sure that they aren't taller at their attachment point than the spar itself; the wing skins need to make good contact with the spar when bonded and we don't want the ribs to get in the way. If any of the ribs are too tall sand them down before attaching them.
- The longest ribs are glued to the spar, the alignment pins and to the fuselage. The rest of the ribs are glued to the spar at their corresponding locations (the shortest ribs go flush with the tip of the spar). Glue the ribs with foam safe CA making sure that they are square to the spar

## 11.3 Attach the Wing Skins

Next step is to attach the wing skins. We will describe the steps for attaching the first skin the second one uses the same procedure.

### Parts Required

Fuselage Assembly  
 D1 Right Wing Skin (2)  
 D2 Left Wing Skin (2)  
 Foam Safe CA  
 30 Minute Epoxy

### Procedure

- First step is to sand a slight taper to the inside trailing edges of both the wing skins (top and bottom). We want to thin the 2mm Depron enough so that it's about 1.5mm thick and we want to increase the bonding area to about 5mm. Use some sand paper attached to a flat block to accomplish this and clean the area thoroughly with rubbing alcohol when complete.
- Before mixing the Epoxy make sure you do a dry fit and that the skins fold and align correctly. If you have a hard time folding the skins around the leading edge you may want to create a couple of scores with a blunt object. Another thing you will want to do here is to test your clamping strategy, some flat clamping cauls along the trailing edge will be helpful. In addition you will want to find a way to press the skin to the spar, one option will be to "hang" the airplane off the edge of a table from the wing placing

heavy items such as books on top of the spar, this will create pressure on the spar on both the top and the bottom of the wing.

- When you are satisfied everything is going to fit correctly start by tacking the leading edge of the wing to the front of the ribs and the front alignment pin using foam safe CA. Make sure that the wing skin is aligned properly
- Mix up some 30 minute epoxy (you can lighten it slightly with Microballoons if you wish) and spread it sparingly on the spar, the trailing edge of the wing skin and the ribs. Make sure you don't starve the joint, it is important to get enough on the spar and the trailing edge. Clamp everything together using the clamping strategy you devised.
- When the glue is dry repeat on the other wing.

## 11.4 Create Wing Fillet

We will now reinforce the joint where the Wing Skins meet the fuselage.

### **Parts Required**

Airplane Assembly  
30 Minute Epoxy  
Microballoons

### **Procedure**

- Tape off the wing and the fuselage with low tack tape creating a channel 3mm – 5mm wide where the wing skins meet the fuselage.
- Mix 30 Minute Epoxy and Microballoons into a mixture containing about a 1:4 ratio. We want to make this as lightweight as possible and with the consistency of cake icing. Make note of when you activate the glue as you will need to keep track of this.
- Apply the glue to the wing joint and shape it to a radius using a small tube or other available tool, a small piece of scrap carbon tube or a wooden coffee stirrer make good fillets.
- You want to remove the tape from the airplane when the glue begins to set up but before it becomes completely solid. This will be about 20 – 25 minutes after you start mixing it.

## 11.5 Make Wing Tips

Here you get to explore your artistic side, time to make wing tips.

### **Parts Required**

Airplane Assembly  
Scrap 3mm Depron  
Ultimate RC Foam Glue

**Procedure**

- Cap off both wing tips using a couple of scrap 3mm Depron foam pieces and Ultimate RC Foam Glue.
- Once the glue is dry carve and sand the pieces to a shape that works for you. We curved radiused the edges, radiused the leading edge slightly and tapered the trailing edge.

## 11.6 Install Ailerons

All that is left to complete the wings is to install the ailerons.

**Parts Required**

Airplane Assembly  
Aileron Assemblies (A1)

**Procedure**

- Test fit the ailerons using low tack tape. Make sure that downward movement is not impeded by the fuselage as the taper of the aileron may interfere with the widening at the bottom of the fuselage.
- Once you are satisfied with the position of the ailerons attach them to the wings with your favorite hinging method.

**This completes the Wing Assembly**

## 12 Landing Gear and Wheel Pants

### 12.1 Attach Wheel Pant Brackets to Wheel Pants

Before gluing together the wheel pants we will install the wheel pant hardware. It will be much easier to do this now than after the assembly of the wheel pant is complete

#### Parts Required

- A8 Wheel Pant Right Side (2)
- A9 Wheel Pant Left Side (2)
- E12 Wheel Pant Brackets (4)
- Wheel Collets (4)
- Scrap piece of landing gear axle
- Foam Safe CA
- CA Glue

#### Procedure

- First step will be to glue the wheel collets to the Wheel Pant Brackets (E12). The set screw (grub screw) needs to face down and align with the gap in the bottom of the Wheel Pant Bracket. Place the assembly on some wax paper on a flat surface and attach the pieces to each other using CA glue (be very careful not to get any glue on the set screw!!!). The following diagram shows how the Wheel Collet needs to be positioned in the Wheel Pant Bracket (note the set screw position).

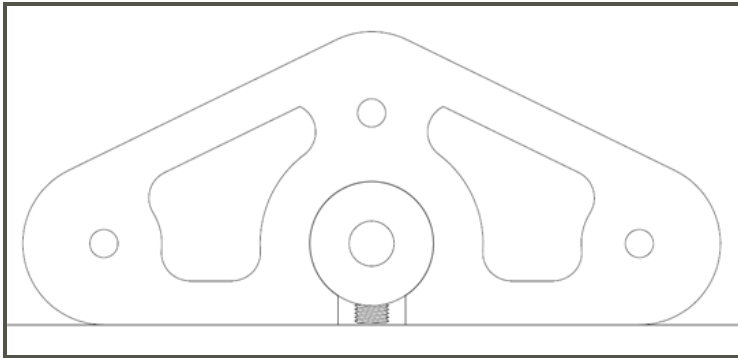

Figure 21 - Wheel Pant Bracket Detail

- Once all the wheel collets have been attached to the Wheel Pant Brackets they need to be attached to the side pieces of the wheel pants (A8 & A9). Make sure that they correctly line up with the holes in the Wheel Pant Sides by using a scrap piece of wheel axle through the collet and the Wheel Pant Side. Also make sure that the bottoms of the Wheel Pant Bracket and the Bottoms of the Wheel Pant Sides line up. Finally, make sure that you make 2 left sides and 2 right sides. Glue the Wheel Pant Brackets to the Wheel Pant Sides using Foam Safe CA. Again, make sure you get no glue on the set

screw or in the holes where the wheel pants will go. The following diagram shows the correct position of the Wheel Pant Brackets on the Wheel Pant Sides:

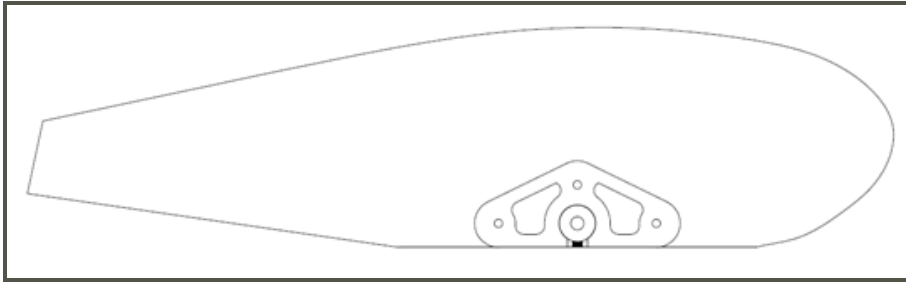

Figure 22 - Wheel Pant Bracket Position

## 12.2 Glue Together Wheel Pants

Once the Wheel Pant Brackets have been installed we can glue the wheel pants together.

### Parts Required

- Wheel Pant Side Assemblies (A8 & A9)
- A7 Wheel Pant Centers (2)
- B18 Wheel Pant Spacers (4)
- Ultimate RC Foam Glue

### Procedure

- This is a simple matter of gluing together the 5 part sandwich for each wheel pant. The sandwich order is as follows: A8 – B18 – A7 – B18 – A9. See the following diagram for assembly order:

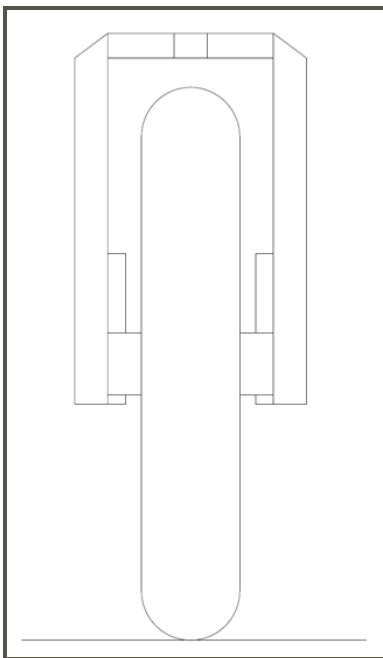

Figure 23 - Cross Sectional View of Wheel Pant Assembly

- Use thin layers of Ultimate RC Foam Glue on the surfaces to create the sandwich. Once dry the glue will be rubbery and can be easily shaped as you give the wheel pants their final shape.
- Remember that in the assembly the Wheel Pant Brackets and Wheel Collets will face the **inside** of the wheel pant.
- Place some axle stock through both wheel collets and tighten the set screws. This will ensure that the assembly ends up straight and that you will be able to feed the axle through it later.
- Once the glue has dried on the wheel pants round the edges and give them an appealing shape. Be careful not to carve too much in the center top as this is where the assembly is at its thinnest.

## 12.3 Install Axles on Landing Gear

Before gluing the landing gear onto the fuselage we will install the axles. The following diagram can be used as reference for the installation of the axles:

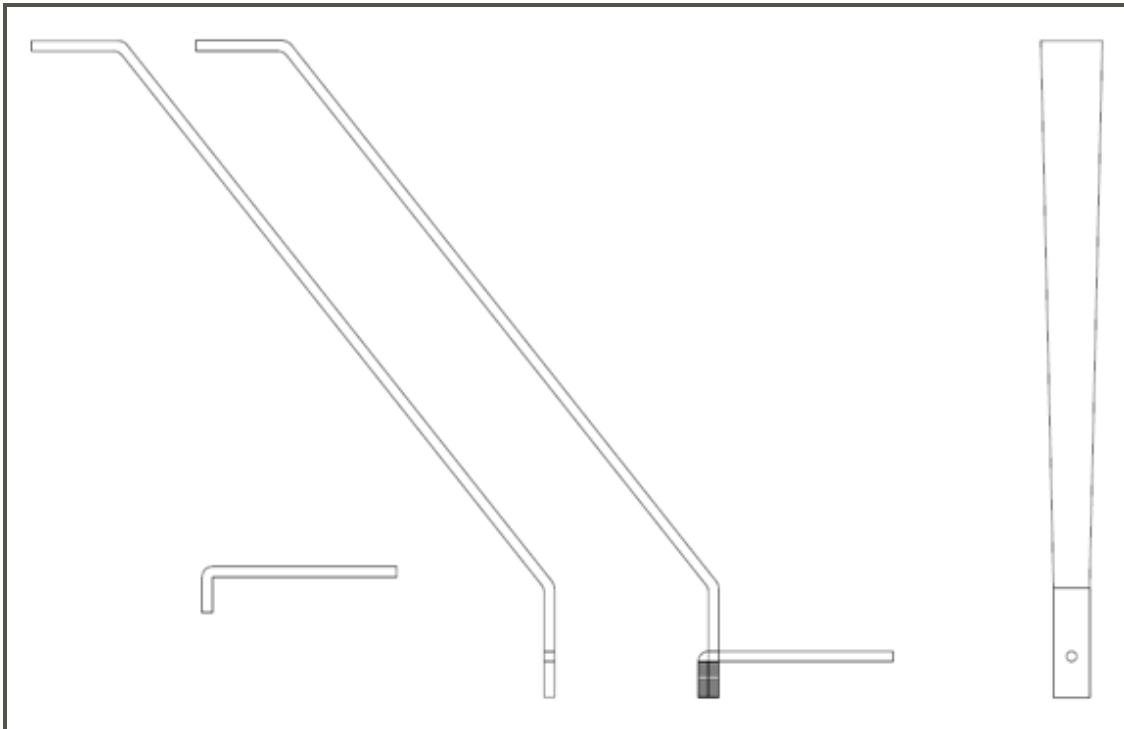

Figure 24 - Axle Installation Reference

### Parts Required

Carbon Fiber Landing Gear  
 1/16" Music Wire (diameter to fit your wheels)  
 Kevlar Thread  
 CA Glue

### Procedure

- Start by drilling a hole in Carbon Fiber landing gear about ¼" above the bottom.
- Bend a right angle into your axle stock 1.4" from the end. The remaining axle needs to be at least 7/8" long but it may be better to leave it longer and trim it to final length when the wheel pants have been installed.
- Test fit the axle as shown in the diagram and make sure that it fits the hole correctly, flush and at the right angle. Make any adjustments necessary to the axle and the landing gear. Once the axle fits correctly adhere it with CA glue.
- Once the axle is in glued in place we are going to reinforce it with a Kevlar thread wrap. Once the Kevlar wrap is complete soak it with thin CA glue to make stiffen it up.

## 12.4 Attach Landing Gear to Airframe

It's time to install the landing gear on the fuselage.

### **Parts Required**

- Airplane Assembly
- Landing Gear Assemblies
- E10 Landing Gear Fuselage Doublers (2) (Optional CF component)
- 5 Minute Epoxy

### **Procedure**

- Dry fit the Landing Gear Assembly in the slots of the fuselage, if the fit is a little tight sand the Carbon Fiber Landing Gear to get a smooth fit.
- Scuff up and clean the Carbon Fiber Landing Gear where they will be adhered to the airframe.
- Mix 5 Minute Epoxy for one side at a time. Slip the Landing Gear Doubler over the end of the landing gear and push it as far as it will go. Place glue on the Landing Gear and the inside of the Landing Gear Doubler and insert it into the slot until it is completely seated. Clean off any excess glue with rubbing alcohol. You may want to tape down the Landing Gear Doubler with low tack tape to make sure you have good adhesion. Wait for the glue to dry thoroughly.
- Repeat for the Landing Gear on the other side.

## 12.5 Add Landing Gear Cross Bracing

In order to reinforce the Carbon Fiber Landing gear we will add some Kevlar thread bracing. This cross bracing adds an incredible amount of strength to the gear while adding a very minimal amount of weight. The bracing will be added to the landing gear in the pattern shown in the following diagram:

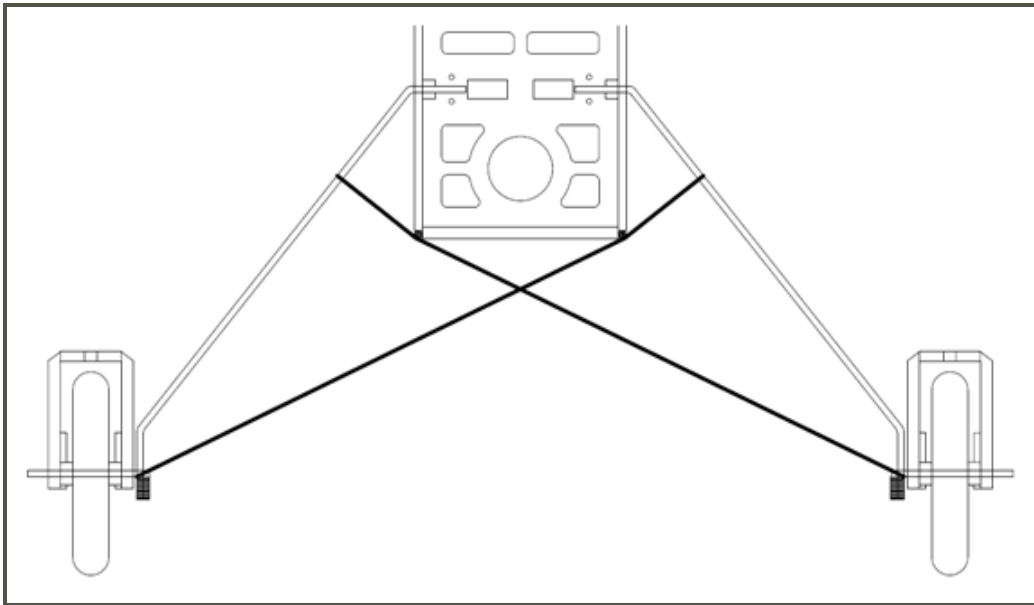

Figure 25 - Landing Gear Cross Bracing Geometry

### Parts Required

- Airplane Assembly
- 2mm Carbon Fiber Rod (or similar, you can substitute piano wire)
- Kevlar Thread
- Foam Safe CA

### Procedure

- First we will install wear or rub doublers, these will prevent the foam from being damaged by the Kevlar cross bracing. Cut a small square groove 1" long out of the bottom fuselage corners centered on the Carbon Fiber landing gear struts. Cut some 2mm (or similar) Carbon Fiber rod to the same length as the slots. Glue the carbon fiber in place with some foam safe CA glue. You may optionally like to cover it with a small strip of hinge tape or packing tape to smooth out the surface.

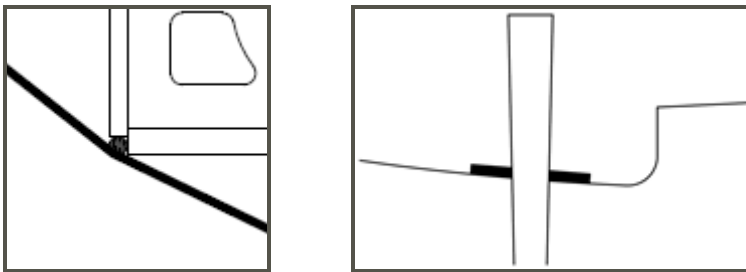

Figure 26 - Landing Gear Cross Bracing Wear Doublers

- Once the wear doublers are in place loosely wind Kevlar thread around the landing gear struts. You want to wind about 6 turns of Kevlar Thread in a figure 8 pattern starting at the bottom of the strut below the axle and going to the top of the opposite strut. Make sure that you only wind with enough tension to keep the thread from going slack, we don't want to bow the

landing gear inwards. Start and end your wind at the axle with some simple knots and reinforce these knots with a drop of foam safe CA glue when done. Repeat the wind in the opposite orientation.

- Once both the winds are complete wrap a few turns of thread around the spot where the two winds cross and again secure it with a knot and some foam safe CA glue.
- Finally, you may want to add a drop of glue where the top of the wind crosses the top of the landing gear.

## 12.6 Mount Wheel Pants and Wheels

Assemble the Wheel Pants to the Axles. Due to the limited amount of space available it may be helpful to hold the washers with tweezers.

### **Parts Required**

Airplane Assembly  
Wheel Pant Assembly (2)  
Steel or Nylon Washers (4)  
2" Wheels (2)

### **Procedure**

- Assemble the Wheel Pants onto the axles slipping in the wheel and two washers (one on either side of the wheel) with the Wheel Pant onto the axle. Push the assembly as tight to the Landing Gear as Possible. Set the plane on a flat surface and line up the wheel pants to your satisfaction, tighten the set screws (you may want to apply thread locking compound). There is no need attach the Wheel Pant to the Landing Gear itself, the wheel collets hold it in position more than adequately.
- Trim the excess axle flush or slightly proud (your preference).
- If you leave the axle proud you can cap it with some scrap foam or you can cap it with a commercial axle cap (again, your preference).

**This completes the Landing Gear and Wheel Pant Installation**

## 13 Final Assembly

### 13.1 Apply Decals

There are two sets of trim schemes provided for the MXS, Green Flames:

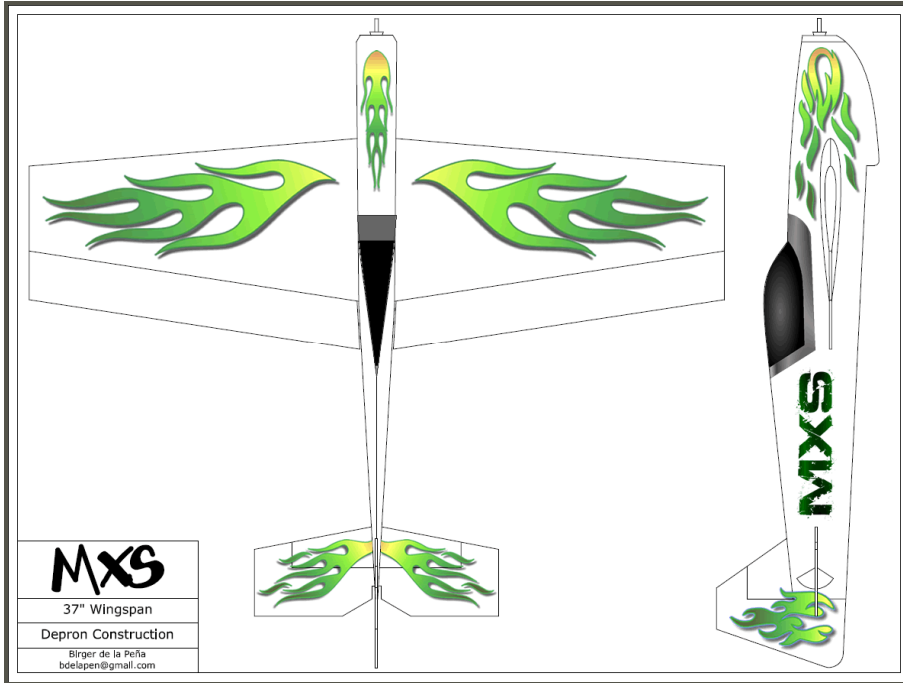

Figure 27 - Green Flames Trim Scheme

Blue Tribal:

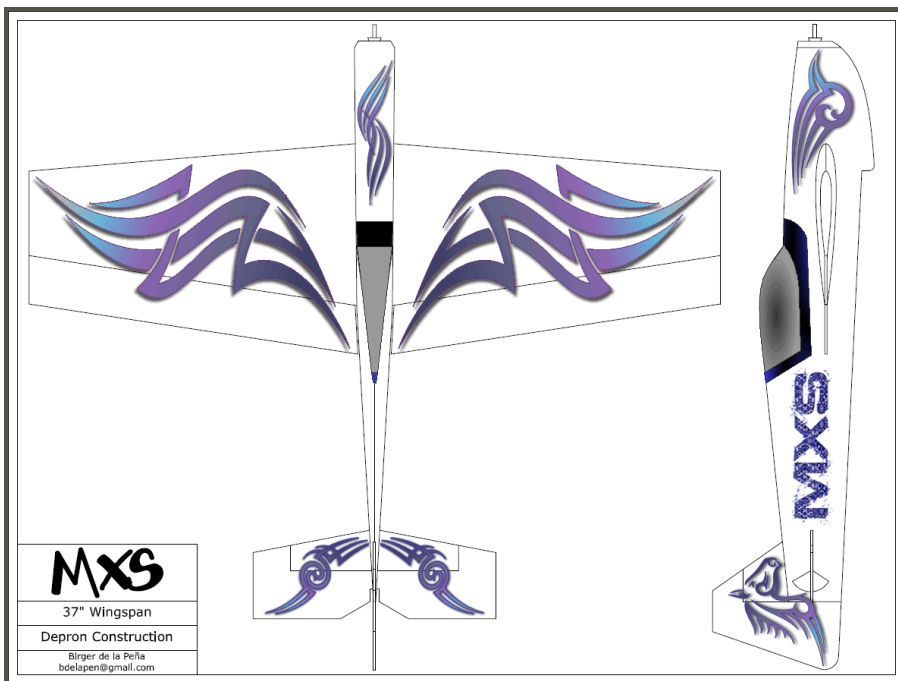

Figure 28 - Blue Tribal Trim Scheme

Print the supplied patterns on self adhesive, clear gloss printer paper for best results. If you print on an Inkjet printer you will probably want to spray the decals with some kind of clear lacquer to avoid color runs due to water or humidity. If you print on a color laser printer this is not necessary as the toner is baked on and will not run with water.

Trim the decals as close as possible to the edges to save as much weight as possible. Try to avoid any sharp corners as these will start to peel easier than rounded corners. For larger decals, align and join them to each other using low tack tape before removing the backing. This will allow you to handle them as a single unit when applying them.

Once all the decals have been applied you may want to run over them with a hobby covering iron at a low temperature setting. This will activate the glue and provide a better bond. If you used tape for hinging your control surfaces this would be a good time to run over the tape to achieve the same result.

## 13.2 Make and Install Control Rods

The only thing left to do to complete the airplane is to make and install control rods. You can follow whatever procedure you want to make your control rods but we make our control rods out of carbon fiber tubes with music wire ends. The music wire is glued to the carbon fiber and then reinforced with Kevlar thread soaked in CA glue.

If you choose to use this method for making your control rods start by measuring the distance between the servo arm and the control horn. Cut your carbon fiber rod 1" shorter than this distance (we use 2.1mm hollow carbon rod). Cut two 1 1/4" long pieces of music wire to suit your hardware (we use 0.32" diameter music wire).

Make a 90° bend on one of the pieces of music wire about 3/16" in from the end. Overlap the wires about 3/8" and glue them to the carbon rods using CA glue. Finally wrap the wires and rods with Kevlar thread to reinforce them and soak the wrap with thin CA glue.

Install the control rods on the airplane.

**This completes the construction of the MXS**

## 14 Flight Setup

### 14.1 Center of Gravity

You will want to set up your MXS with the center of gravity at the spar for the maiden; this is 2 7/8" – 3" behind the leading edge. Your style of flying will determine your final CG location but for stunt or 3D you will eventually want to move it backward 1/2" to 3/4", experimentation is key!

### 14.2 Control Surface Movements

The MXS is designed to be able to take as much as 60° of control throw in both directions on all surfaces. For the maiden we recommend the following:

High Rates:

Rudder: 55° Throw, 25% – 35% Expo

Elevator: 45° Throw, 40% – 65% Expo

Ailerons: 45° Throw, 40% – 65% Expo

Low Rates:

Rudder: 75% – 80% Throw, 15% – 25% Expo

Elevator: 50% – 60% Throw, 25% – 40% Expo

Ailerons: 50% – 60% Throw, 25% – 40% Expo

From here you can change the control throws to suit your flying style.

### 14.3 Range Check

Remember to always range check you radio in any new installation, we wouldn't want all this work to go to waste on such an avoidable and mundane issue would we? While you are at it, if you have a 2.4 GHz system it may be a good idea to make sure you have a good bind, check with the manufacturer of your system for the correct procedure

### 14.4 Final Inspection

Make sure you make one final inspection before flight. This is not meant to be an exhaustive list but the here are some of the key aspects we look at:

- General airframe soundness; are there any cracks breaks or weak points? If so repair or reinforce them before flight.
- Drive train; make sure that the motor mount, motor and propeller are mounted properly and firmly. Make sure that the propeller is mounted in the right direction (traction in the case of the MXS) and rotating in the right direction.
- Electronics make sure that all wires are correctly plugged in and completely seated. Make sure that there are no loose wires and if there are tie them down.

- Control surfaces; are they all moving in the right direction? Are they moving the right amount? Are high rates and low rates correct? Is your exponential working in the right direction?

**This completes the flight setup for your MXS.**

**We sincerely hope you enjoy your MXS as  
much as we have enjoyed bringing it to  
you!!!**