

Sez. B - B

Sez. B - B

B.E. DEPRON 6 mm

DEPRON 6 mm

POSSIBILE ESTENSIONE SUPERFICIE MOBILE (ENTRambi I LATI)

Cappottina costruita con strati sovrapposti di depron da 6 mm spostata

profilo tipico ala

6 pezzi Balsa 2 mm

2 pezzi Balsa 2.5 mm

Sez. A - A

ACCIAIO 2 mm DI DIAMETRO

TERMINALE COSTRUITO CON SANDWICH DI 4 STRATI DI DEPRON DA 6 mm SOVRAPPosti E SVUOTATI ALL'INTERNO FINO AD UNO SPESSORE DI CIRCA 5-6 mm

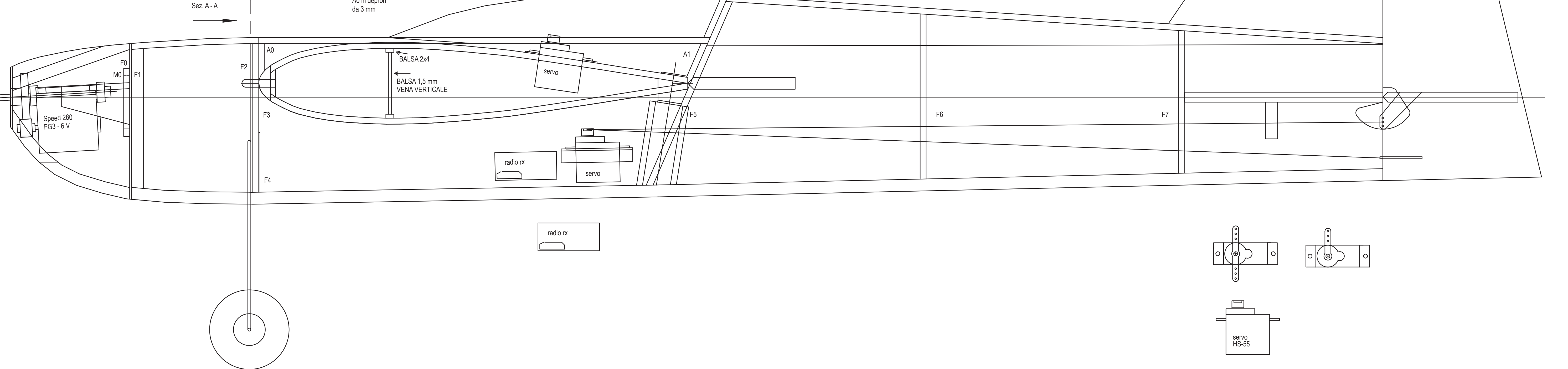
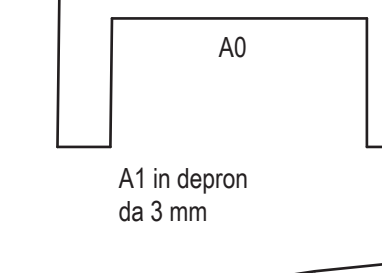
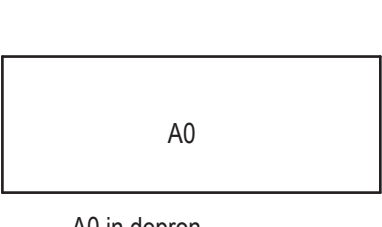
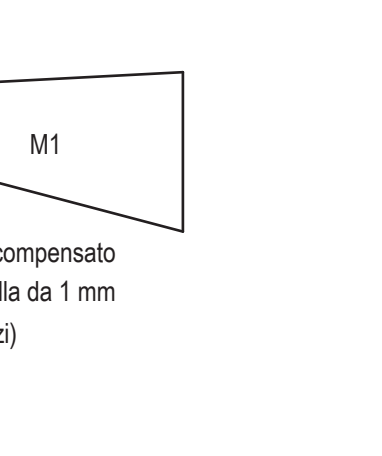
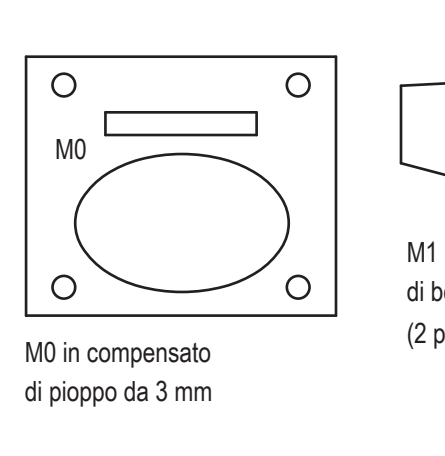
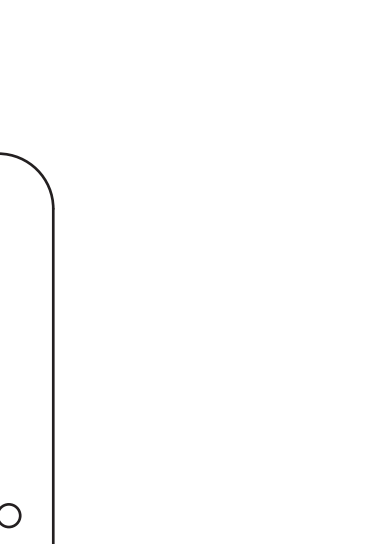
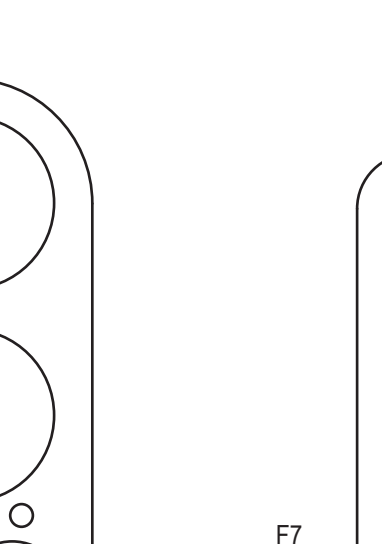
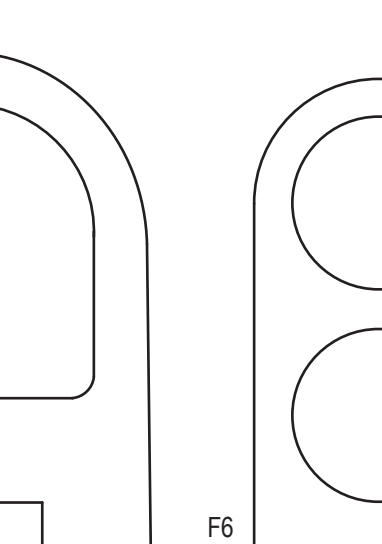
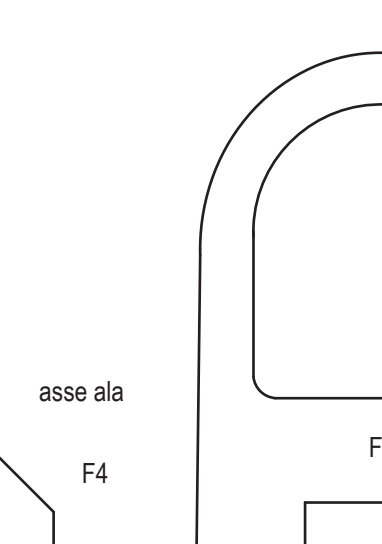
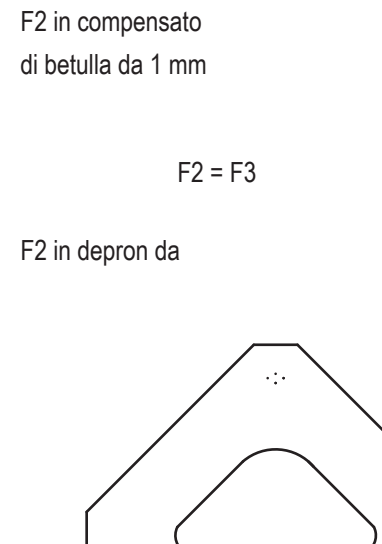
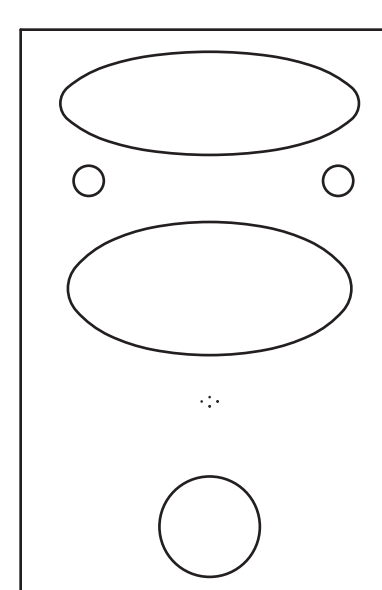
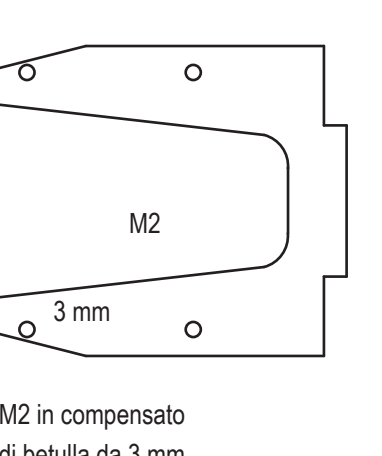
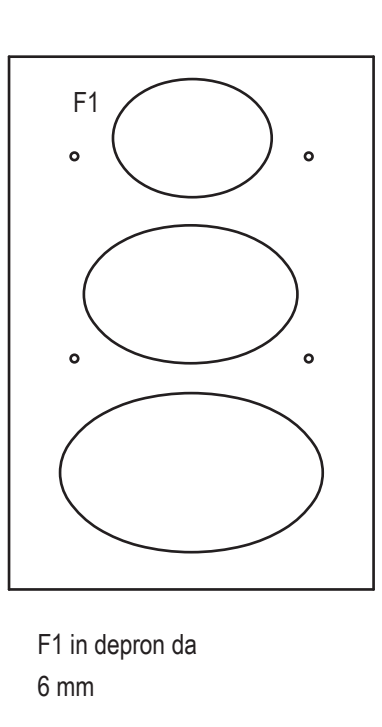
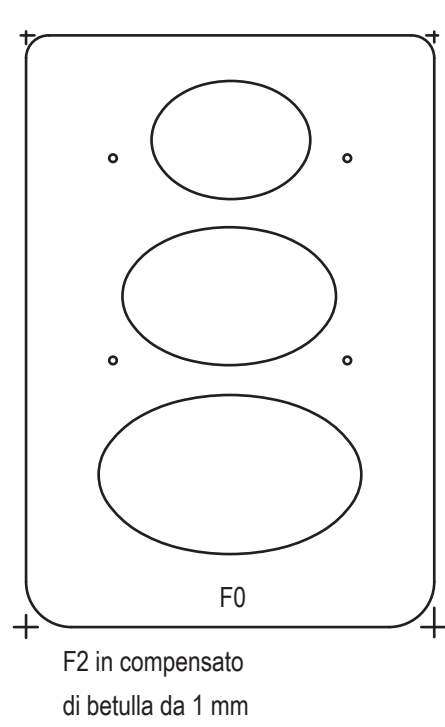

Sez. A - A

