



The **Fokker DR.I Dreidecker** (triplane) was a World War I fighter aircraft built by Fokker-Flugzeugwerke. The DR.I saw widespread service in the spring of 1918. It became renowned as the aircraft in which Manfred von Richthofen gained his last 19 victories, and in which he was killed on 21 April 1918. The first two pre-production triplanes were designated F.I, in accord with Idflieg's early class prefix for triplanes. These aircraft, serials 102/17 and 103/17, were the only machines to receive the F.I designation and could be distinguished from subsequent aircraft by a slight curve to the tailplane leading edge. They were sent to Jastas 10 and 11 for combat evaluation, arriving at Markebeeke, Belgium on 28 August 1917. Richthofen first flew 102/17 on 1 September 1917 and shot down two enemy aircraft in the next two days. He reported to the Kogenluft (Kommandierender General der Luftstreitkräfte) that the F.I was superior to the Sopwith Triplane. Richthofen recommended that fighter squadrons be re-equipped with the new aircraft as soon as possible. The combat evaluation came to an abrupt conclusion when Oberleutnant Kurt Wolff, Staffelführer of Jasta 11, was shot down in 102/17 on 15 September, and Lieutenant Werner Voss, Staffelführer of Jasta 10, was killed in 103/17 on 23 September. The remaining pre-production aircraft, designated DR.I, were delivered to Jasta 11. Idflieg issued a production order for 100 triplanes in September, followed by an order for 200 in November. Apart from minor modifications, these aircraft were almost identical to the F.I. The primary distinguishing feature was the addition of wing-tip skids, which proved necessary because the aircraft was tricky to land and prone to ground looping. In October, Fokker began delivering the DR.I to squadrons within Richthofen's Jagdgeschwader I. Compared to the Albatros and Pfalz fighters, the DR.I offered exceptional manoeuvrability. Though the ailerons were not very effective, the rudder and elevator controls were light and powerful. Rapid turns, especially to the right, were facilitated by the triplane's marked directional instability. Vizfeldwebel Franz Hemer of Jasta 6 said, "The triplane was my favourite fighting machine because it had such wonderful flying qualities. I could let myself stunt — looping and rolling — and could avoid an enemy by diving with perfect safety. The triplane had to be given up because although it was very manoeuvrable, it was no longer fast enough." As Hemer noted, the DR.I was considerably slower than contemporary Allied fighters in level flight and in a dive. While initial rate of climb was excellent, performance fell off dramatically at higher altitudes because of the low compression of the Oberursel Ur.II, a clone of the Le Rhône 9J rotary engine. As the war continued, chronic shortages of castor oil made rotary operation increasingly difficult. The poor quality of German ersatz lubricant resulted in many engine failures, particularly during the summer of 1918.

The DR.I suffered other deficiencies. The pilot's view was poor during take-off and landing. The cockpit was cramped and furnished with materials of inferior quality. Furthermore, the proximity of the gun butts to the cockpit, combined with inadequate crash padding, left the pilot vulnerable to serious head injury in the event of a crash landing.





**NOTES:**

- \* All parts are made from 6mm Depron or BlueCore foam unless otherwise indicated
- \* Recommended control deflections for sport flying (all dimensions measured at trailing edge):
  - Ailerons: +/- 0.75" (-40% expo)
  - Elevator: +/- 1.5" (-60% expo)
  - Rudder: +/- 2.0" (-50% expo)
  - Flaps: 0.25" down (for adding camber)
- \* For 3D aerobatics, set all control throws to maximum (+/- 60 degrees)
- \* Flaps can be used to add camber for improved slow flying characteristics. Use .25" down flap travel, and mix in 15% up elevator to maintain trim.
- \* The CG location shown will provide moderate pitch stability. The CG can be moved aft up to 0.25" for more neutral pitch stability.
- \* Use a heat gun to gently form the foam in the fuselage to the shapes shown

**RECOMMENDED POWER SYSTEM:**

- \* For best results choose a power system that provides 25-30 oz static thrust and 30-35 mph pitch speed.
- \* Recommended setup is Himax 2015-4100 with 6.6:1 gearing, 12x6 APC Slowflyer prop, 1320 mAh 11.1V lithium-polymer battery, and Castle Creations Phoenix 25 speed control

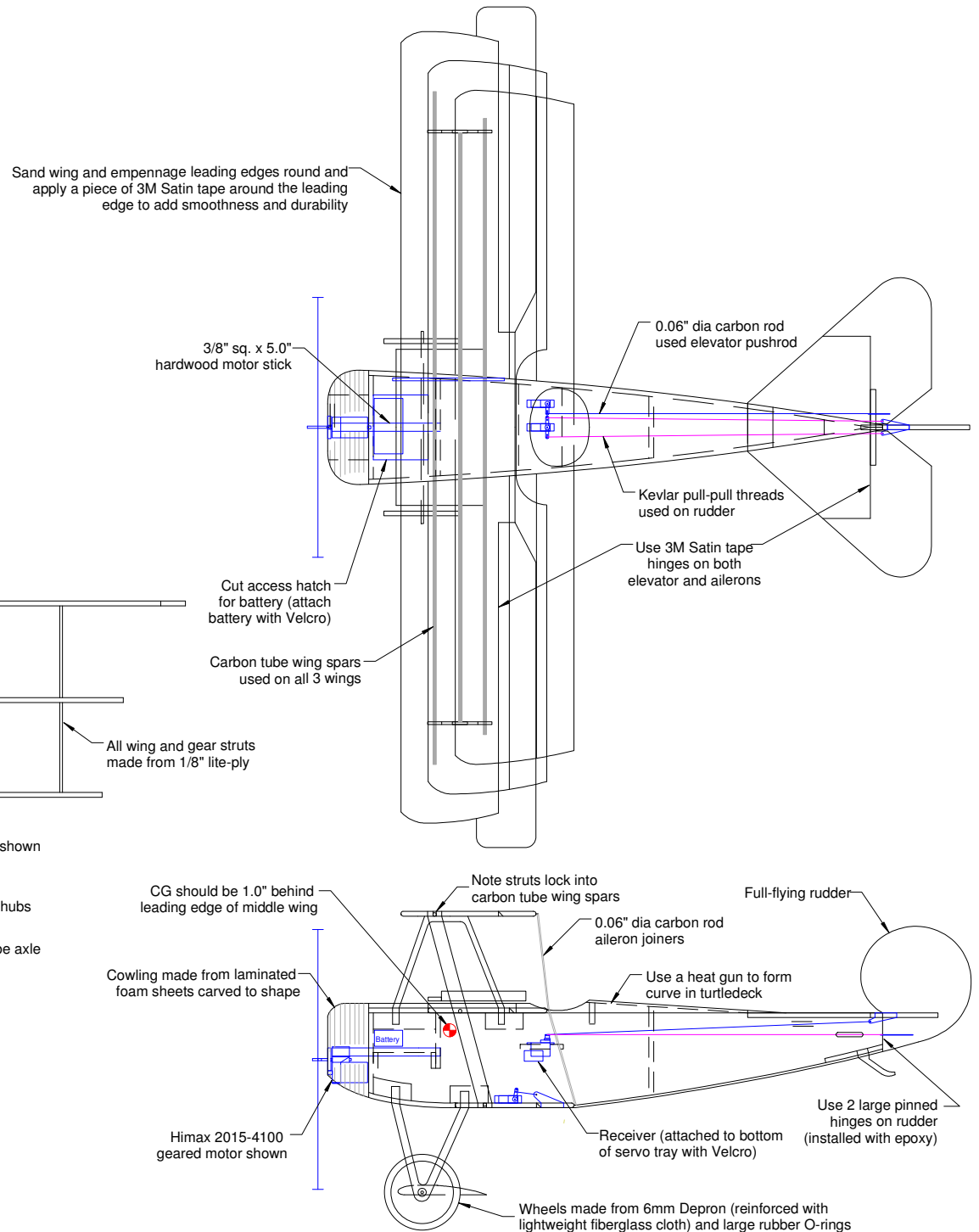
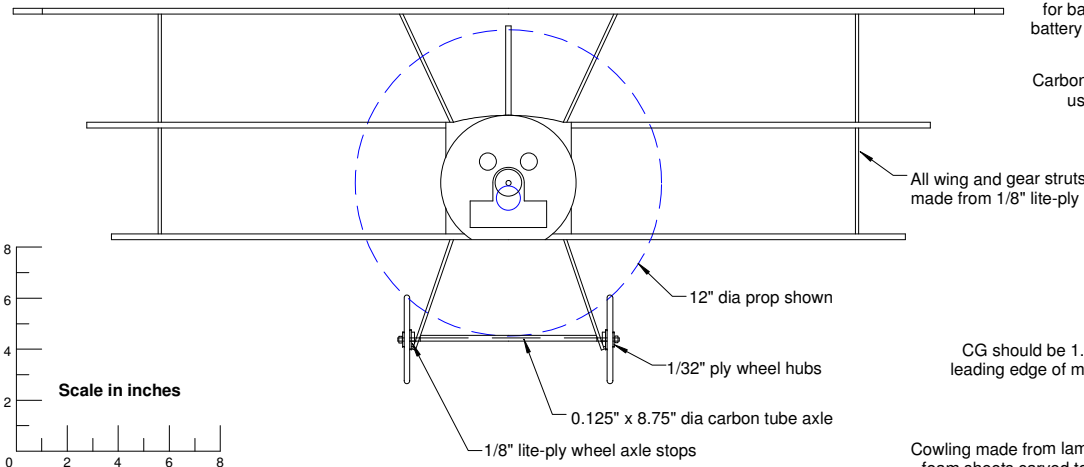

## Fokker DR1 Parkflyer

Span: 36.5"  
 Wing area: 575 sq in  
 Weight: 19 - 22 oz RTF  
 Wing loading: 5.2 oz/sq ft

Designed and drawn by Steve Shumate  
 Copyright © 2005 All Rights Reserved

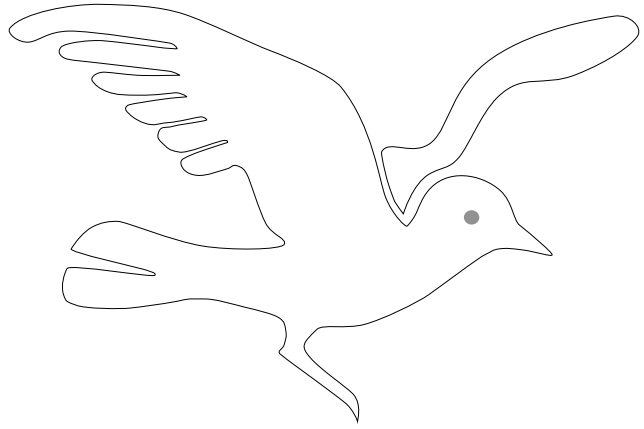
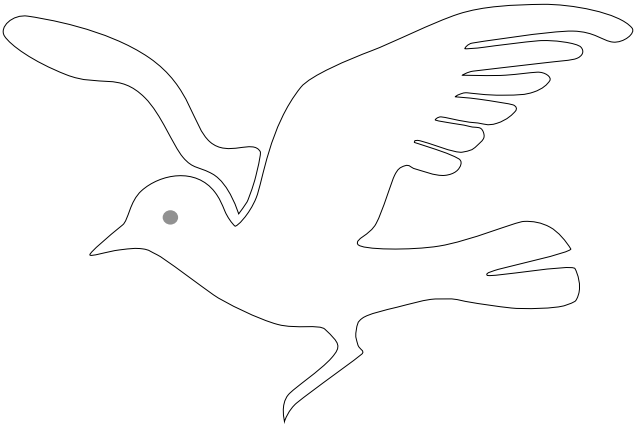

*Fokker*

DR. I

*Fokker*

DR. I

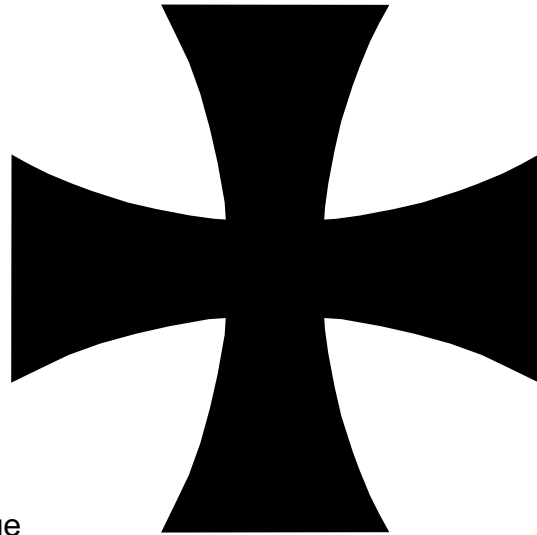
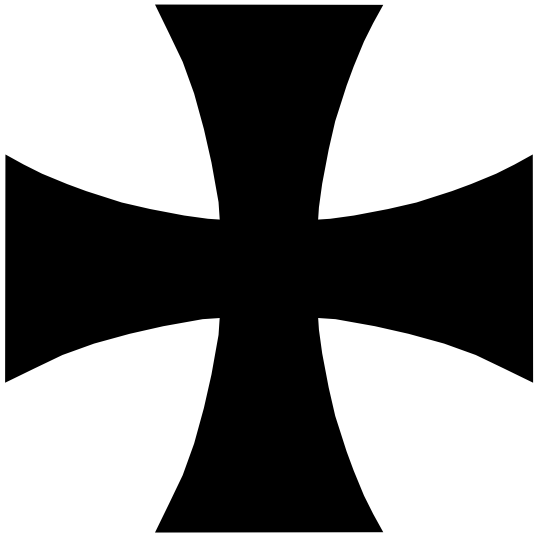

Fuselage  
and Rudder

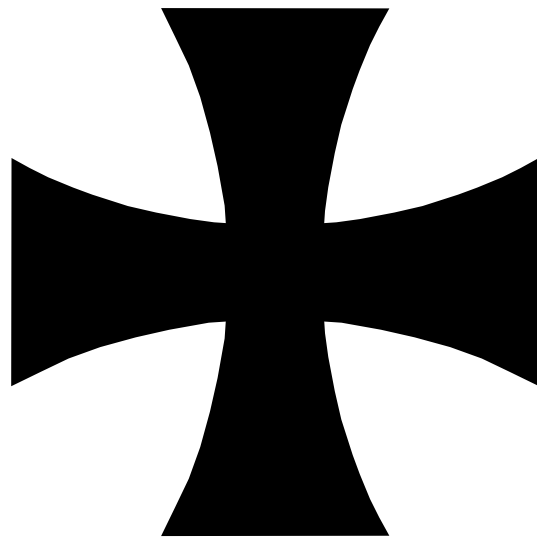
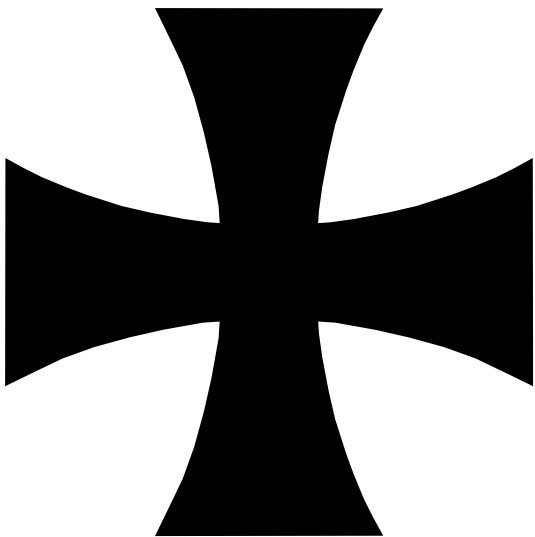

Top Wing

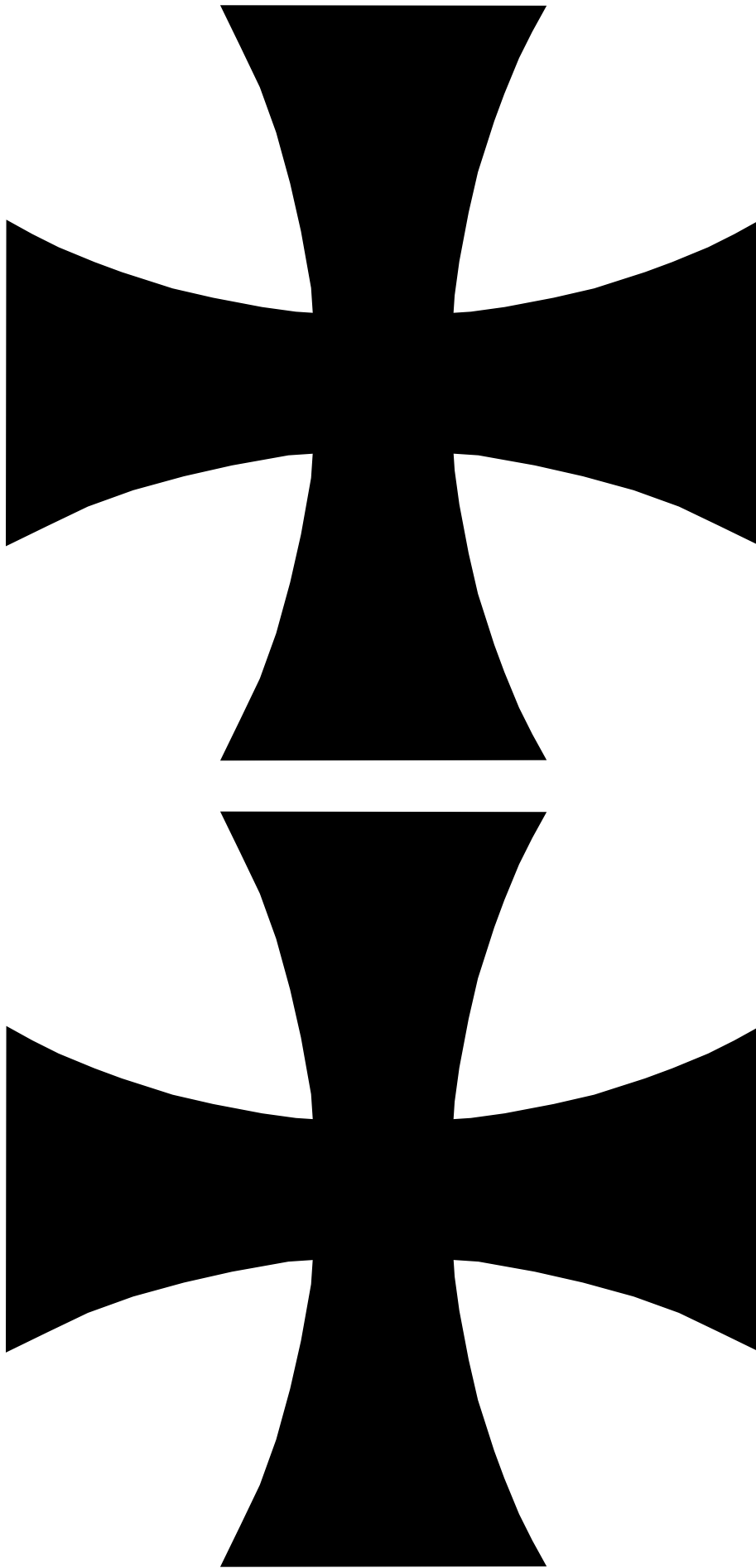

Bottom Wing

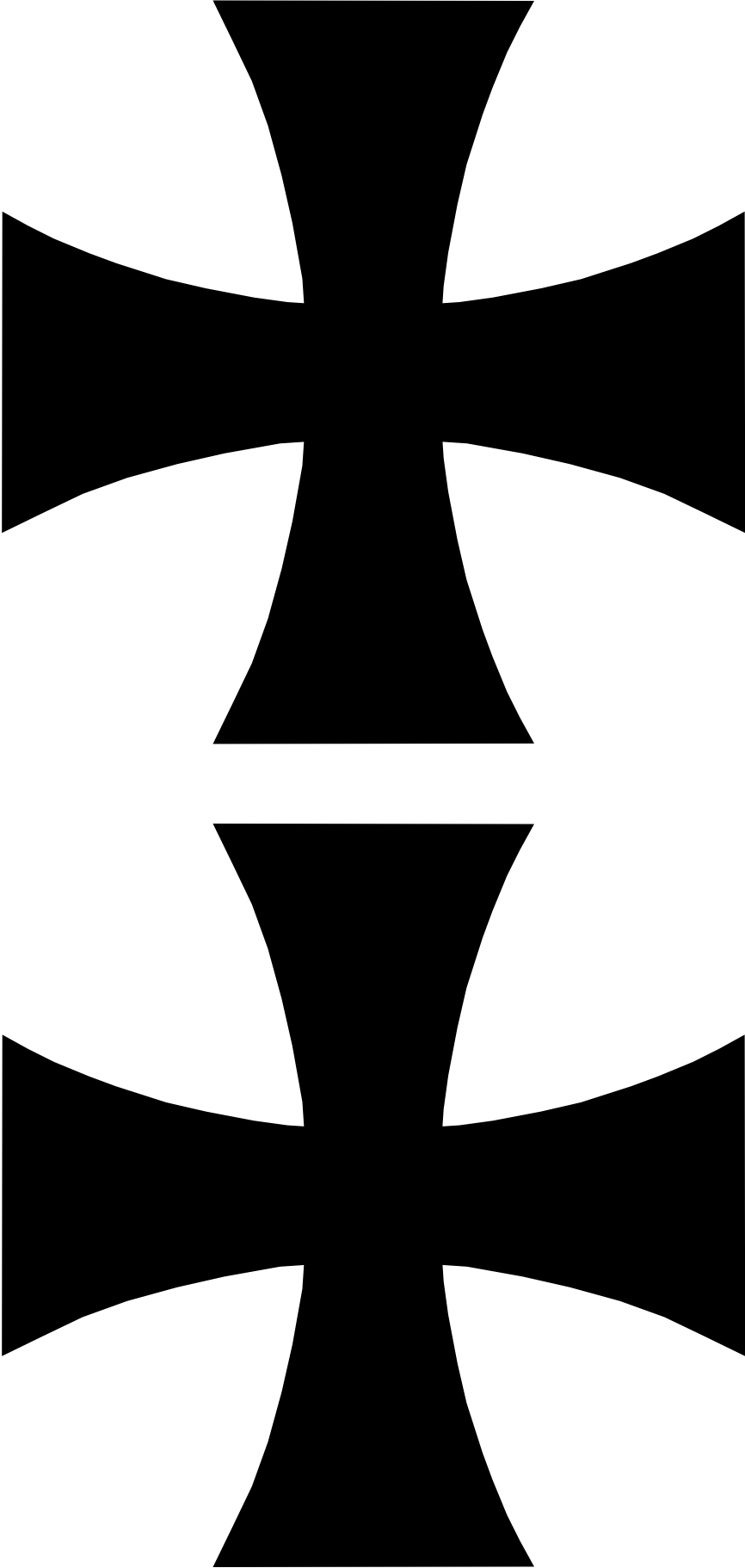

# Fokker DR1 Parkflyer

Designed by Steve Shumate  
Copyright © 2005 All Rights Reserved

All parts are made from 6 mm Depron or BlueCore foam unless otherwise specified

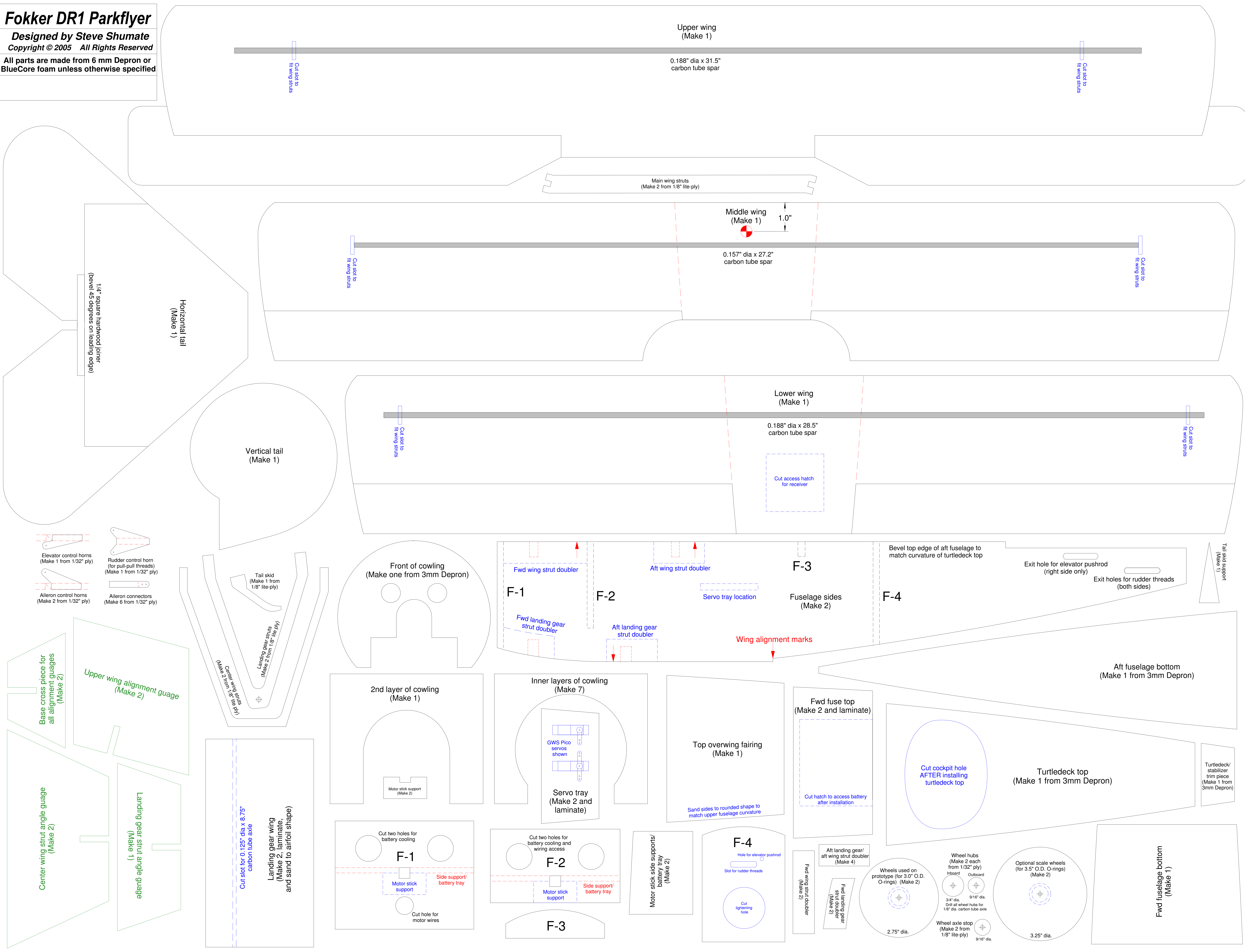

Upper wing  
(Make 1)

0.188" dia x 31.5"  
carbon tube spar

Cut slot to  
fit wing struts

Cut slot to  
fit wing struts

Main wing struts  
(Make 2 from 1/8" lite-ply)

Middle wing  
(Make 1)

1.0"

0.157" dia x 27.2"  
carbon tube spar

Cut slot to  
fit wing struts

Cut slot to  
fit wing struts

Horizontal tail  
(Make 1)

1/4" square hardwood joiner  
(bevel 45 degrees on leading edge)

Vertical tail  
(Make 1)

Lower wing  
(Make 1)

0.188" dia x 28.5"  
carbon tube spar

Cut slot to  
fit wing struts

Cut slot to  
fit wing struts

Cut access hatch  
for receiver

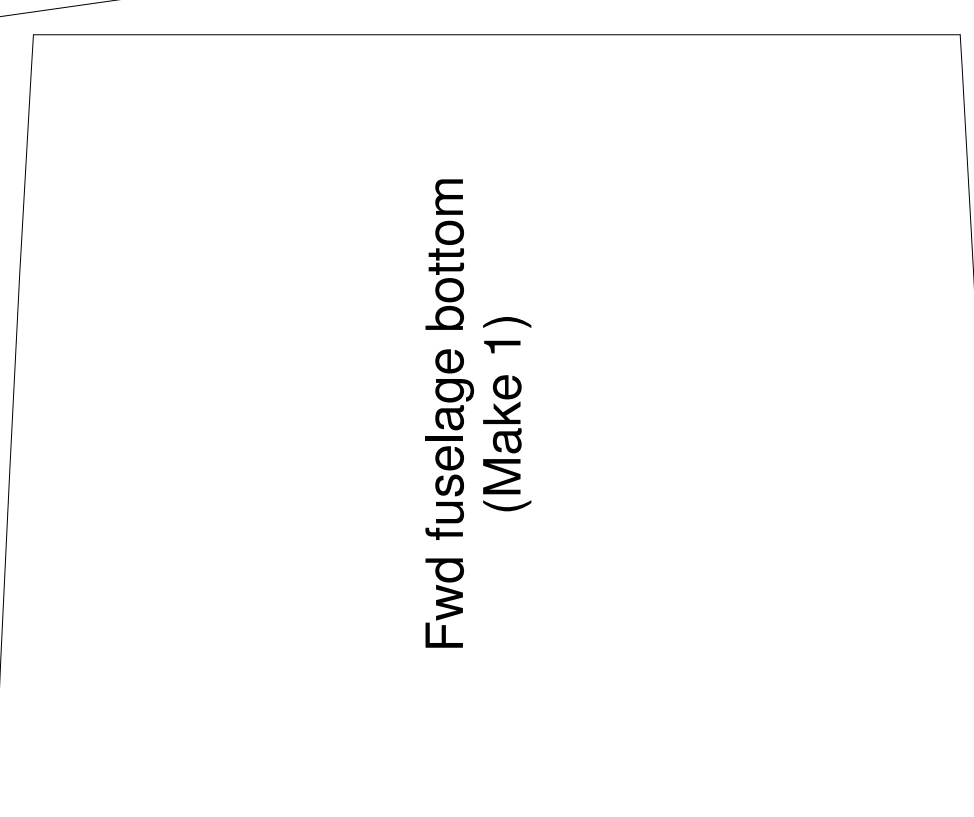
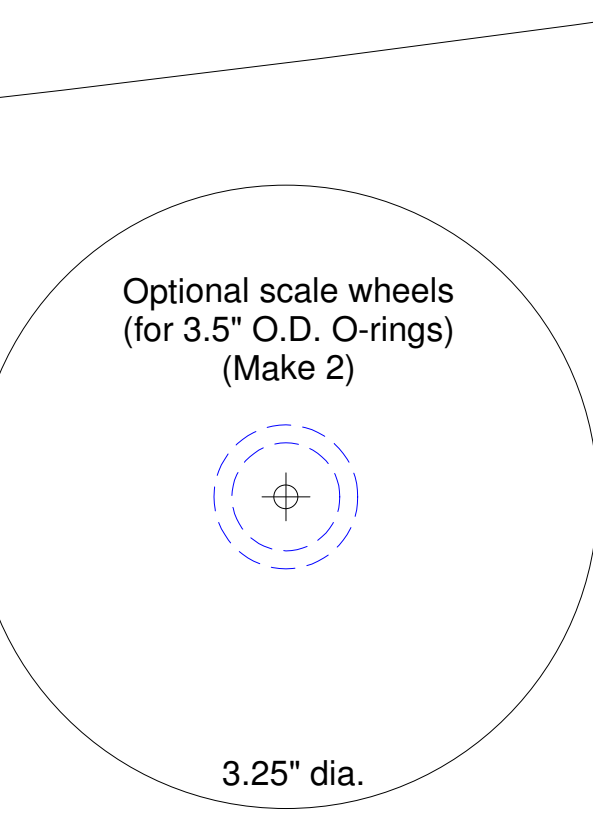
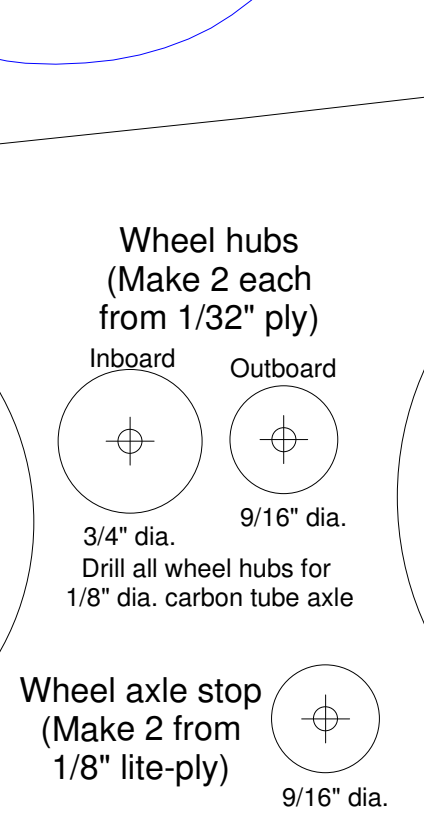
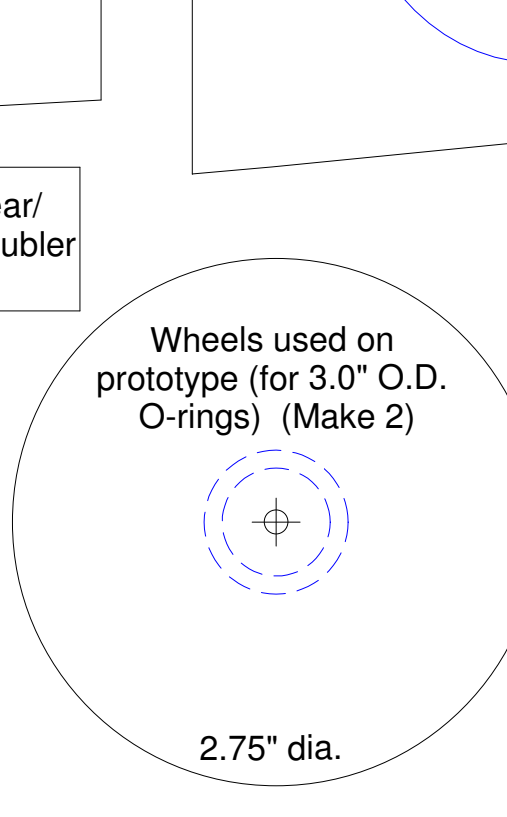
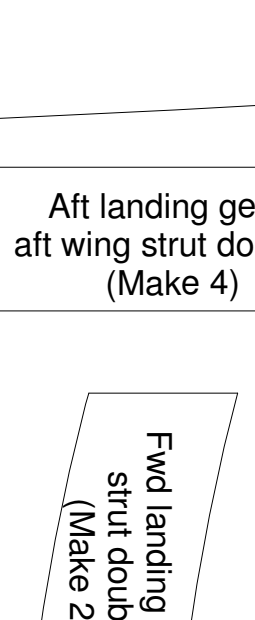
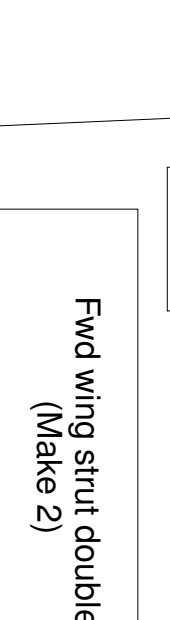
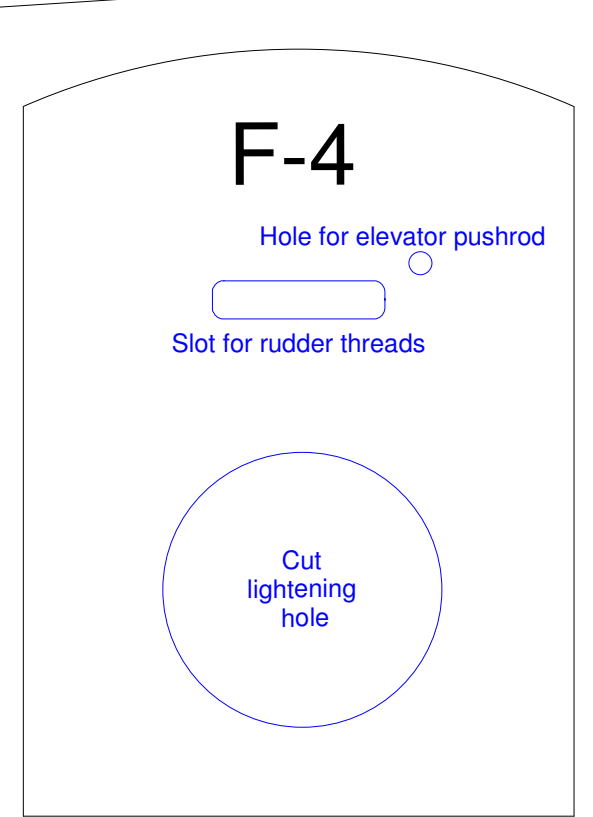
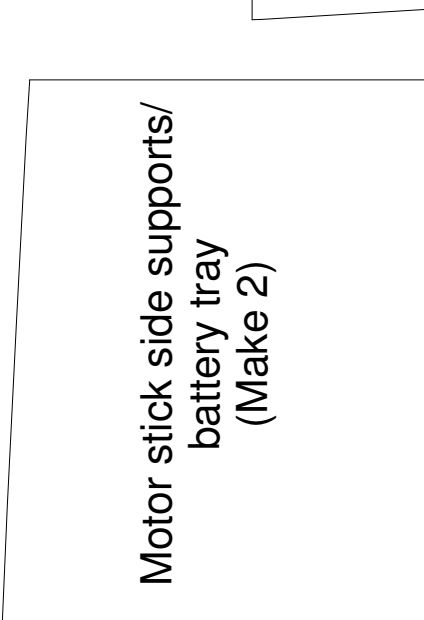
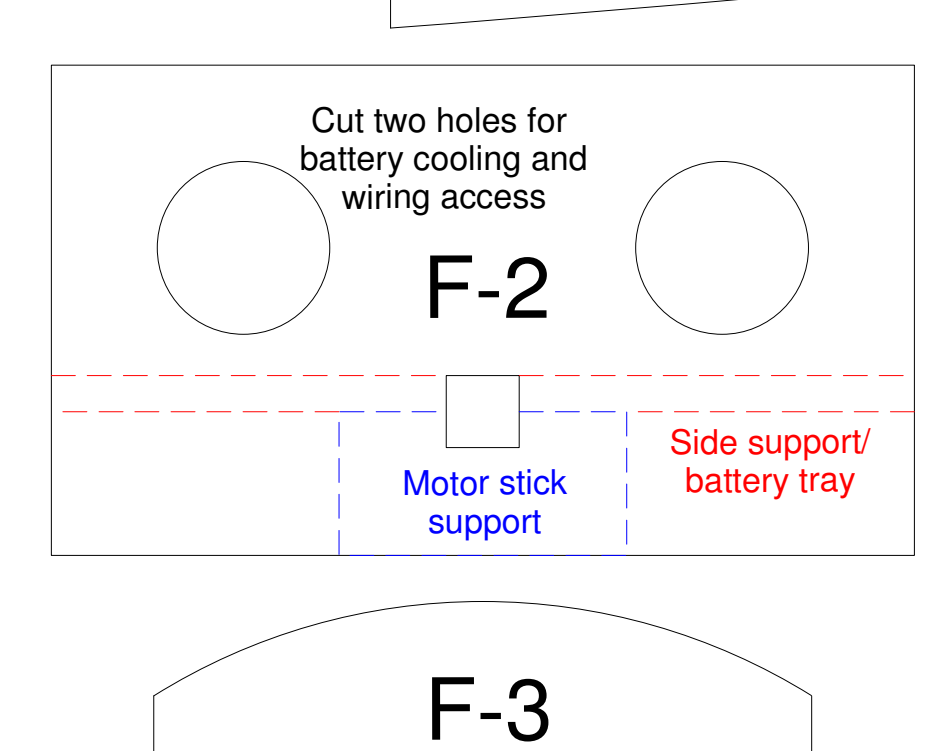
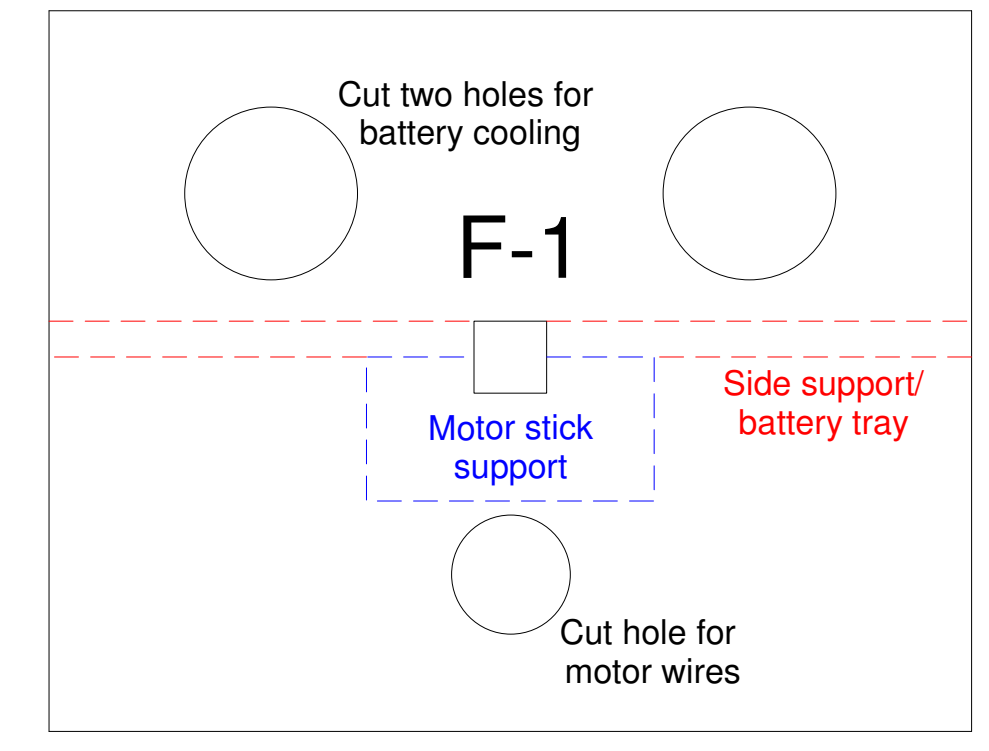
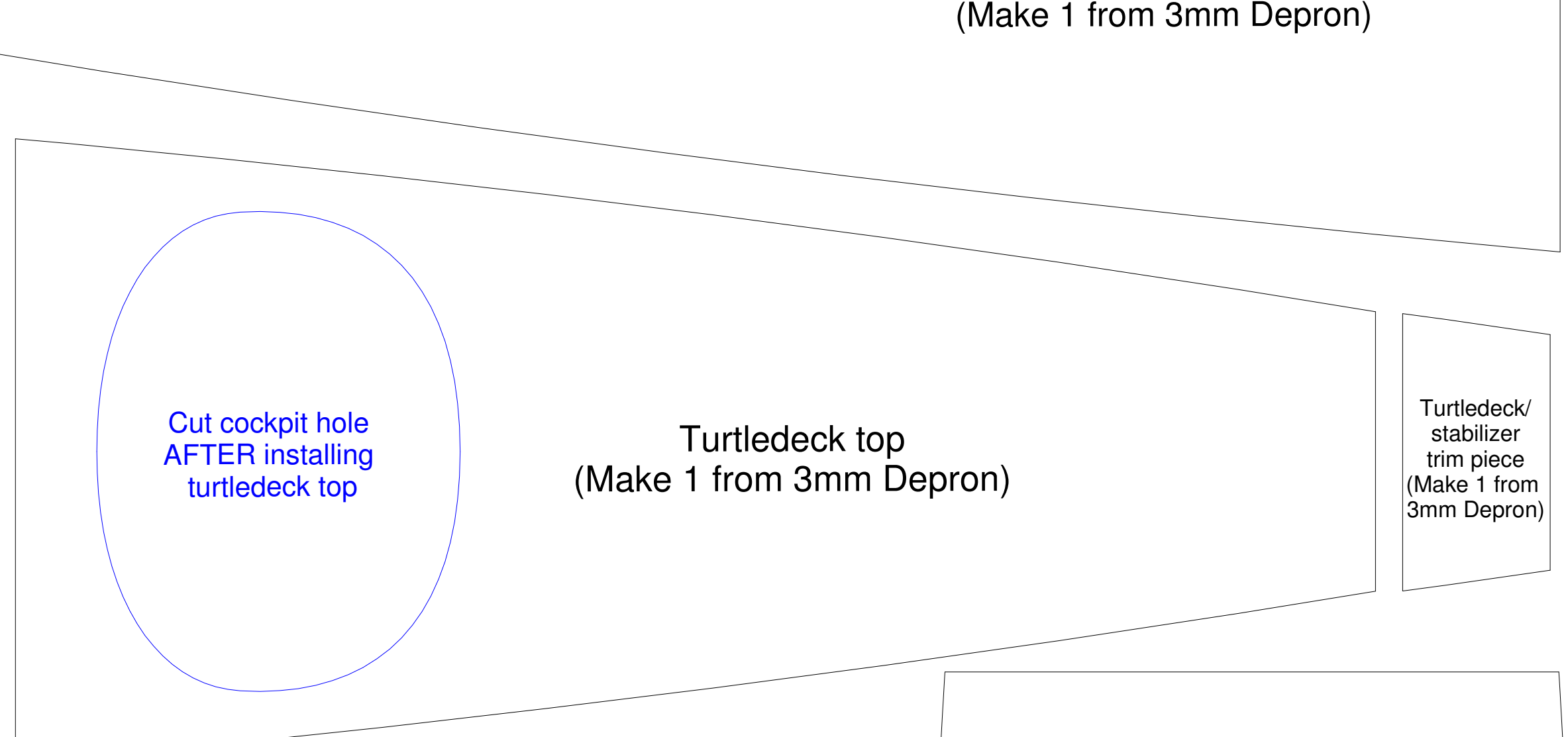
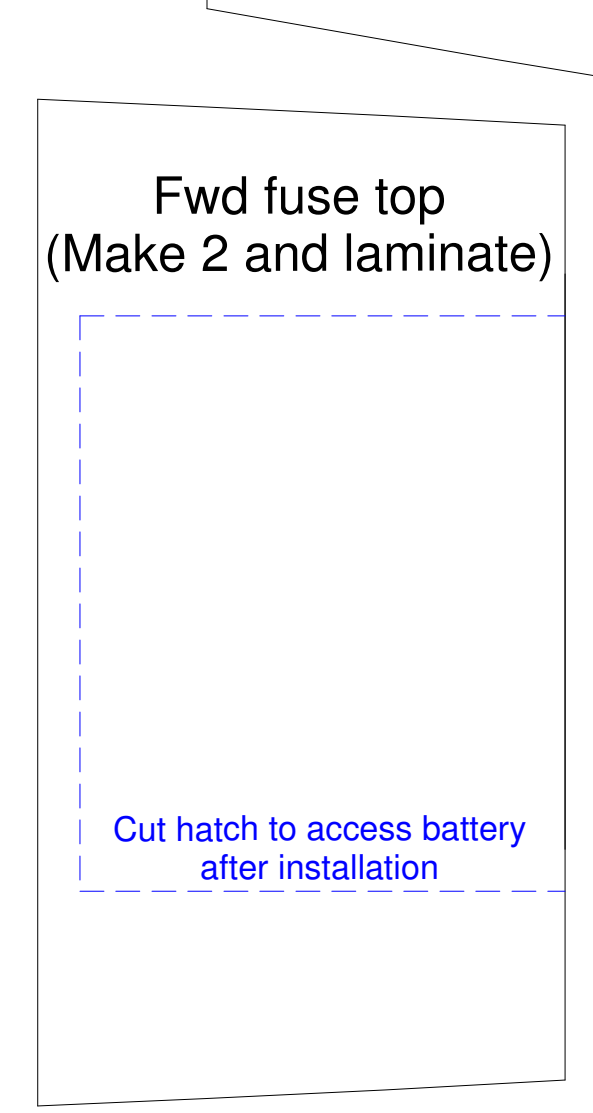
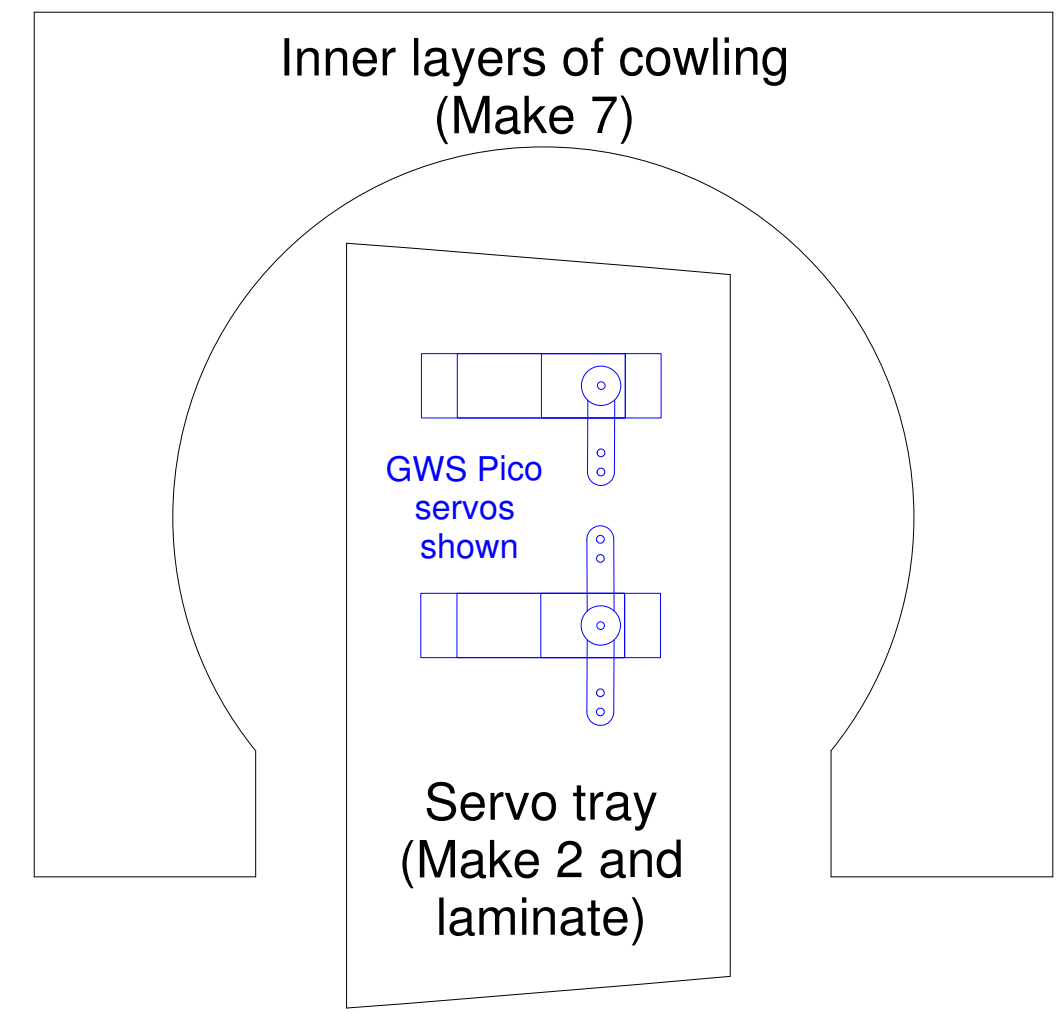
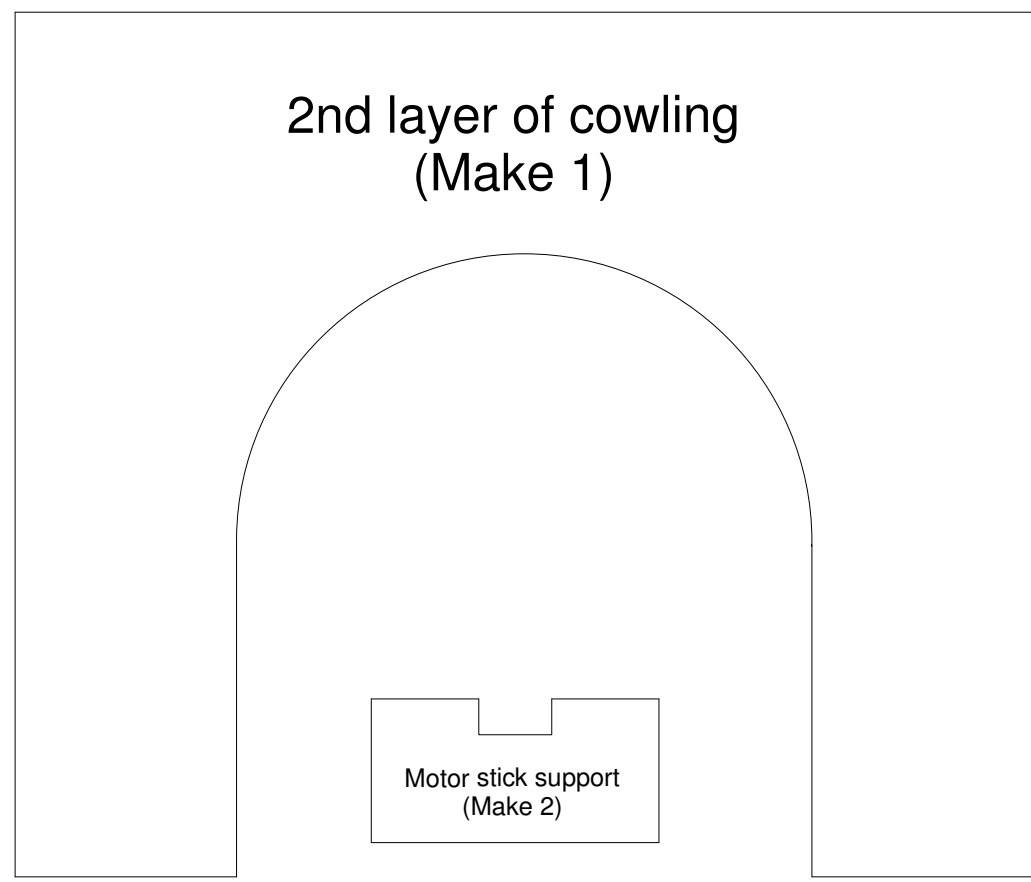
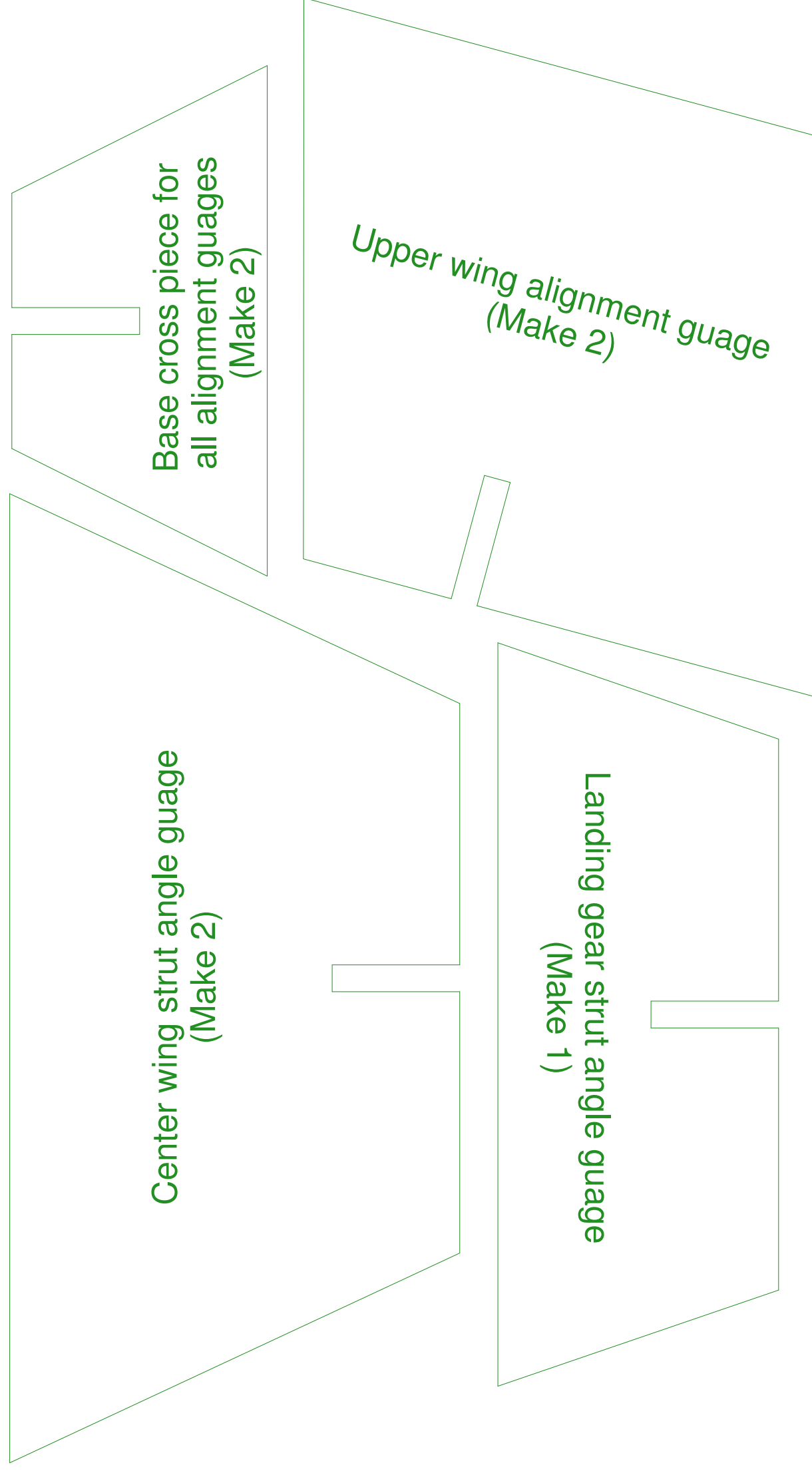
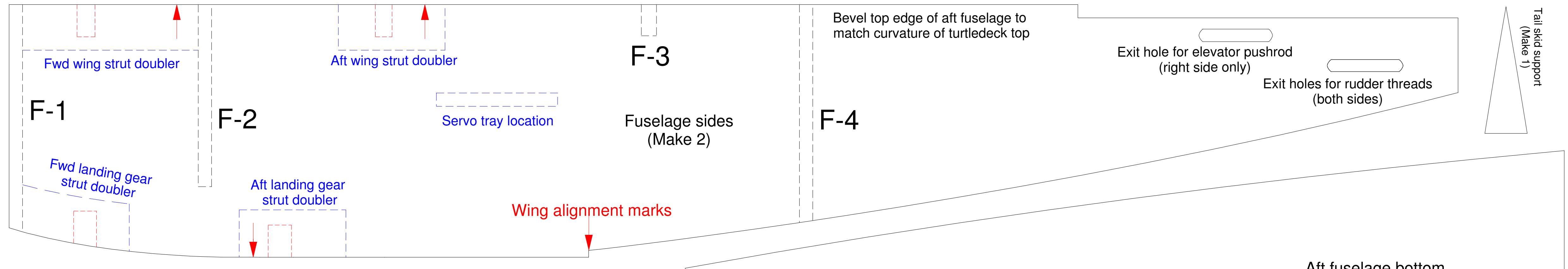
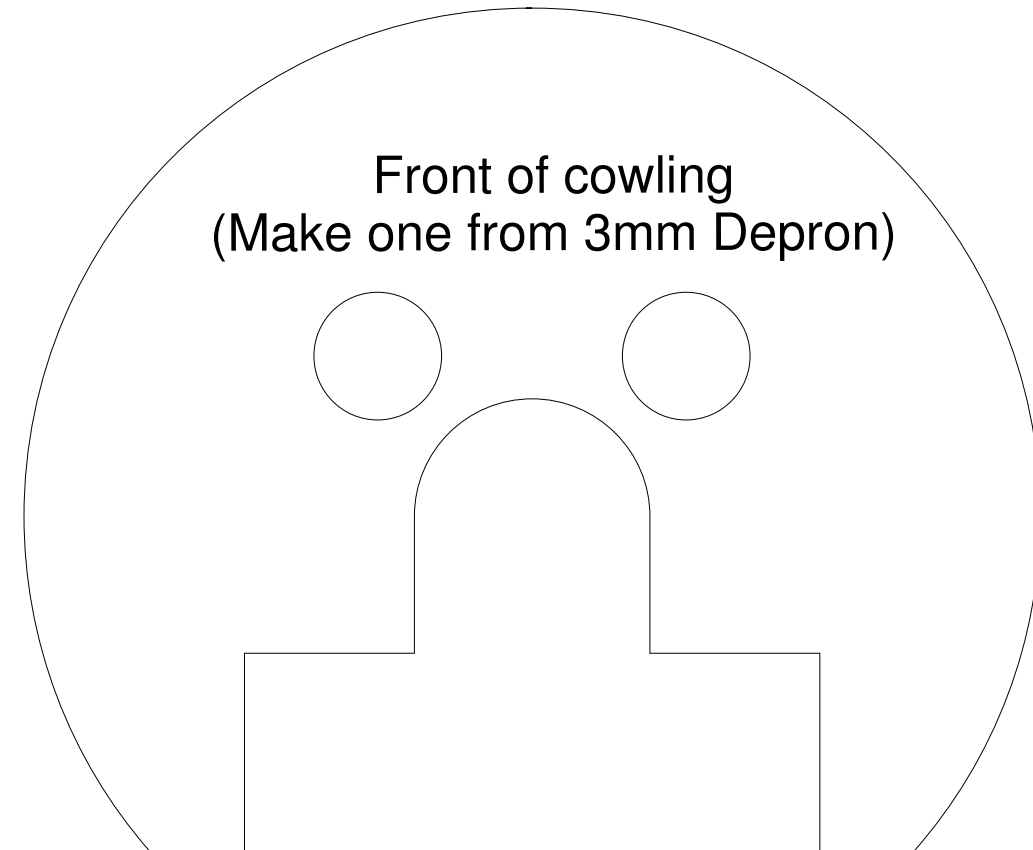
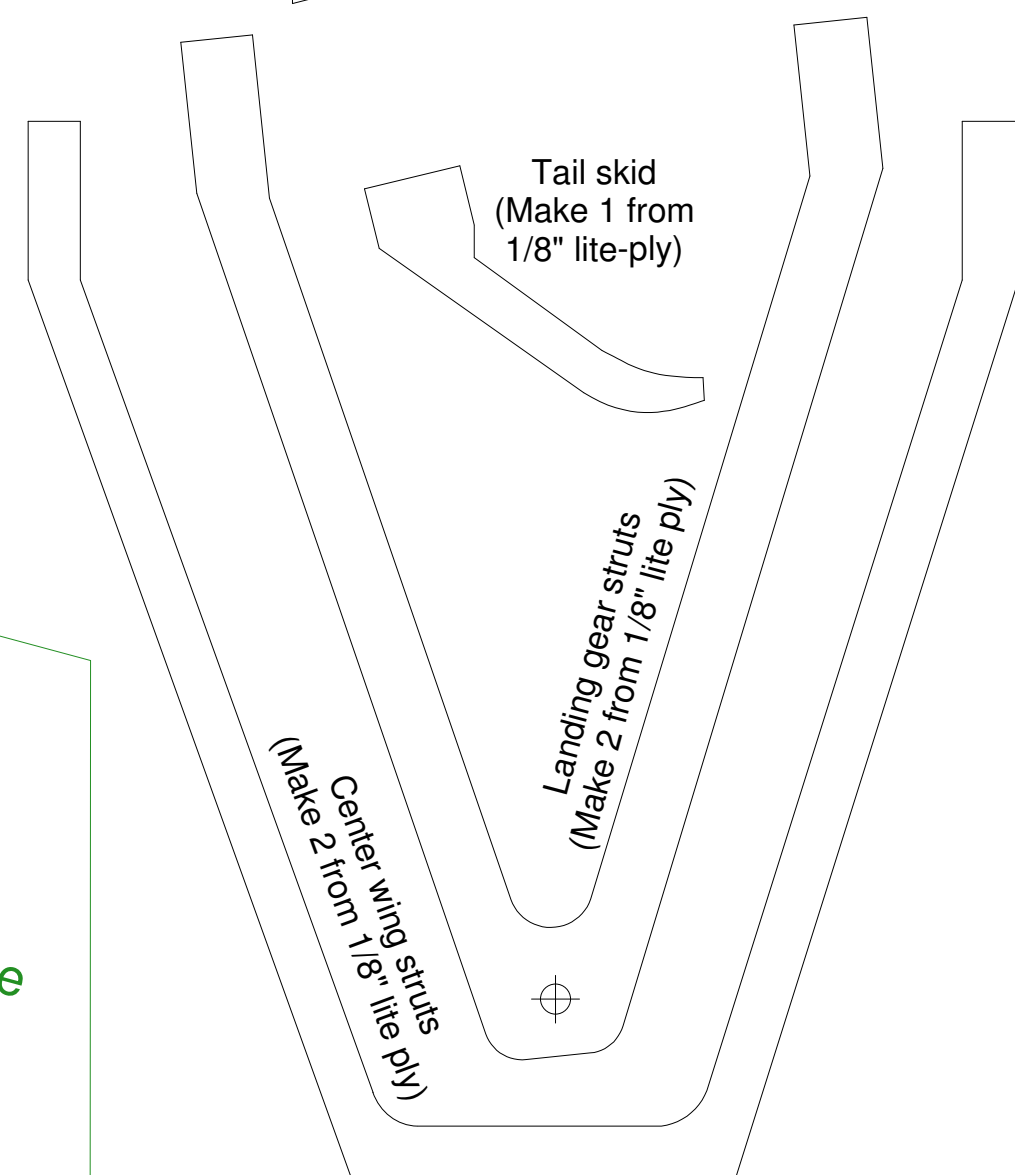
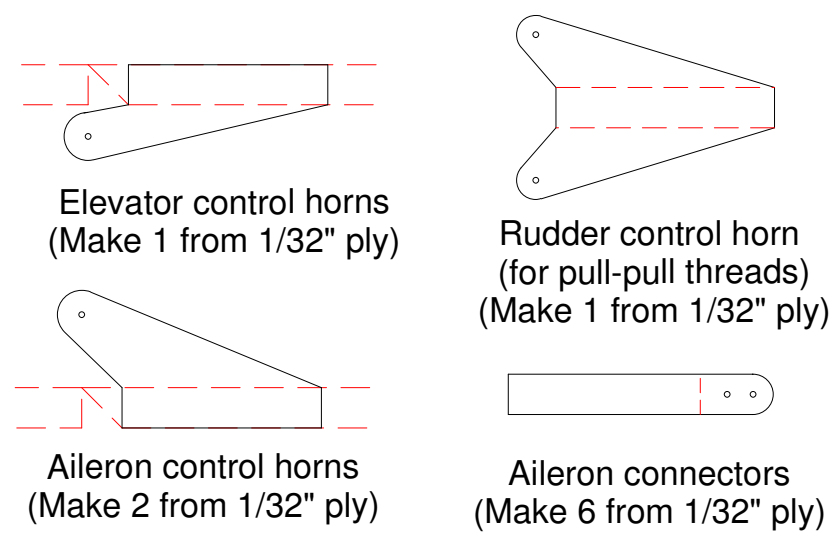

Center wing strut angle guage  
(Make 2)

Base cross piece for  
all alignment guages  
(Make 2)

Upper wing alignment guage  
(Make 2)

Landing gear strut angle guage  
(Make 1)

Cut slot for 0.125" dia x 8.75"  
carbon tube axle

Landing gear wing  
(Make 2, laminate,  
and sand to airfoil shape)

Center wing struts  
(Make 2 from 1/8" lite ply)

Landing gear  
(Make 2 from 1/8"

2nd layer of  
(Make

Motor stick s  
(Make

Cut two holes  
battery cool

Motor s  
supp

wing alignment marks

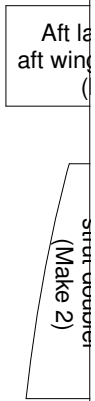
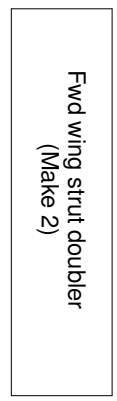
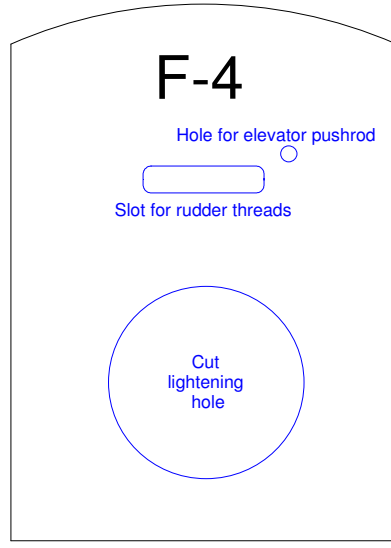
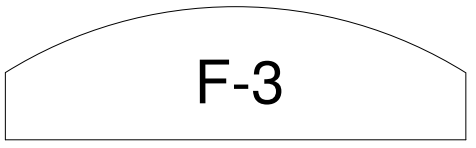
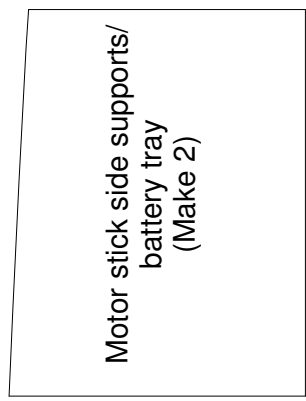
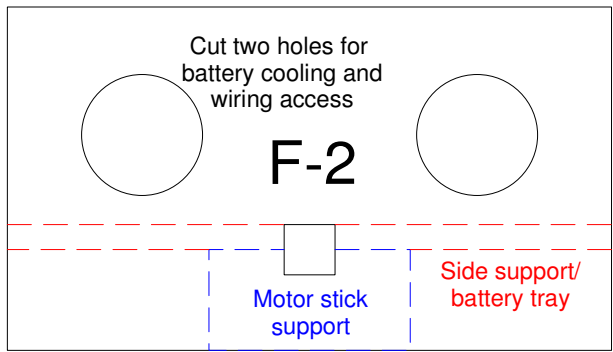
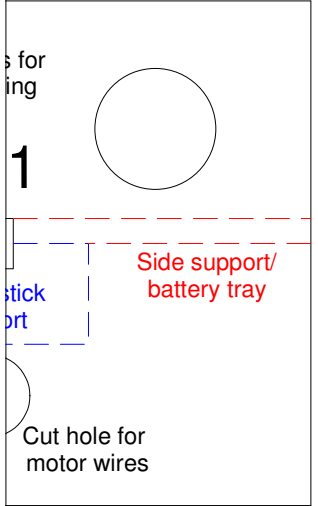
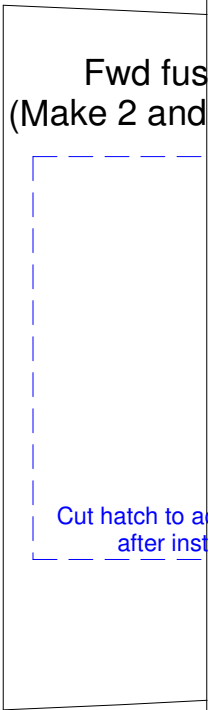
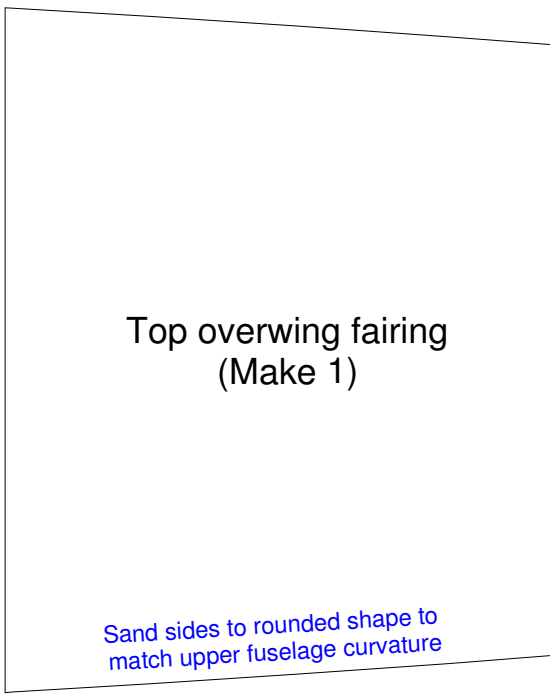
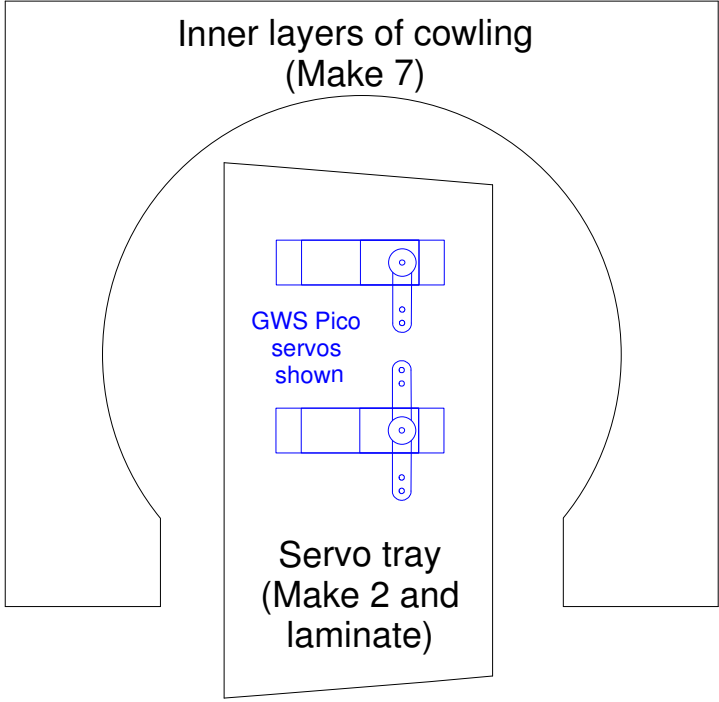
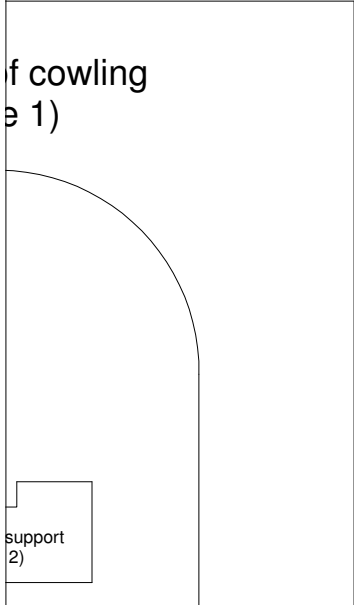

Aft fuselage bottom  
(Make 1 from 3mm Depron)

the top  
laminates)

Cut cockpit hole  
AFTER installing  
turtledeck top

Turtledeck top  
(Make 1 from 3mm Depron)

Turtledeck/  
stabilizer  
trim piece  
(Make 1 from  
3mm Depron)

Access battery  
installation

Landing gear/  
strut doubler  
(Make 4)

Fwd landing gear  
strut doubler

Wheels used on  
prototype (for 3.0" O.D.  
O-rings) (Make 2)

2.75" dia.

Wheel hubs  
(Make 2 each  
from 1/32" ply)

Inboard

Outboard



3/4" dia.

9/16" dia.

Drill all wheel hubs for  
1/8" dia. carbon tube axle

Wheel axle stop  
(Make 2 from  
1/8" lite-ply)



9/16" dia.

Optional scale wheels  
(for 3.5" O.D. O-rings)  
(Make 2)

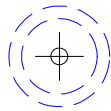

3.25" dia.

Fwd fuselage bottom  
(Make 1)

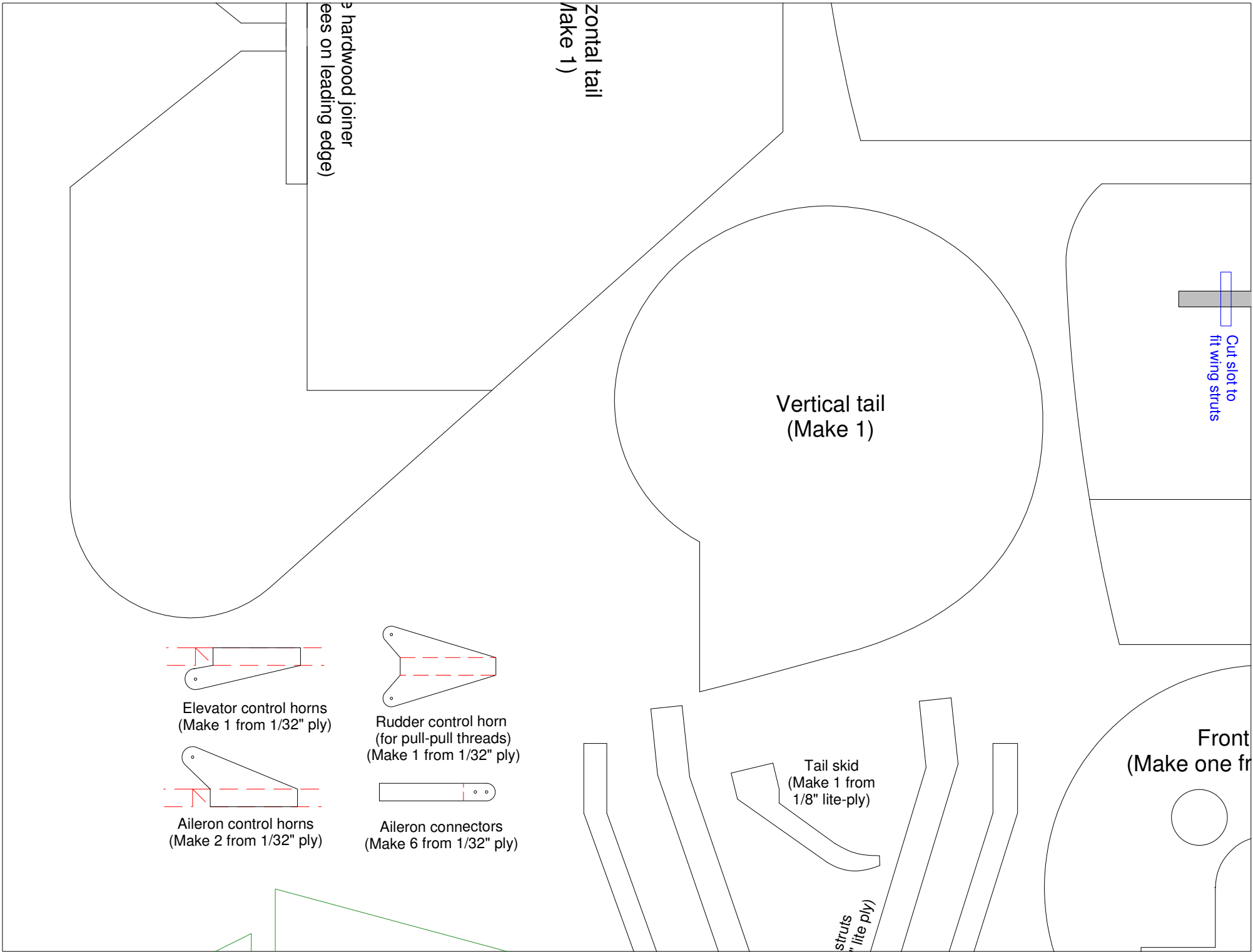

a hardwood joiner  
ees on leading edge)

zontal tail  
(Make 1)

Vertical tail  
(Make 1)

Cut slot to  
fit wing struts

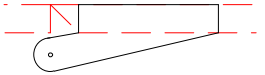

Elevator control horns  
(Make 1 from 1/32" ply)

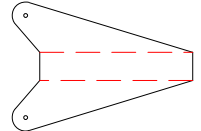

Rudder control horn  
(for pull-pull threads)  
(Make 1 from 1/32" ply)

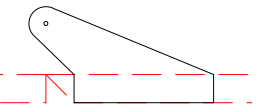

Aileron control horns  
(Make 2 from 1/32" ply)

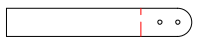

Aileron connectors  
(Make 6 from 1/32" ply)

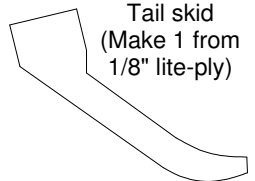

Tail skid  
(Make 1 from  
1/8" lite-ply)

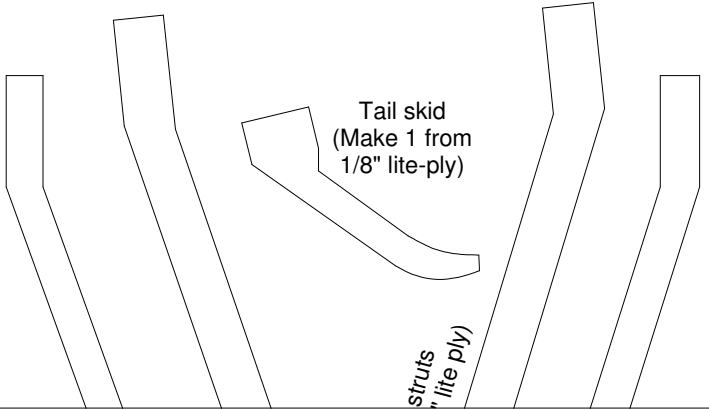

struts  
" lite ply)

Front  
(Make one fr

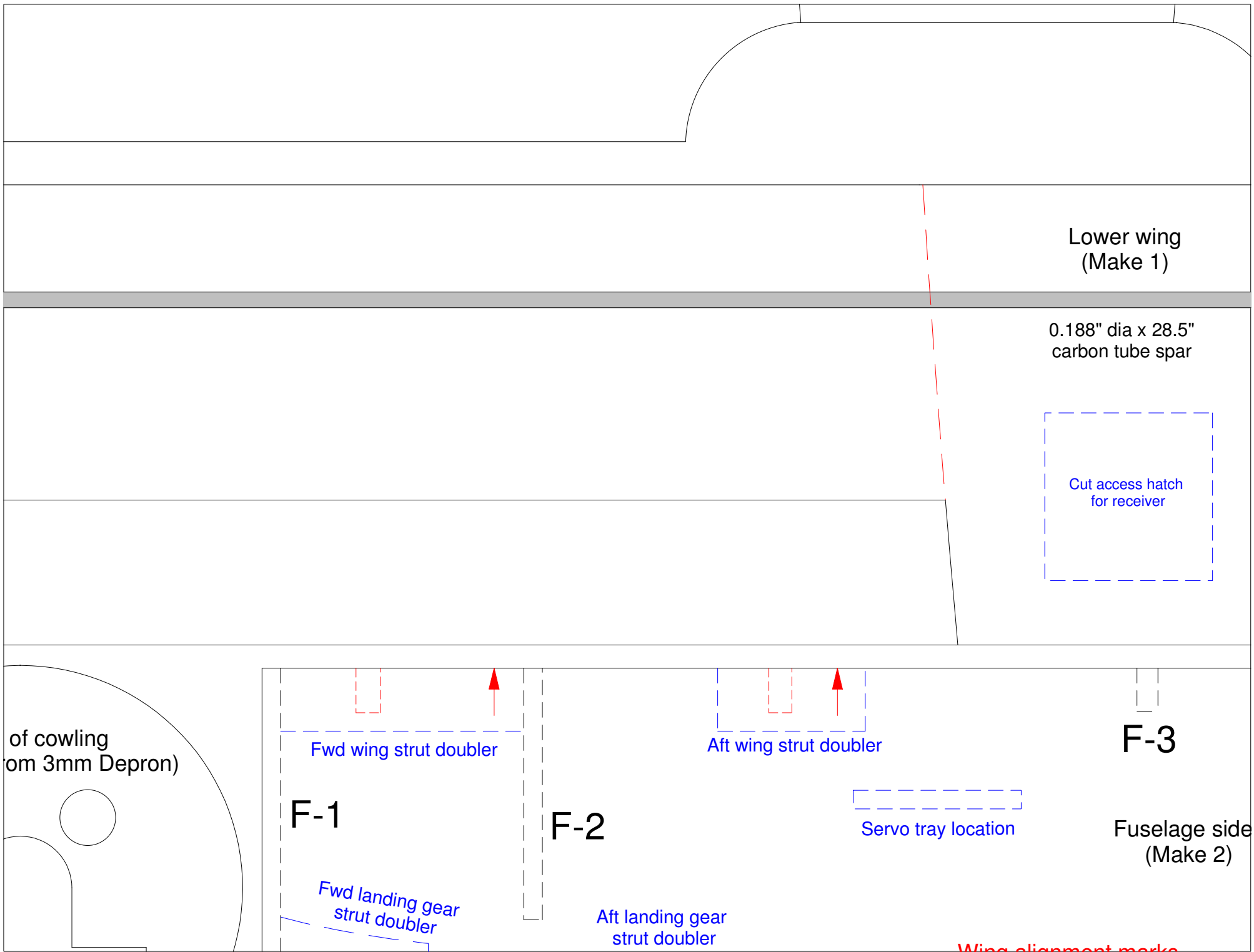

Lower wing  
(Make 1)

0.188" dia x 28.5"  
carbon tube spar



Cut access hatch  
for receiver

of cowling  
(om 3mm Depron)



Fwd wing strut doubler

F-1

Fwd landing gear  
strut doubler

Aft wing strut doubler

F-2

Aft landing gear  
strut doubler



Servo tray location

F-3

Fuselage side  
(Make 2)

Wing alignment marks

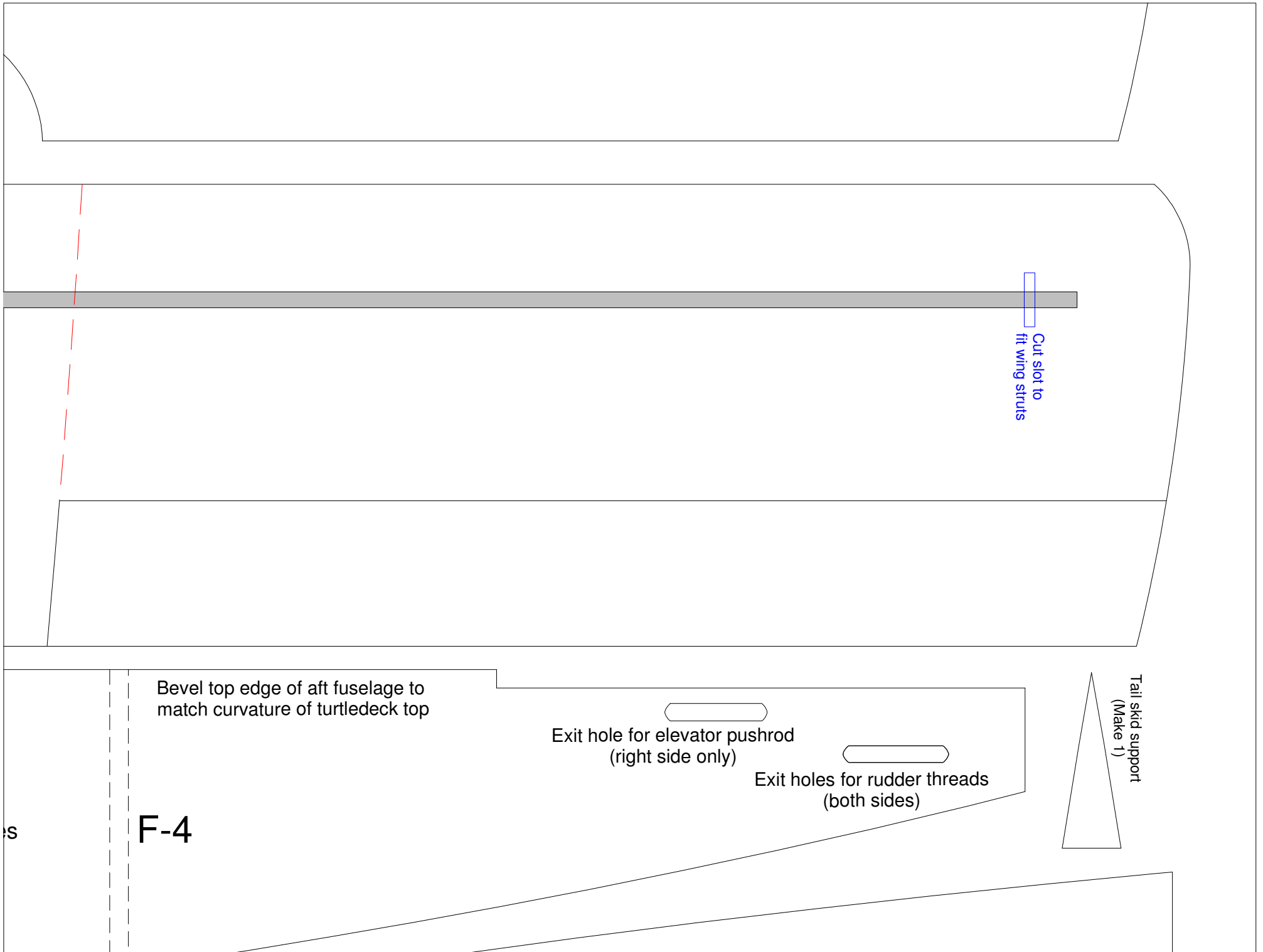

# Fokker DR1 Parkflyer

**Designed by Steve Shumate**  
**Copyright © 2005 All Rights Reserved**

**All parts are made from 6 mm Depron or BlueCore foam unless otherwise specified**

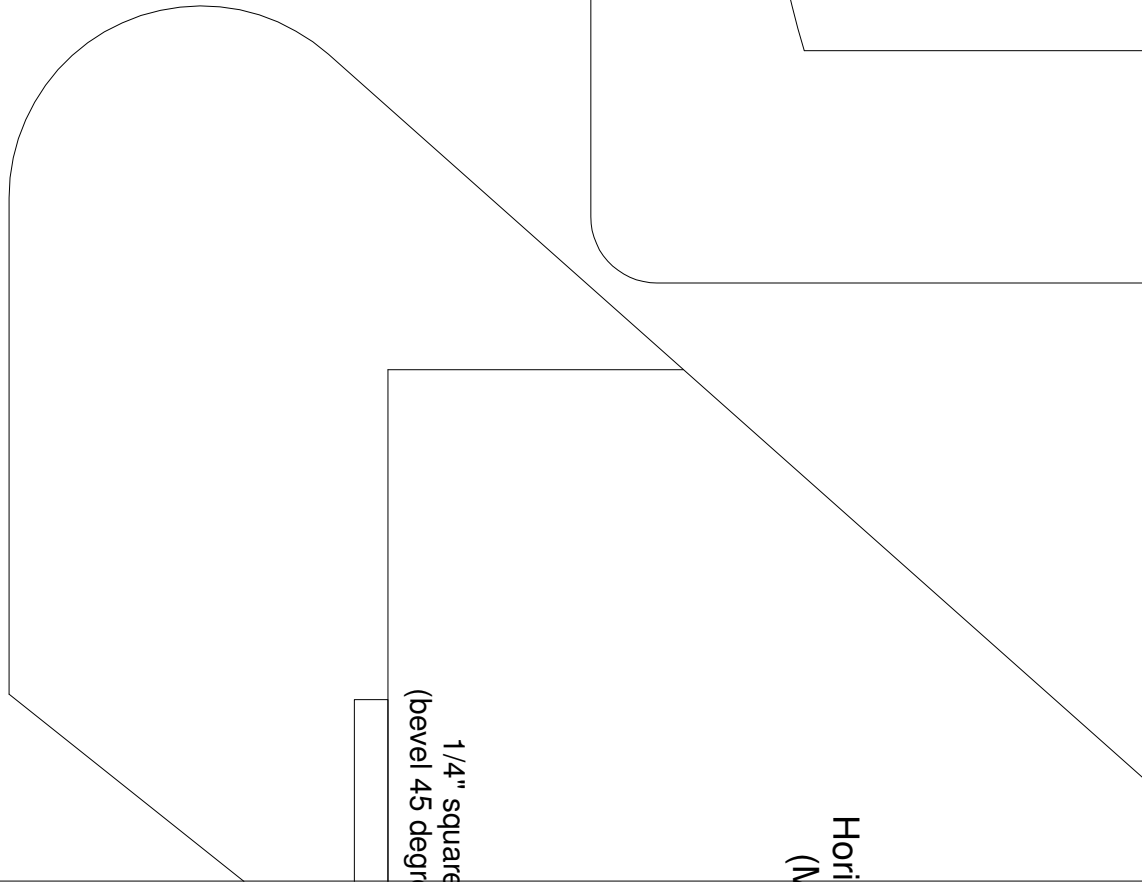

Cut slot to  
fit wing struts

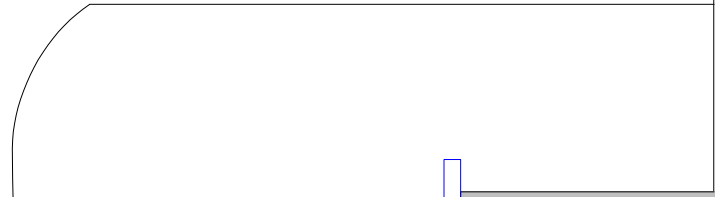

Cut slot to  
fit wing struts

Upper wing  
(Make 1)

0.188" dia x 31.5"  
carbon tube spar

***Plans Scaled 70%***

Main wing struts  
(Make 2 from 1/8" lite-ply)

0.7"

Middle wing  
(Make 1)



0.157" dia x 27.2"  
carbon tube spar

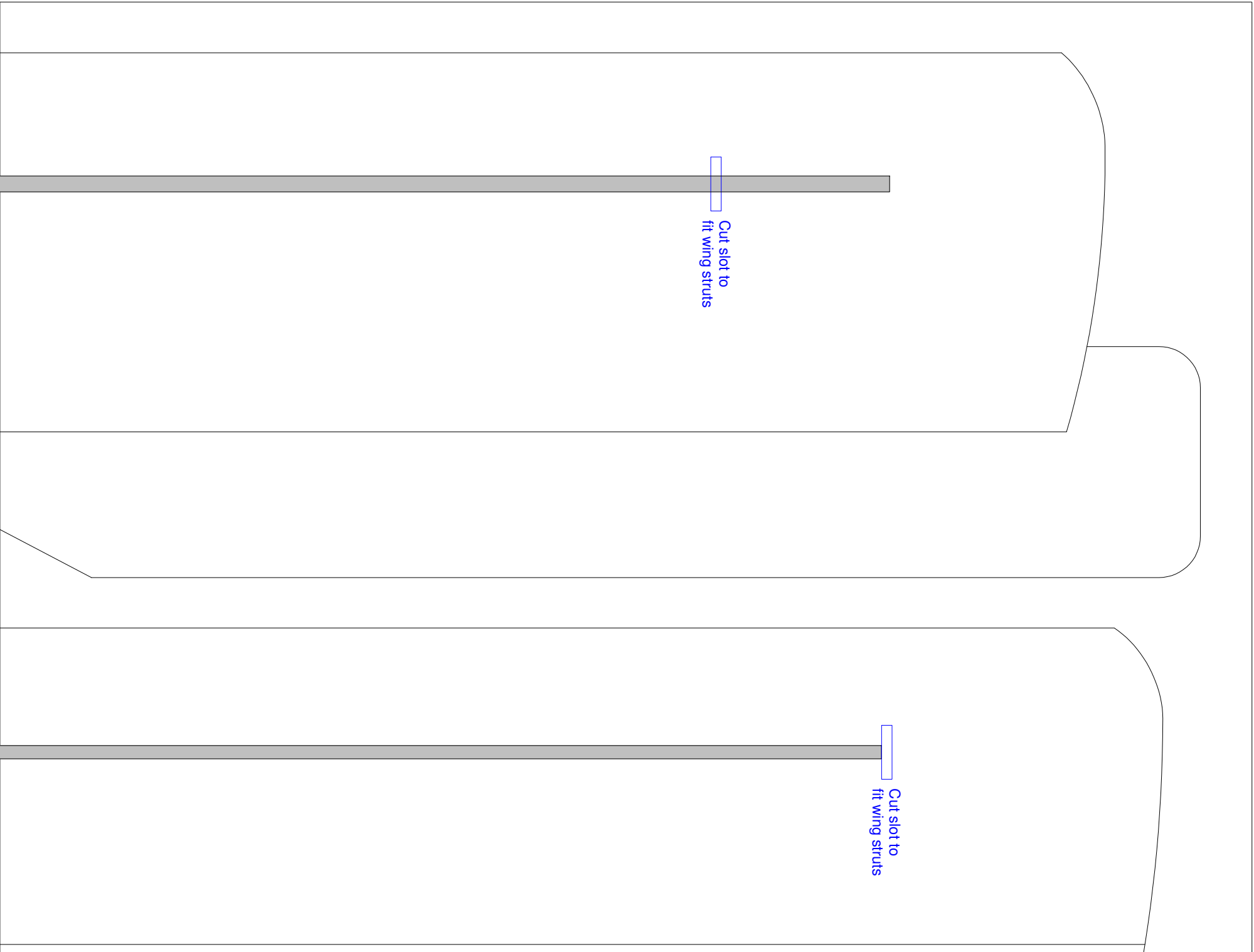

Center wing strut ar  
(Make 2)

gear strut angle guage  
(Make 1)

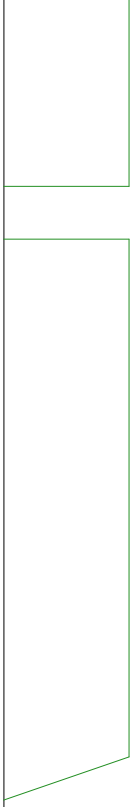

Cut slot for 0.125" dia x  
carbon tube axle

Landing gear win  
(Make 2, laminate  
and sand to airfoil sh

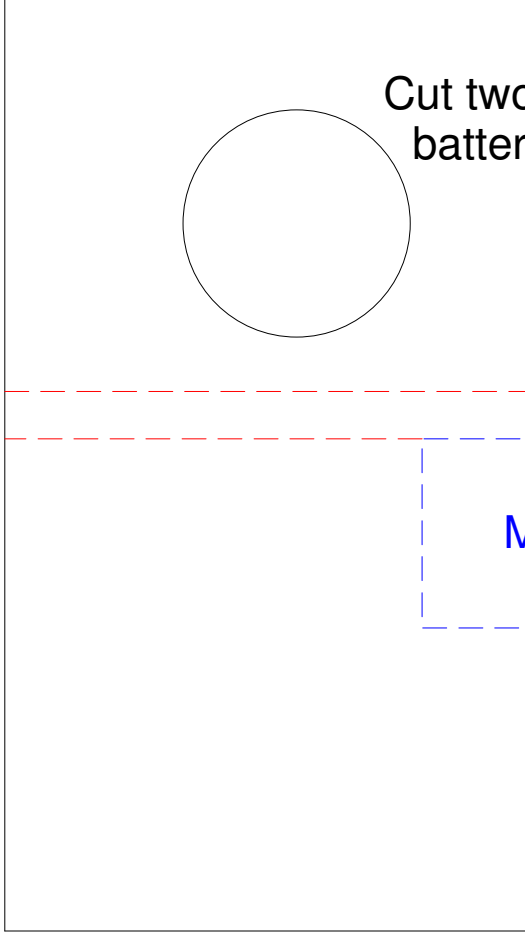

Cut two batter

M

Two holes for  
battery cooling

**F-1**

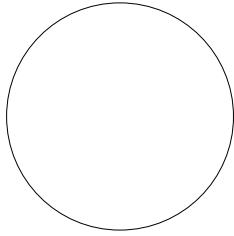

Motor stick  
support



Side support/  
battery tray

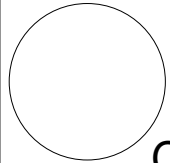

Cut hole for  
motor wires

Cut two holes for  
battery cooling and  
wiring access

**F-2**

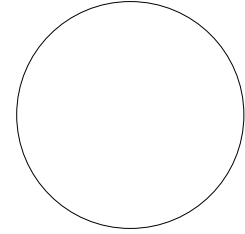
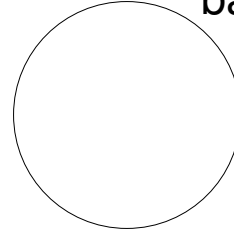

Motor stick  
support

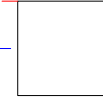

Side support/  
battery tray

**F-3**

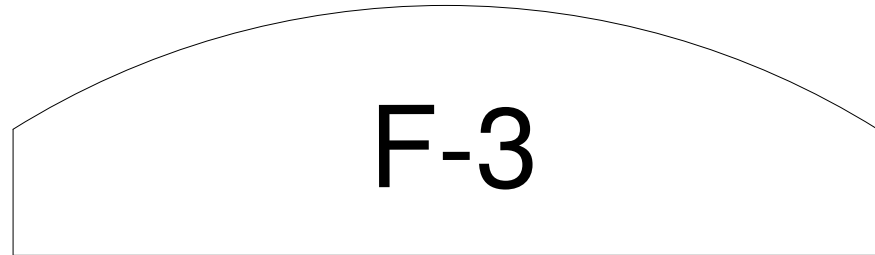

Motor stick side supports/  
battery tray  
(Make 2)

# F-4

Hole for elevator pushrod



Slot for rudder threads



Cut  
lightening  
hole

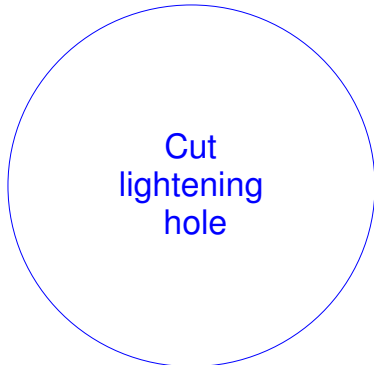

Fwd wing strut doubler  
(Make 2)

Aft landing  
aft wing strut  
(Make

Fwd landing gear  
strut doubler  
(Make 2)

gear/  
doubler  
4)

Wheels used on  
prototype (for 3.0" O.D.  
O-rings) (Make 2)

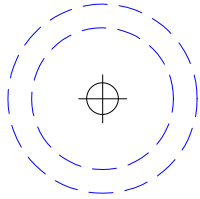

2.75" dia.

Wheel hubs  
(Make 2 each  
from 1/32" ply)

Inboard

Outboard

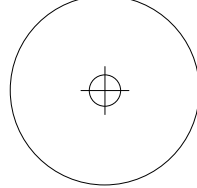

3/4" dia.

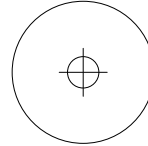

9/16" dia.

Drill all wheel hubs for  
1/8" dia. carbon tube axle

Wheel axle stop  
(Make 2 from  
1/8" lite-ply)

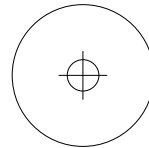

9/16" dia.

Optional scale wheels  
(for 3.5" O.D. O-rings)  
(Make 2)

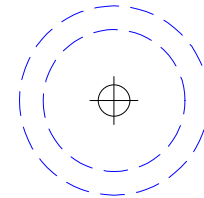

3.25" dia.



Fwd fuselage bottom  
(Make 1)

ngle guage

Base cross piece for  
all alignment guages  
(Make 2)

Upper wing alignment gu  
(Make 2)

Landing

age

Center wing struts  
(Make 2 from 1/8" lite ply)

Landing  
(Make 2 from



8.75"

ing  
e,  
ape)

2nd lay  
(M

Mot

er of cowling  
(Make 1)

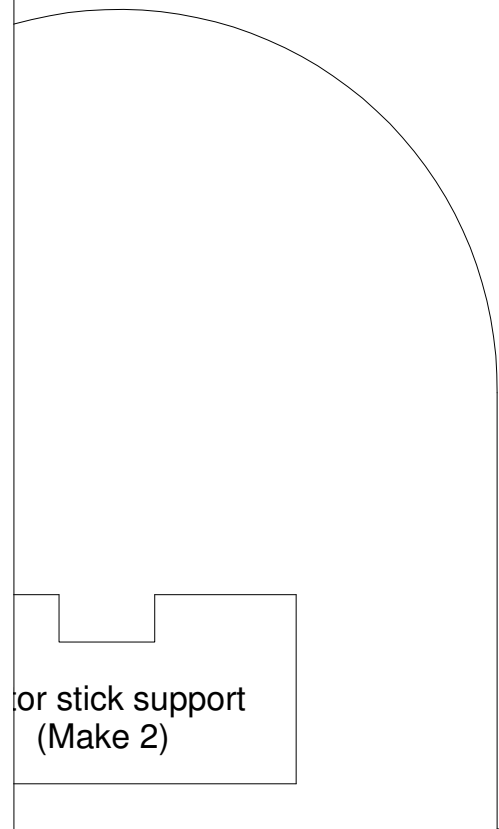

or stick support  
(Make 2)

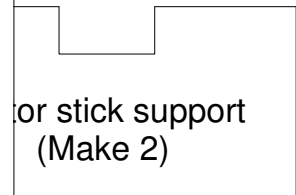

Inner layers of cowling  
(Make 7)

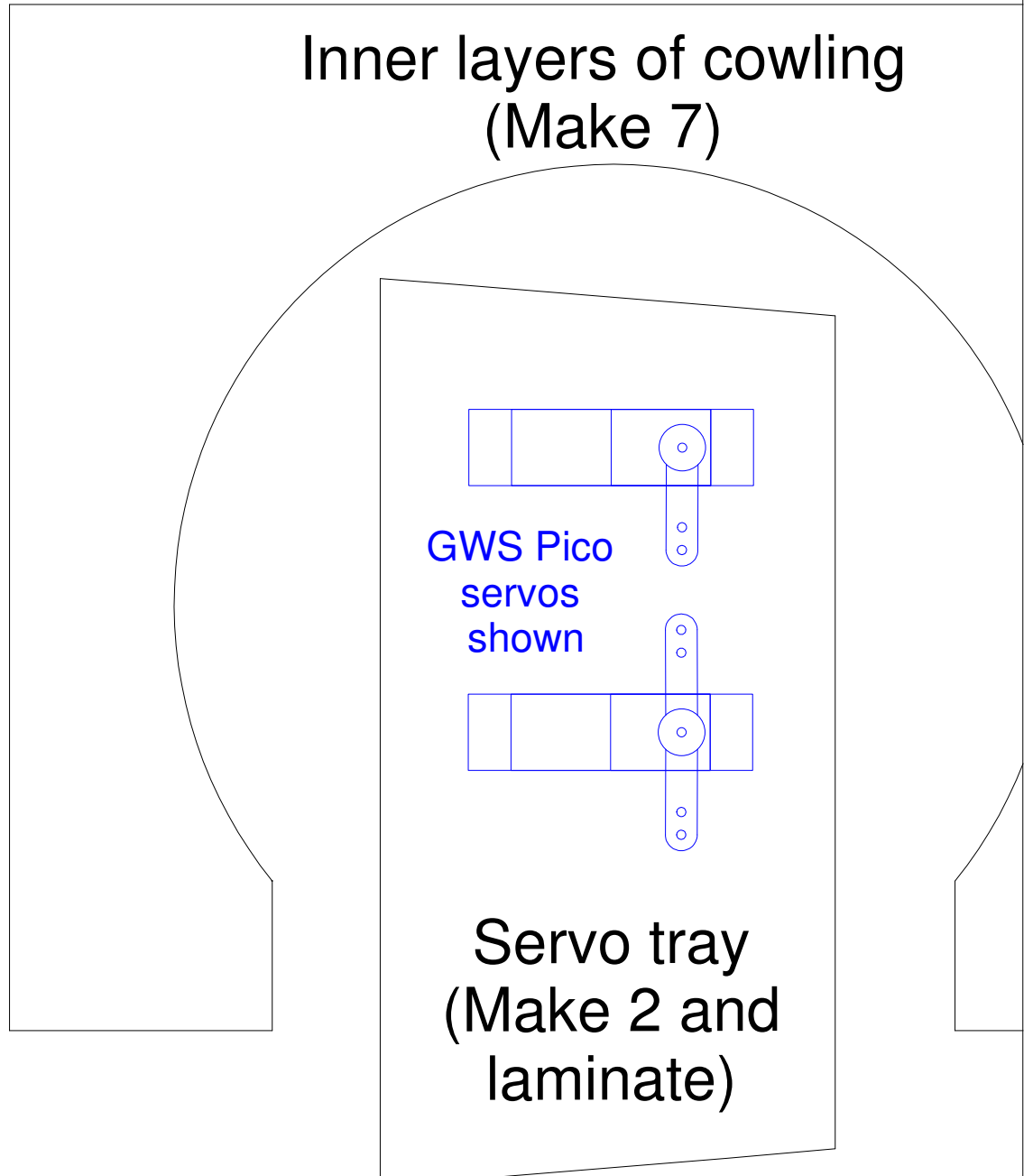

GWS Pico  
servos  
shown

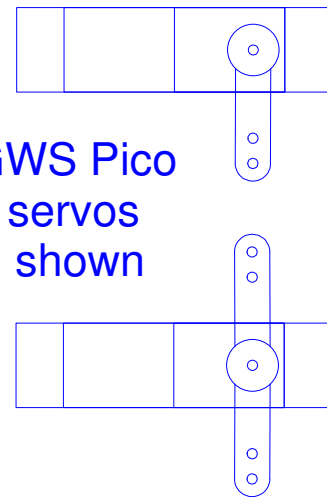

Servo tray  
(Make 2 and  
laminates)

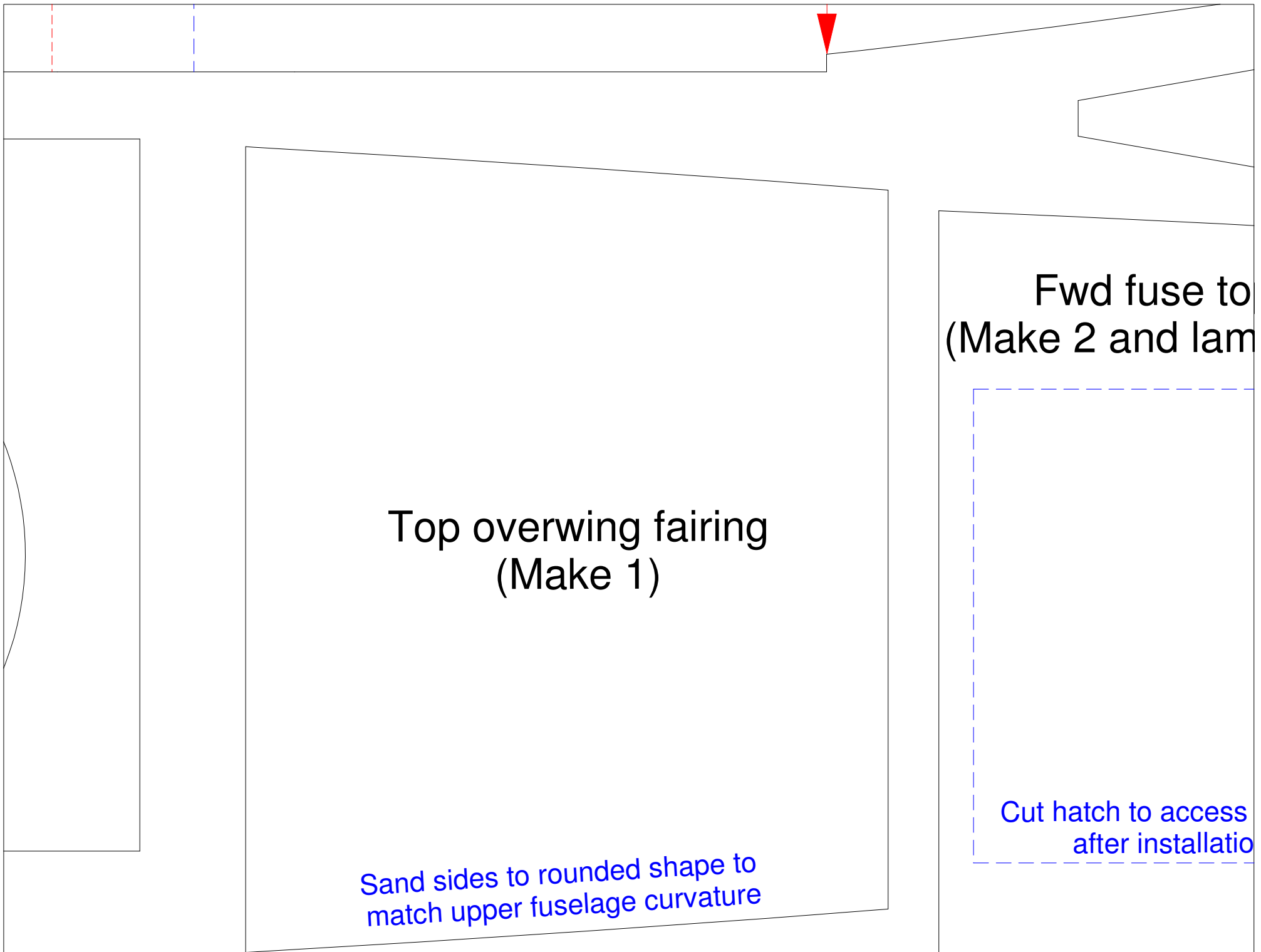

Top overwing fairing  
(Make 1)

Fwd fuse to  
(Make 2 and lam

Cut hatch to access  
after installatio

Sand sides to rounded shape to  
match upper fuselage curvature

p  
minate)

battery  
n

Cut cockpit hole  
AFTER installing  
turtledeck top

Turtledeck t  
(Make 1 from 3mm

Aft fuselage bottom  
(Make 1 from 3mm Depron)

op  
(Make 1 from 3mm Depron)

Turtledeck/  
stabilizer  
trim piece  
(Make 1 from  
3mm Depron)

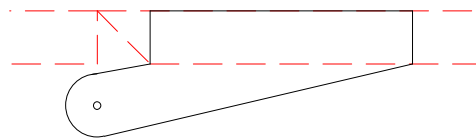

Elevator control horns  
(Make 1 from 1/32" ply)

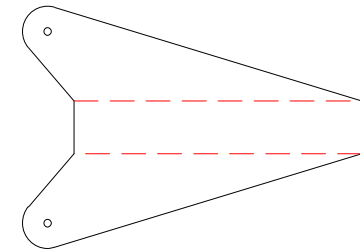

Rudder control horn  
(for pull-pull threads)  
(Make 1 from 1/32" ply)

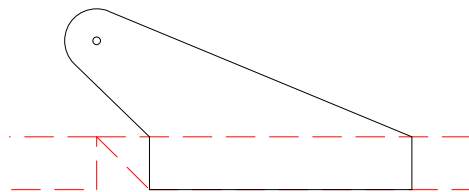

Aileron control horns  
(Make 2 from 1/32" ply)



Aileron connectors  
(Make 6 from 1/32" ply)

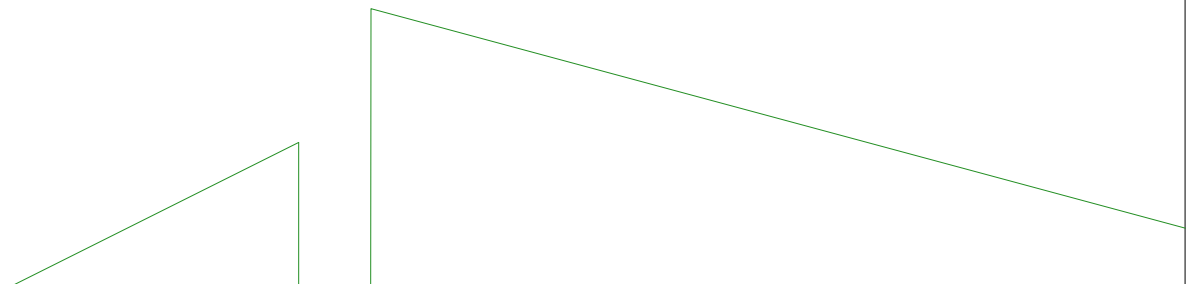

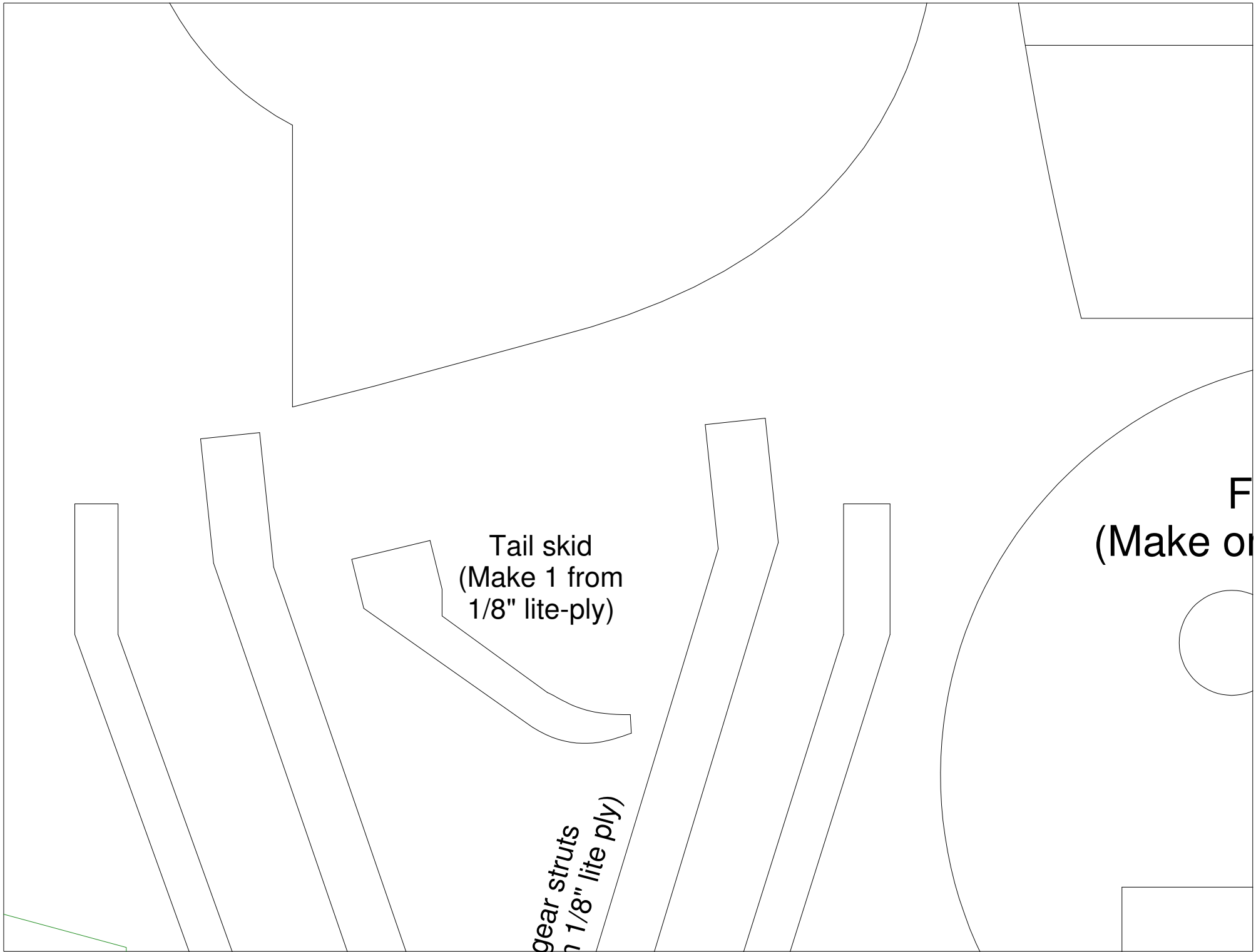

Tail skid  
(Make 1 from  
1/8" lite-ply)

*gear struts  
1/8" lite ply*

F  
(Make on

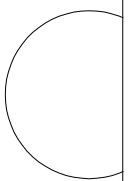

Front of cowling  
(made from 3mm Depron)

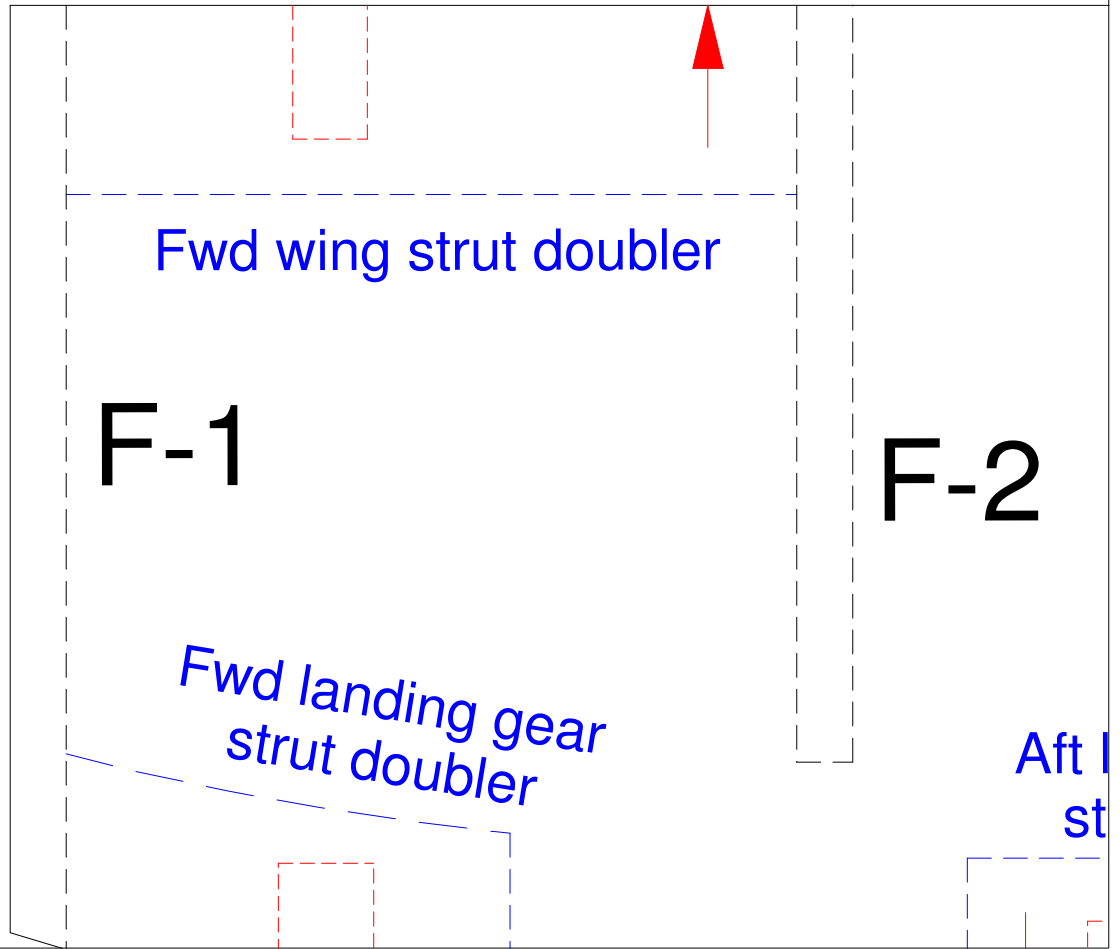
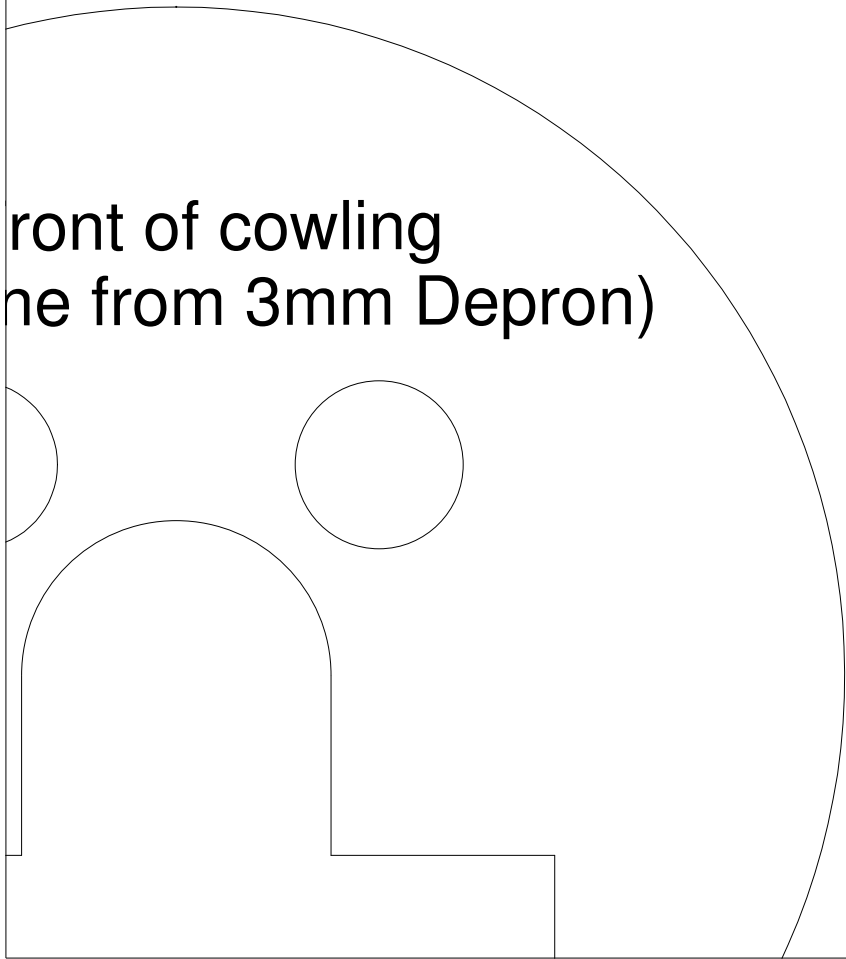

Cut access hatch  
for receiver

Aft wing strut doubler

F-3

Servo tray location

Fuselage sides  
(Make 2)

Landing gear  
strut doubler

Wing alignment marks

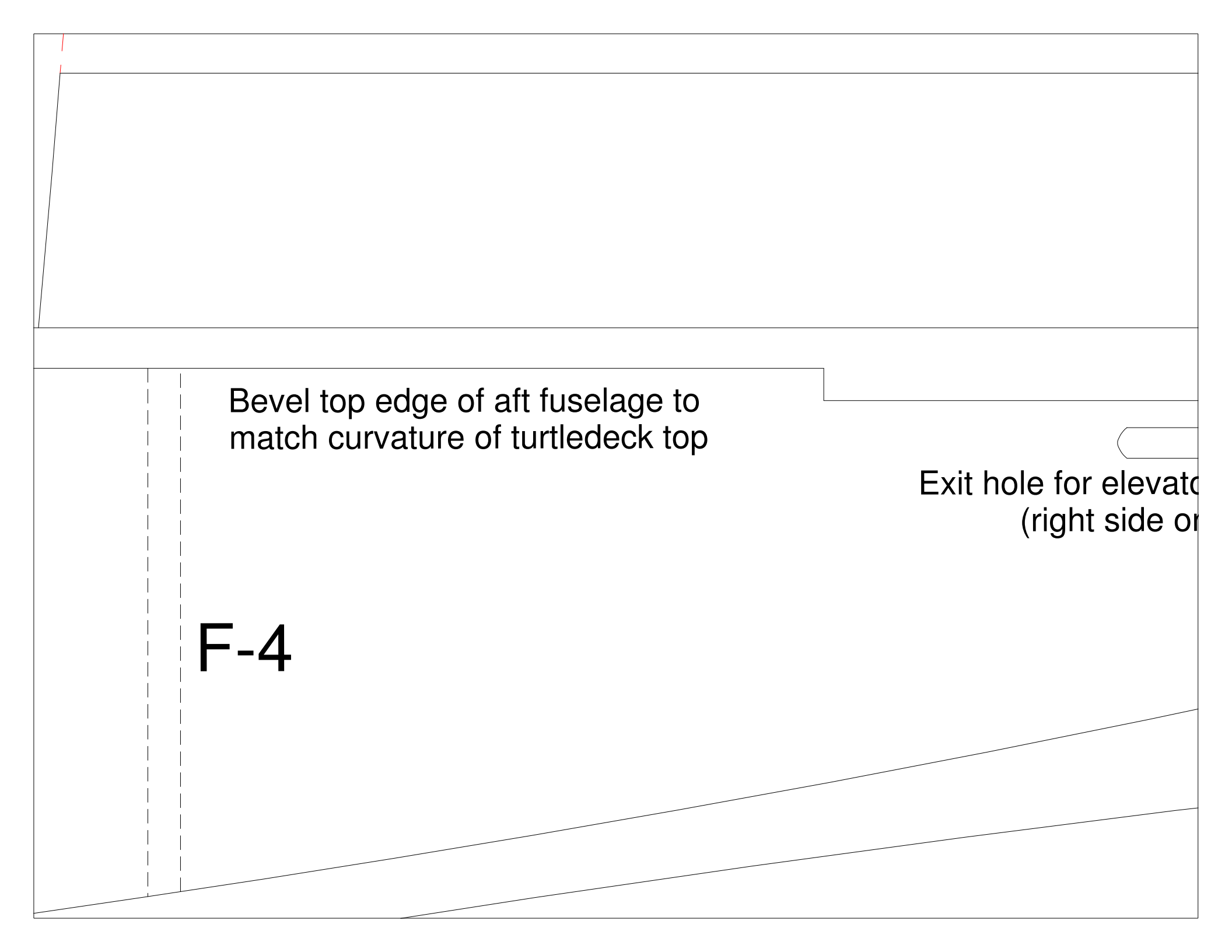

Bevel top edge of aft fuselage to  
match curvature of turtledeck top

The diagram shows a cross-section of an aircraft fuselage. At the top, there is a horizontal line representing the turtledeck top. Below it, the fuselage structure is shown with a beveled top edge on the right side. Two vertical dashed lines are drawn on the left side of the fuselage. On the right side, there is a rectangular cutout with a semi-circular end, representing an exit hole. The text 'Bevel top edge of aft fuselage to match curvature of turtledeck top' is positioned above the fuselage structure. The text 'Exit hole for elevator (right side of fuselage)' is positioned to the right of the cutout. The text 'F-4' is positioned below the fuselage structure on the left side.

Exit hole for elevator  
(right side of fuselage)

**F-4**

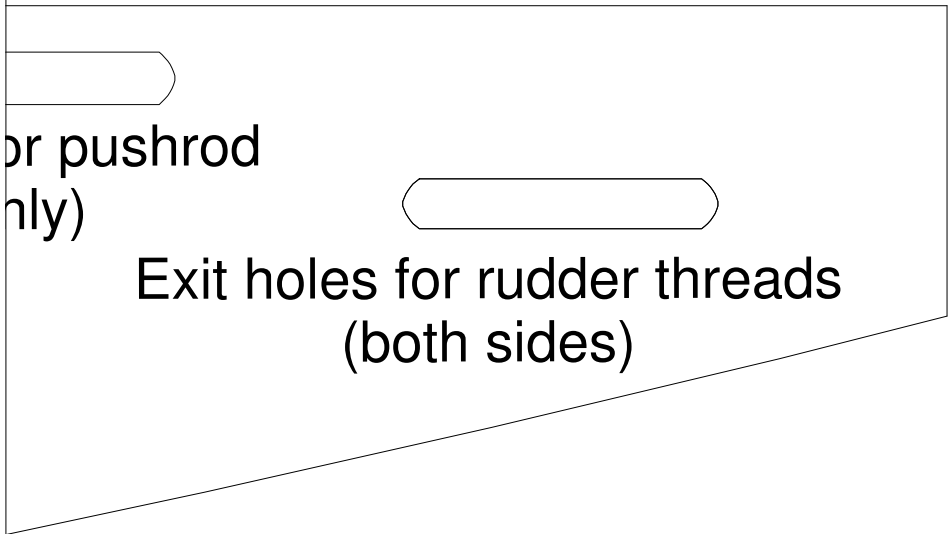

or pushrod  
(only)

Exit holes for rudder threads  
(both sides)

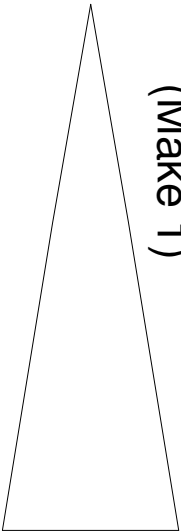

Tail skid support  
(Make 1)

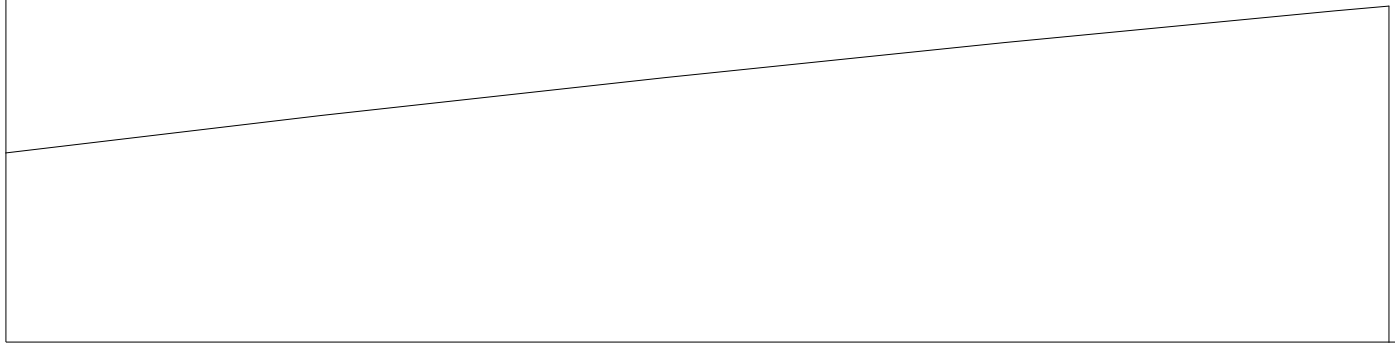

quare hardwood joiner  
degrees on leading edge)

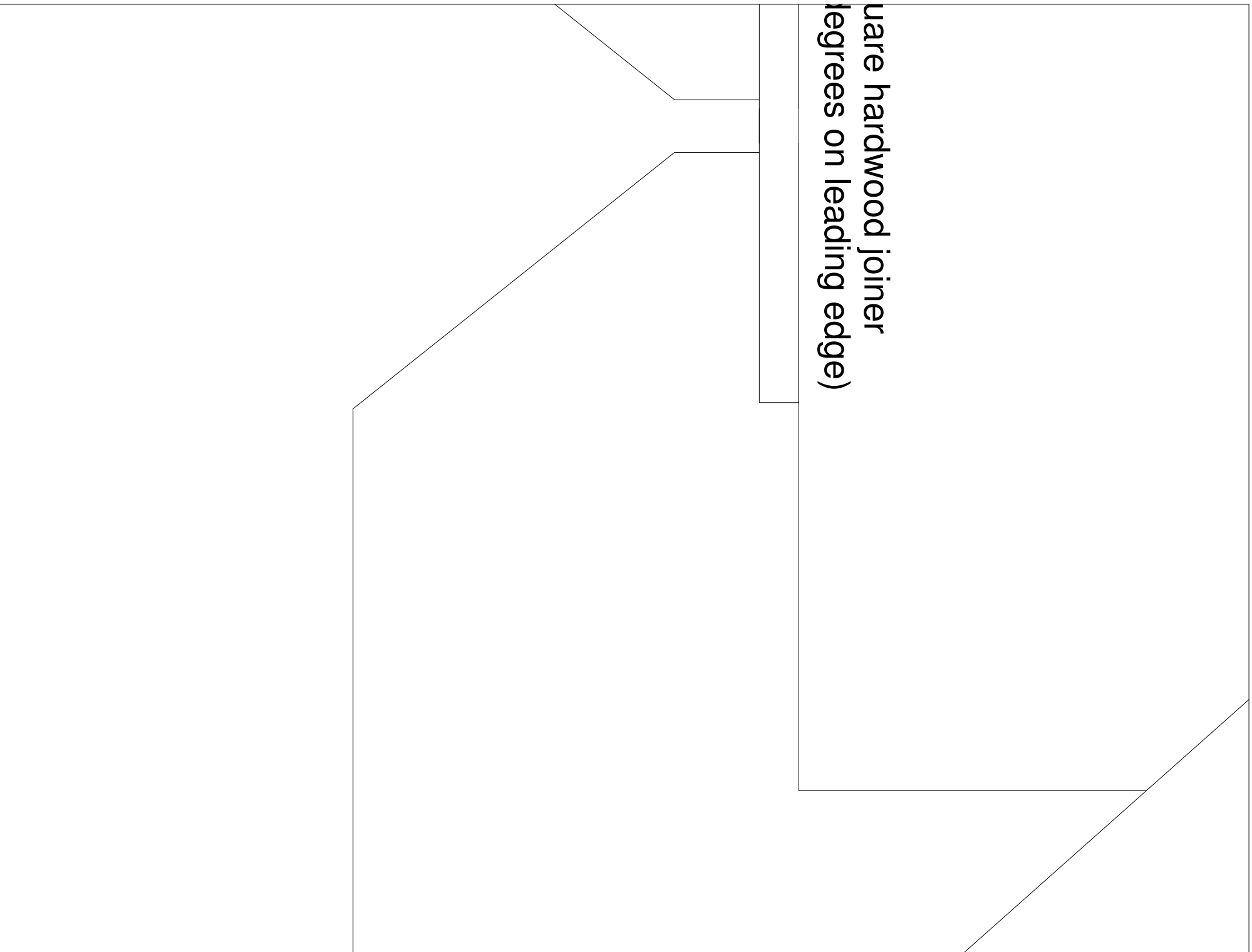

Vertical tail  
(Make 1)

Horizontal tail  
(Make 1)



Cut slot to  
fit wind struts

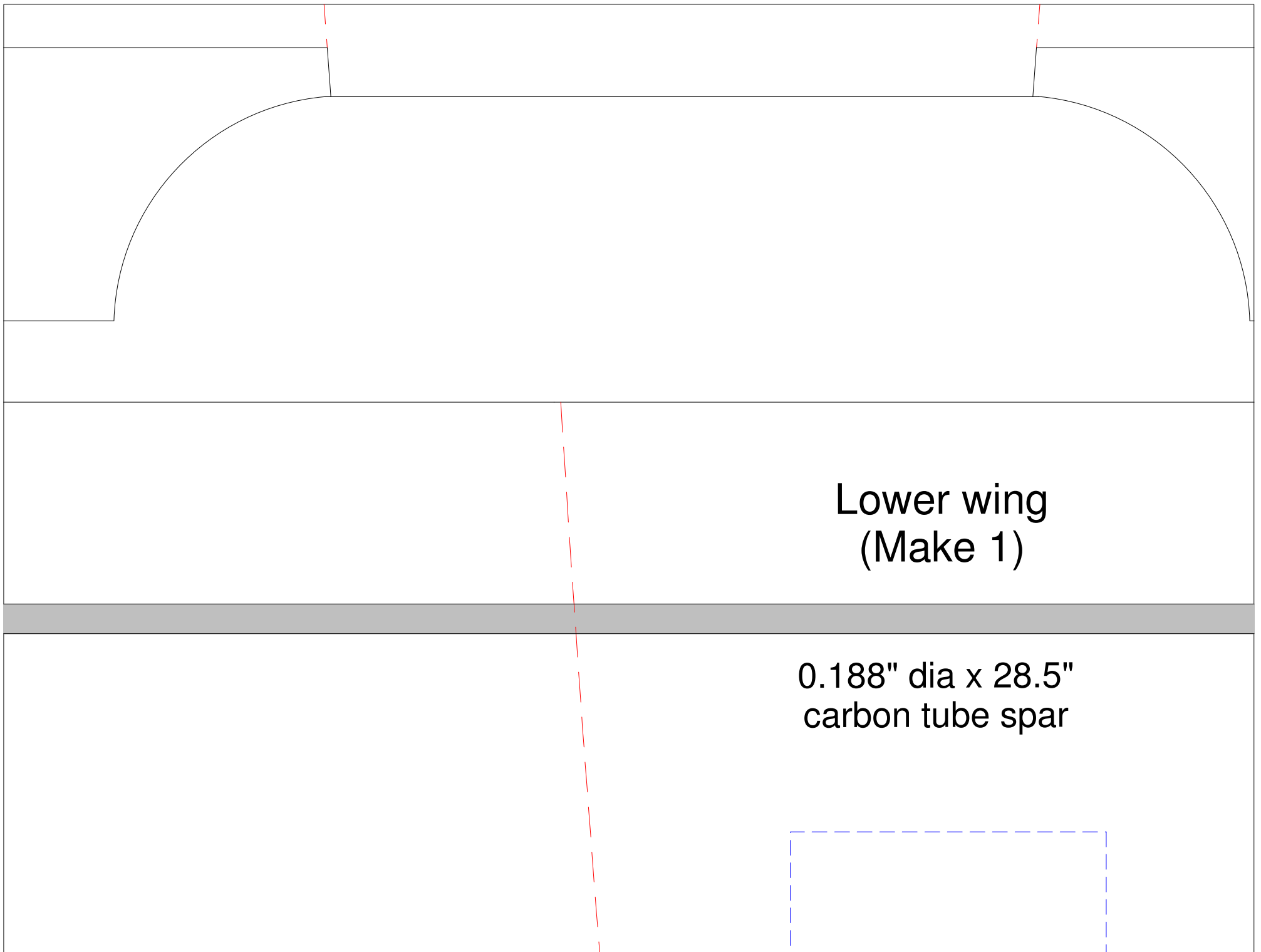

Lower wing  
(Make 1)

0.188" dia x 28.5"  
carbon tube spar

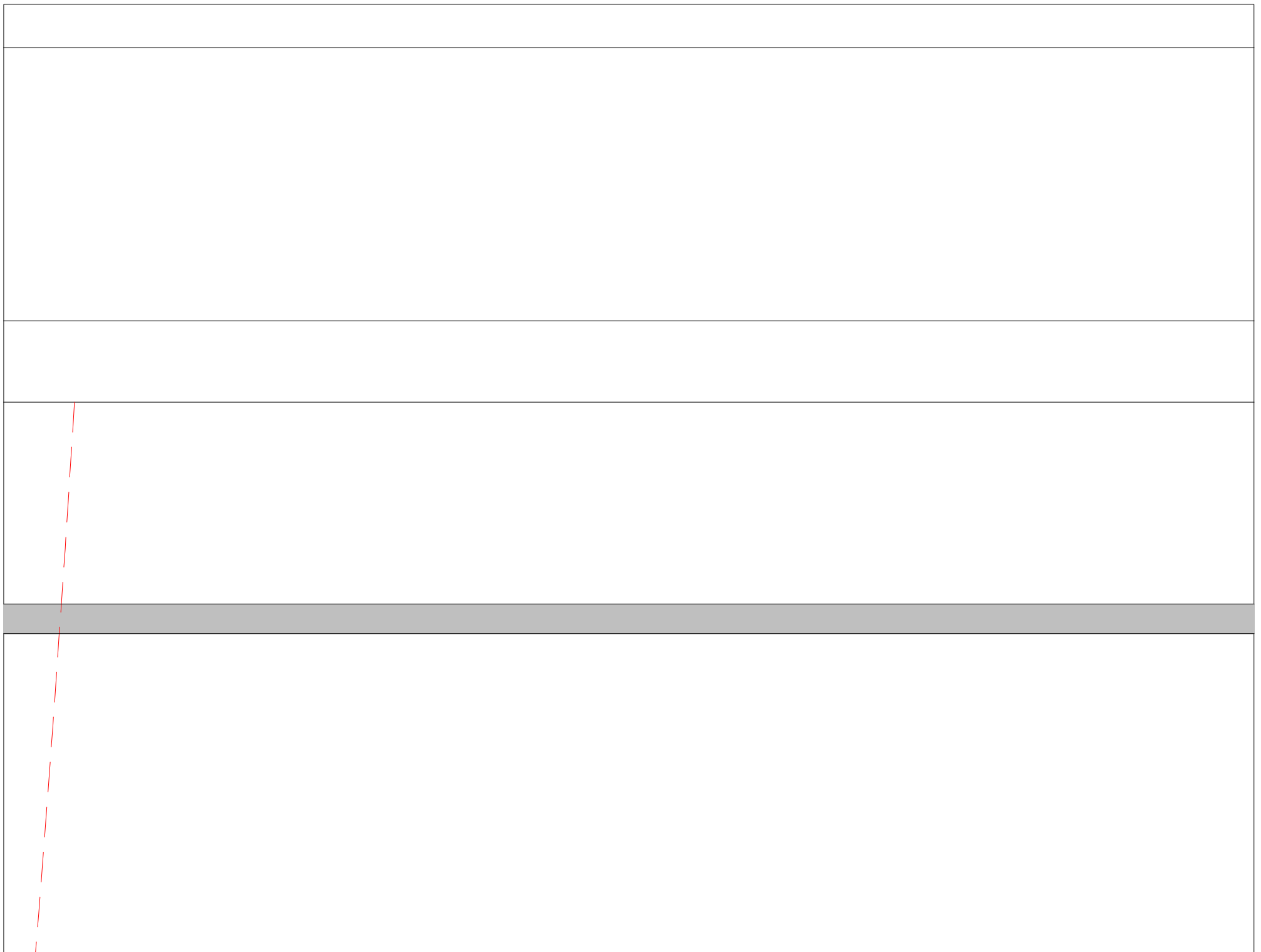

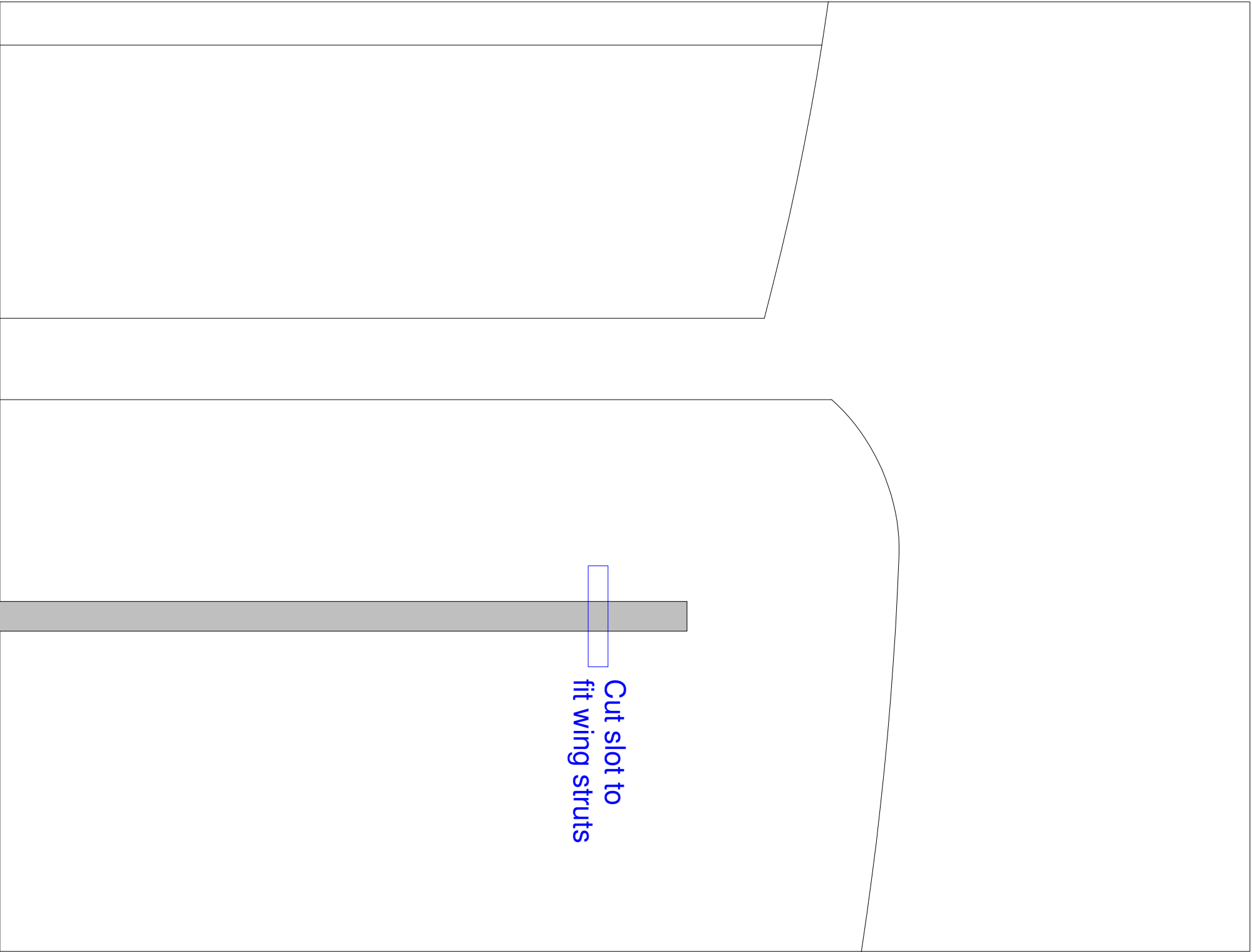

Cut slot to  
fit wing struts

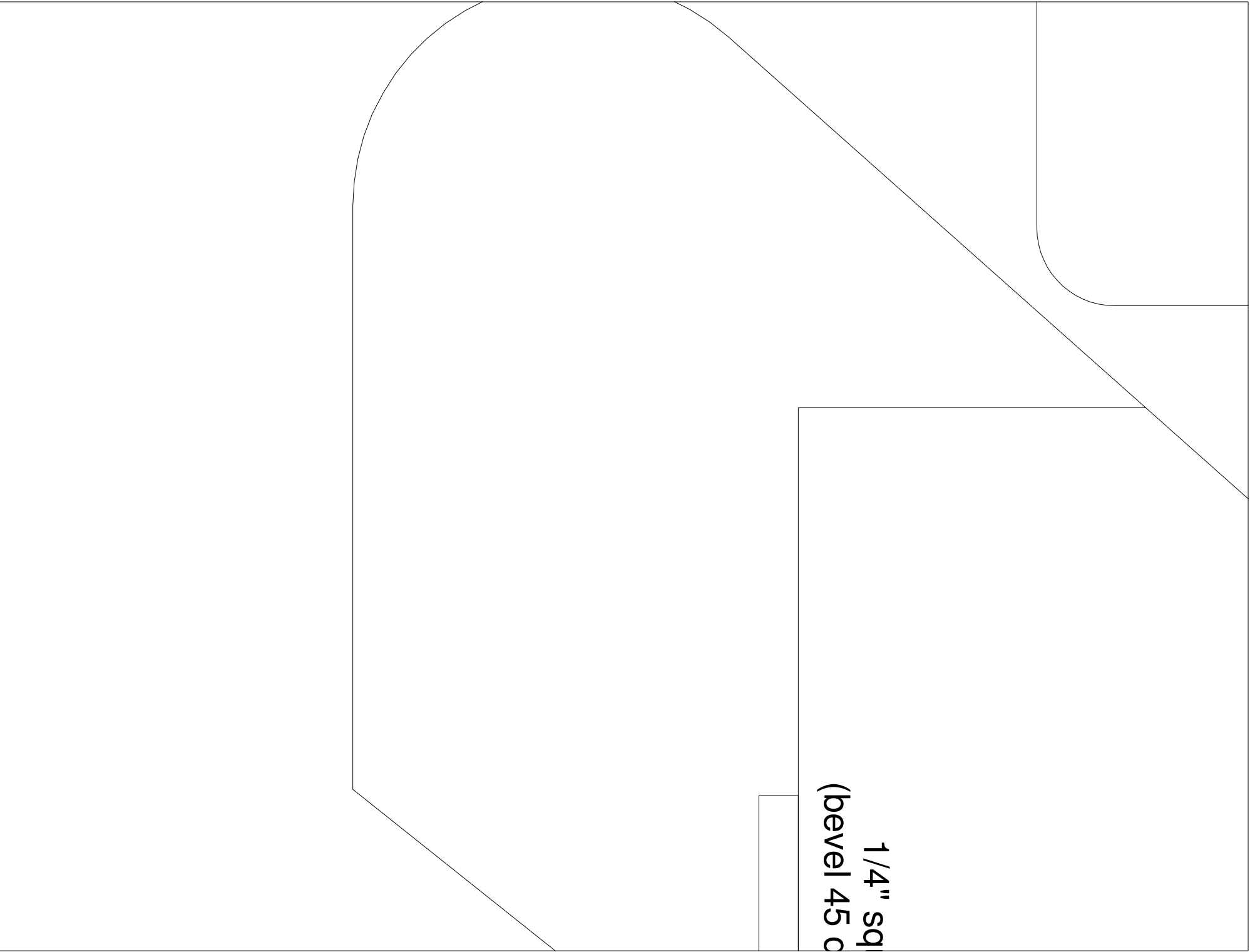

1/4" sq  
(bevel 45 c

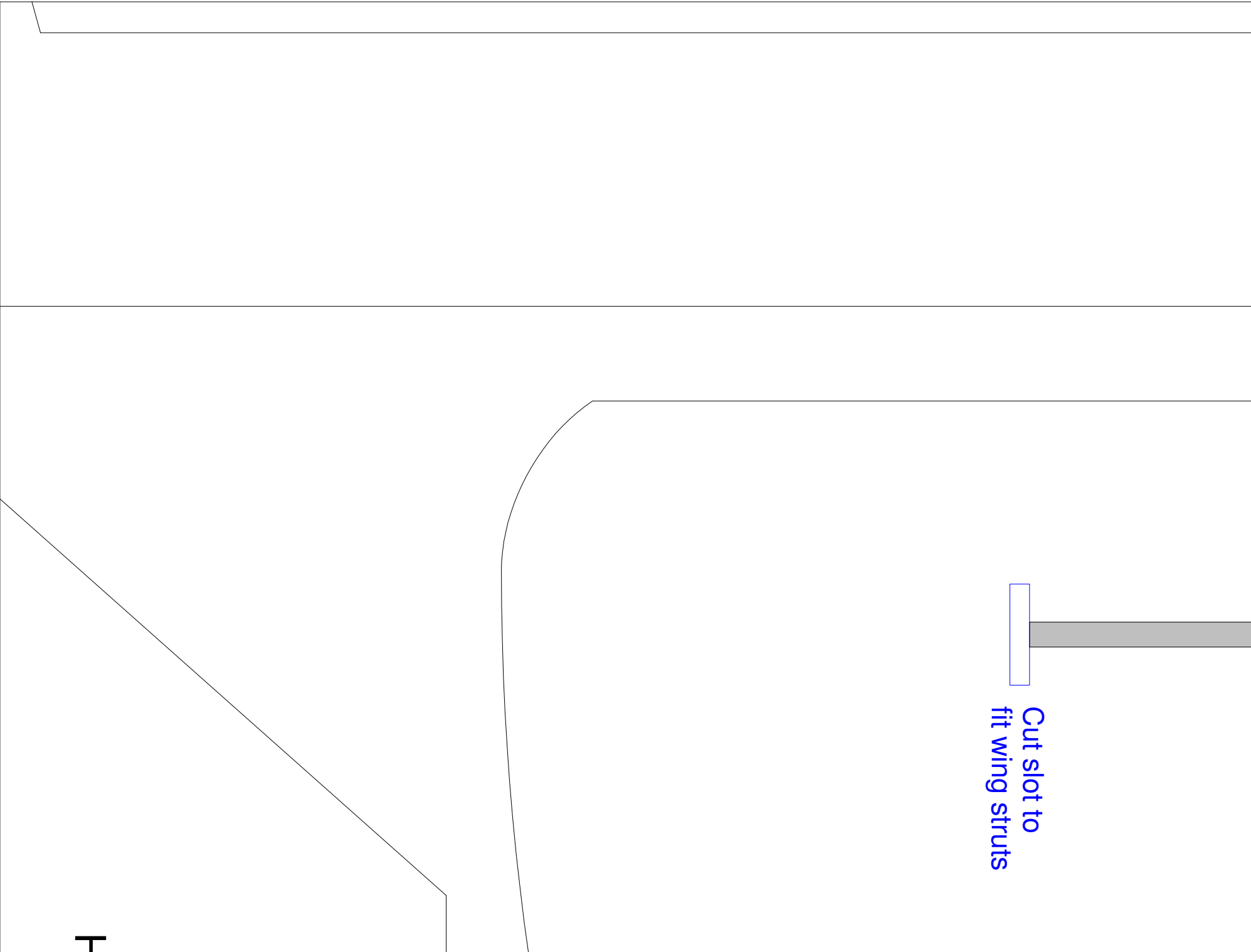

Cut slot to  
fit wing struts

T

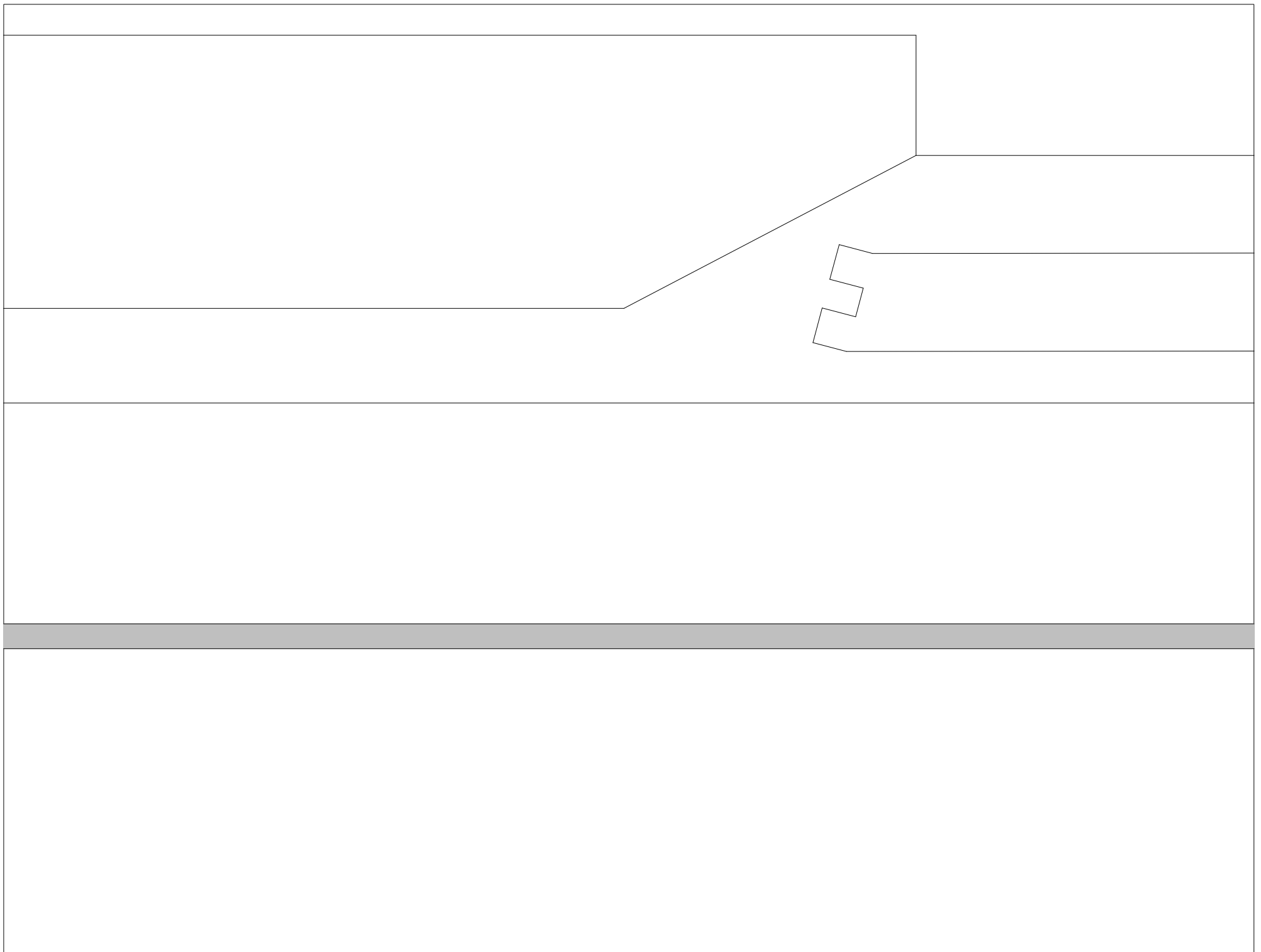

Main wing struts  
(Make 2 from 1/8" lite-ply)

Middle wing  
(Make 1)

1.3"



0.157" dia x 27.2"  
carbon tube spar

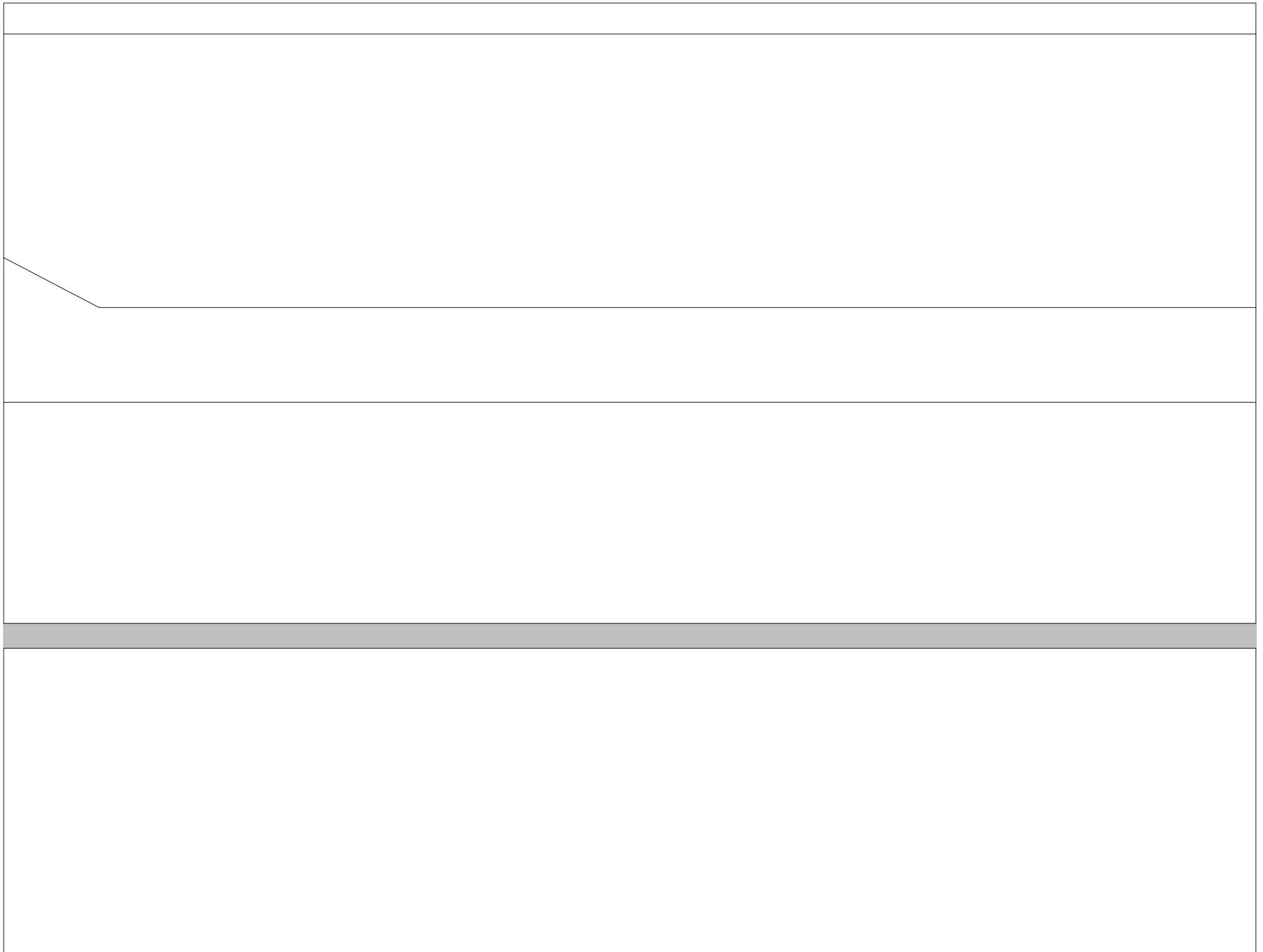

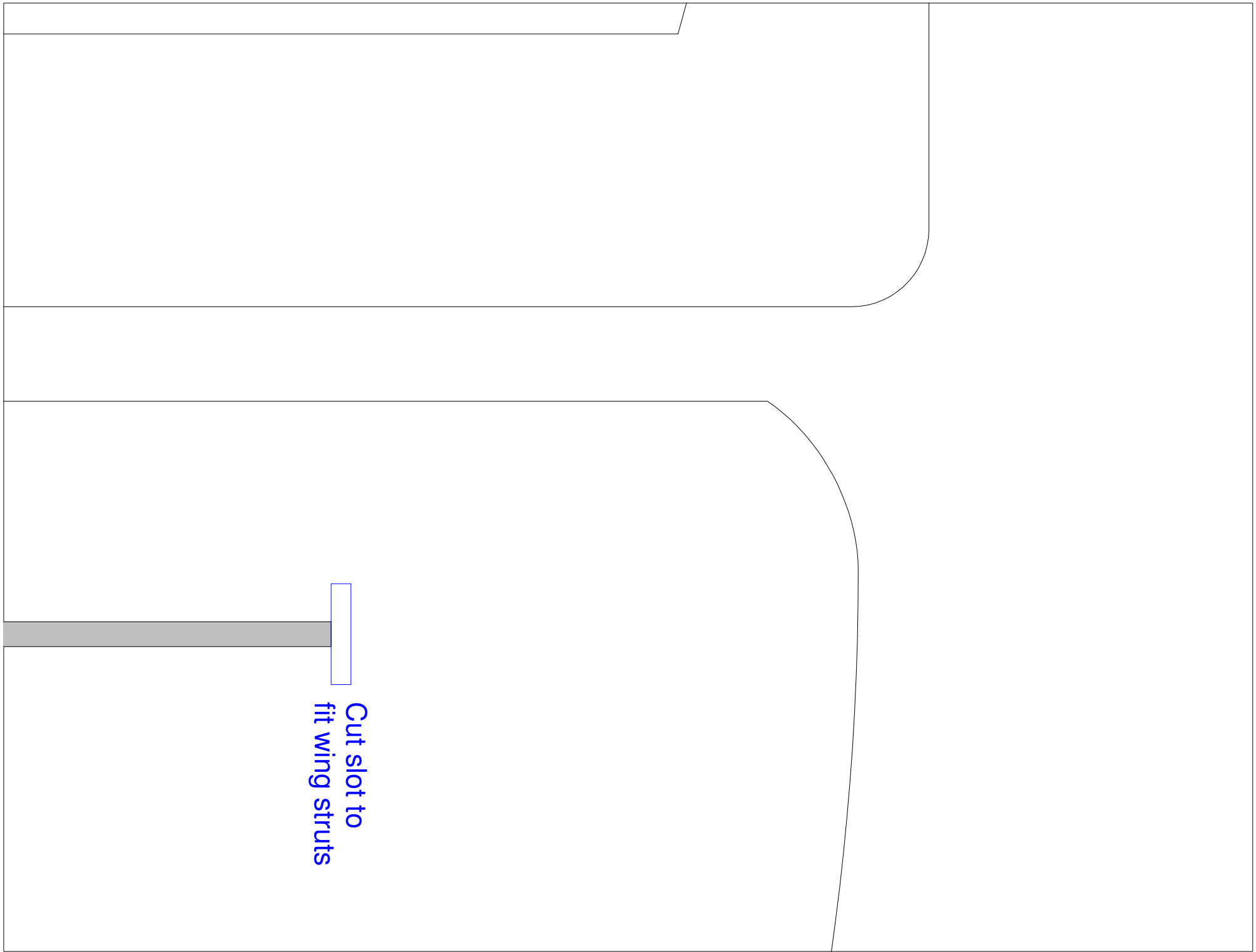

Cut slot to  
fit wing struts

# ***Fokker DR1 Parkflyer***

***Designed by Steve Shumate***  
***Copyright © 2005 All Rights Reserved***

**All parts are made from 6 mm Depron or  
BlueCore foam unless otherwise specified**

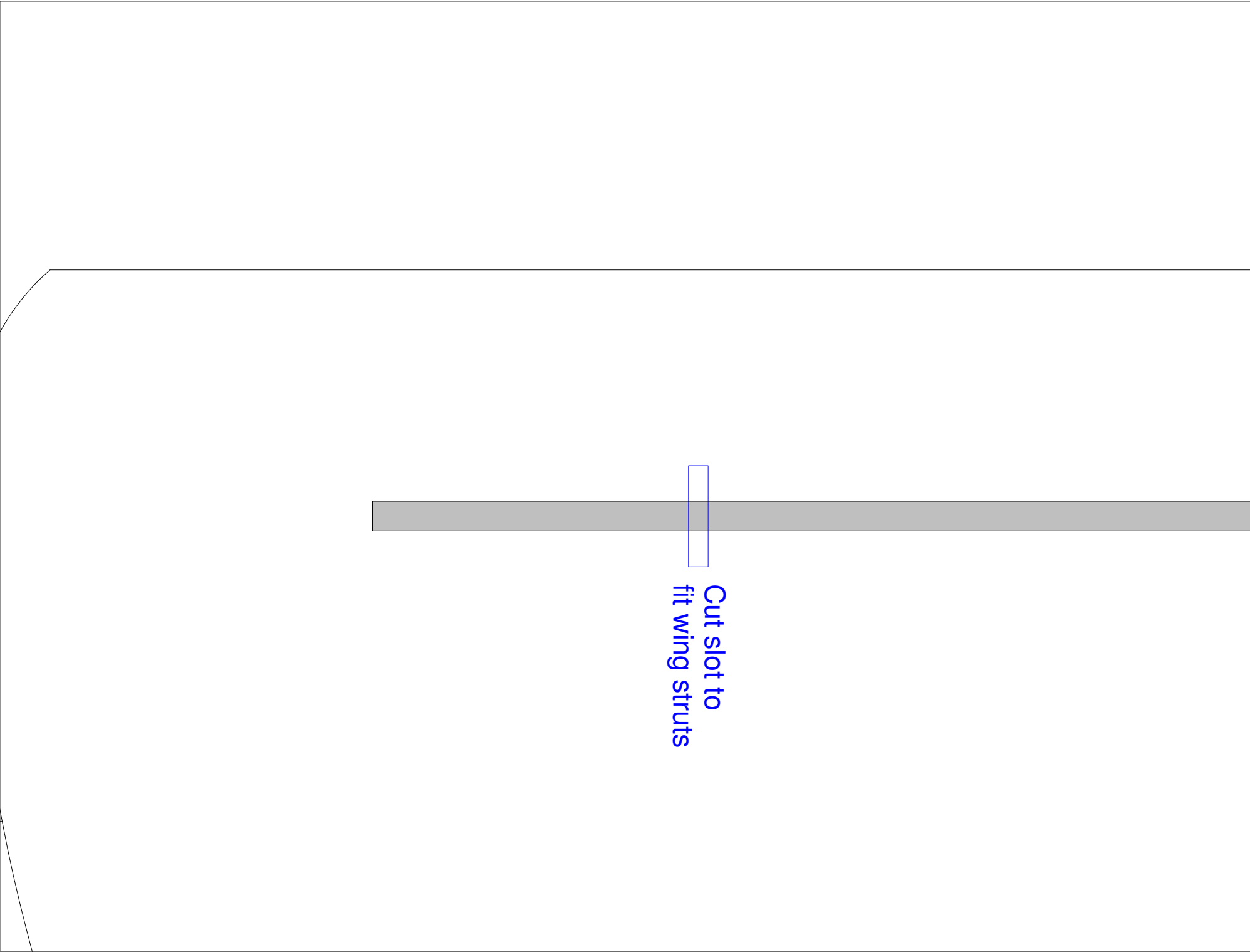

Cut slot to  
fit wing struts

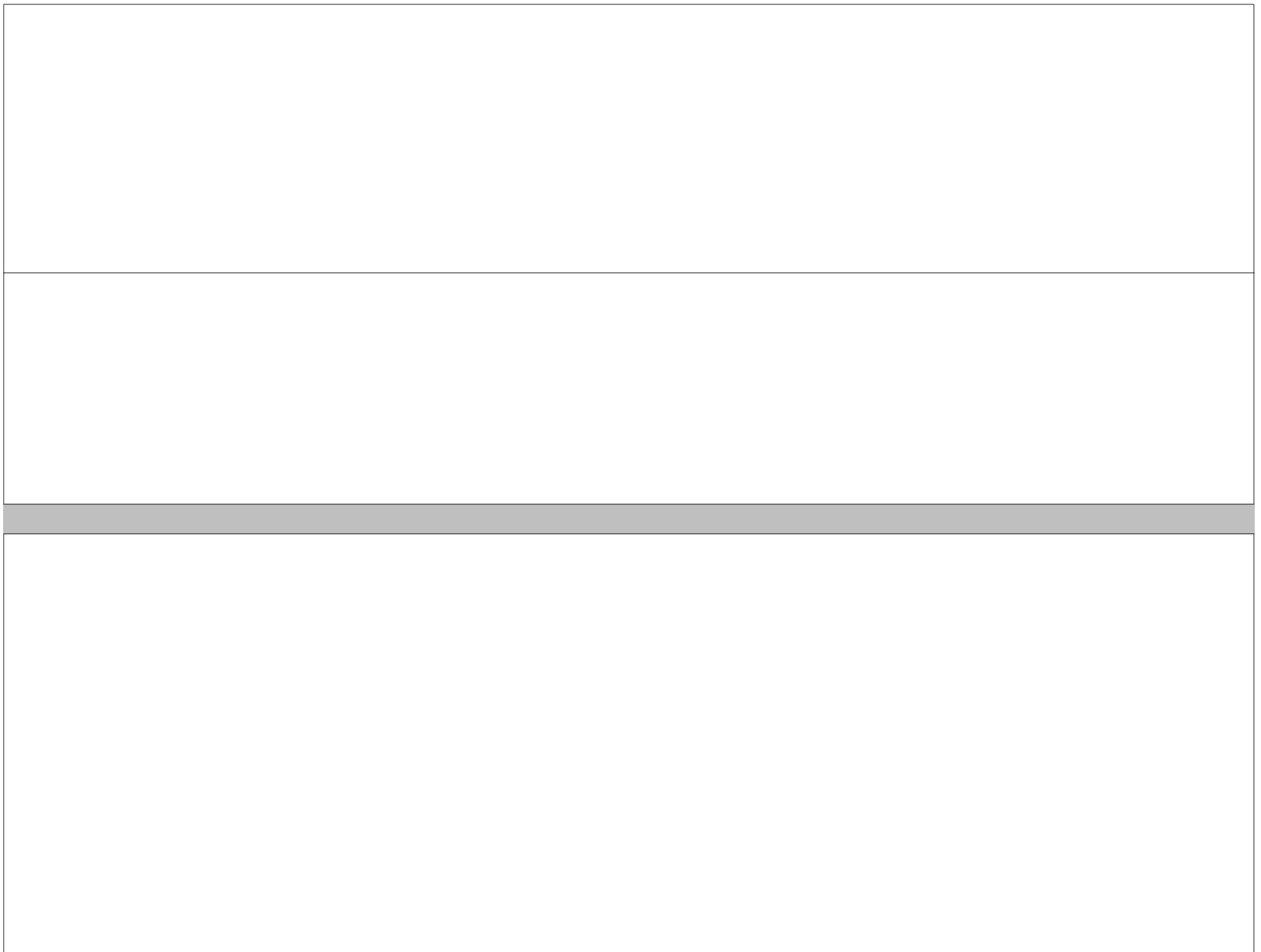

Upper wing  
(Make 1)

0.188" dia x 31.5"  
carbon tube spar



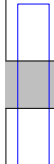
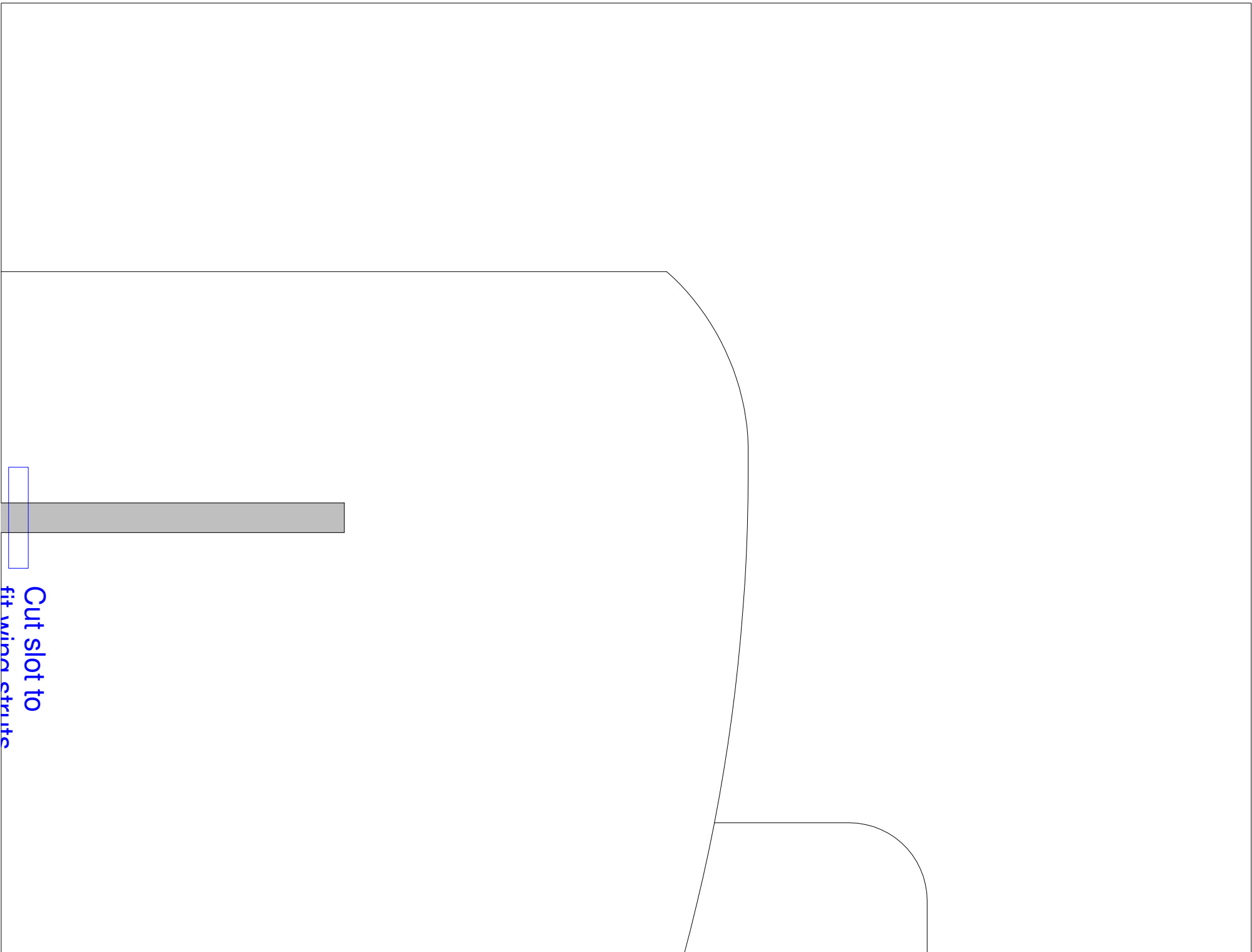

Cut slot to  
fit window struts

gear strut angle guage  
(Make 1)



Center wing strut ang  
(Make 2)



Cut slot for 0.125" dia x 8  
carbon tube axle

Landing gear wing  
(Make 2, laminate,  
and sand to airfoil sha

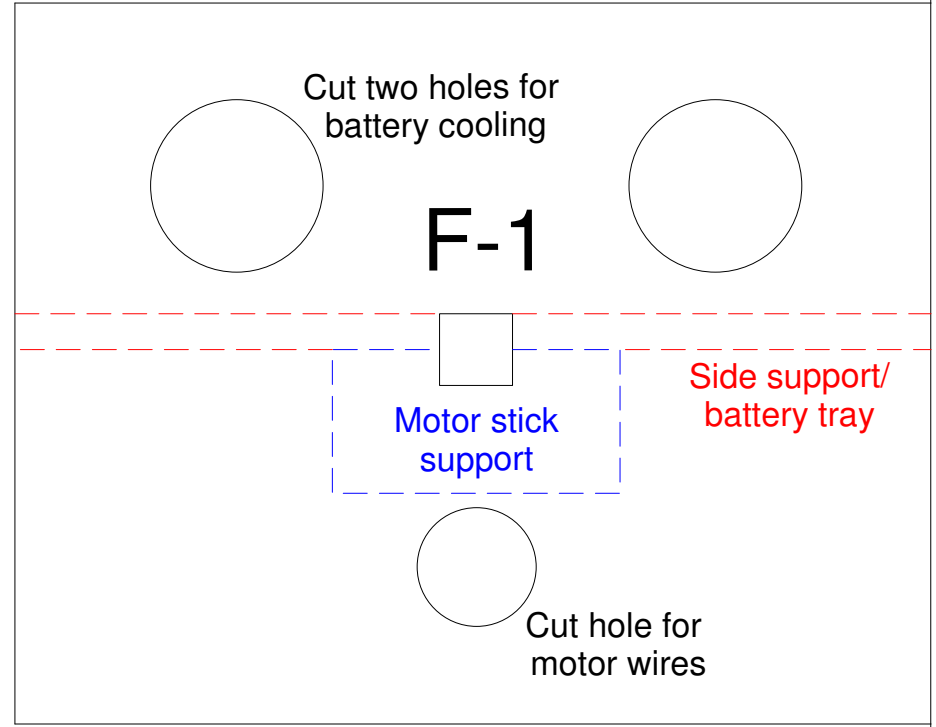

Cut two holes for  
battery cooling and  
wiring access

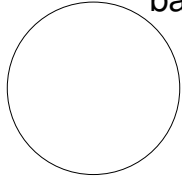

**F-2**

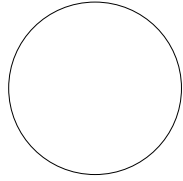

Motor stick  
support



Side support/  
battery tray

**F-3**

Motor stick side supports/  
battery tray  
(Make 2)

**F-4**

Hole for elevator push



Slot for rudder threads



Cut  
lightening  
hole

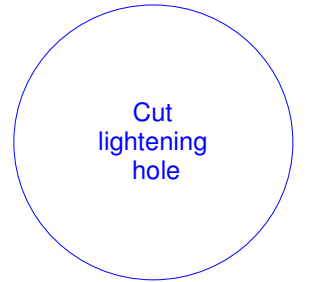

hrod

Fwd wing strut doubler  
(Make 2)

Aft landing gear/  
aft wing strut doubler  
(Make 4)

Fwd landing gear  
strut doubler  
(Make 2)

Wheels used on  
prototype (for 3.0" O.D.  
O-rings) (Make 2)

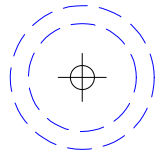

2.75" dia.

Wheel hubs  
(Make 2 each  
from 1/32" ply)

Inboard

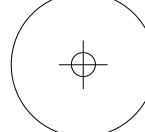

3/4" dia.

Outboard

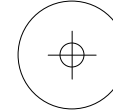

9/16" dia.

Drill all wheel hubs for  
1/8" dia. carbon tube axle

Wheel axle stop  
(Make 2 from  
1/8" lite-ply)

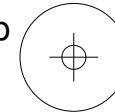

9/16" dia.

Optional scale wheels  
(for 3.5" O.D. O-rings)  
(Make 2)

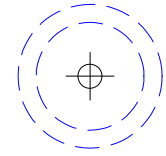

3.25" dia.



Fwd fuselage bottom  
(Make 1)

Aileron control horns  
(Make 2 from 1/32" ply)

Aileron connectors  
(Make 6 from 1/32" ply)

Base cross piece for  
all alignment gauges  
(Make 2)

Upper wing alignment gauge  
(Make 2)

Lower wing alignment gauge

Landing gear

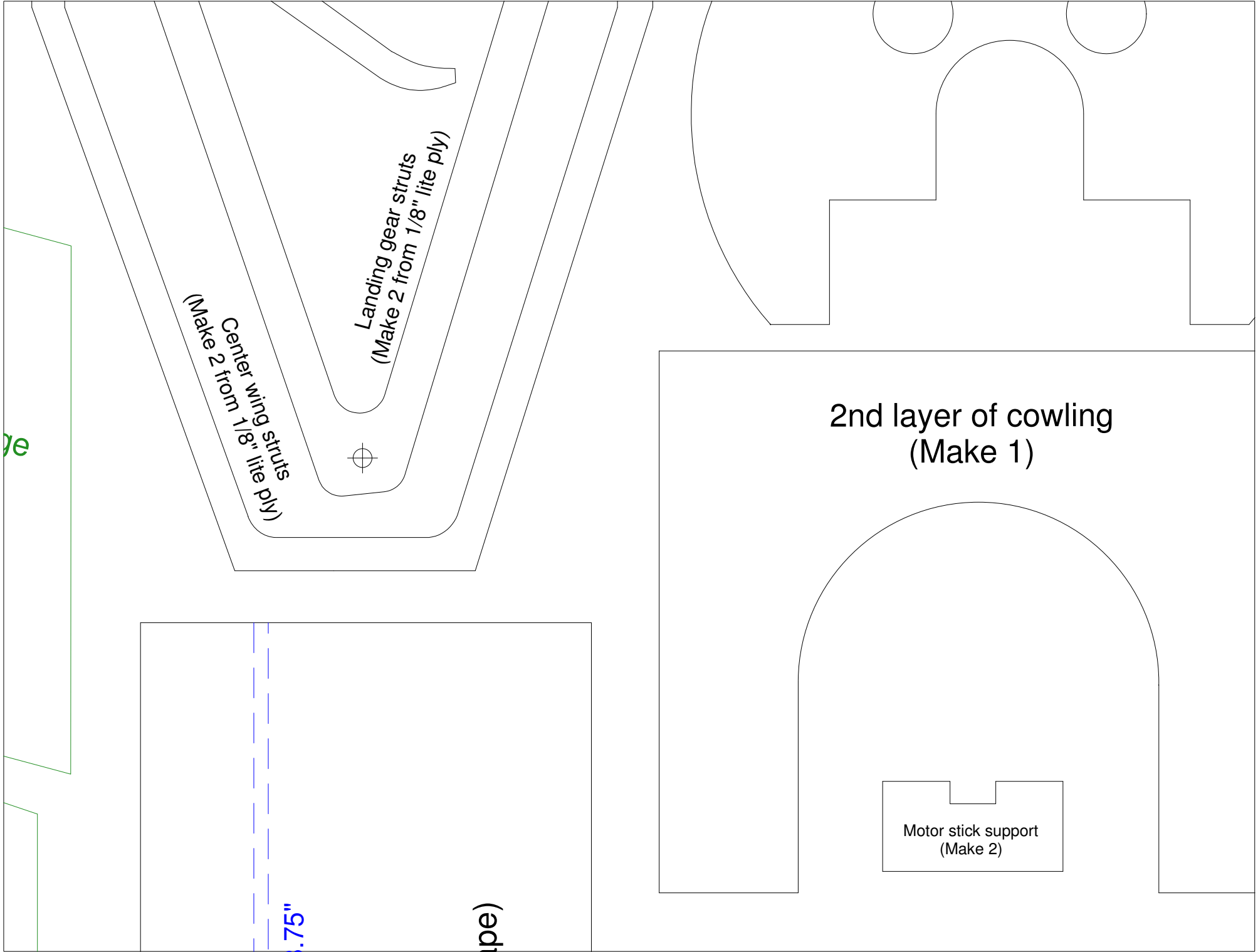

Center wing struts  
(Make 2 from 1/8" lite ply)

Landing gear struts  
(Make 2 from 1/8" lite ply)



.75"

ype)

2nd layer of cowling  
(Make 1)

Motor stick support  
(Make 2)

ge

F-1

F-2

Servo tray location

Fwd landing gear  
strut doubler

Aft landing gear  
strut doubler

Wing align

Inner layers of cowling  
(Make 7)

GWS Pico  
servos  
shown

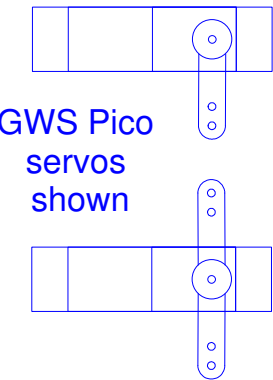

Servo tray  
(Make 2 and  
laminated)

Top overwing fairing  
(Make 1)

Sand sides to rounded shape to  
match upper fuselage curvature

Fuselage sides  
(Make 2)

F-4

ment marks



Fwd fuse top  
(Make 2 and laminate)

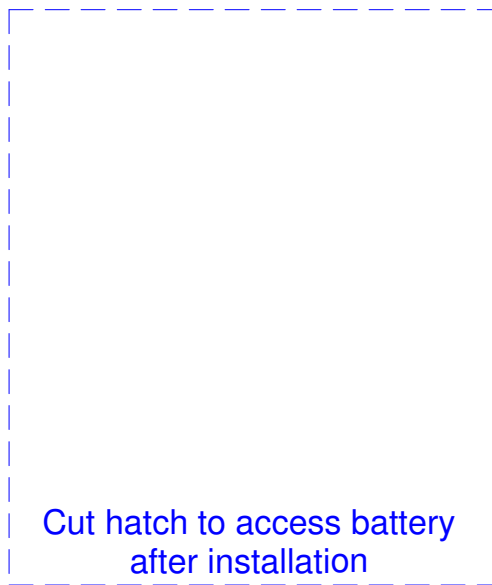

Cut cockpit hole  
AFTER installing  
turtledeck top

Turtledeck  
(Make 1 from 3m

Aft fuselage bottom  
(Make 1 from 3mm Depron)

Top  
(Make 1 from 3mm Depron)

Turtledeck/  
stabilizer  
trim piece  
(Make 1 from  
3mm Depron)

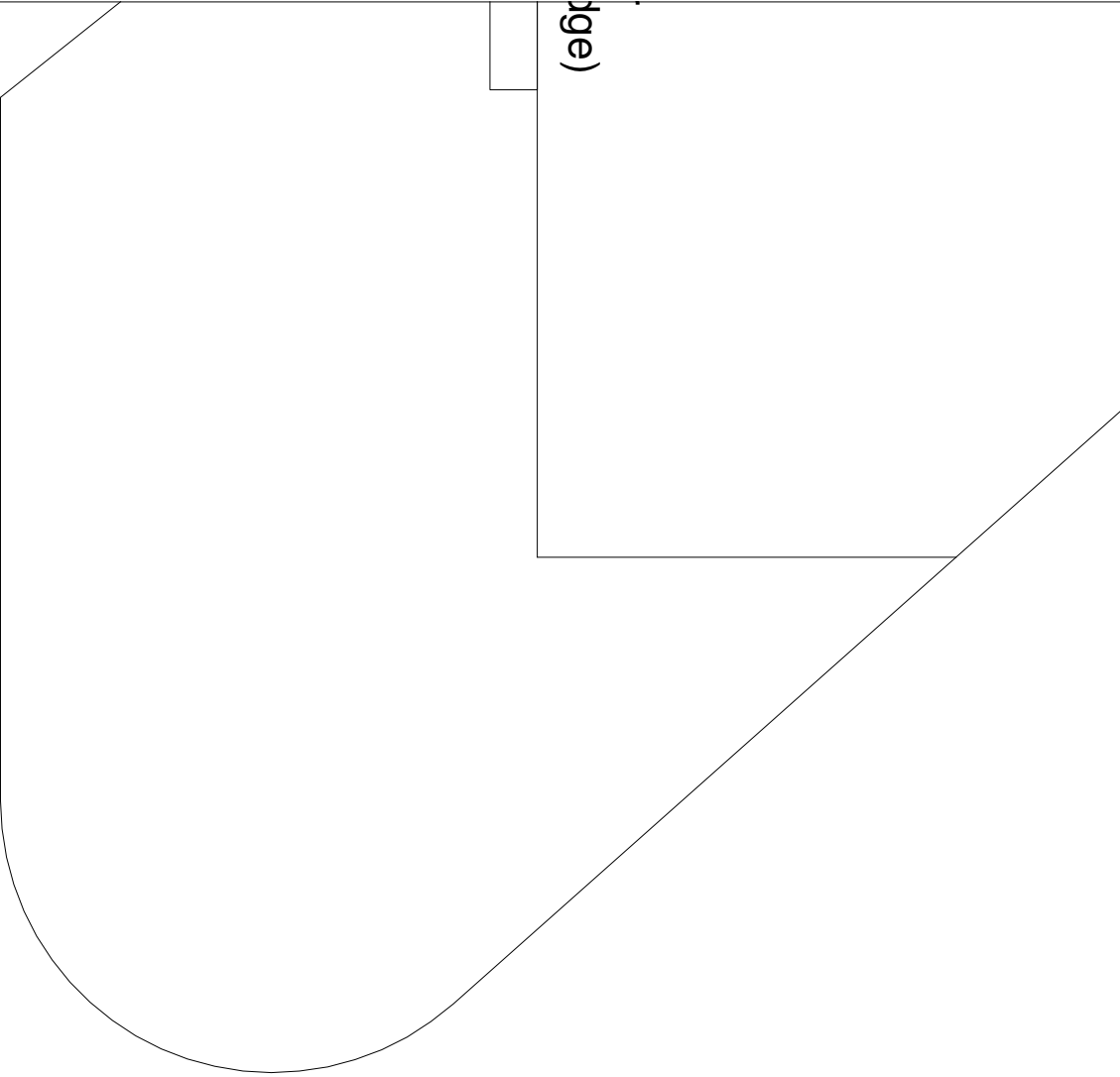

(edge)

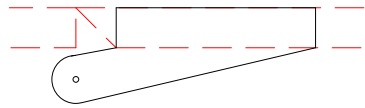

Elevator control horns  
(Make 1 from 1/32" ply)

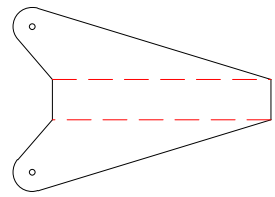
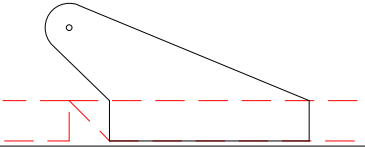

Rudder control horn  
(for pull-pull threads)  
(Make 1 from 1/32" ply)

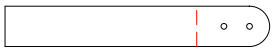

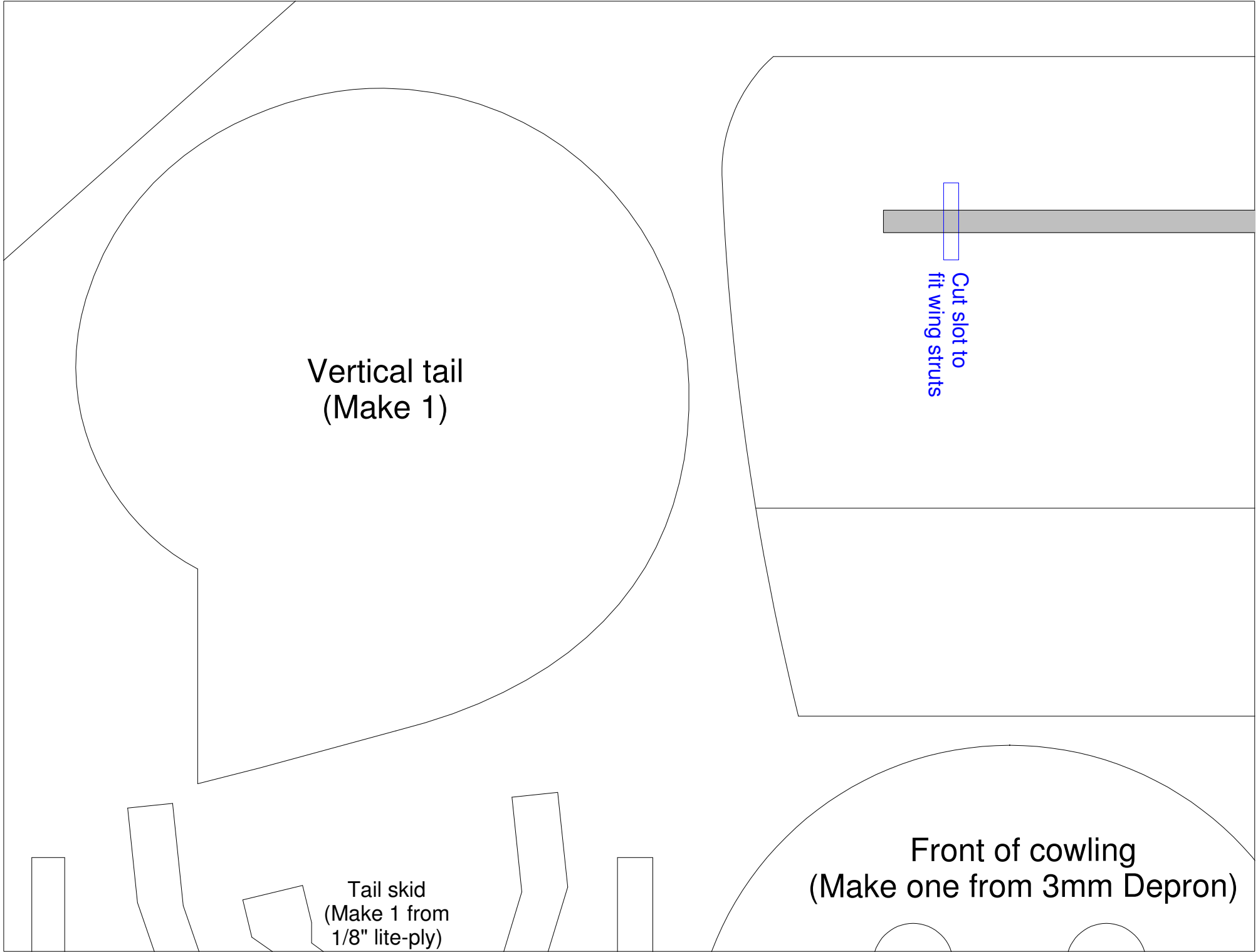

Vertical tail  
(Make 1)

Cut slot to  
fit wing struts

Front of cowling  
(Make one from 3mm Depron)

Tail skid  
(Make 1 from  
1/8" lite-ply)



Fwd wing strut doubler

Aft wing strut doubler

0.  
ca

Lower wing  
(Make 1)

188" dia x 28.5"  
carbon tube spar

Cut access hatch  
for receiver

Bevel top edge of aft fuselage to  
match curvature of turtledeck top

Exit hole for elevator  
(right side)

F-3

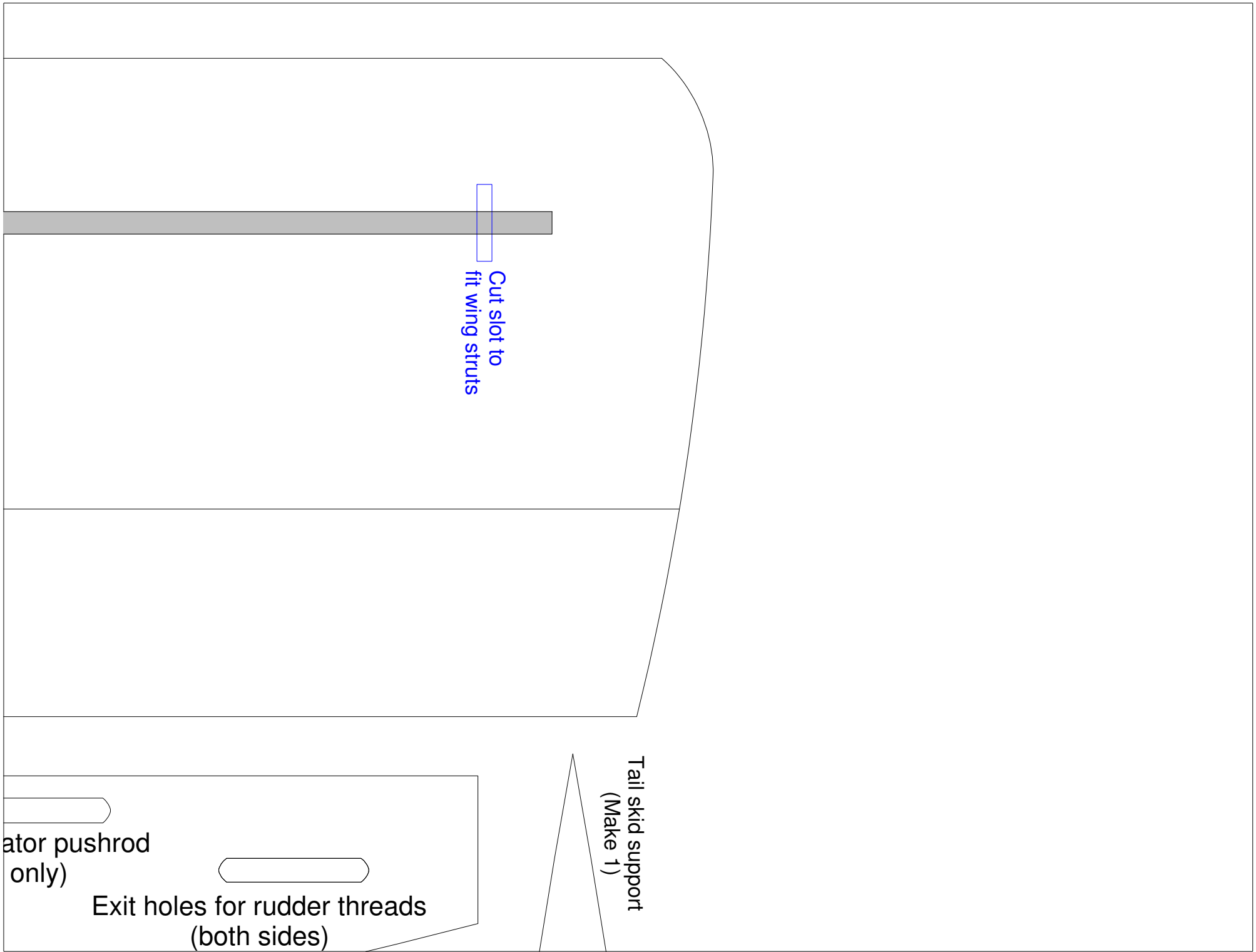

Cut slot to  
fit wing struts

Tail skid support  
(Make 1)

governor pushrod  
(only)

Exit holes for rudder threads  
(both sides)

1/4" square hardwood joiner  
(bevel 45 degrees on leading edge)

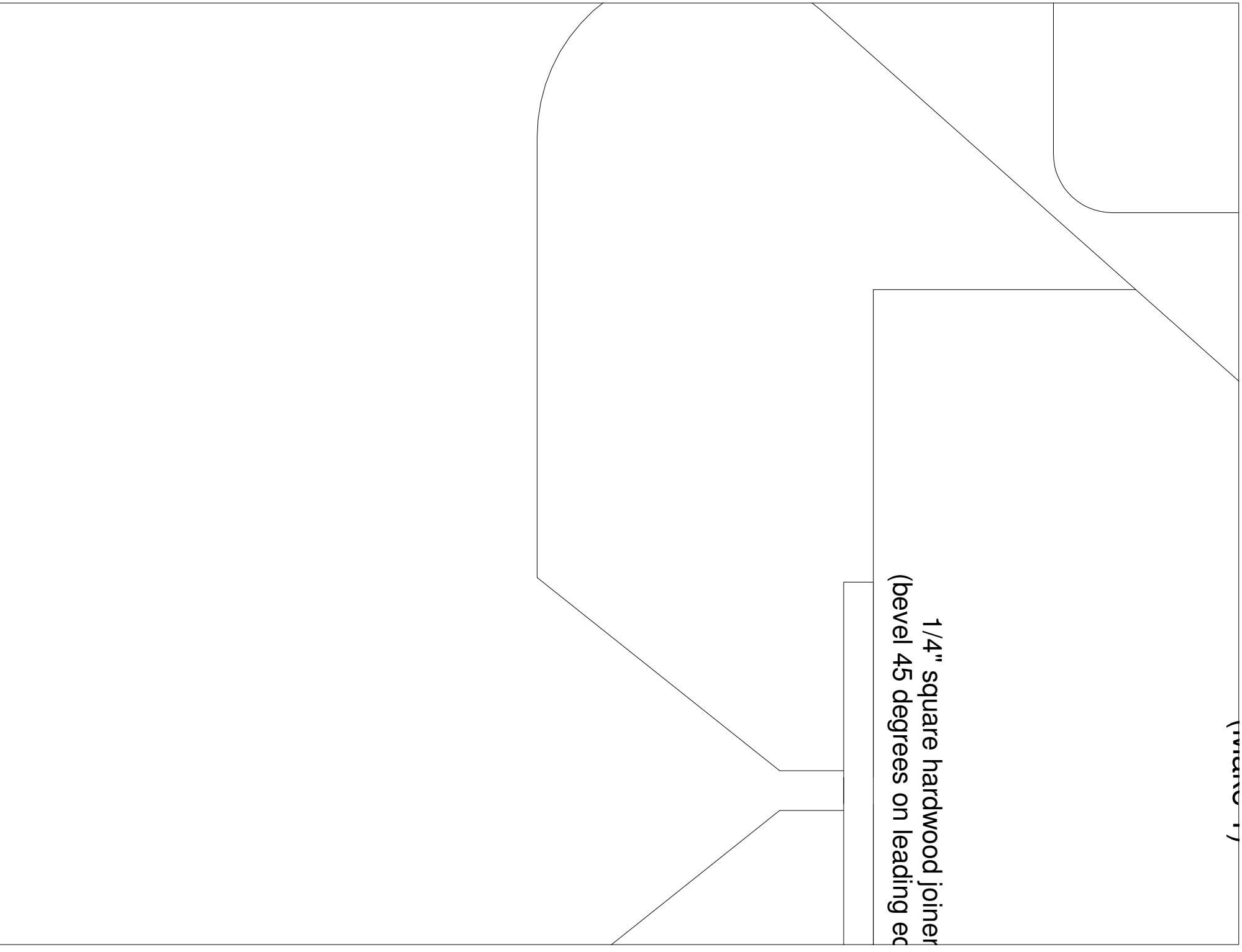

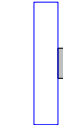
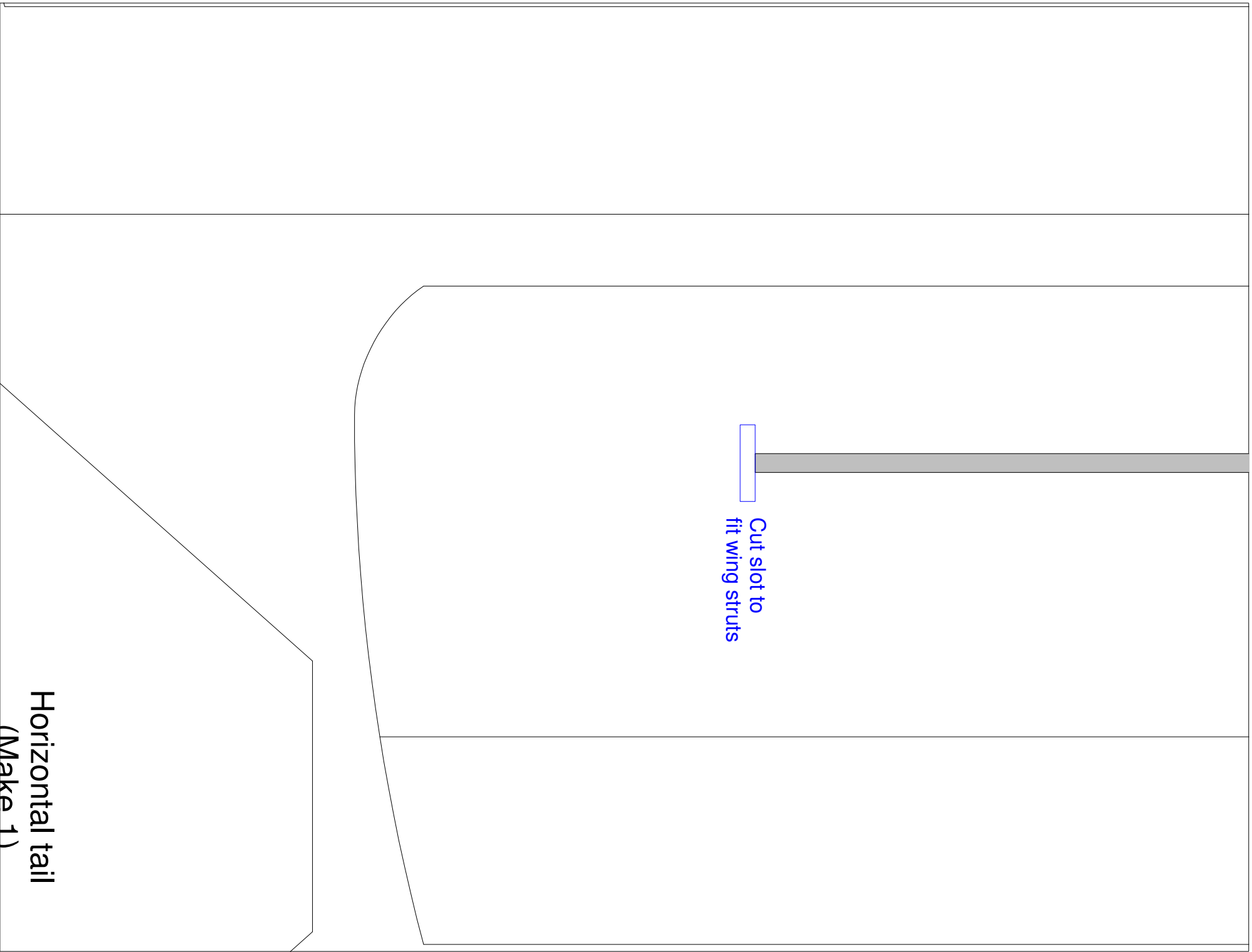

Cut slot to  
fit wing struts

Horizontal tail  
(Make 1)

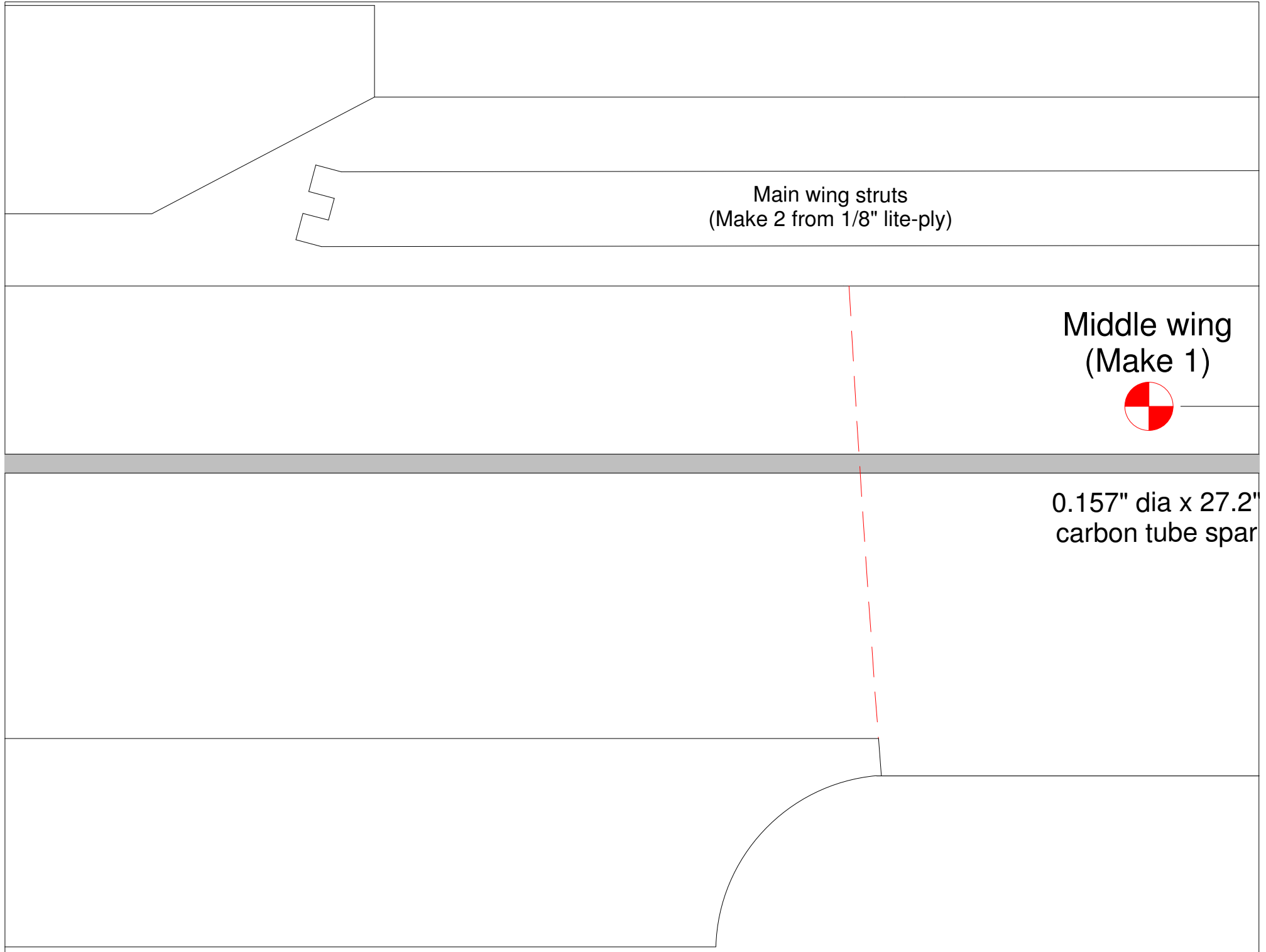

Main wing struts  
(Make 2 from 1/8" lite-ply)

Middle wing  
(Make 1)



0.157" dia x 27.2"  
carbon tube spar

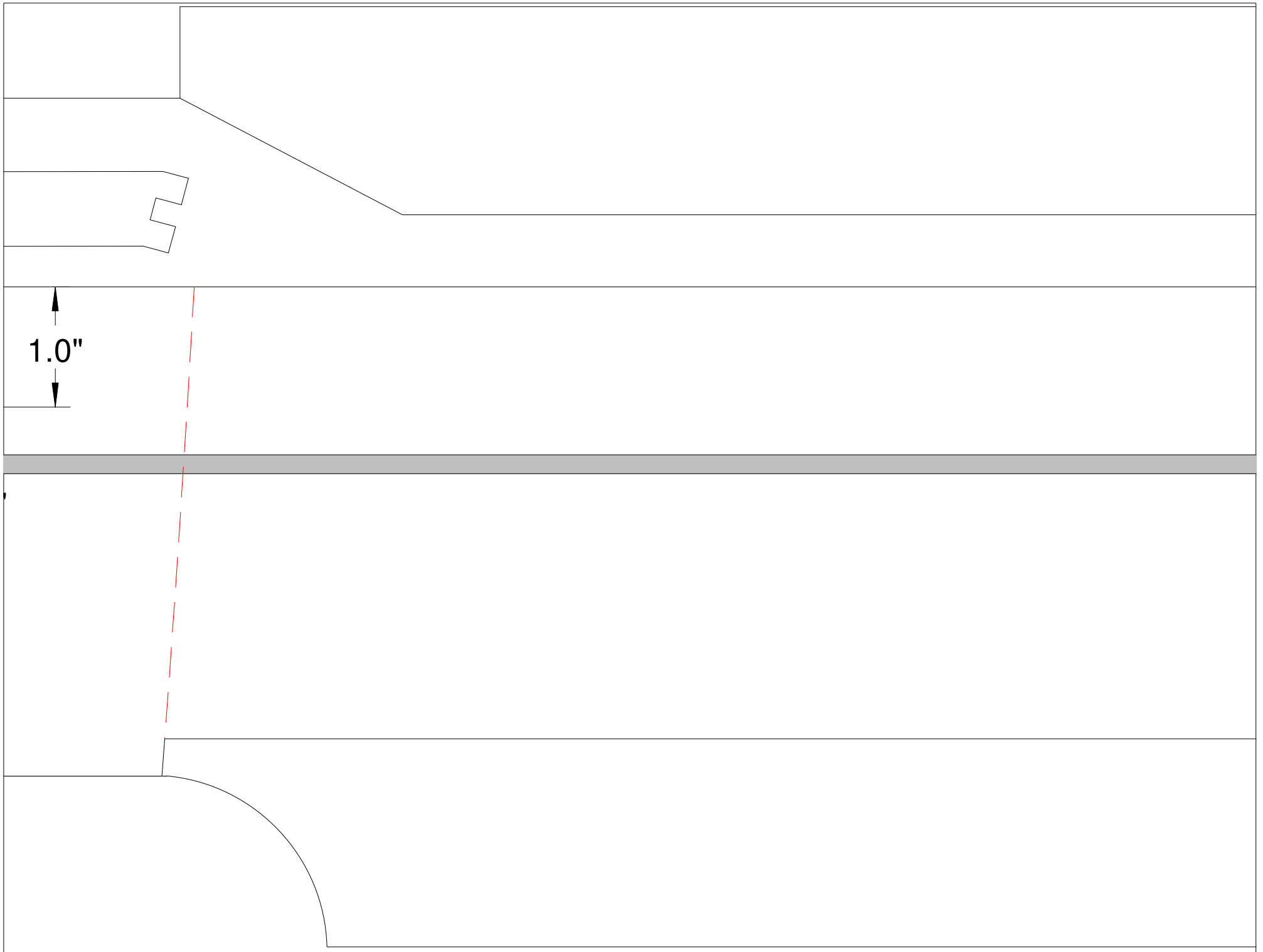



Cut slot to  
fit wing struts

# ***Fokker DR1 Parkflyer***

***Designed by Steve Shumate***

***Copyright © 2005 All Rights Reserved***

**All parts are made from 6 mm Depron or  
BlueCore foam unless otherwise specified**



Cut slot to  
fit wing struts

Upper wing  
(Make 1)

0.188" dia x 31.5"  
carbon tube spar

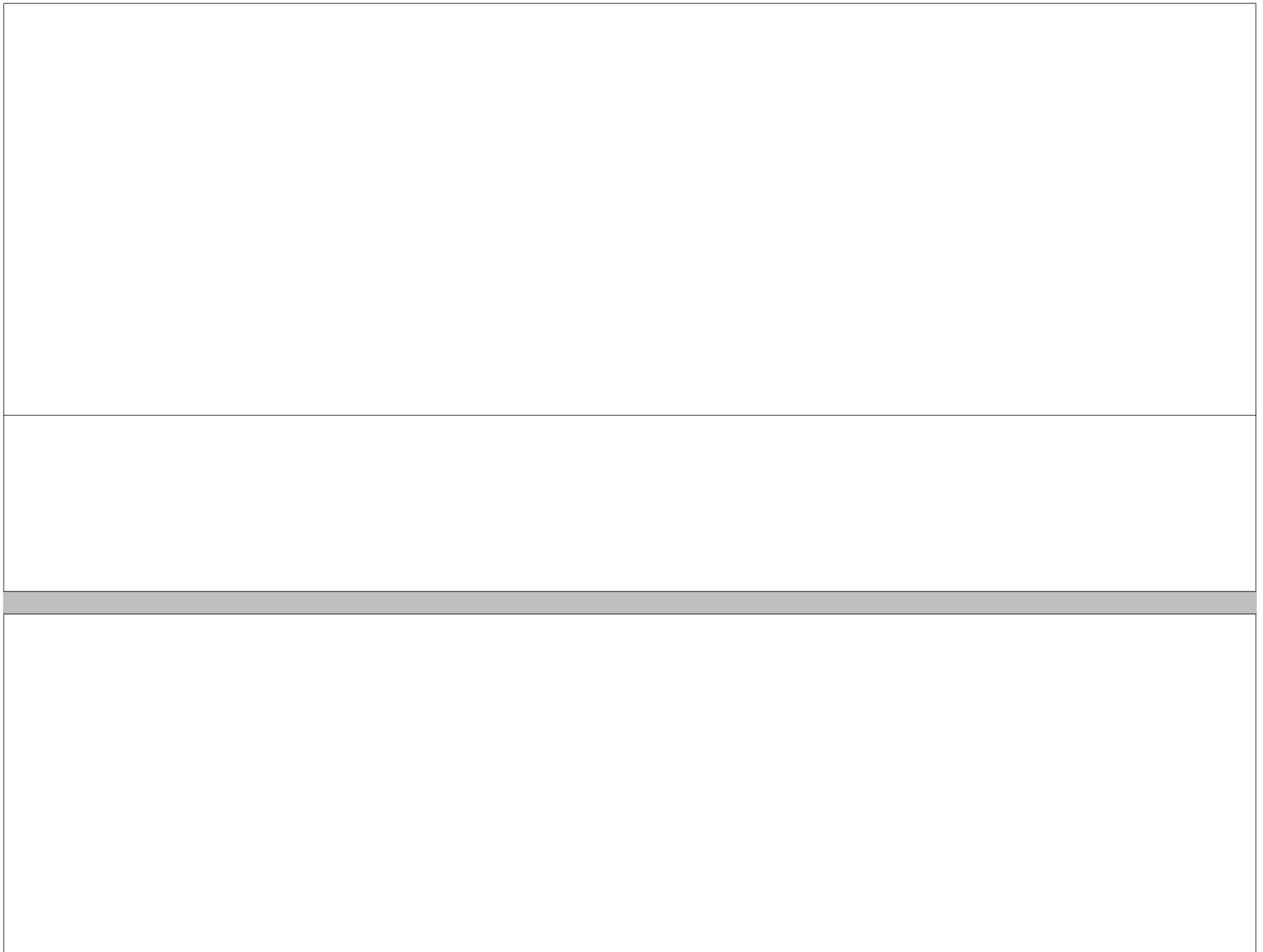

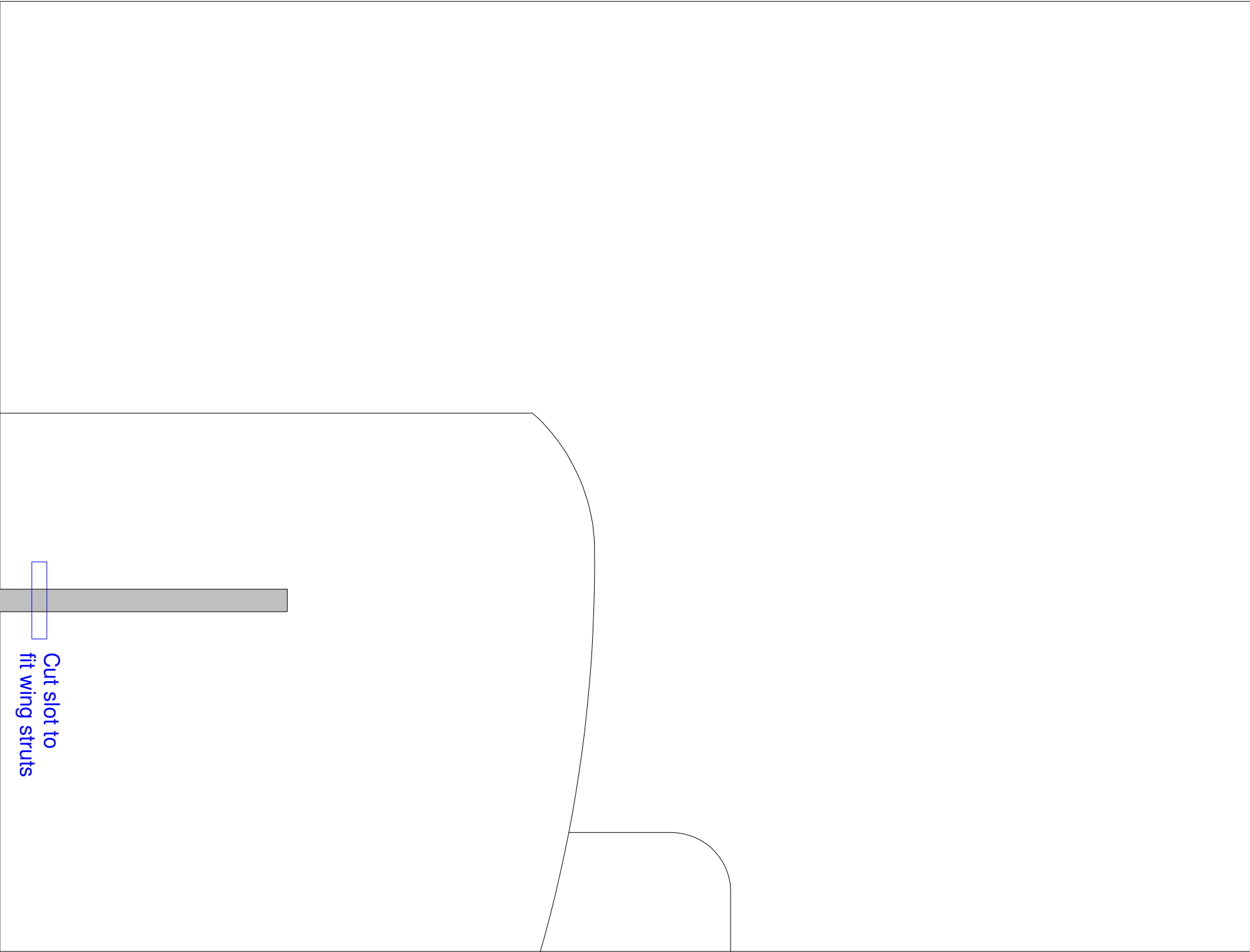

Cut slot to  
fit wing struts