

# ENGINE TEST

by Peter Chinn

## O.S. PET-III .099

a powerful little  
motor for all sport  
flying applications

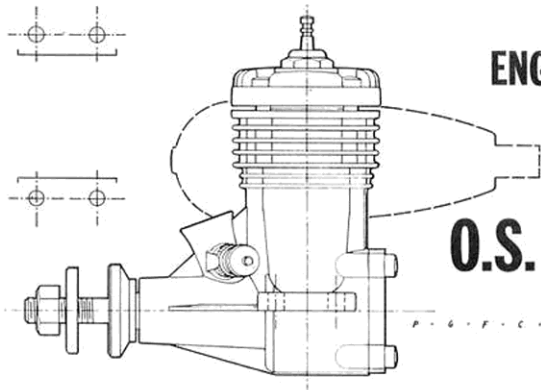

OF THE MANY TYPES of O.S. engines that have been distributed in the U.K. by the KeilKraft organisation over the past dozen years or so, possibly the most popular in terms of numbers sold have been the 3.2 c.c. 'Max-19' and 1.6 c.c. 'Pet-II' models. Both these, however, have recently been superseded by redesigned models, namely the slightly enlarged Max-20 and the completely re-styled 'Mark III' version of the Pet and the first deliveries of both new models are currently being made to KeilKraft stockists.

The very earliest Pet engine appeared some 14 years ago. It was aimed at the beginner and the economy end of the market being the O.S. company's first attempt at a low-priced motor. Some production economies were made, compared with the O.S. 'Max' series, but the engine was, nevertheless, well constructed, reliable and had a better-than-average level of performance. In its latest form, the Pet is still the O.S. company's cheapest engine but it remains a nicely-made little motor and now has, we think, a rather more attractive and purposeful appearance.

All the parts of the Pet-III are new. The most obvious change is the main casting which no longer has radial mounting lugs but now extends upward to include a full-length finned cylinder casing. In place of the Pet-II's integrally-finned cylinder, the Pet-III uses a drop-in cylinder sleeve. This has a very thick wall, allowing internal flute-type transfer ports to be used, and is located at its base by an annular seat in the crankcase. A revised cylinder head, with 2.7 mm. wide squish band surrounding a bowl-shaped combustion chamber, is featured and a small but sensible change is the use of a soft aluminium gasket instead of a composition one.

The crankcase, unbushed, still serves as the main bearing material but there is now a shallow oil groove, correctly located to feed lubricant under crankcase compression to the bearing surfaces. The crankshaft is case-hardened and finely finished and is a good fit in the bearing. It has a rectangular valve port, timed to open at 45 deg. ABDC and to close 180 deg. later. The connecting-rod now has a bronze-bushed big-end and is coupled to a slightly lighter piston by a fully-floating conrod. The piston has a step-type deflector as before. It uncovers the transfer flutes for 55 deg. of crank angle each side of BDC.

The exhaust ports are open for 66½ deg. each side of BDC.

For a long time, the Pet was the only O.S. engine imported into the U.K. for which the manufacturer did not offer a silencer. Now, especially for the Pet-III, the O.S. are making the Type OS-701 silencer which is basically a smaller and more simplified version of the new range of expansion chamber-type silencers made for the current 2.5 c.c. to 13.2 c.c. O.S. Max engines. The 701 silencer is made of pressure-cast aluminium and weighs a modest 0.7 oz. The main body of the unit, including inlet duct and an offset 4.5 mm. i.d. tailpipe, is cast in one piece to which is added a domed nose-cap. There are cooling fins top and bottom and a brass screw-in priming nozzle opposite the exhaust port. The muffler slips over the Pet-III exhaust stack (it is *not* suitable, by the way, for earlier Pet engines) and is retained by a spring around the cylinder casting.

Our test motor was an early (possibly 'pre-production') example obtained in advance of the Pet-III's general release to retail markets. Quite obviously, however, it was not a specially chosen one as we had considerable difficulty, at first, with the needle-valve. This gave somewhat erratic control of mixture

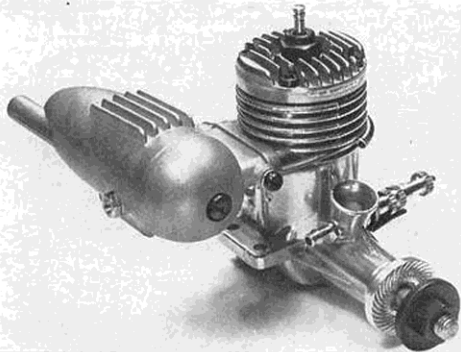

strength when, after running-in, attempts were made to lean it out to optimum full-power setting. We informed the factory of this problem and learned that a modification had, in fact, been made to the spray-bar assembly. On fitting a replacement needle-valve assembly we encountered no more difficulties.

Most small glowplug engines like a reasonable amount of nitromethane in the fuel, so a mixture containing 15 per cent nitro was used for the tests on the Pet-III. In fact, the manufacturer's leaflet, issued since our tests were completed, suggests 5 or 10 per cent. A re-check confirmed that the Pet-III does run quite happily on these milder fuels with only a slight loss of performance.

Very little running-in is required with the Pet-III. There is no reason why the user should not put the engine straight into a model and carry out the running-in process in the air, provided that the needle-valve is set rich for the first 20 or 30 minutes' accumulated running time.

The prop sizes recommended by the manufacturer for the Pet-III (as a starting point) are 7x4 and 8x3. With the silencer fitted, our engine turned up 12,800 r.p.m. on a 7x4 Top-Flite wood prop and 10,600 on an 8x3½ Top-Flite. Other figures included 11,100 on a (fast) 8x4 Power-Prop and 14,800 and 15,600 on two 7x3 Top-Flites. These latter, obviously, would tend to unload to too high a speed in the air, having regard to the engine's peaking speed as indicated by the performance graph. Therefore, the maker's recommendation of a 7x4 should be about right for high performance with the average free-flight, R/C or control-line model. For larger, slower, sport-type free-flight models, an 8 in. dia. with 3 to 4 in. pitch may be better.

The Pet-III's power output of nearly 0.15 b.h.p. at 15,000 r.p.m. on 15 per cent nitro fuel and with silencer fitted is very good indeed for a general-purpose-type engine. The silencer, incidentally, absorbs quite a modest amount of power - only about 10 per cent b.h.p. at the peak - yet effectively muffles the sharp exhaust note that the engine produces with an open exhaust.

General handling and running characteristics were quite good. We found hot restarts a little slow at times but cold starts were easy enough and the Pet showed no inclination to kick or bite. Running qualities were good and the engine held steady r.p.m.

#### SPECIFICATION

Type: Single-cylinder, air-cooled glowplug ignition two-stroke with crankshaft rotary induction valve and plain main bearing.  
Bore: 13.4 mm. (0.5276 in.)  
Stroke: 11.4 mm. (0.4488 in.)  
Swept Volume: 1.608 c.c. (0.0981 cu. in.)  
Stroke/Bore Ratio: 0.851:1

#### Checked Weights:

92 grammes - 3.25 oz. (less silencer)  
112 grammes - 3.95 oz. (with silencer)

#### General Structural Data

Pressure diecast aluminium alloy crankcase/cylinder/main-bearing unit, with detachable rear cover secured with four screws. Hardened steel crankshaft with 8 mm. dia. main journal, 5.5 mm. bore gas passage and 4 mm. dia. crankpin. Lapped, cast-iron, stepped-deflector piston with 3 mm. dia. fully-floating guide-pin. Pressure diecast aluminium alloy connecting-rod with bronze-bushed big-end. Thick-walled steel drop-in cylinder-liner with internal flute-type transfer passages and located by narrow annular seat in crankcase. Pressure diecast aluminium alloy lined cylinder-head with 0.3 mm. soft aluminium gasket and secured to cylinder casing with four screws. Machined aluminium alloy prop driver keyed to flat on crankshaft. Brass, spray-bar-type needle-valve assembly. Beam mounting lugs.

#### OPTIONAL EXTRAS

- (i) Expansion chamber-type silencer, type O.S.-701.  
(ii) Barrel-throttle valve (for use with existing spray-bar assembly).

#### TEST CONDITIONS

Running time prior to test: 1 hour

Fuel used: 15 per cent nitromethane, 25 per cent Duckhams Racing Castor-oil, 60 per cent methanol  
Glowplug used: O.S. No. 9 (medium reach, platinum filament)

Air temperature: 21 deg. C (70 deg. F)

Barometric Pressure: 30.25 in. Hg.

Silencer: O.S.-701 expansion chamber type

readings through a wide range of load speeds - i.e. from 7,000 r.p.m. up to 18,000 r.p.m. There was no power loss as the Pet warmed up from cold and, on dismantling it after test, we found the engine very clean and, as expected, bearing no evidence of having been overheated or stressed in any way. The O.S. No. 9 glowplug survived all running-in and testing.

In all, this seems to be a most worthy successor to the popular Pet-II model!

**Power/Weight Ratio** (as tested with OS-701 silencer):

0.60 b.h.p./lb.

**Specific Output** (as tested with OS-701 silencer):

92 b.h.p./litre.

