

O.S Max .10RC



Engine Test

By Peter Chinn

O.S. MAX-10R/C

Very useful 1.76cc. engine with characteristics of bigger units

Heading photo on opposite page shows the Max-10 R/C with the O.S. Jetstream Type R/C-S silencer fitted.

There have been few serious attempts, in Britain or the U.S., to produce pukka R/C engines in the under 2 ½ c.c. capacities. It can be argued that the majority of small single-channel models are built merely as rudder-only machines and that there is no point in producing a 1 ½ cc. engine with effective throttle control if the throttle is seldom going to be used. Presumably this is the reason why, for example, our largest manufacturer of small engines does not include among them a single R/C motor.

The position is a little different in Japan where single-channel systems commonly include much more than just rudder control and where throttle control is added as a matter of course. With single-channel servos replacing escapements and the availability of three position throttle servos (giving slow, medium and fast positions instead of the earlier fast and slow set-up) the small motor possessing a throttle performance comparable with that of large engines, now has a place in the scheme of things.

Such an engine is the O.S. Max-10 R/C. In size and weight this motor comes in the popular 1.5 c.c. - .099 cu. in. group, but, in general design and construction, it is more closely related to larger designs and to the 5 cc. O.S. Max-S 30 R/C engine in particular. Like the S.30, it is a loop-scavenged shaft-valve motor with a one-piece body casting, drop-in cylinder liner and a barrel type carburettor with jet feeding into the

centre of the barrel. Construction and finish, generally, are to higher standards than one usually finds with "beginner" type small engines and, in consequence, the price of the engine, while quite competitive, is a little higher than those of the simpler O.S. Pet 09 R/C and other low-priced small motors.

The Max-10 uses a hardened, counterbalanced crankshaft having a 9 mm. (.354 in.) dia. journal (large for an engine of this size) and a generous, 6.5 mm. dia., gas passage. A rectangular valve port registers with a parallel sided intake aperture, in the cast-in phosphor bronze main bearing, to give a 40 deg. ABDC to 45 deg. ATDC valve timing. The cylinder liner, finely finished both inside and out, is closely fitted to the cylinder casting and is located in the usual way by a flange at the top. The piston is of Meehanite cast-iron with a flat crown and filleted baffle. It is coupled to a machined connecting-rod of 24.ST3 duralumin by a 3.5 mm. dia. hardened tubular gudgeon-pin, which is fully floating, with brass pads. Designed cylinder port opening periods are P5 deg. exhaust and 105 deg. transfer. These were checked correct to within one degree on our test sample. The cylinder head is of diecast and machined aluminium alloy and has a hemispherical combustion space interrupted by a slot for piston baffle clearance. The head is recessed for a 15 thou, soft aluminium gasket and is secured with five screws.

On first acquaintance with the Max-10 R/C, we were sorry to see that the air-bleed control featured on all other Max R/C engines had been omitted from the Max-10 carburettor. In practice, however, it was

O.S Max .10RC



At left parts of the Max-10 R/C are well finished and accurately fitted. Motor's design and construction follows larger engine practice.

quickly found that, on the Max-10, this lack of a means of adjusting low' speed mixture strength was not disadvantageous since the engine idled as well as, if not better than, any other R/C engine of similar size. Although the carburettor casing appears to have been originally intended for an idle-stop screw, this is not fitted to the production model and the low- speed position of the throttle, therefore, has to be set by servo linkage arm adjustment or by adjusting the position of the throttle arm on the throttle barrel. Actually, the absence of a stop is regretted only when one is bench testing the motor.

In all other respects, the carburettor resembles those of the larger O.S. R/C engines, including the well fitted ground throttle barrel with, feeding into its centre, a jet that is adjustable so that choke area may be varied for more suction and less power or vice versa. The needle-valve and tee-fitting fuel inlet are on the left hand side of the engine and do not interfere with the movement, on the opposite side, of the throttle arm. This latter is coupled to a centrally pivoted exhaust blanking plate which, however, will normally be discarded in favour of a silencer. The standard O.S. Jetstream Type "S" silencer fits the engine.

Performance

Our tests on the Max-10 R/C were carried out with the Type "S" silencer fitted, including the ½ inch extension adaptor and rear nozzle ring. We found the Max-10 extremely easy to handle. It would start from cold equally well with the throttle open or in the idling position and, usually, after merely choking the intake

for three or four preliminary turns of the prop. Warm, closed-throttle restarts were practically instantaneous and, with the tank in the correct position and the fuel line full, without choking or priming. Running-in, as such, was not really necessary. Naturally, we exercised some caution at first, but it was quickly established, after a few minutes running, that the Max-10 was quite free from any tendency to overheat and tighten up.

Typical prop speeds achieved with the Max-10 R/C included 7,900 r.p.m. on a 9 x 4 Top Flite nylon. 10,000 on an 8 x 4 Tornado nylon, 11,100 on an 8x4 Power Prop wood. 11,900 on a 7 x 4 Tornado nylon and (rather too fast for best performance) 14,200 on a 7x3 Trucut wood. On the 8 x 4's the Max-10 idled consistently at 2,500 r.p.m., which is extremely good for an engine of this size, and also had a useful "inbetween" range of speeds.

Maximum power developed by the Max-10 R/C on test was, as our performance graph shows, just over 0.14 b.h.p. at slightly below 14,000 r.p.m. This is quite good for an engine of this size running on 5 per cent nitro fuel and with silencer fitted. We also tried the engine on more powerful fuels. These improved maximum torque but did not make a really worthwhile improvement to top-end power and we would regard standard, lower-priced mixtures as quite adequate for this motor. We also checked the power loss caused by the silencer and found this to be very small only about 5 per cent in fact. This is due, no doubt, to the relatively generous volume of the Jetstream Type "S" silencer (originally designed for the O.S. 15 and 19) when fitted to the Max-10.

In all, we would rate the Max-10 R/C high among currently available small R /C engines and well worth the attention of the modeller who aspires to a better standard of engine performance for small R/C models.

Power/Weight Ratio as tested with silencer): 0.60 b.h p./lb.

Specific Output (as tested with silencer): 81 b.h.p./ litre.

O.S Max .10RC

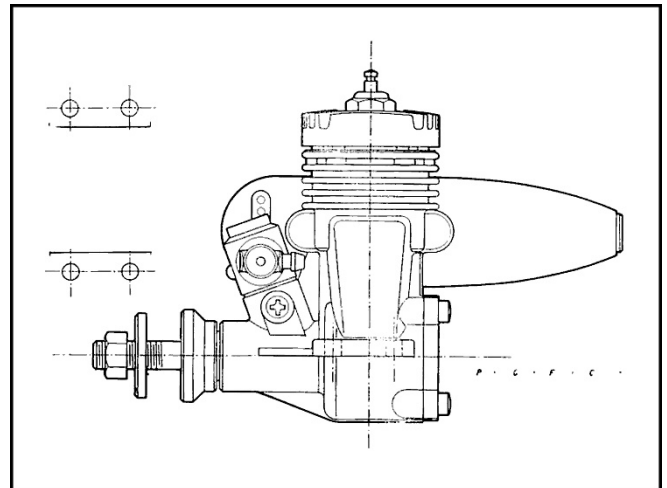
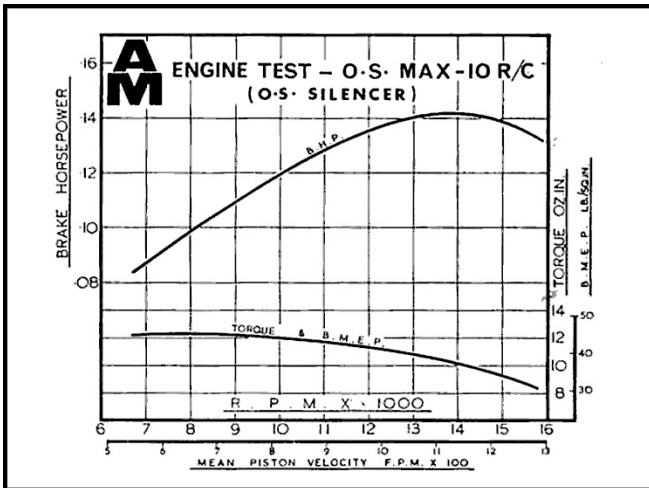

SPECIFICATION

Type: Single cylinder, air cooled loop-scavenged two-stroke cycle, glow-plug Ignition. Crankshaft type rotary-valve Induction. Bronze bushed main bearing.

Bore: 13.4 mm., (0.5276in.) Stroke: 12.4 mm. (0.4882in.)

Swept Volume: 1.749c.c. (0.1067 cu. In.)

Stroke/Bore Ratio: 0.925:1.

Weight: 3.2oz. (3.8oz. with Type S silencer).

General Structural Data

Pressure diecast aluminium alloy crank case/cylinder-block/front-housing unit with cast-in phosphor-bronze main bearing and drop-in unhardened steel cylinder-liner. Detachable p.d.c. aluminium alloy crankcase back-plate secured with four screws. Case-hardened steel counterbalanced crankshaft with 9 mm. dia Journal, 6.5 mm. bore gas passage and 4 mm. hollow crank-pin. Lapped Meehanite piston with battle and case-hardened 3.5 mm. tubular-gudgeon-pin with brass pads. Machined high-duty duralumin connecting-rod. Pressure diecast aluminium alloy cylinder-head with machined joint face, recessed 0.4 mm. soft aluminium gasket and secured with five screws. Machined duralumin prop driver. Pressure diecast aluminium alloy carburettor body seating on rubber grommet in intake boss and secured with two screws. Ground brass throttle barrel in honed bearing surface in carburettor body. Plated brass needle-valve assembly. Beam mounting lugs.

TEST CONDITIONS

Running time prior to test: 1 hour.

Fuel used: 5 per cent nitromethane, 25 per cent Duckhams Racing Castoroil, 70 per cent I.C.I. Methanol.

Glow-plug used: O.S. No. 7 bar type, platinum filament, 1.5 volt medium (3/16 in.) reach.

Air temperature: 58 deg. F.

Barometer: 29.8 in. Hg.

Silencer Type: O.S. Jetstream Type S.

The Aeromodeller Engine Test report in the August issue was on the O.S. Max 10 R/C engine and, in this, we regretted the absence of the usual O.S. idle stop screw on the carburettor. However, no sooner had this report been published, than we were shown, by Mr. Ogawa during his visit to the U.K., a revised version of the Max 10 R/C carburettor in which the lamented adjusting screw has now been incorporated. All future deliveries of Max 10 R/C engines will include the revised carb. Incidentally those who mix boats with their aeromodelling may be interested to know that marine conversion equipment is now being made for this engine. It includes the usual O.S. style water-cooled cylinder-head and crankcase back-plate and, of course, a machined brass flywheel.

O.S Max .10RC



More: https://flyinghlsat.com/search.php?search_keywords=O.S-Engines