

## O.S Max S-35 and S-30 R/C

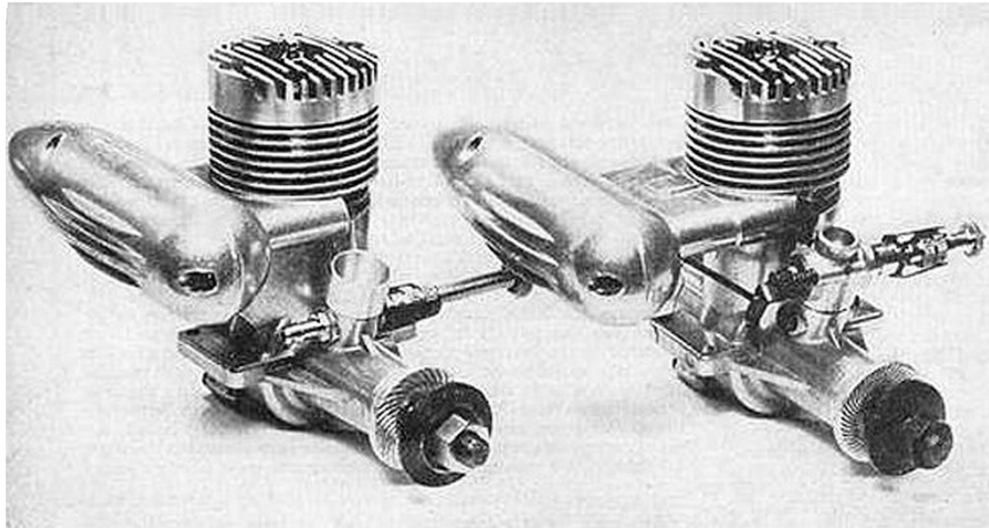

SPECIAL  
"DOUBLE-  
FEATURE"  
**ENGINE  
TEST**

by Peter Chinn

### **The O.S. MAX S-35 and S-30 R/C**

It is two years since we last dealt with an O.S. engine in the M.A. Tests series. During this period the O.S. range has been further expanded and, with sonic thirty models on its current production list, the Ogawa Model Manufacturing Company Ltd., now has the largest range of model engines produced by any manufacturer anywhere in the world. These, together with O.S. radio control equipment, are built in a modern well equipped factory which includes a large proportion of active model enthusiasts among its personnel, including a permanent staff of two engaged solely on model engine design and experimental work.

Since our test on the Max-19 engine early in 1963, a dozen new O.S. models in six different capacities, have been announced. Moreover, nearly all the then existing models have been either improved or replaced. It is, obviously, quite impossible to keep up to date with all O.S. engines in the M.A. Tests series, but to help cut into some of the backlog of those still awaiting test, we are making the present report a "double" test, covering the two current "Max-S" models, namely the 5.83 c.c. S.35 (intended for C/L stunt use) and the 4.86 c.c. S.30RC, which is aimed at the intermediate or multi trainer R/C field. Coming just within the new SMAE 10 c.c. total maximum displacement limit for twin or multi-engine models, the S.30RC, with its moderate weight and excellent throttling, should also be a good choice for a multi-channel twin-engine model.

As our side-view drawing suggests, the S.35 and S.30RC are based on the same body casting and the only obvious external differences are in the carburettor and exhaust system. Several other differences are to be found inside, of course, but many parts of the two engines are interchangeable and one advantage of this is that anyone wishing to use slightly more power than that obtainable with the S.30RC. can very easily convert the S.35 to an R/C version by fitting an S.30RC throttle system. In the United States, the S.35 is in fact, being offered as an "S.35RC" model, so converted. Here we might also add that the American market versions have a simplified exhaust throttle valve of the centrally pivoted "chopper" type (i.e. very similar to that of the Merco 49 and 61) instead of the enclosed butterfly type as on the current Max 19 and 15 engines) fitted to British imports.

Actually, the type of exhaust throttle valve supplied is not now significant in the U.K. since, with the new SMAE silencer ruling, the exhaust throttle unit will normally be removed entirely. The standard O.S. Jetstream "L" type silencer fits both the 30RC and the 35, with or without the optional extension duct provided.

## O.S Max S-35 and S-30 R/C

Alternatively, the radio-control engine (including 35 R/C conversion) can be fitted with the Jetstream RCL type silencer which has a built-in butterfly valve for coupling to the carburettor throttle.

To understand the manufacturer's reasons for introducing these two "Max-S" type engines, one must first look back ten years to when the first of the Max 35 series of engines was produced. At that time, the main use of .35 cu. in. engines was for control-line stunt. Later, combat and rat-racing came along and more power became necessary. O.S. answered the call with the Max-II and Max-III 35's. But combat, and rat-racing (American style, that is) have both become more and more demanding and engines have departed more and more from the essential requirements of a stunt motor. The answer is to build specialised engines for each class and this is what O.S. have now done. The "Max-S" gets back to the classic stunt requirements of moderate weight, moderate compression ratio, and a small crankcase and shaft for maximum primary compression. Here, very high power, or operating speeds above 12,000 r.p.m., are rarely called for. Meanwhile, to cater for the combat and rat-racing fiends and 16,000-18,000 r.p.m. speeds, O.S. are introducing two models in the new high performance, ball-bearing "Max-H" series, the 35C and 40RR.

Broadly speaking, a good C/L Stunt motor usually makes the basis of a good R/C acrobatic engine, so, while a .30 cu. in. unit had not been expected, it was not surprising that O.S. should decide to produce an R/C engine based on the S.35. The intention was to produce a motor for multi-trainer or small "full house" models. All initial flight tests were therefore carried out with a Tauri. Actually, the main casting and crankshaft of the S.35 are unaltered in the S.30RC, the difference in capacity being accounted for by a reduction in bore of 1.8 mm. A thicker cylinder liner takes up the bore reduction, the bore of the cylinder block being unchanged.

The Max-S was the first O.S. engine to use a one-piece crank- case/front-housing/cylinder-block casting, a form of construction that is also featured by the new Max-H series engines.

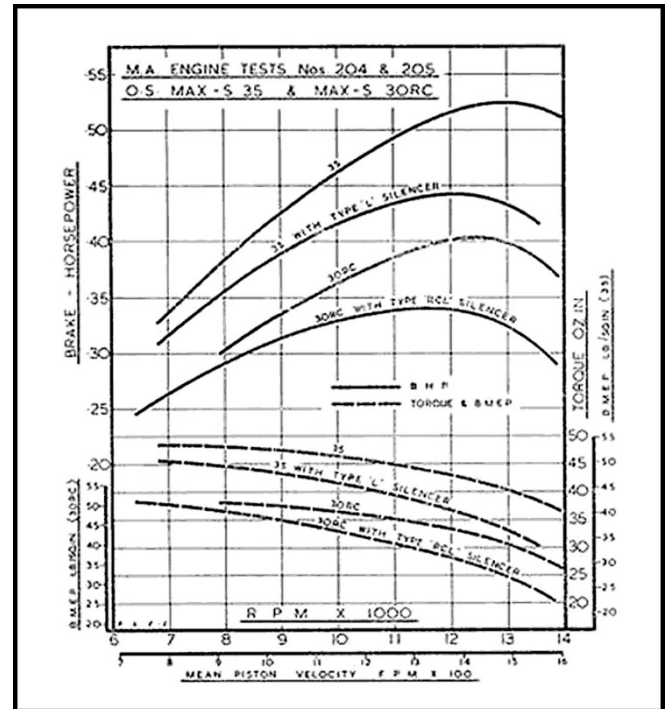

In the accepted stunt engine manner, the S.35 carburettor is placed close to the cylinder so that effective crankcase volume is not needlessly increased by a long shaft passage. The crankshaft has an 11 mm. journal (compared with 13 mm. on the Max-H series) which amply accommodates the 7.8 mm. gas passage adequate to an engine of this type. Bearing areas and counterbalancing are well taken care of. The shaft, which is case-hardened and runs in a well-finished bronze bearing, has a full 3/4 in. dia. crankpin. Counterbalance consists of a crescent counterweight, plus cutaway web flanks each side of the crankpin which, itself, is drilled for lightness. A fully machined conrod is now used. This is less bulky than the previous bushed diecast rod and, requiring less clearance between (he crankpin and crankcase, has permitted a smaller diameter crank-case. The deeply finned cylinder head now features a hemispherical combustion chamber with recessed soft aluminium gasket and central plug location, the recommended glow-plug for both models being the O.S. No. 7 shielded type.

The S.35 is fitted with the familiar O.S. plated spraybar assembly with its neat flexible needle-valve control and positive double ratchet. This passes through the intake boss (and is reversible) holding in position a machined dural venturi, scaled by a rubber grommet.

# O.S Max S-35 and S-30 R/C

In the S.30RC, the venturi and needle-valve assembly arc replaced by a compact throttle type carburettor, which is held in place by screws through the normal spraybar holes in the intake boss. The R/C carburettor has a pressure diecast aluminium body anti is a reduced scale version of that fitted to the Max-50RC engine.

Both engines arc of neat appearance and nothing is skimped construction-wise. All castings are very nicely turned out and all machined and ground parts are equally well executed.

## O.S.Max-S.35 Specification

**Type:** single-cylinder, air-cooled, loop-scavenged two-stroke cycle, glow-plug ignition. Crankshaft type rotary-valve induction. Baffle piston and central ignition plug in hemispherical combustion chamber. Optional silencer.

**Bore:** 20.6 mm. (0.8110 in.). **Stroke:** 17.5 mm. (0.6890 in.).

**Swept Volume:** 5.833 c.c. = 0.3559cu. in.

**Stroke/Bore Ratio:** 0.850:1.

**Weight:** 6.7 oz. (7.7 oz. with O.S. Jetstream Type L silencer).

## General structural data

Pressure-diecast aluminium alloy crankcase/front housing/cylindce block unit with cast-in bronze main bearing bush and detachable back-plate secured with four Phillips screws. Counter-balanced, case-hardened steel crankshaft, ground on all working surfaces, with 11 mm. main journal and 6.35 mm. dia. hollow crankpin. Meehanite cast-iron piston with flat crown, straight baffle and with internal annular stiffening web above gudgeon-pin bosses. Piston diameter relieved approximately 0.003 in. on diameter for 1 mm, below crown, with full length parallel lapped skirt below. Connecting rod machined from 24ST3 aluminium alloy, unbushed, with two lubrication holes at big end. Fully floating 5 mm. diameter case-hardened tubular gudgeon-pin with brass end pads. Leaded steel, ground and lapped, drop-in cylinder liner, located by flange at top. Pressure diecast and machined deep finned cylinder head with brass thread insert for glow-plug and recessed for blowout-proof

0.4 mm. soft aluminium head gasket. Cylinder head scarred with six Phillips head screws. Machined duralumin prop driver keyed to flat on crankshaft. Blued steel prop retaining washer and hexagon nut. Nickel-plated brass spraybar and needle-valve assembly. Machined carburettor venturi. Provision for conversion to R/C type by filling 30RC type carburettor. Exhaust duct internally drilled and tapped for O.S. Jetstream Type L silencer or for exhaust throttle-valve unit or Jetstream Type RCL silencer. Beam mounting lugs.

## Test conditions

**Running time prior to test:** 2 hours.

**Fuels used:** (a) 70 per cent I.C.I. methanol.

30 per cent Duckham's Racing Castor-oil (running in): (b) 70 per cent I.C.I. methanol, 25 per cent Duckham's Racing Castor-oil, 5 per cent nitromethane (performance tests).

**Ignition plug used:** O.S. No. 7 shielded type glow-plug (platinum filament).

**Air temperature:** 41 deg. F (5 deg. C).

**Barometer:** 30.6 in. Hg.

**Silencer Type:** O.S. Jetstream Type L, without extension duct but including restrictor rings in baffle and outlet nozzle.

## Performance

Since the use of silencers is now obligatory, all running-in and nearly all testing on the S.35 were done with a Jetstream Type L silencer fitted. At the conclusion of these, the engine was re-cheeked on the dynamometer without the silencer, for the purpose of discovering how much power-loss was attributable to the silencer and also how the S.35 compared for power with other stunt 35's which, hitherto, have only been tested without silencers.

For the record, we will therefore dispose of this latter point by reference to the upper power curve on the performance graph which indicates a maximum b.h.p. just over 0.52 at 13.000 r.p.m. This is less than for the older multi-purpose Max-III 35 under similar conditions of fuel and climate (as one, would in fact,

# O.S Max S-35 and S-30 R/C

expect) but is a good average figure for a stunt 35 and compares favourably with that of the Fox 35.

With the silencer fitted, peak power was reduced to a little less than .45 b.h.p. at just above 12,000 r.p.m.. for a power loss of approximately 15 per cent. Although this sounds a lot, it is, of course, equivalent to an r.p.m. loss of only a little over 5 per cent, while, at speeds below the peak, loss is somewhat smaller only about 400 r.p.m. if the engine is propped for a static speed of around 10,500 on a 10 X 6. This is quite reasonable and a small price to pay for the very worthwhile degree of exhaust noise reduction obtained with this light and compact silencer unit. (It compares strikingly, in fact, with some of the cruder types of mufflers recently tested particularly some of those for radial port diesels which have reduced power by as much as 30-35 per cent).

General handling qualities of the S.35 were good. Starting characteristics were quite orthodox and presented no difficulties when the silencer was fitted. The Jetstream silencer has a small built-in nozzle opposite the exhaust to allow fuel to be injected into the exhaust port to assist a cold start: otherwise intake priming or choking can be used.

**Power/Weight Ratio (as tested):** 1.26 b.h.p./lb. without silencer. 0.93 b.h.p./lb. with silencer.

**Specific Output (as tested):** 90 b.h.p./litre without silencer. 76 b.h.p./litre with silencer.

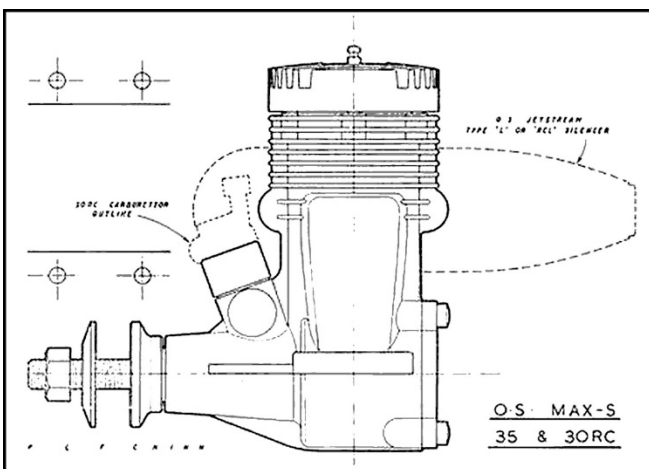

## O.S. Max-S.30RC Specification

**As for S.35 except for the following:**

Coupled carburettor throttle and exhaust valve.

**Bore:** 18.8 mm. (0.7402 in.).

**Swept volume:** 4.858 c.c. (0.2964 cu. in.).

**Stroke/ Bore Ratio:** 0.931:1. Weight: 7.8 oz. (8.7 oz. with Jetstream Type RCL silencer).

## General structural data

**As for S.35 except for following:**

Pressure diecast aluminium alloy carburettor body with brass throttle barrel. Self-locking adjustment screws for idle setting and slow running (air-bleed) mixture adjustment. Non rotating nickel-plated brass needle-valve assembly mounted on left-hand side with tee fitting for fuel tube. Pressure diecast exhaust duct extension containing exhaust damper valve linked to carburettor throttle and interchangeable with Jetstream Type L or RCL silencer.

## Test conditions

**Running time prior to test:** 1 hour.

**Fuels and ignition plug used:** As for S.35 above.

**Air temperature:** 46 deg. F (8 deg. C).

**Barometer:** 30.3 in. Hg.

**Silencer Type:** O.S. Jetstream Type RCL with extension duct and restrictor ring in outlet nozzle.

## Performance

As with the S.35, running-in and most testing on the S.30RC were carried out with the silencer fitted. Actually, the running-in period of one hour was given more as a matter of procedure than of necessity, since it was found that the S.30RC could be leaned out almost immediately from new without overheating or loss of performance. The engine was, in fact, given a series of slightly rich runs totalling no more than 30 minutes and then given its head for a further 30 minutes. Possibly, a slight improvement in performance may occur with extra running, but our example was well up to expected levels of power, starting and throttling within this period.

For those who look for economy of operation in an R/C engine, it may be mentioned that the S.30RC ran perfectly on a straight 3/1 methanol and castor-oil

## O.S Max S-35 and S-30 R/C

fuel mixture. Propped for peak revolutions on the bench, it was then about 250 r.p.m. down on the speed achieved on 5 per cent nitromethane fuel, but throttled just as well as with a steady idling speed of under 2,500 r.p.m.

Maximum outputs reached by the S.30RC on test were a little over 0.40 b.h.p. at 12,500 r.p.m. less silencer and 0.34 b.h.p. at approximately 11,600 r.p.m. with silencer. More significant to the user, perhaps, is the fact that the latter figure approximately corresponds to the in-flight performance on a 10 X 4 Tornado nylon prop combined with very reliable throttling down to an even 2,200-2,400 r.p.m. In this respect, the S.30RC should, it seems, be well suited to modern multi trainers where, hitherto, the choice of R/C engines has been mostly limited to 19's (power ant to be marginal on take-off or in vertical manoeuvres especially when fitted with silencer) or to ,35's which may be a shade toss heavy or too powerful. 10 X 3 ½ or 9 X 5 (Top Flite wood props, 11,200-11,400 r.p.m. static) are the smallest practical sizes if one wishes to make full use of the S.30RC's performance. A 10 X 4 as we have suggested, or a 10 X 5 should be as good as anything for a multi trainer, although the engine also turned bigger props quite well, reaching 9,000 on an 11X4 Top Flite nylon and 10,100 on an 11X3 Top-Flite wood. All these figures were with the silencer fitted.

Starting qualities of the S.30RC were good, using orthodox techniques. To restart the engine warm, we found it particularly effective to choke the intake for 4-6 turns of the prop (needle- valve in running setting), close throttle to } open and the engine would then start first flick. Throttle settings were non-critical, needing little or no readjustment from the factory settings.

Occasional inspection of the silencer mounting screws is advisable. On test, no trouble was experienced when the silencer was attached direct to the engine but the mounting screws tended to loosen when the duct extension was used.

**Power/Weight Ratio (as tested):** 0.83 b.h.p./lb. without silencer. 0.63 b.h.p./lb. with silencer.

**Specific Output (as tested):** 0.84 b.h.p./litre without silencer. 0.70 b.h.p./litre with silencer.



**1963  
MAX-S35  
5.83c.c.**



**1964  
MAX-S30R/C  
4.86c.c.**

