

All the many parts of the .15R Clever design by Bill Wisniewski combined with top grade K&B construction makes top contest performer.

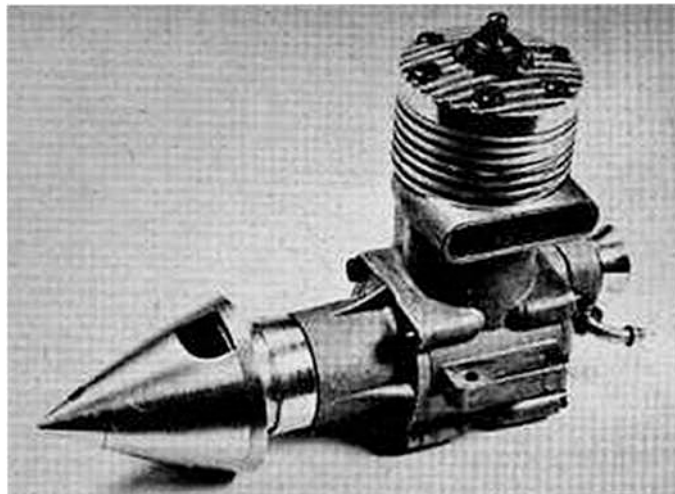

Almost one-half horsepower at 20,000 rpm from now -15R nearly doubles the power of the old Torpedo .15 which was tops for years.

Engine Review...K&B Torpedo .15R

► "The Torpedo 'Series 61' engines will produce greater h.p. per cu.in. than any other model engines."

So runs the latest K&B ad.

As yet, we cannot speak from experience of the other two Series 61 engines, the 29R and 35, but, so far as the .15R is concerned, tests of our sample confirm the veracity of the K&B claim. On test, our .15R produced a specific output of 3.19 brake horsepower per cubic inch displacement. And that, baldly, is the highest ever that we have recorded in thirteen years of horsepower testing around 250 different engines.

At present, model engine design is in a period of intensive development. Whereas, a year ago, 3 bhp/cu.in. would have been almost unbelievable for a production model motor and would have put the .15R so far out in front as to be in a class all of its own, it is only fair to remark that, just now, one or two other top class motors are getting mighty close.

The important thing, however, is that the American modeler now has motors that are more than a match for anything that the rest of the world has to offer and, in international contests,

Wonder if the model builder appreciates the amount of time and money that is spent by the engine manufacturers in producing the fabulous new engines for 1961. In this review we cover the first of the '61 K&B's.

by P. G. F. CHINN

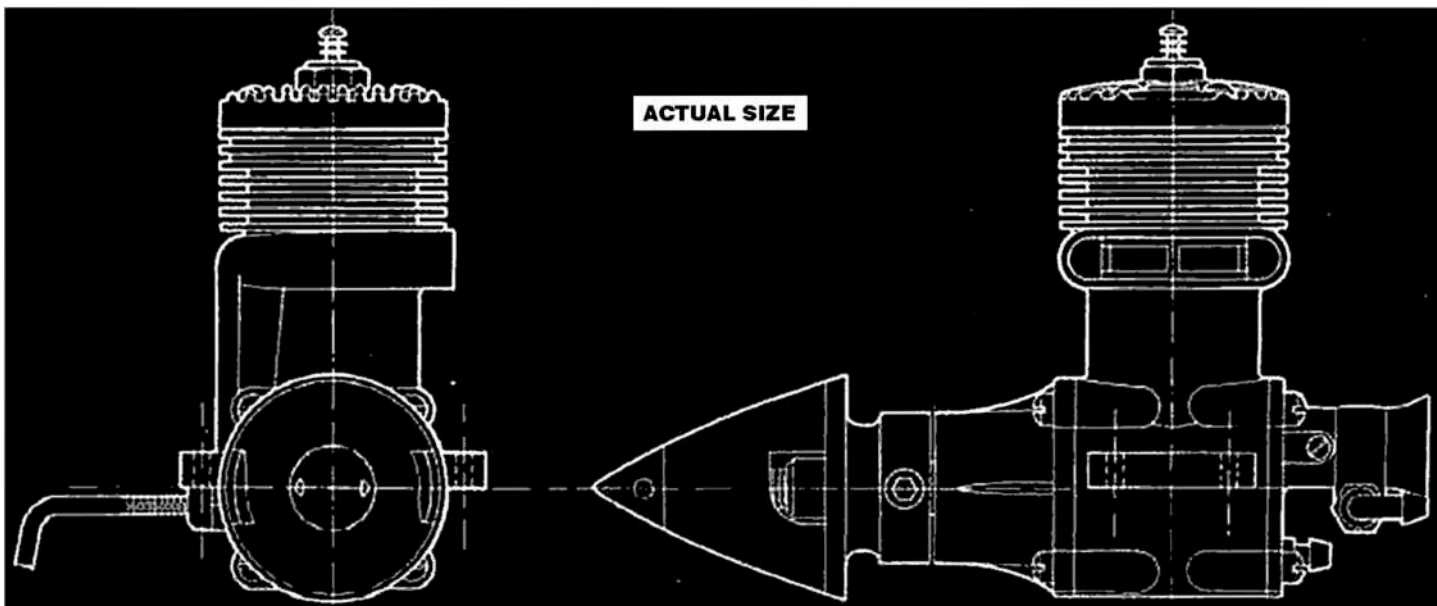
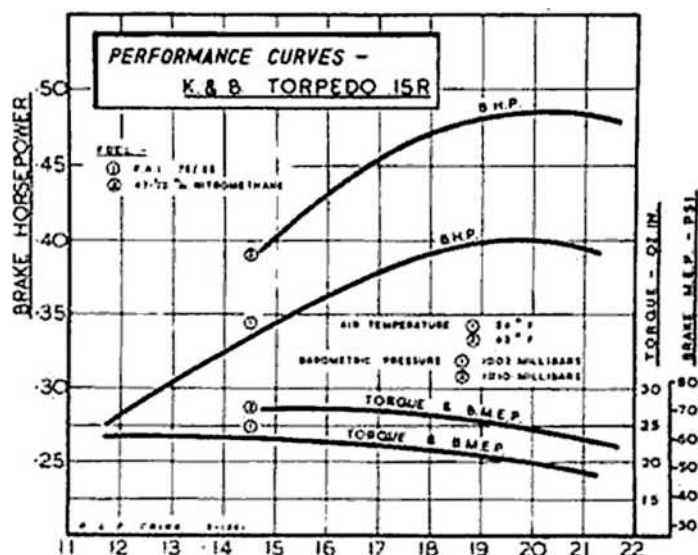

Engine Review...K&B Torpedo .15R

he no longer labors under the handicap of a shortage of competition type .15 class motors. Up until a decade ago, top grade U.S. engines were the preferred choice of contest men the world over. Then came the Half-A, the simplification of larger engines and low-priced motors for the millions.

The expensive racing engines gradually fell victims to the new trend: the requirements of a few contest experts were apparently not sufficient to encourage manufacturers to continue their development and, as the cheaper type motors began closing the performance gap, existing racing engines, one by one, were dropped from production.

During this period, however, international competition flying assumed increasing importance and the 2.5 c.c. (.15 cu.in.) displacement became the FAI recognized class for World Championship speed, free flight and team racing events. In Europe, the .15 has long been a favored size (there being no AMA class until more recently) and apart from free flight successes in 1953 and 1954 (shaft valve Torpedo 15) no American 2.5 c.c. engine has actually won an individual World Championship, the honors among available commercial designs, mostly going to the British Oliver, Italian Super Tigre and Japanese O.S.

Now, we venture to suggest, things may well be different and there are better prospects of American success, in both FAI speed and free flight than at any time in the past. So far as the K&B .15R is concerned, here is an engine that is appreciably more powerful than any stock European contest .15 although what the State sponsored Czech MWS and Hungarian MOKI model research departments may have up their sleeves still remains to be seen.

However, enough of this digression.
Let's get back to the .15R.

The first thing to notice about this engine is that it returns to the classic racing engine layout of twin ball bearings in a separate front plate assembly and a back plate disk induction system. Design wise, the engine is basically Bill Wisniewski's racing .15 that, last year, powered what was, undoubtedly, the world's fastest

.15 engine speed model, even though it was relegated to second place in the FAI finals.

One of the most interesting features of the design is the crankshaft which, unlike most modern shafts (almost invariably machined in one piece) is assembled from three individual parts. Firstly, the actual shaft with disk or flywheel type web is machined from "Stress-proof" high tensile steel. The web is a full Vi-in. thick and is milled on the periphery only, each side of the crankpin hole, to provide the necessary counterbalance mass opposite the crankpin. The milling, however, is in the form of 3/10 in. wide slots so that full circular disks remain front and back. The periphery is then fitted with a ¼ inch wide aluminum rim, covering the milled slots. This arrangement permits a greater degree of crankcase "packing" and thus a higher primary or base compression ratio than is possible with an orthodox counterbalanced shaft. The crankpin, .179 in dia. and partially drilled for lightness, is made separately so that it can be hard plated for improved bearing life. The process used is "Electrolixing" which gives a surface of extreme hardness and the pin is then lapped to a 4 micro-inch finish before being pressed in.

The shaft, which is relieved at the center to form two 1/4 in. dia. journals, is carried in two 5/8 in. o.d. Barden 8-ball precision bearings, in a pressure die cast housing. This is attached to the main crankcase/cylinder block casting with four 3-48 screws and the back plate is secured in the same manner. All castings, in #380 die casting aluminum alloy, are extremely cleanly cast, internally as well as externally and are also extensively machined. There are no ragged edges or casting flash, for example, the bottom surfaces of the mounting lugs are machined for perfect alignment and joint faces are machined for metal-to-metal joints, eliminating the need for gaskets.

The piston is of steel with an Electrolyzed surface which assumes a bright mirror finish as the engine becomes broken in. The piston skirt is relieved below the wrist-pin centers, has two skirt bypass ports of 7/32 in. diameter and a straight, filleted baffle.

Engine Review...K&B Torpedo .15R

It couples to a hot forged 2014 Alcoa aluminum connecting-rod via a full-floating 5/32 in. dia. tubular wrist pin with aluminum end pads. The piston runs in a Meehanite cast iron cylinder sleeve, the top flange of which makes the joint with the pressure cast and machined cylinder head.

The back plate induction assembly is another interesting feature. Air enters through a well shaped venturi with 1/4in. dia. choke. Fuel is picked up from no less than six tiny jet holes, spaced at 60 degree intervals around the venturi throat. A tight-fitting collar surrounds the venturi and contains the needle-valve and the complete assembly is retained in the back plate by a set-screw which allows the needle control to be located in a variety of positions to suit individual model installations.

From the venturi, entry widens smoothly into a 90 degree segment aperture in the back plate face. The valve rotor is of an undisclosed molded material, very rigid but very, light and offering a minimum of unbalance to the rotating mass. It is very freely mounted on a steel pin pressed into the back plate. The valve gives a measured 190 degree induction period, timed to open at 35 deg. after BDC and close at 45 deg. after TDC Unlike some recent high performance motors, exhaust lead is not reduced to the point of being almost non-existent and is, according to our measurements, approximately 8 degrees of crank-angle, the actual exhaust and bypass periods bring, respectively, 140 deg. and 124 deg.

The 15R comes complete with a spinner assembly which is nil part of the engine. The spinner back plate is integral with the drive hub. It is locked to the front end of the draft with an Alien setscrew which engages a flat on the shaft end. 'Flic prop is retained by a hexagon nut and washer on a 3/16 in. dia. stud which screws into the hub and the conical spinner nut. Securing the spinner shell, screws onto the stud end. All spinner parts are diecast and machined alloy.

Our 15R was given a careful break-in. consisting of a long series of short rich runs under light load and totalling approximately 1 1/2 hours, on straight 70/30 methanol and castor oil fuel. It was then given a

further hour's intermittent running on other fuels to check its readiness for full tests. We used a Veco pressure tank connected to the back plate pressure top fitting supplied with the engine.

Dynamometer tests were first undertaken using the new regulation FA I speed fuel formula consisting of 75 percent methanol and 25 percent castor-oil. The lowest speed at which the .15R was tested was 11,000 rpm, but it soon became clear that this is an engine that ought to be given its head at all times. At these low speeds, the engine tended to lose power as it warmed up from cold and it was only at speeds above 15,000 rpm that the true potential of the 15R's performance started to become apparent. The graph shows the performance curves on straight fuel and it will be noted that horsepower reached its peak at approximately 19,500 rpm for an output of just 0.40 bhp. This is exceptional but the high peaking speed would probably call for reducing the makers recommended speed prop sizes a little, in order (when using such fuel) to allow the engine to peak in the air.

There is one snag to the high standard of performance of which the 15R is capable namely, plug consumption. At 19-20,000 rpm speeds, even on straight fuel, the engine burned out plugs rapidly. In fact, our tests were brought to a close before we could make rpm checks on various speed props and fuels, solely because we exhausted our stock of spare KB-1S plugs. (Incidentally, we might add that there seems to be little doubt that the KB-1S plug is the best plug, performance wise, for this engine. We tried other types but the best did not equal the KB-1S and the worst dropped rpm by more than 1,000 rpm near the peak). This problem of plug failure is one that is currently occupying the attention of the makers who hope to come up with a solution shortly. Meanwhile, we must console ourselves with the thought that only through a startling, and very welcome, increase in engine performance, has this problem arisen.

For our tests on "hot" fuel, we chose a mixture in accordance with the manufacturer's recommendations—i.e. a blend of nitromethane, castor-oil, nitrobenzene, polyoxide oil and methanol,

Engine Review...K&B Torpedo .15R

with the nitro methane content at 47 1/2 percent midway between the upper and lower limits specified. On this fuel, torque rose by 15 percent to 27 oz.in. at between 15,000 and 17,000 rpm, equivalent to a brake mean effective pressure of 70 p.s.i. The horse power curve was extended to peak another 1,000-1,500 rpm higher to just on the 21,000 mark, where an output of .485 bhp was recorded.

This is a truly wonderful performance. Only a little less remarkable were the astonishingly cay handling characteristics of the engine. The only thing that needed watching was to have the needle closed down n bit for cold starting, otherwise there was a danger of the engine richening up too rapidly and flooding itself out.

Technique we used was as follows: Open needle 1 1/2 turns. Prime. Start. Engine will start off rich, lean out, then start to surge rich-lean-rich-lean. Open up needle about 1 turn more to smooth out. Hot restarts required no prime, just a flip of the prop.

Running Qualities were equally impressive, especially at the higher speeds, being exceptionally smooth and even. Quit definitely, this is one of the most outstanding model engines, irrespective of type, that we have yet handled.

Summary of Data.

Type: Loop scavenged two cycle with disk rotary valve induction.

Weight: 5 oz.

Displacement: 0.1518 cu.in. or 2.488 c.c. Bore: 0.600 in. Stroke: 0.537 in.

Stroke/Bore Ratio: 0.895 : 1 Specific Output (as tested):

2.63 bhp/cu.in. (1st. test).

3.19 bhp/cu.in. (2nd. test).

Power/Weight Ratio (as tested):

1.28 bhp/lb. (1st. test).