

Fox .15 Logging The Motor Mart

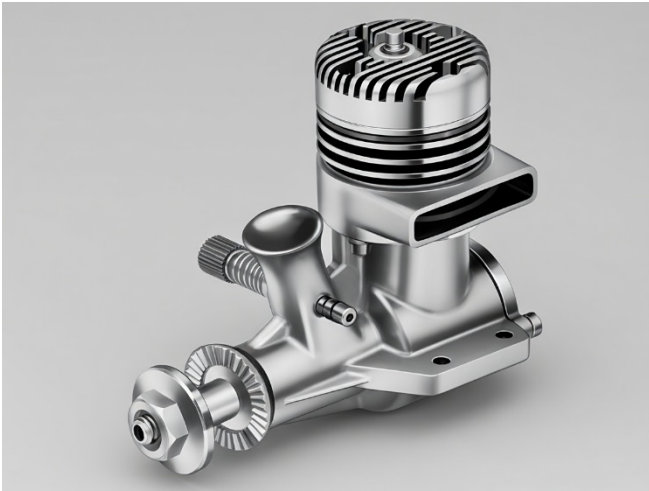

• The Fox .15 is what might be called "A real good engine." It is low in first cost and if the materials used are as good as the larger Fox engines, and they appear to be, the .15 should outwear many models.

The engine handles easily with hot or cold starts and is not easily flooded if one remembers that it is not a through exhaust type engine. Speed adjustment is quite broad and a range of props from 6" through 10" in diameter are handled well. It was noted that the coiled spring to retain the needle valve setting has an interesting action. After creeping up to the maximum r.p.m.'s, by adjusting the needle valve while watching the strobotac, the r.p.m. readings always dropped when we let go of the needle. The spring, it seems, was partly wound up by the needle being turned for adjustment and returned to a slightly rich setting when the finger pressure was removed. The action, of course, is just what should be done before launching a model because the engine will lean out in the air due to the reduced prop load.

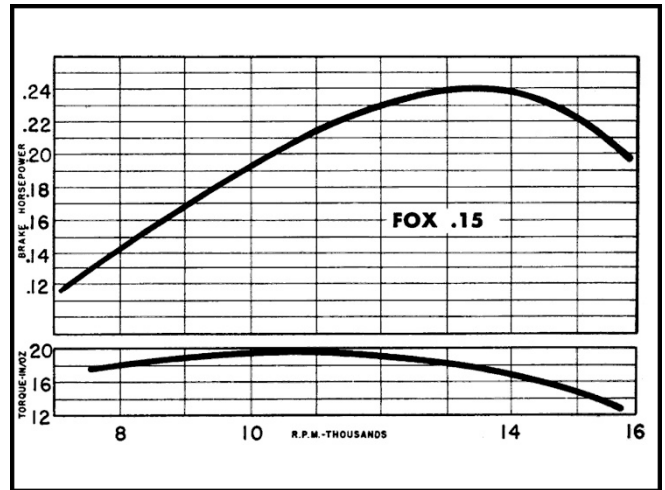
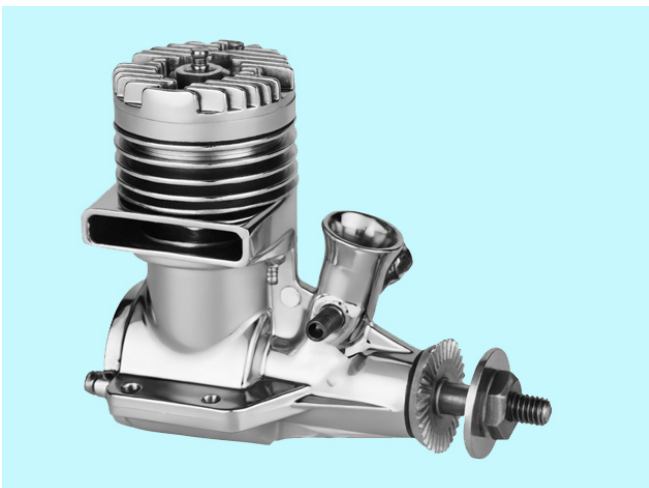

DATA:

Bore: .59"

Stroke: .55

Displacement: .15 cu. ft.

Bore to stroke ratio: 1.07 to 1

Bare weight: 3.8 oz.

Max. torque: 19.6 in. oz. at 11,000 r.p.m.

Max horsepower: .24 at 13,400 r.p.m.

Power rating: 1.6 h.p. per cu. in.

Power to weight ratio: 1.01 h.p. per lb.

Cylinder head: Die cast aluminum, 4 mounting screws
No. 4-48, .010" aluminum gasket

Cylinder: Steel alloy, squared ports, lapped fit with piston

Piston: Melhanite, 1/10" high baffle; flat top
Piston pin: Hardened steel rod, no end pads
Connecting rod: Die cast aluminum

Crankshaft: Hardened steel, counterbalanced, squared port, spline drive, No. 10-32 threads

Crankcase: Die cast aluminum includes 3/8" i.d. bronze bearing, beam mounting lugs, right hand exhaust, venturi intake

Spray bar: Brass, press fit in intake, 2 rings for fuel-line sealing

Prop mounting: 3/16" diameter hole required, No. 10-32 nut

Manufacturer: Fox Manufacturing Co., Fort Smith, Arkansas

Price with glow-plug \$6.95

More: https://flyinghlsat.com/search.php?search_key=words=Fox-Engines