

Fox 15



ENGINE ANALYSIS No. 61

by R. H. Warring

FOX 15

American 2.5 c.c. glow-plug engine rapidly gaining popularity in Britain

The Fox 15 is a beautifully compact 2.5 c.c. glow motor weighing just 4 ounces. Whilst not specified as an out-and-out "performance" engine, it also packs a healthy power output, peaking at nearly .22 B.H.P between 13,000 and 14,000 r.p.m. This, of course, is a static test figure which is always unflattering to glow motors. In the air they appear to have the ability to speed up far more than diesels which is why a static power figure or even a static propeller r.p.m. figure is very rarely a fair comparison between these two types.

The specimen tested had already had some use and was well run in. Main bearing lit was quite slack and there was very little compression when turned over typical of the "ideal" set up for a high revving glow motor. That last comment, in fact, characterised the Fox 15. It is a high speed motor and is not particularly happy either for starting or running at speeds below about 10,000-11,000 r.p.m. Yet its running is steady and sustained well past the peak, up to an 18,000 plus figure achieved on a tiny plastic propeller.

Needle valve control proved somewhat sensitive on the fuel used (Mercury No. 7). The Fox 15 definitely seems to prefer a lean mixture for starting (one, or at the most two. choked turns), and a slightly rich setting for running. Running on a lean mixture it had a tendency to cut abruptly due to a slight change in the fuel supply probably aggravated by the fact that the effective suction lift is quite small. Excessive choking or priming for starting simply produced a "wet" engine which showed no signs of clearing itself.

Apart from this tendency to be slightly critical on needle setting, running was very consistent at all load- speeds above 12,000 r.p.m. Possibly some slight gain in performance could have been realised with a more highly doped fuel (Mercury No. 7 containing only 13 per cent, nitromethane) but could not be expected to come up to top racing performance. But for sport flying and control line work, the Fox 15 is a most useful power plant.

For free flight an 8x4 propeller would appear best; and possibly 7x6 for control line.

Constructionally the Fox 15 features a soft mild steel cylinder machined with integral fins. A substantial flange takes the exhaust port cut-out at one side, and diametrically opposite, the transfer is machined upwards into it in a half-moon shape. The transfer overlaps the exhaust to a considerable degree and opens only very shortly after the exhaust.

The piston is of lightweight form, machined from cast iron, and with a flat deflector offset to the transfer side on the top. The fully-floating gudgeon pin is quite small (only 1/8 in. diameter) and is unhardened while the cast cylinder head incorporates a shaped combustion chamber and attached to the cylinder with four mild steel Phillips head

Fox 15

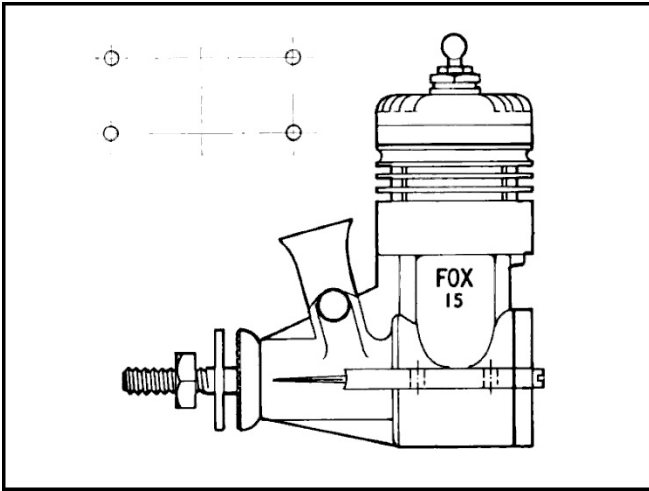

screws. Two of these screws are long and extend down into the crankcase casting to hold the cylinder unit in place and a gasket is fitted for sealing the cylinder flange against the crankcase casting.

Walls of the casting are quite thin, especially in the crankcase bottom itself, but strength appears quite adequate. The main bearing is bushed with a bronze sleeve which is micro-finished to bore size.

The 3/8 in. diameter hardened steel crankshaft steps down sharply to a 3/16 in. diameter threaded length, its intake port is cut square and the crank web is machined away in rather elaborate fashion for weight saving and balance. Crank pin diameter is 5/32 in. (nominal).

A cast propeller driver locates on three splines machined on the crankshaft and butts right against the main section of the shaft. The shaft at this point does appear a little vulnerable, particularly as it is hardened.

Specifications

Technical Data

Displacement: 2.415 c.c. (.147 cu. in.)

Bore: .591 in.

Stroke: .537 in.

Bore/Stroke ratio: 1 : .908

Bare weight: 4 ounces

Max power: .218 B.H.P. at 13,500 r.p.m.

Max torque: 18 ounce-inches at 11,000 r.p.m.

Power rating: .09 B.H.P. per c.c.

Power Weight ratio: .055 B.H.P. per ounce

Material Specification

Cylinder: Mild steel

Piston: Cast iron

Crankcase: Light alloy die casting

Connecting rod: Light alloy die casting

Cylinder head: Light alloy casting

Main bearing: Hardened sleeve

Crankshaft: Hardened steel

Propeller driver: Light alloy casting

Spray-bar: Brass

Back cover: Light alloy die casting

Glow Plug: Standard KLG glow plug used for tests

Manufacturers:

Fox MANUFACTURING COMPANY INC.,
Fort Smith, Arkansas, U.S.A,

Importers:

H. J. NICHOLLS LTD
308 Holloway Road. London, N.7

PROPELLER—R.P.M. FIGURES		
<i>Propeller</i>		
<i>dia. x pitch</i>		<i>r.p.m.</i>
7 x 4 (Frog nylon)		14,250
8 x 4 (Tiger)		13,200
9 x 4 (Trucut)		10,200
8 x 4 (Trucut)		12,800
8 x 3 (Trucut)		13,000
7 x 4 (Trucut)		14,600
7 x 3 (Trucut)		15,800
6 x 3 (Trucut)		16,500
Fuel used: Mercury No. 7		

Prop speeds and Power curve

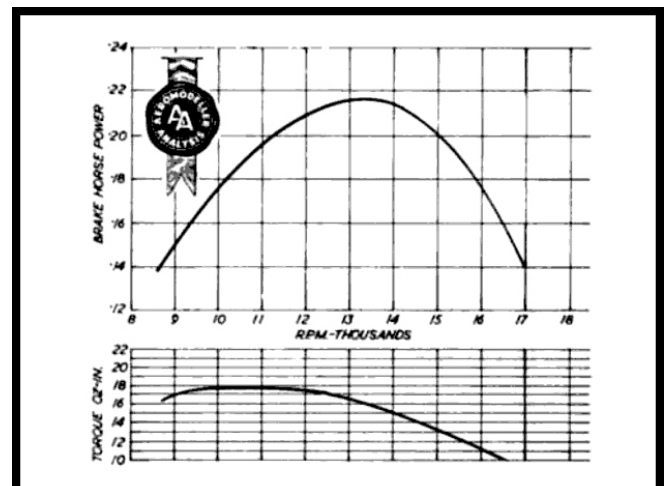

Altogether the workmanship and finish of the Fox 15 is excellent and we have nothing but praise for the way in which both the weight and overall size of the engine has been kept to a minimum, consistent with adequate strength and simplicity of design.