

ENYA 21X-TV

Engine Test

by Peter Chinn

Specification

Type: Single-cylinder, glowplug ignition, Schnuerle-scavenged two-stroke with shaft rotary-valve and side exhaust. Crankshaft supported in two ball bearings. Throttle type carburettor with automatic mixture control.

Bore: 16.6mm (0.6535in.).

Stroke: 16.0mm (0.6299in.).

Swept Volume: 3.463cc (0.2113cu. in.).

Stroke/Bore Ratio: 0.964:1.

Measured Compression Ratio (full stroke): 8.5:1.

Measured Compression Ratio (exhaust closed): 6.3:1.

Checked Weights: 234 grammes — 8.25oz. (less silencer); 286 grammes — 10.1oz (with silencer).

General Structural Data

Pressure diecast aluminium alloy crankcase/front-housing unit with beam mounting lugs and 12mm i.d. intake boss. Detachable diecast aluminium alloy crankcase backplate, secured, with paper

gasket, by four 3mm Allen cap screws. Detachable pressure diecast aluminium alloy cylinder block, aligned with crankcase by cylinder liner and secured, with cylinder-head, by four long 3.5mm Allen cap screws. Joint between cylinder-block and crankcase sealed with paper gasket. Machined aluminium alloy cylinder-liner, 1.85mm wall thickness, with hard-chromed cylinder bore and located by flange at top. Cylinder head of pressure diecast aluminium alloy, with brass thread insert for glowplug, and 0.3mm soft aluminium gasket. Case-hardened steel crankshaft with 12mm dia. main journal, 7mm dia. front journal, 8.3mm bore gas passage and 7mm thick crankweb counterbalanced by means of cutaways each side of integral 7mm dia. solid crankpin. Prop-shaft length threaded M6 x 1.0. NSK-6901 12 x 24mm 10-ball steel-caged rear ball bearing. NSK-607Z 7 x 19 mm 6-ball steel-caged front ball bearing. Machined aluminium alloy prop driver keyed to shaft by two flats on end of front journal. Flat-crowned ringless aluminium

piston machined from special low-expansion, high silicon content aluminium alloy, with rectangular skirt cutaways fore and aft to avoid masking transfer channel entries. Fully-floating 4mm dia. solid gudgeon-pin retained by wire circlips. Forged aluminium alloy connecting rod with bronze bushes and lubrication holes at both ends. Enya G5.5 automatic mixture control type carburettor with machined aluminium alloy body and ground steel throttle barrel. Enya expansion chamber type silencer (optional) with pressure diecast body and pivoted steel cover plate to allow exhaust port priming. Silencer attached to engine with steel strap and two screws.

Test Conditions

Running time prior to test: One hour.

Fuels used: (i) 80 per cent methanol, 20 per cent castor-oil (running-in). (ii) 75 per cent methanol, 20 per cent castor-oil, 5 per cent nitromethane (tests).

Glowplug(s) used: Enya No. 3 platinum-rhodium element.

Silencer used: Enya expansion chamber, as recommended.

Air temperature: 16°C (60°F).

Barometric pressure: 758mm (29.8in.) Hg.

Relative humidity: 78 per cent.

Test Results

Power output, gross: 0.57bhp at 18,500rpm.

Power output, net: 0.49bhp at 16,300rpm.

Torque, gross: 36oz. in. at 11,000rpm.

Equivalent b.m.e.p.: 67lb/sq. in.

Specific output, gross: 165bhp/litre.

Specific output, net: 141bhp/litre.

Power/weight ratio, gross: 1.10bhp/lb.

Power/weight ratio, net: 0.78bhp/lb.

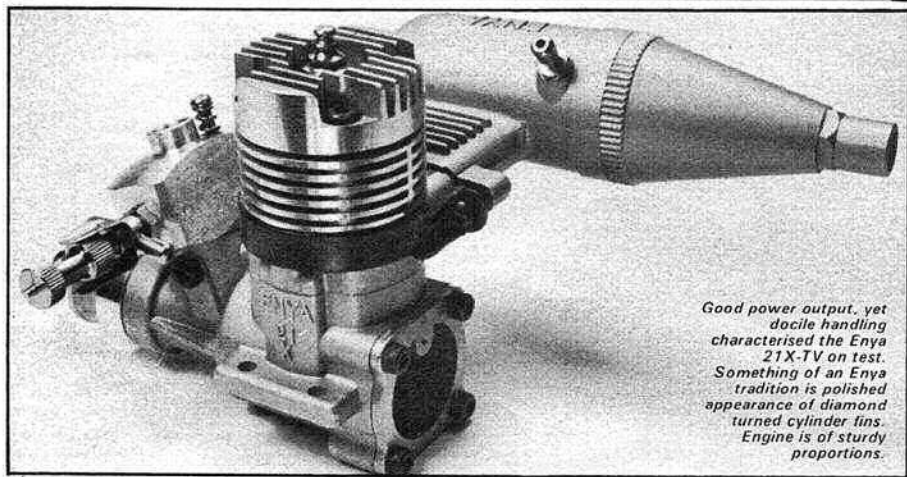

Good power output, yet docile handling characterised the Enya 21X-TV on test. Something of an Enya tradition is polished appearance of diamond turned cylinder fins. Engine is of sturdy proportions.

FEW COMPANIES can have had so much experience in producing glowplug engines in the .20cu. in. or 3.5cc classes as the Enya Metal Products Company Ltd., of Tokyo. It was in the late 1940s that the Enya brothers began making model aircraft engines, initially the robust 10cc class Enya '60' and '63', then, in 1950, the first of a long line of Enya '19' models. Currently, the Enya range is one of the world's largest. It comprises no less than 43 throttle-equipped models, ranging from 0.8cc to 10cc, some of which are also available in standard non-throttle control-line or free-flight versions and/or in water-cooled marine units. Included in the range are three basic '19' models (plain bearing and ball bearing crossflow scavenged, plus a ball-bearing Schnuerle-scavenged unit)

ENYA 21X-TV FULL-SIZE

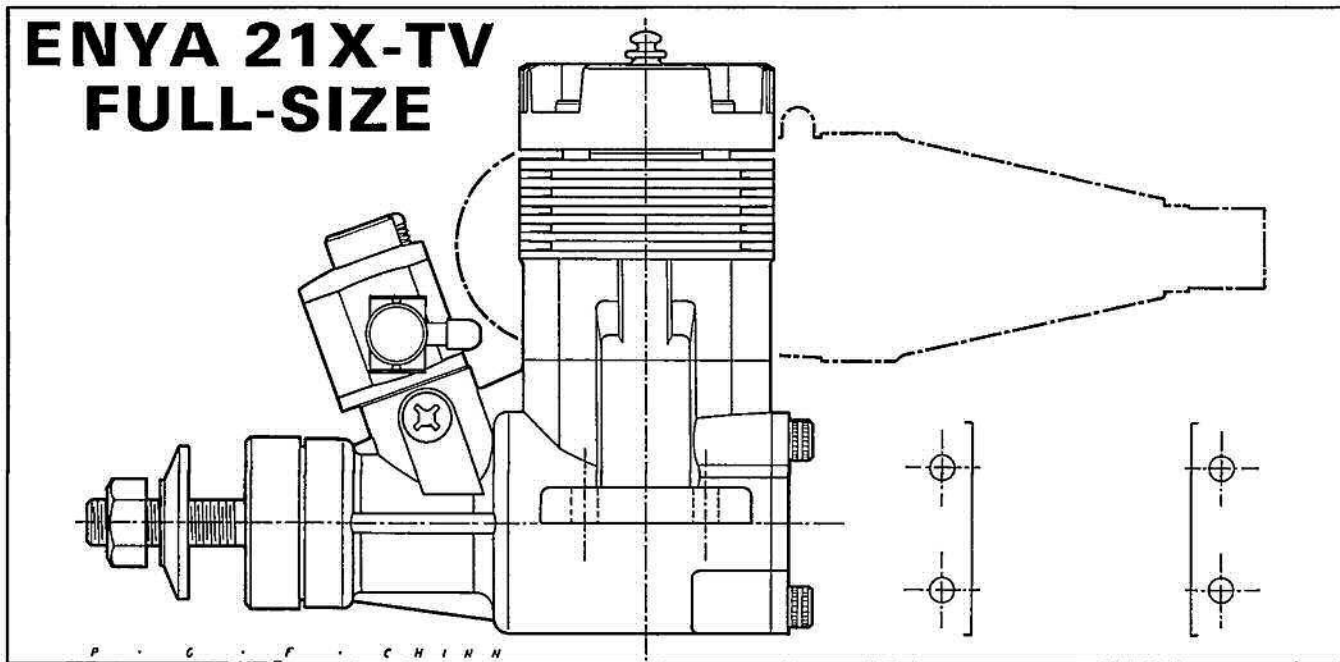

and seven '21' models and it is the standard 21X-TV version of this group that is the subject of our report this month.

Like all the 'X' series Enya engines (the 'X' identifies them as modern Schnuerle-scavenged designs) the 21X-TV is a well-built and nicely finished engine. In addition to having a twin ball bearing crankshaft and Schnuerle porting, it features an 'Al-Chrome' piston/cylinder assembly: that is to say, it uses a ringless aluminium piston running in an aluminium cylinder liner having a hard-chrome plated bore. This, like a ringless piston in a chromed brass liner (ABC), combines the advantages of a light piston, a cylinder sleeve whose thermal expansion is closely matched to that of the piston, thereby maintaining good piston seal without risk of seizure over a wide temperature range and, finally, giving better heat conductivity to the surrounding

metal of the cylinder block.

The cylinder-block is, in fact, another unusual feature of the 21X in that it is separate from the crankcase proper. The channels for the three transfer ports are cleanly cast into the two components which are then aligned by the cylinder sleeve, the whole assembly, with cylinder head, being clamped together with four long cap head screws. The cylinder porting consists of an unbridged exhaust port, flanked, each side, by a transfer port that is angled to direct gas both away from the exhaust and slightly upward, with, diametrically opposite, a third port inclined sharply upward to carry the charge well up into the combustion chamber. The exhaust is timed to remain open for approximately 150 degrees of crank angle, while the main transfers are open for 128 deg. and the third port for 122 deg. As is usual with

ringless piston engines, the cylinder bore is tapered slightly towards the top to improve piston seal. The actual reduction in bore is of the order of 0.001in. The cylinder head has a shallow (2.6mm deep) bowl shaped combustion chamber surrounded by a 2.5mm wide annular squish area.

In common with most other current .21cu. in. motors, the 21X has a 12mm crankshaft running in twin ball bearings. It has a rectangular valve port, 13mm long, which uncovers a parallel sided intake port for 195 degrees of shaft rotation. Nominal timing is 35 degrees ABDC to 50 degrees ATDC.

The 21X-TV is fitted with an Enya G5.5 carburettor. This is of the fixed automatic mixture control type. From a conventional needle-valve assembly, fuel enters the carburettor body and then, via a short internal transfer channel and a tapered groove on the surface of the throttle barrel, is admitted to the fixed jet tube within the barrel. The tapered groove meters the quantity of fuel relative to the amount of air admitted at different throttle openings. This takes care of mixture strength at part-

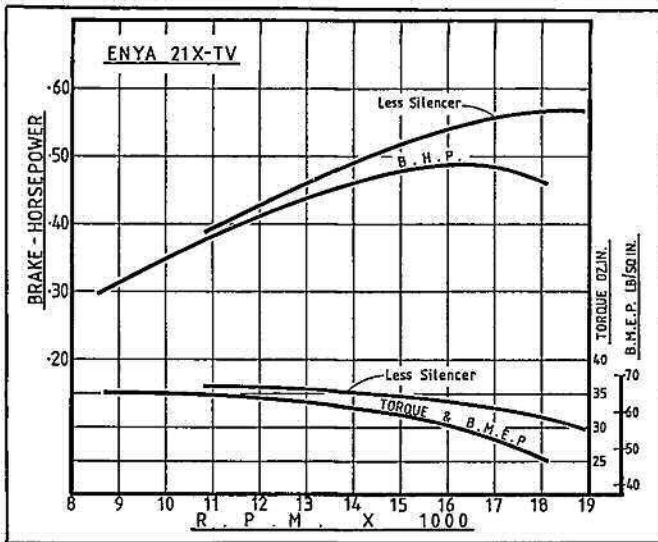

Below: slightly unconventional use of separate cylinder block. Note transfer channels.

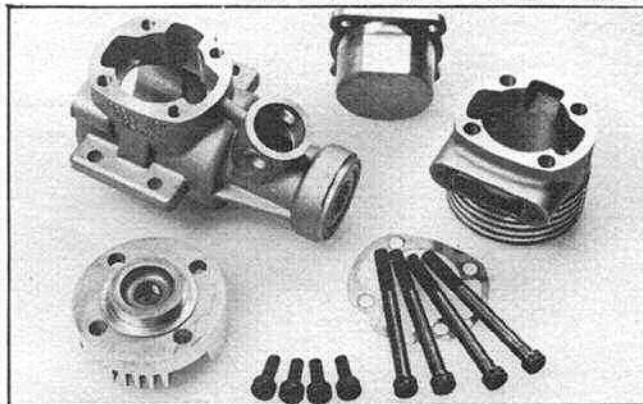

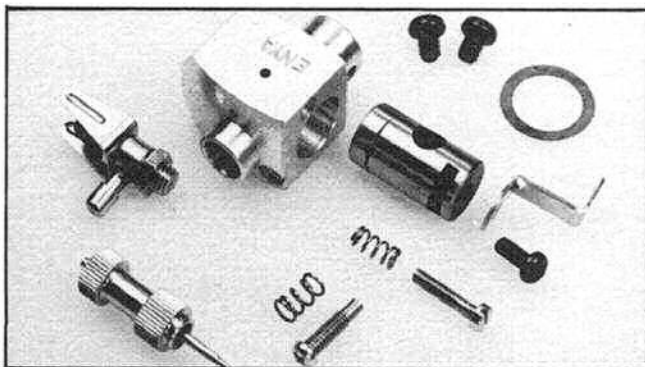

Above: parts of Enya G5.5 carburettor. Tapered groove, on surface of throttle barrel, meters fuel according to throttle opening. Right: silencer is of simple expansion chamber type. Carburettor incorporates fixed automatic fuel metering, plus adjustable air-bleed.

throttle settings. For fine-tuning the idle mixture, a separate airbled adjustment is provided.

The carburettor has a 5.5mm i.d. choke and an effective area of 18 sq.mm.

The silencer for the 21X-TV is of typical Enya design and is of the non-baffled expansion chamber type, with a pivoted cover which permits exhaust port priming to assist cold starting. The silencer has a volume of 40ml and its 7.6mm i.d. outlet nozzle gives a fairly generous outlet area of 45sq. mm. A nipple is fitted to the silencer for pressurising the fuel tank where assisted fuel delivery may be desirable.

Performance

As an indication of the type of fuel best suited to the Enya 21X, the manufacturer lists three simple mixtures, each based on a 20 per cent lubricant content: the first a straight blend of methanol and castor-oil; the second containing 5 per cent nitromethane and the third containing 10-20 per cent nitromethane. Our motor was run-in on the straight mix, after which all tests were carried out on the 5 per cent nitro blend as this is similar to the standard fuel used for most of our tests of two-stroke R/C engines. Typical commercial equivalents are Model Technics GN-5 and GX-5. The glowplug (not supplied) used for all tests was the Enya No. 3.

From the very beginning, the Enya 21X was found to be a pleasant engine to handle. It started instantly with an electric

starter, was docile when being hand started and ran smoothly and evenly on a wide variety of props. Some engines having ringless pistons in chromed non-ferrous cylinder liners can be more difficult to hand start from cold, when new, due to excessive tightness in the piston/cylinder fit at the top of the stroke. This was certainly not so with the 21X which plopped over TDC smoothly and started easily by hand, when cold, from the very beginning. Hot restarts were usually obtained with a single flick of the prop. Only when the engine had cooled down, but was still warm enough to reduce compression seal and needed to be primed, did hand starting become less positive. Quicker response was then obtained by applying an electric starter.

Being quite free, even when new, the Enya obviously needed little running-in and, from an early stage, showed none of the tendency, frequently encountered in other engines, to lose power as it warmed up from cold. Typical prop rpm readings obtained on 5 per cent nitro fuel, without the silencer fitted, included 9,400 on a 10x6 Top Flite maple, 10,000 on a 10x5 Top Flite maple, 11,000 on a 9x6 Power Prop maple, 11,600 on a 9x5 Zinger maple, 11,600 on a 10x4 Top Flite maple, 12,300 on a 9x4 Top Flite maple, 13,500 on a 9x4 Zinger maple, 14,200 on a 9x4 Power Prop maple, 15,000 on an 8x5 Zinger maple, 15,800 on an 8.5x4 Zinger and 16,300 on an 8x5 Power Prop maple.

On test, a maximum torque of 36oz. in. was

recorded. The torque curve was relatively flat, as a result of which, maximum power was reached at high rpm (between 18,000 and 19,000) where a gross output (i.e. less silencer) of 0.57bhp was determined. This is a very good figure for a 3.5cc engine fitted with a standard R/C carburettor and running on mild fuel, but the 21X is perfectly happy on higher nitro content mixtures and, where the user wishes to boost output, 20 or 30 per cent nitromethane can be expected to raise peak output well beyond 60bhp, along with an improvement in torque for increased performance on the more useful prop sizes.

Fitting the silencer did not cause excessive power loss on the sort of props that most owners would be likely to use. On 10x4 and 9x5 props, for example, the rpm loss (static) was of the order of 200-300. Under much lighter loads (e.g. 8x5) aimed at getting the engine up to its bhp peak, losses are somewhat greater, but unless one is thinking in terms of a very small, fast aeroplane, we have to call into question prop efficiency and whether it is not better to forgo peak power in the interests of the possibly greater thrust of a larger prop turning more slowly. For the majority of models using an engine of this type, a 9, or even 10 in. dia. prop will probably be the most appropriate.

As the performance curves show, fitting the silencer did not have a very great effect on maximum torque, but the torque curve fell off more sharply as load was reduced, resulting, finally, in a maximum power output of just under 0.5bhp at approximately 16,300rpm.

Controls were good. The needle-valve was just about right as regards sensitivity, while the response to the throttle was equally satisfactory. Safe, continuous idling at 2,600rpm was obtained on a 10x4 prop.

In all, a very pleasing motor.

Manufacturer: Enya Metal Products Co. Ltd., Nerimaku, Tokyo, Japan.

U.K. Distributor: Ripmax Ltd., Ripmax Corner, Green Street, Enfield EN3 7SJ.

U.K. Service: John D. Haytree, The Haven, Rixey Park, Chudleigh, Newton Abbot, Devon TQ14 0AN.

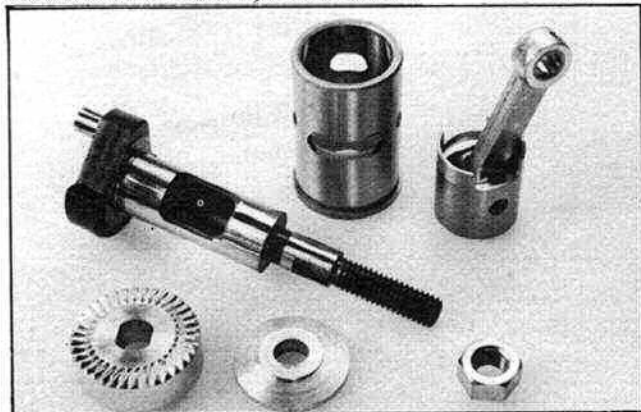
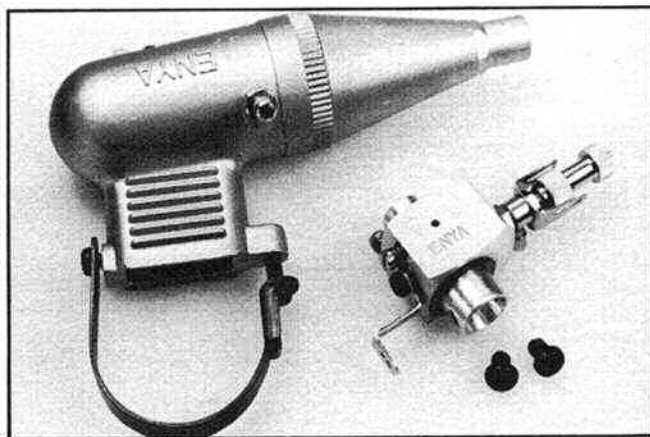

Crankshaft is orthodox; cylinder liner, of chromed aluminium alloy, is not. Note: hefty forged conrod.