

**THE**



# ENYA 15-1B

## 2.5 c.c. GLOWPLUG MOTOR

*"... on a par with the best in the 2.5 c.c. Glowplug class ..."*

**T**HE original model 2.5 c.c. glowplug Enya 15 was introduced early in 1955 and production continued through 1956. We had one of these engines on test last year. It was a delightful little motor, exceptionally easy starting and possessing those silky, smooth-firing qualities which, difficult to put on paper, nevertheless make the tester's life so much more pleasant than do the harsh-running, erratic and unpredictable characteristics of some engines which pass through our hands.

This earlier test revealed an output

of 0.25 b.h.p. at 13,800 r.p.m., using 25 per cent nitromethane in the fuel, but with the detachable choke insert retained; a figure which, until recently, would have justified the Enya's inclusion in the upper performance group of 2.5 c.c. engines. In order to compete with the best in the highly-competitive International class, however, it was evident that a small increase in output would be necessary and, towards the end of 1956, the manufacturers succeeded in doing this by introducing some minor modifications into the design.

These consist of a raised compression cylinder-head of slightly changed form, a slightly enlarged crankshaft port, a fractionally lighter piston and a reduced diameter spraybar. In addition the crankshaft and front-bearing assembly has been lightened by reducing the journal length by 2 mm. and by taking the gas passage a further 4 mm. forward into the shaft so that the complete engine is also fractionally lighter.

This revised model was put into production in January of this year and was initially known as the 15-1S, which designation, however, was later changed to 15-1B. Apart from the almost imperceptible reduction in front bearing length, there are no external

changes and the only way in which the 15-1B can be readily distinguished from its earlier brother is in its use of Phillips screws, on the cylinder-head and crankcase flange, in place of the ordinary cheese-head screws used previously.

So far as performance is concerned, the peak b.h.p. has been raised quite appreciably, sufficient in fact, to place the Enya 15-1B in the front rank of 2.5 c.c. production glowplug engines.

Enya engines are, of course, of Japanese manufacture. They have enjoyed an excellent reputation for many years in Japan and also in the few countries to which they have been exported, mainly on account of their sound construction, easy handling and useful performance. During the past year or so, however, the manufacturers have obviously been turning their attention to ultra-high performance and their success here has been most noticeable in the 2.5 c.c. Enya 15-D diesel, and in the 5 c.c. Mk. III model 29.

Like all the current Enya glowplug models, the 15-1B is a loop-scavenged, shaft-valve engine, having the crankcase and cylinder barrel in a single pressure diecast unit, with pressed-in liner. The casting is of good quality, sandblasted and with machined edges to give a pleasing matt grey and polished aluminium finish.

### Specification

Type: Single-cylinder, air-cooled, loop-scavenged two-stroke cycle glow-

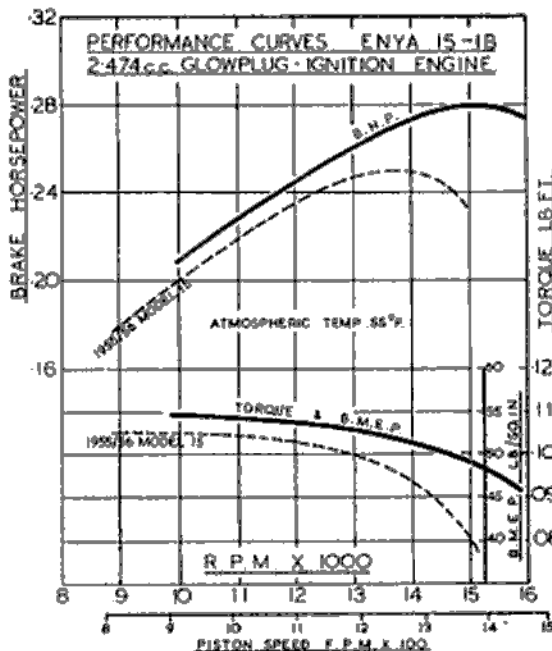

plug ignition. Induction by crankshaft type rotary valve. Centrally located plug.

Swept Volume: 2.474 c.c. (0.151 cu. in.).

Bore: 15 mm. (0.5905 in.). Stroke: 14 mm. (0.5512 in.).

Stroke/Bore Ratio: 0.933 : 1.

Weight: 4.2 oz.

#### General Structural Data

Pressure diecast aluminium alloy crankcase and cylinder barrel with inserted cast-iron cylinder liner. Pressure die-cast aluminium alloy front housing with integral venturi intake and bronze main bearing. Balanced crankshaft with 9 mm. (0.354 in.) dia. journal and 5 mm. (0.197 in.) dia. crankpin.  $10 \times 7$  mm. rectangular shaft valve port and 6.5 mm. (0.256 in.) dia. gas passage. Lapped lightweight piston with straight fence baffle and 4 mm. (0.157 in.) full-floating gudgeon-pin having aluminium end-pads. Alloy connecting-rod with bronze big-end bush. Deeply finned aluminium alloy cylinder head having cast-in threaded bush for glowplug, and attached to main casting with four screws, with metal-to-metal joint. Alloy prop driver fitted to matching taper on shaft. Nickel-plated brass spraybar type needle-valve assembly with flexible needle-valve stem and detachable venturi insert. Beam mounting lugs, also provision for installing three radial mounting studs in rear of crankcase.

#### Test Engine Data

Running time prior to test:  $1\frac{1}{2}$  hours.

Fuel used: 25 per cent. B.D.H. nitromethane, 50 per cent. I.C.I. blending methanol, 25 per cent. Duckham's racing castor-oil.

Ignition plug used: Enya No. 1 standard 2-volt Ni. Cr. glowplug. 2.1 volts used to start. Venturi insert retained for all tests.

#### Performance

The 15-1B is, perhaps, just a trifle less foolproof than the original type Enya 15. It is still an easy starting engine, but responds less readily to the more "clueless" type of handling that its predecessor seemed to take in its stride. As the engine is intended for the competition minded user rather than the raw beginner, however, this can scarcely be taken as a criticism and, in this event, is a small price to pay for the extra performance available.

As was expected, the improved

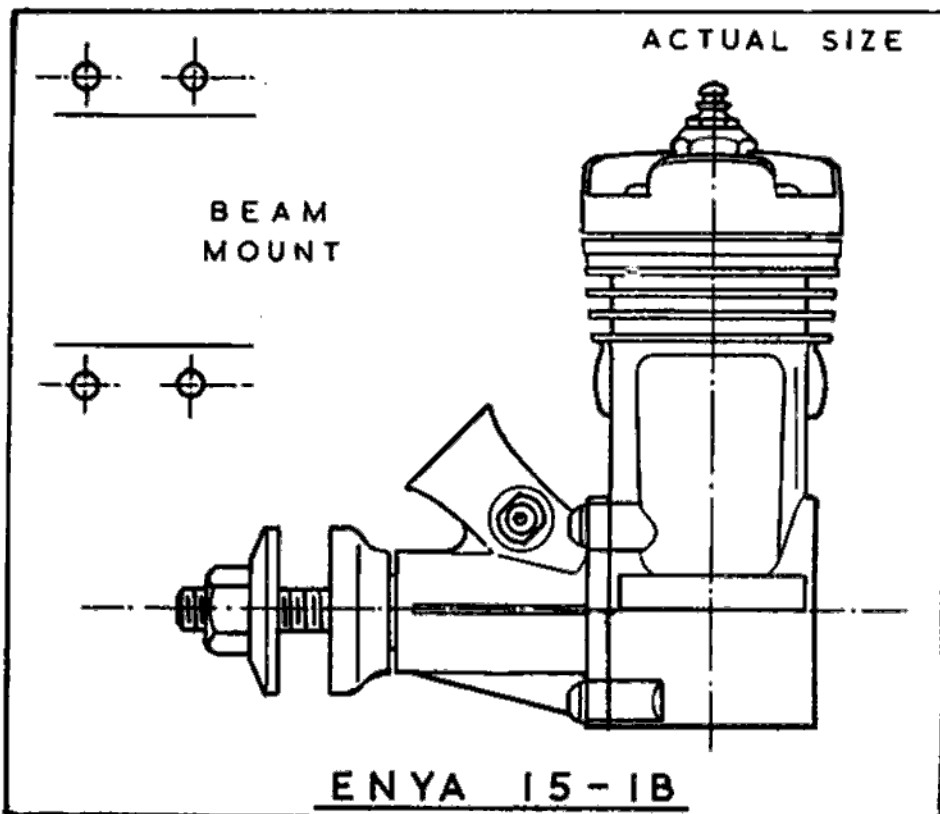

output of the 15-1B became increasingly evident as load was reduced and r.p.m. raised. At 12,000 r.p.m., torque was up approximately 5 per cent; at 13,000 r.p.m. approximately 7 per cent; at 14,000, 10 per cent. and at 15,000, 22 per cent. Maximum b.m.e.p., which was reached at around 10,000 r.p.m., was just under 55 lb./sq. in. which is a good figure for engines of this type.

The peaking speed of the 15-1B, as compared with the earlier 15, has been raised by more than 1,000 r.p.m. to a little over 15,000. Here, we recorded an output of 0.28 b.h.p. which, it will be observed, is on a par with the best that we have thus far obtained in the 2.5 c.c. glow engine class.

This, it will be noted, followed a running-in period of  $1\frac{1}{2}$  hours and was obtained with a nitromethane content of 25 per cent., a standard nickel-chromium element plug and

with the venturi restrictor in position. We are informed by the makers that their own dynamometer tests have indicated that an output of nearly 0.30 b.h.p. can be obtained with these engines in stock condition after adequate running-in and that approximately 0.31 b.h.p. at 16,000 r.p.m. has been reached with the venturi insert removed. Having found that factory claims concerning at least two other Enya engines were more than substantiated by our own tests, we have no reason to doubt that, under reasonably favourable atmospheric conditions and with some extra running, our test model would, in fact, more closely approach these figures. It may be mentioned, in passing, that Enya makes five different types of glowplugs to enable the best choice to be made for any given conditions. These include two standard 2-volt nickel-chromium plugs and three  $1\frac{1}{2}$ -volt racing plugs with platinum-rhodium filaments.

The 15-1B ran evenly at all speeds tested. It was fairly sensitive to the needle-valve but adjustment of the control was helped by the sensible design of the needle-valve assembly with its large knurled adjusting knob, flexible stem and effective ratchet device.

Power/Weight Ratio (as tested): 1.07 b.h.p./lb.

Specific Output (as tested): 113 b.h.p./litre.

