

so it will loosen most easily. Too much pressure against the exhaust ports so hold the cylinder from turning may force the cylinder out of round or even turn a burr into the bore. A new cylinder is usually required to remedy such damage.

7. To remove the glow head from a hot engine—pour a little fuel slowly over the glow head to reduce the head temperature. Do not run it over the cylinder. The head will then release easily. A hot head will stick and forced removal may damage the cylinder.

8. Do not tighten the carburetor retainer nut more than enough to hold the carburetor body from rattling. Overtightening will distort the front bearing and cause power drop and inconsistent running.

9. Tighten the venturi nut only enough to hold needle valve body in position. Overtightening may strip the thread from the plastic carburetor body.

10. The needle valve body may be removed and replaced in the opposite position if desired.

(E) PRESSURIZING

Pressurizing is very critical when taken directly off the crankcase. On this engine pressurizing means have been provided and the rotary valve controls the pressure to normal operating limits. To rig up for pressure the crankshaft must be removed. The hose connector on the side of the carburetor body is located exactly over the spot where the pressure is taken off. The metal pads are not drilled however, and a drill at the correct size to fit the rose connector or slightly smaller must be used to continue this hole through the metal parts. The burr must then be carefully removed from the interior of the bearing and the engine reassembled. The hose connector is then connected to the tank with a piece of plastic fuel tubing.

With pressure, the venturi may be opened to 1/8" on the .049 or 3/16" on the .15 engine to attain maximum power although the gain is very little.

SPECIFICATIONS

	TEE DEE .049	TEE DEE .15
Weight	1.48 oz.	4.04 oz.
Bore	.406"	.585"
Stroke	.386"	.556"
Displacement	.0499 Cu. In. 819 cc	.1494 Cu. In. 2.449 cc
Overall Height	1-31/32"	2-3/4"
Height Above Rails	1-5/8"	2-9/32"
Overall Length	1-11/16"	2-1/2"
Width	1-1/8"	1-7/16"
Center to Center Width of Rail Mounting Holes	15/16"	1-1/4"

WARRANTY

This engine is guaranteed against defects in materials and workmanship for 30 days from date of purchase. Glow heads are never guaranteed because of their delicate nature. No other guarantee is made or implied. If engine is returned to the factory within warranty, include 50c to cover cost of handling and return postage.

Do not take engine back to your dealer.

SPEEDS

The following speeds are typical of engines selected at random and run under average conditions:

TEE DEE .15		TEE DEE .049	
Prop Size	RPM	Prop Size	RPM
7" Dia. x 4 P	19,850	5" Dia x 3 P	23,000
8" Dia. x 3 P	18,050	5 1/2" Dia x 4 P	18,500
8" Dia. x 4 P	15,700	6" Dia x 3 P	18,500
9" Dia. x 3 P	14,750		

FACTORY REPAIR SERVICE

Minor repairs, examinations, at adjustments—\$1.50 plus parts. Complete overhaul guaranteed new engine performance .049—\$4.75, .15—\$7.50, including parts. On all C.O.D. shipments, purchaser pays postage and C.O.D. fees.

PARTS ORDER

Purchase parts from your dealer. If not available, order direct from factory. No C.O.D.'s please. Send remittance with your order. On orders less than \$2.00 add 35c handling charge. In California add 4% sales tax.

Prices and design of parts subject to change without notice.

PARTS LIST

	TEE DEE .049		TEE DEE .15	
	Cat. No.	List Price	Cat. No.	List Price
Crankcase	1701	1.50	1801	2.40
Glow Head	1702	.65	1802	.75
Piston & Rod Assy.	303	1.50	1103	1.75
Cylinder	1704	1.50	1404	1.75
Crankshaft	1705	2.25	1805	3.00
Needle Valve & Spring	1709	.60	1809	.75
Prop Drive Plate	1710	.20	1810	.25
Venturi	1717	.60	1817	.85
Prop Spinner & Screw	1718	.30	1418	.40
Retainer Nut	1721	.25	1821	.35
Crankcase Rear Cover	1722	.35	1822	.40
Thrust Washer	1723	.10	1823	.15
Carburetor Body	1724	.60	1824	.70
Carburetor Complete	1725	2.50	1825	3.00
Needle Valve Body	1726	.60	1826	.85
Engine Mount	1560	.50	—	—
Wrench	1530	.25	1130	.35

Order Part. by Catalogue Number

L. M. COX MANUFACTURING CO.
730 Poinsettia P.O. Box 476 Santa Ana, Calif.

Printed In U.S.A. 2-61 1759

CARE AND OPERATION OF YOUR COX TEE DEE .15 AND TEE DEE .049 ENGINES

THIS ENGINE IS A VERY HIGHLY PRECISE CONTEST-TYPE ENGINE

Keep it immaculately clean, use Thimble Drome Racing Fuel in its red can and it will maintain its winning characteristics for a long period of time.

This engine is precisely fitted at the factory for immediate, easy starting and is ready for flight. A break-in period in the ordinary sense is not necessary for flight, in fact, a slow, easy break-in is not desirable. Most of these engines will develop almost full power within one minute of running time but a few, those which are slightly on the tight side, may not develop full power under one hour. Even these will develop sufficient power for average flying almost immediately. The only break-in required is very rich (stow) running for the first 60 seconds after starting the first time. After 60 seconds it should be ready to go. 30 minutes running time will add a few RPM for peak contest operation.

Elimination of break-in is not attained through loose or sloppy fitting, but through very precise fitting, together with super fine wearing surfaces.

Remember—your Tee Dee engine is much happier at high speeds. Let it wind up. Do not use oversize props.

(A) PREPARATION FOR RUNNING

1. Mount the engine in the plane, or if you want to give it same running first, mount it on a suitable mount. Do not hold the engine directly in a vise. Use A-Fig. 1, or A-Fig. 2 as a template to drill mounting holes.

2. Place propeller on the shaft with the flat side of the blades toward engine and lock securely with the propeller screw.

3. Use a Thimble Drome filler spout with stainless steel strainer in your fuel can. Your engine will thus be filled direct from the can and protected from dirt and foreign matter that would otherwise stop up the carburetor jet. The strainer keeps dirt out of the can, and any particles that might already be in the can, from getting into the carburetor jet.

4. Procure a 1 1/2 volt dry cell battery, #6 or equivalent, and connect it with 2 flexible insulated wires to the glow plug clip as shown in the diagram A and B-Fig. 3. Do not use a stronger battery. If you do, the plug will burn out. The connections should be soldered to insure good contact, and taped to prevent bare ends of wire from getting together and shorting the battery. Be sure the battery is a good one. Your dealer sells batteries and glow plug clips. The Thimble Drome plastic mounted glow plug clip with wires already attached is recommended, and requires no soldering. (Cat. #755—35c).

5. Balance and trim propeller. This is very essential for good performance. Sand off any bead of plastic along

the edges of the blades. Fit a drill or shaft through the hole and rest the shaft on razor blades set in wooden blocks as shown in C-Fig. 3. Sand the heavy blade until the propeller will balance in a horizontal position. Care must be taken to do the sanding without spoiling the airfoil characteristics of the propeller blades. Caution: use only nylon or wooden props. Styrene props are extremely dangerous on these engines.

(B) STARTING THE TEE DEE ENGINES

No matter how expert you are with small engines you will have better luck with these engines if you follow directions exactly as listed and do each operation in the exact order given.

1. Close the carburetor needle valve, B-Fig. 1, or B-Fig. 2, by turning it clockwise until it stops. Do not force it.

2. Fill the fuel tank with Thimble-Drome racing fuel (in the red can).

3. Open the needle valve counter clockwise exactly 4 turns for the .049, or 3 1/2 turns for the .15 engine.

4. If the fuel level in the tank is lower than the carburetor venturi, put your finger over the air intake of the engine and pull the prop thru compression until the fuel hose is full. Use a clear plastic fuel line so this can be checked visually. If the tank is mounted so the fuel level is higher than the carburetor the hose will fill itself when the needle valve is opened.

5. Connect the battery by snapping she clip on the glow head B-Fig. 3.

6. Squirt a few drops of fuel into the exhaust ports and immediately flip the propeller over counter clockwise. For quick starting the propeller must be flipped quite vigorously. The engine should start instantly if it has been primed with the correct amount of fuel in the exhaust port.

7. When the engine starts it will be running very rich and slow. The first time the engine is started let it continue to run rich for a period of 60 seconds. After approximately 60 seconds, slowly close the needle valve clockwise to the best running position and remove the battery connection. Subsequent starts may be adjusted to best running position immediately.

8. If starting is delayed for any reason, close needle valve, otherwise engine will become flooded. This precaution is only necessary if be tank is mounted or the fuel level is higher than the carburetor.

(C) FAILURE TO START

1. If the engine coughs and spits a bit of fuel spray from the exhaust, it is too rich. Close the needle valve and continue cranking until engine starts briefly. Open the needle valve again and crank it over, it should start immediately. Blowing into the exhaust ports between flips will help clear the excess fuel out of the glow plug.

2. If it starts up with lots of power and dies immediately it is too lean. Open the needle valve a half turn, prime the engine, and crank it over again. If the trouble persists and the tank is lower than the carburetor try choking again as in Section B Par. 4. If the engine hasn't been run for some time it is possible that thick castor oil is clogging the jets. Choking will clean this out.

FULL SCALE VIEWS OF THE TEE DEE .049
FOR INSTALLATION INFORMATION

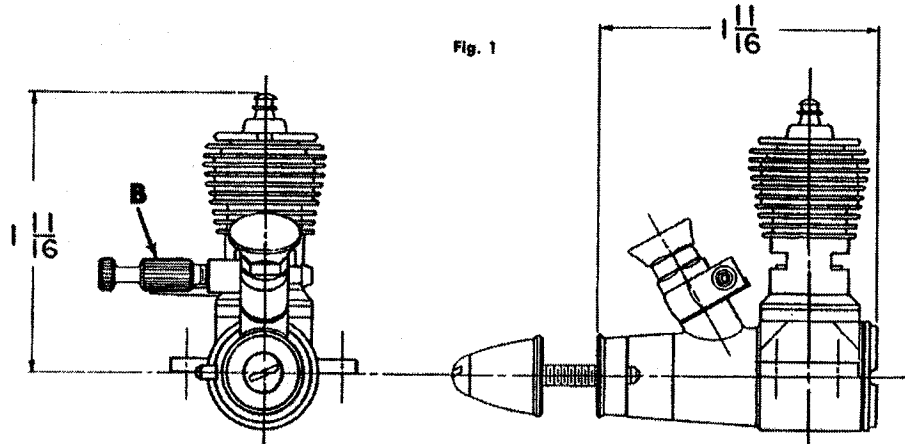
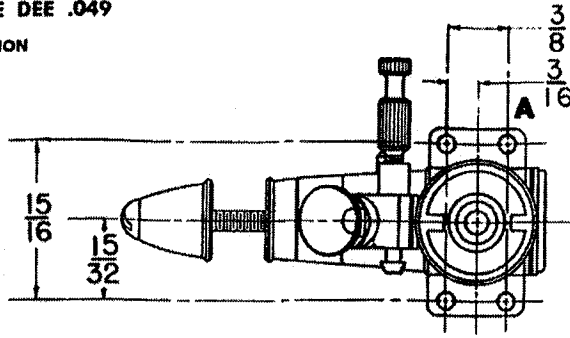

Fig. 1

(D) OPERATING TIPS AND ENGINE CARE

3. If the engine still persists in above action it is possible the carburetor jets are stopped up. Remove the venturi nut and needle valve body. Three tiny jet holes will be found in the groove around the venturi tube. Clean these jet holes with a piece of fine wire. Reassemble and the engine should run.

4. If the engine refuses to fire or at all screw the glow plug out and connect it to the clip. If the little coil inside does not get red hot, it is either burnt out or the battery is dead, or the connections are made incorrectly. Replace the battery or the plug, or, correct the connections. Glow plugs are never guaranteed. Do not return the engine to the factory for a burnt out glow plug because the cost to you will be excessive. Buy one from your dealer.

5. If you are not using Thimble-Drome fuel, try it. **Never use gasoline or gasoline type fuels.**

1. The glow plug is built right into the head in one unit. When the plug burns out just replace the entire head at the regular glow plug price.
2. After the last run, oil the engine with a light oil (SAE 10 is good) and wrap it with cloth or otherwise protect it from dust and dirt.
3. If the engine gets dirt in it through crack-up or otherwise, do not run it until it is thoroughly cleaned. Take it apart, wash it, oil it, and reassemble.
4. If the engine gets tight it is not frozen up. Do not send to factory. A new engine will sometimes tighten up a few times, especially after slow runs. This is more likely to happen, and will occur more often to an engine that is properly fitted, and has properly smooth wearing surfaces. Do not run it tight. The lightness is caused by a

FULL SCALE VIEWS OF THE TEE DEE .15
FOR INSTALLATION INFORMATION

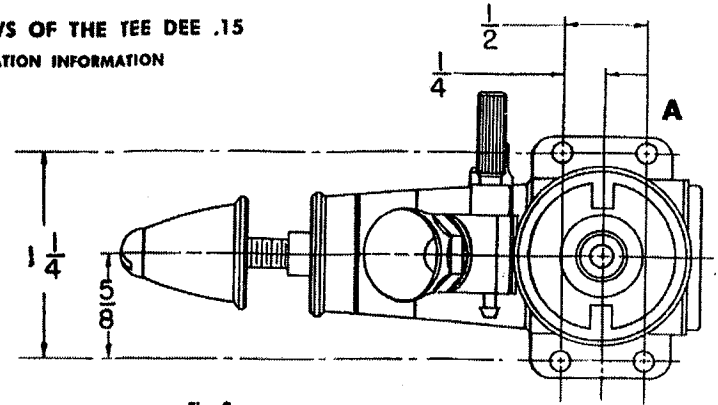
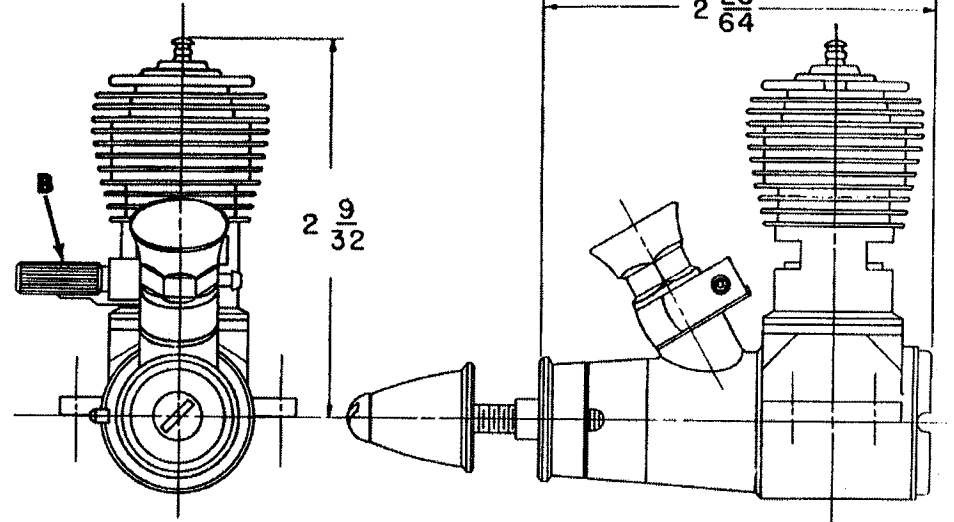

Fig. 2



shellac-like deposit on the cylinder wall. Screw the head off. Remove the cylinder and scour the inside wall very lightly with a bit of fine or medium steel wool. Wash, oil, and replace. The engine will then turn over freely and run properly. Never use sandpaper, emery cloth, or abrasives of any kind, or scrapers. Such methods will ruin the cylinder. Steel wool will not harm the bore.

5. Certain kinds of weather, especially warm humid sticky weather will cause excessive shellacking in a new cylinder. There is no known way to eliminate this nuisance and the smoother the fit the more susceptible is the engine to this trouble.

6. Do not tighten the head too firmly. Set it up very lightly. Allow the engine to cool before removing head

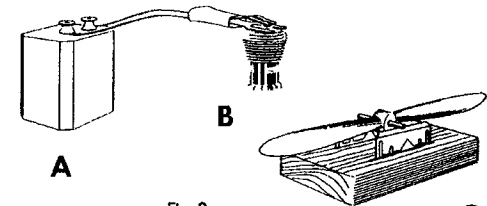

Fig. 3