

# Cox Olympic .15

By

ENGINE ANALYSIS No. 65



By R. H. Warring.

The New Cox "Olympic" must be the complete answer to any European modeller who maintains that no production glow motor under 3.5 c.c. can hope to compete with a top class diesel for power output. Developing a peak B.H.P. figure, on test, of almost .29 at 16,500 performance over the whole of the speed range has the edge over the top "racing" diesels. In free flight, in particular, this superiority should be even more stressed by the smoother running, absence of vibration and greater speed up in the air. Only in team racing will its greater fuel consumption put it at a disadvantage.

The "Olympic", we are told, has been some three or four years in development. In point of fact, it has turned out to be a typical "Cox" design, featuring the same layout and porting arrangement as on the smaller Cox engines. Similarly, every component is machined from bar stock, there being no castings used, with the greater majority of the production work carried out on fully-automatic machines, so that the finished product, although not "untouched by hand", has far less manual labour associated with it than any British counterpart. All major machining operations, too, are carried out under temperature (and humidity) controlled conditions to ensure maximum geometric accuracy.

The result is a relatively simple design, beautifully and accurately made and with all running fits and clearances just right. The Cox is ready to run fast

"as made", extremely easy to handle and very consistent in performance.

Induction is via the now familiar Cox type reed valve, mounted on the rear of the crankcase. Induction timing is thus automatically controlled by the "breathing" of the engine. Exhaust timing is conventional, but the transfer almost fully overlaps the exhaust. There is also a measure of sub-piston induction (which is the reason why the bottom of the exhaust ports come below the top of the piston at B.D.C.). The fuel entry is a little unusual (although again typically a Cox idea) in that the actual needle valve is mounted to one side of the induction lube, feeding into an annular passage opening into the induction tube via three small holes.

The "Olympic" incorporates a starter spring as standard. This is virtually an essential item. There is considerable "kick back" when hand starting, particularly on smaller propellers, and with manual starting the engine is more likely to start and run backwards than forwards. Use of the spring ensures instantaneous starting in the right direction, provided the spring is wound backwards to its fullest extent when using the smaller propellers. If only half wound, the engine can still backfire and start in the wrong direction.

The spring is just the right size and power for the job, fitted as simply as possible. It does not appear to have any damaging effect on wooden propellers. The only thing that has to be watched is to hold the propeller by the tip and withdraw the fingers smartly outwards, otherwise the following blade raps (he hand). We have always been a little dubious as to the virtues of a spring starter for anyone but a beginner, but this is one the expert will really appreciate. Re-starting is instantaneous when hot without altering the needle or even priming. When cold, a fairly generous prime is advisable, with the needle slightly opened.

The "Olympic" was run on propeller loads down to 7,000 r.p.m. where it was still most consistent and smooth running, although there was some falling off in torque. Torque is well maintained at the higher speeds, accounting for the high peak r.p.m. figure. Even over the lower part of the

# Cox Olympic .15

torque curve, however, performance is up to the best "diesel" standards, so this is truly a remarkably efficient engine.

It would not even seem necessary to try to use anything like peak r.p.m. for contest performances, in fact. A worked Frog nylon 9x6 propeller would probably give an outstanding performance and possibly speed up to something approaching 14,000 r.p.m. in the air. Any propeller which gave more than about 14,000 static r.p.m. on the ground would probably over speed in the air, with some loss of power. The power peak is, however, very broad and flat, so propeller selection should be far from critical. An "ideal" size would appear to be something like an 8x4, 9x3, or 9x2 for free flight, and a 6 inch pitch propeller for control line (higher pitch for sheer speed). To accommodate 3 inch pitch propellers, the propeller shaft screw requires shortening.

Constructionally the "Olympic" features a soft steel cylinder screwing into a turned crankcase unit. The cylinder is bored before precision honing to obvious very high standards. The bottom of the bore is slightly relieved and the cylinder unit treated for an oxidised black finish. The light alloy head, incorporating the glow element, screws into the top of the cylinder and seats on a copper gasket. All threads are an excellent fit. Diametrically opposed exhaust ports are cut in the cylinder walls. The two transfer ports are milled on the inside up between the land areas between the exhaust ports.

The piston is of steel, hardened on the outer rubbing surface only. The connecting rod, also of hardened steel, is ball ended and locked into a "cup" shape formed inside the piston head by peening over. There is a certain amount of up and down play in the fitted assembly, but this is of no consequence. Similarly, the hardness of the con. rod and crankpin appear to be of suitable values to eliminate wear.

The crankshaft is of relatively small diameter, 1/2 in., and runs on two ball races, one at each end of the bearing. Again the fit is delightfully free and true, as with the piston/cylinder assembly. The piston will, in fact, fall to bottom dead centre

under gravity. The shaft terminates in the prop driver and the extension shaft for carrying the propeller comprises a .160 in. diameter American No. 8 NC thread screw. The driver boss, however, is 1/4 in. diameter, requiring this size clearance hole in the propeller hub.

The reed valve assembly has been simplified over earlier Cox designs and features a single reed with tag ends loosely located by a wire clip. Fuel induction is via the three small spray distributing holes, connecting to the needle valve. The needle valve unit can be set in any convenient position and has an easy to manipulate thimble locked by a neat design of spring. It is fed by a comparatively large bore jet to the metering orifice which has been enlarged since the original Olympic production batch, and the choke tube reduced to approx. 1/5 in. bore at the same time to improve suction.

Everything about the Cox "Olympic", in fact, is neat and attractive. The colouring on the induction assembly, propeller driver and cylinder enhances the attraction of the polished machined parts. The presentation is equally eye-catching with moulded plastic base and "bubble pack" top, the engine backed by a printed red, gold and blue card. The final "proof of the pudding", how it performs, is even more attractive. This is truly a top class engine in every respect.

## SPECIFICATION

**Displacement:** 2.423 c.c. ( .1478 cu. in.)

**Bore:** .585 in.

**Stroke:** .55

**Bore/Stroke ratio:** 1.07

**Bare weight:** 4 or.

**Max. B.H.P.:** .287 at 16,500 r.p.m.

**Max. Torque:** 22 ounce inches at 10,000 r.p.m.

**Power rating:** .118 B.H.P. per c.c.

**Power Weight ratio:** .072 B.H.P. per oz.

## Material Specification

**Crankcase:** Light alloy, machined from bar stock

**Cylinder:** Mild steel

**Piston:** Hardened steel

# Cox Olympic .15

**Connecting rod:** Hardened steel

**Crankshaft:** Hardened steel

**Main bearing:** Twin ball races

**Cylinder head:** Light alloy (integral glow element)

**Rear cover and venturi:** Light alloy (anodised red)

**Prop driver:** Light alloy (anodised blue)

**Manufacturers:** I. M. Cox Manufacturing Co.,  
Santa Ana, California, U.S.A.

**Price in U.S.:** \$12.98

## PROPELLER R.P.M. FIGURES

Propeller dia.x pitch	r.p.m.
10x4 Trucut	7.300
9x4 Trucut	11.200
8x4 Trucut	13.800
8x3 Trucut	14.000
7x6 Trucut	12.600
9x3 Tiger	12.400
8x4 Tiger	14.800
10x6 Frog nylon	7.800
9x6 Frog nylon	10.200
7x4 Frog nylon	16.000 plus

**Fuel:** 20 per cent, nitromethane 20 per cent, castor, 60 per cent, methanol.

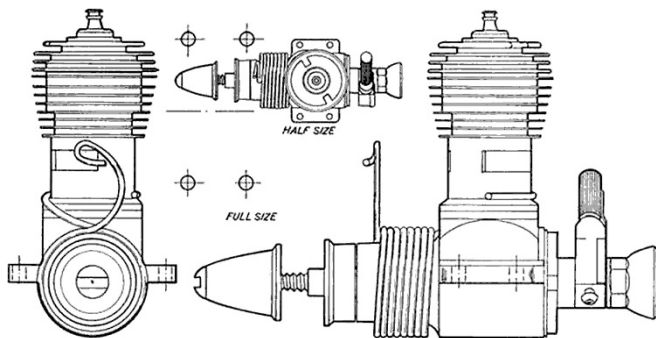

**More:** [https://flyinghlsat.com/search.php?search\\_keywords=Cox-Engines](https://flyinghlsat.com/search.php?search_keywords=Cox-Engines)