

600 SQ. IN. FORMULA II RACER
 PLATE 1 OF 2

PIÑATA

DESIGNED BY ED AVERKIEFF
 DRAWN BY RAY VAN DE WALKER
 INKED BY GERARDO FLORES

0 1 2 3 4 5 6

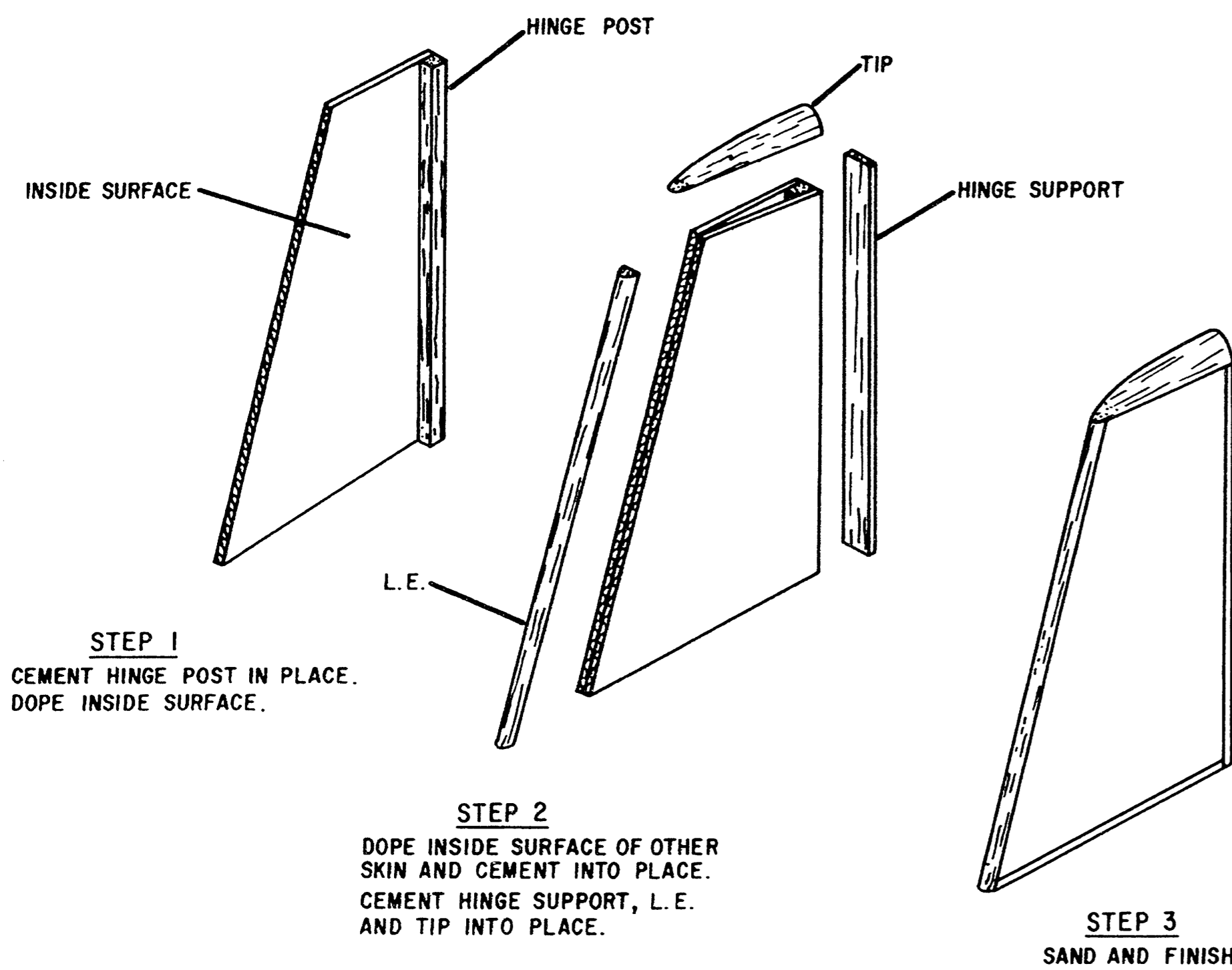

VERTICAL STABILIZER CONSTRUCTION
FIGURE 1

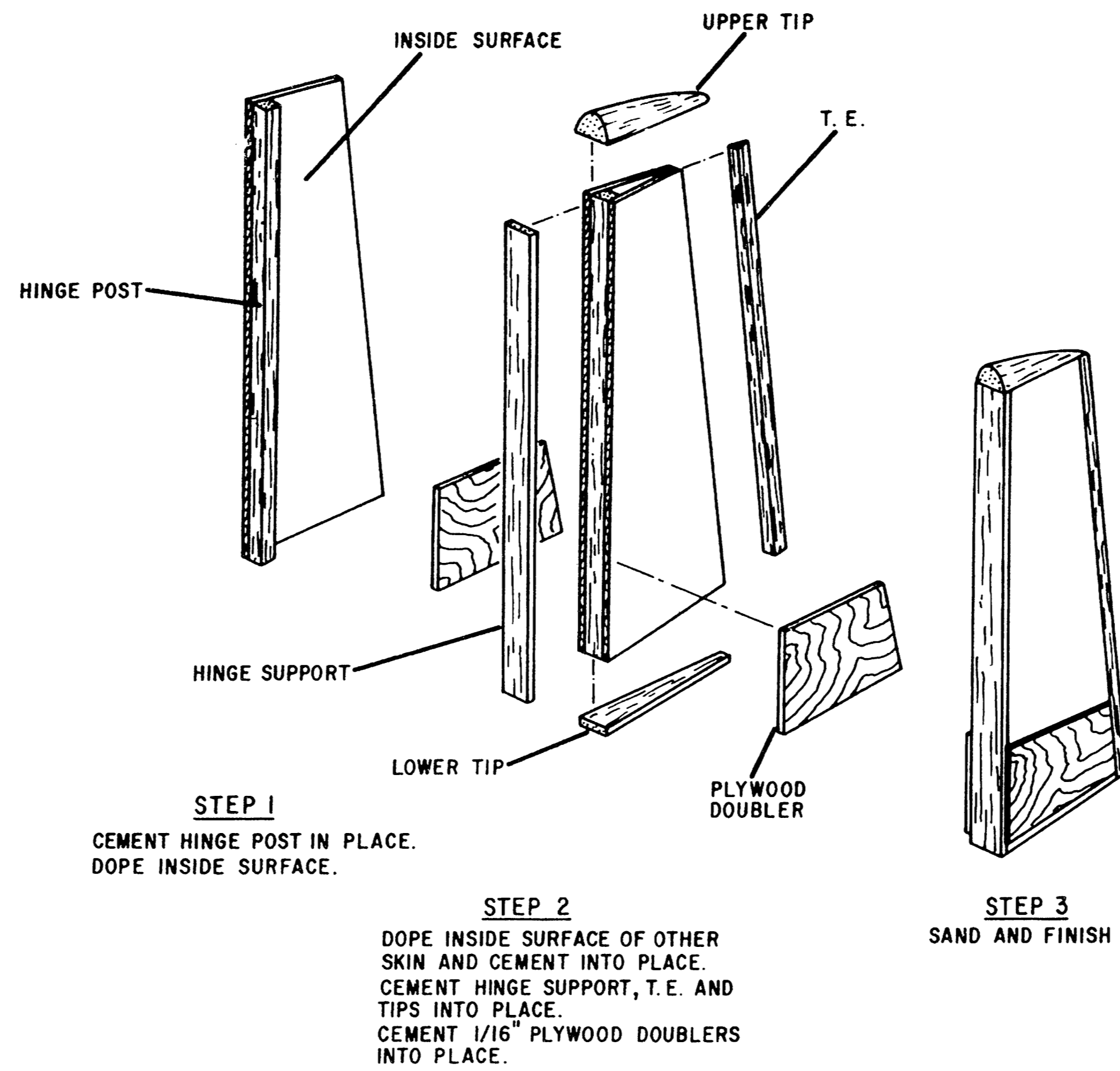

RUDDER CONSTRUCTION
FIGURE 2

STEP 1
CEMENT HINGE POST IN PLACE.
CEMENT CENTER POST IN PLACE.
DOPE INSIDE SURFACE.

STEP 2
DOPE INSIDE SURFACE OF OTHER SKIN AND CEMENT INTO PLACE.
CEMENT HINGE SUPPORT, L.E. AND TIPS INTO PLACE.

STEP 3
SAND AND FINISH

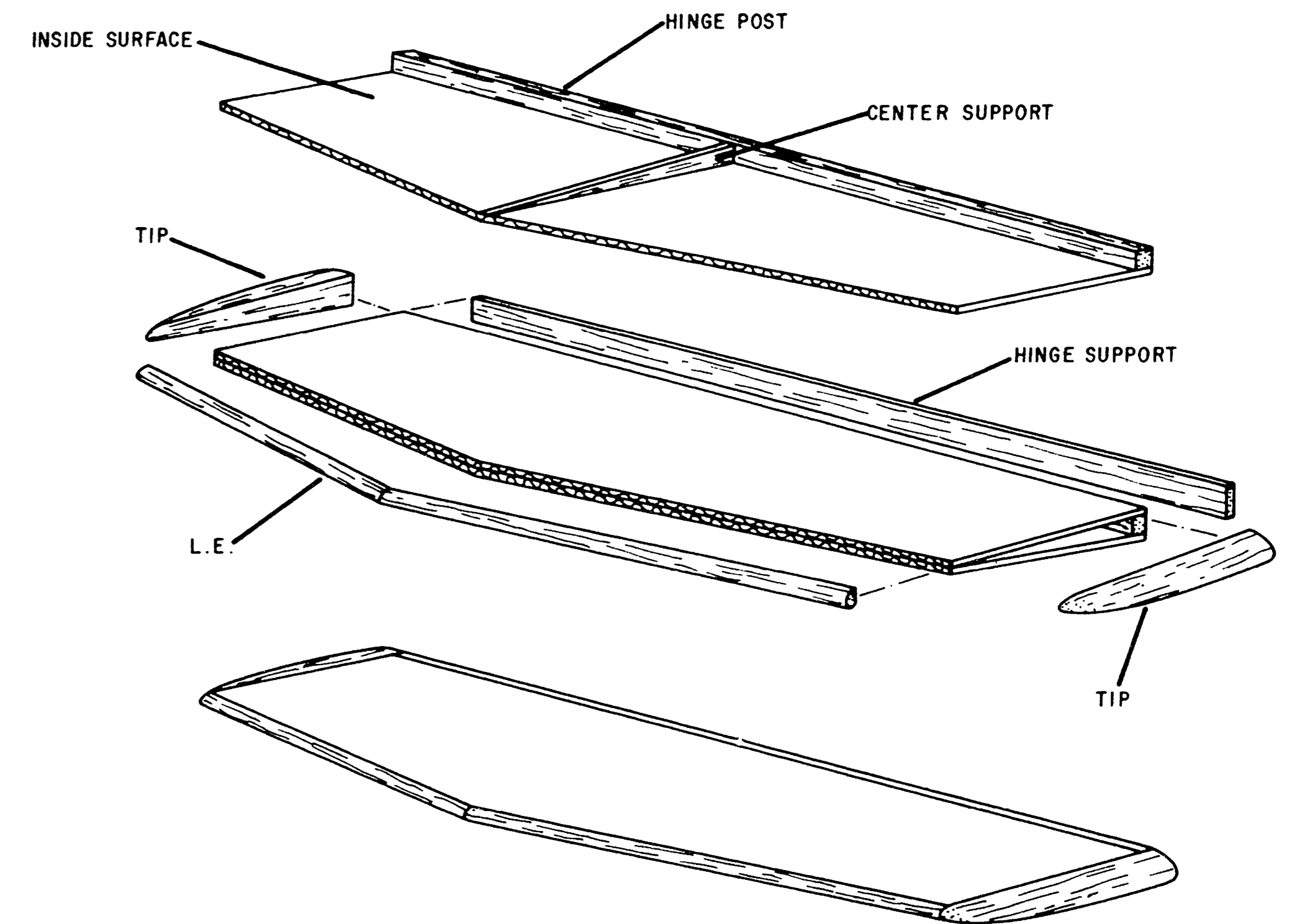

HORIZONTAL STABILIZER CONSTRUCTION
FIGURE 3

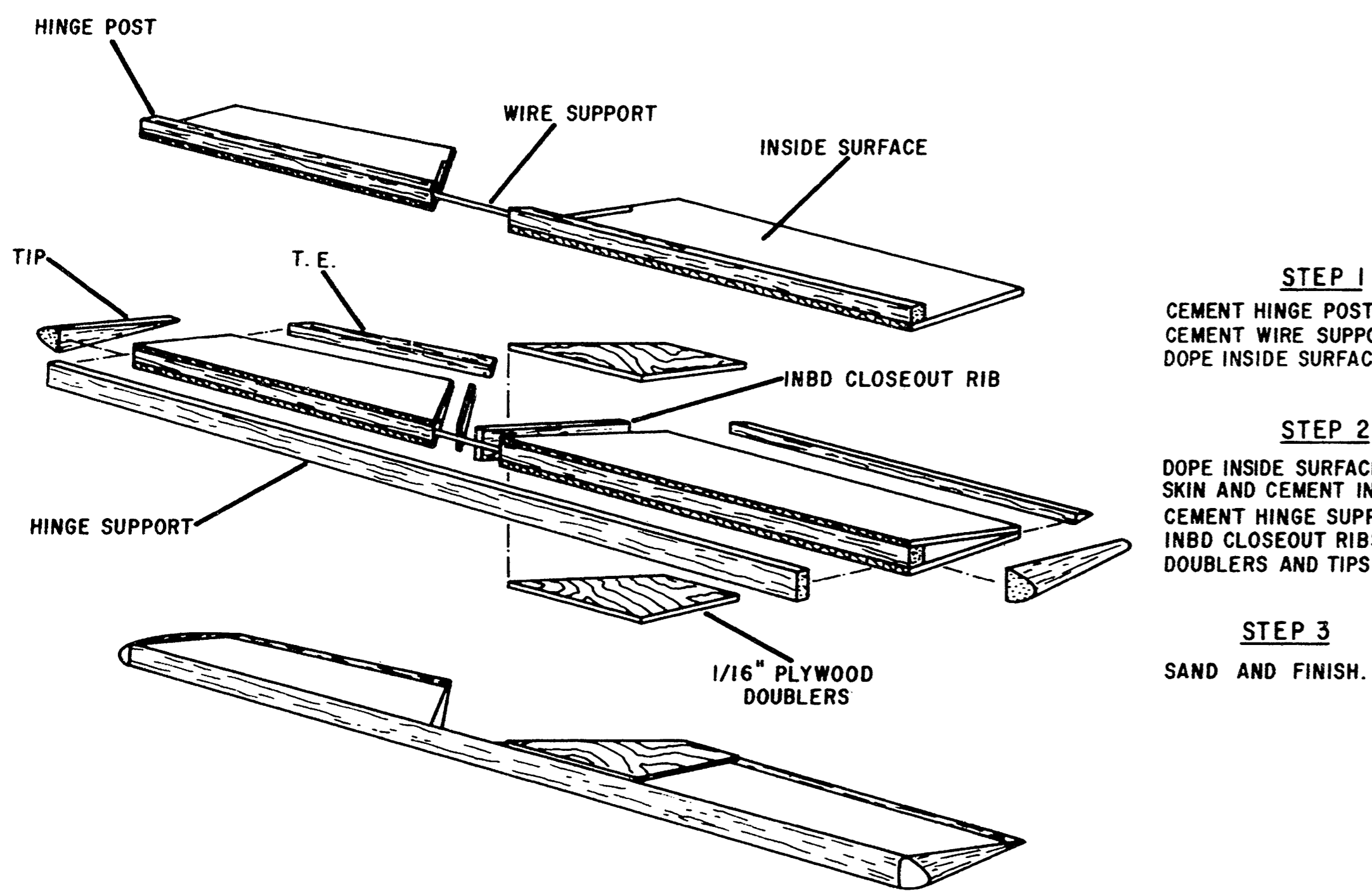

ELEVATOR CONSTRUCTION
FIGURE 4

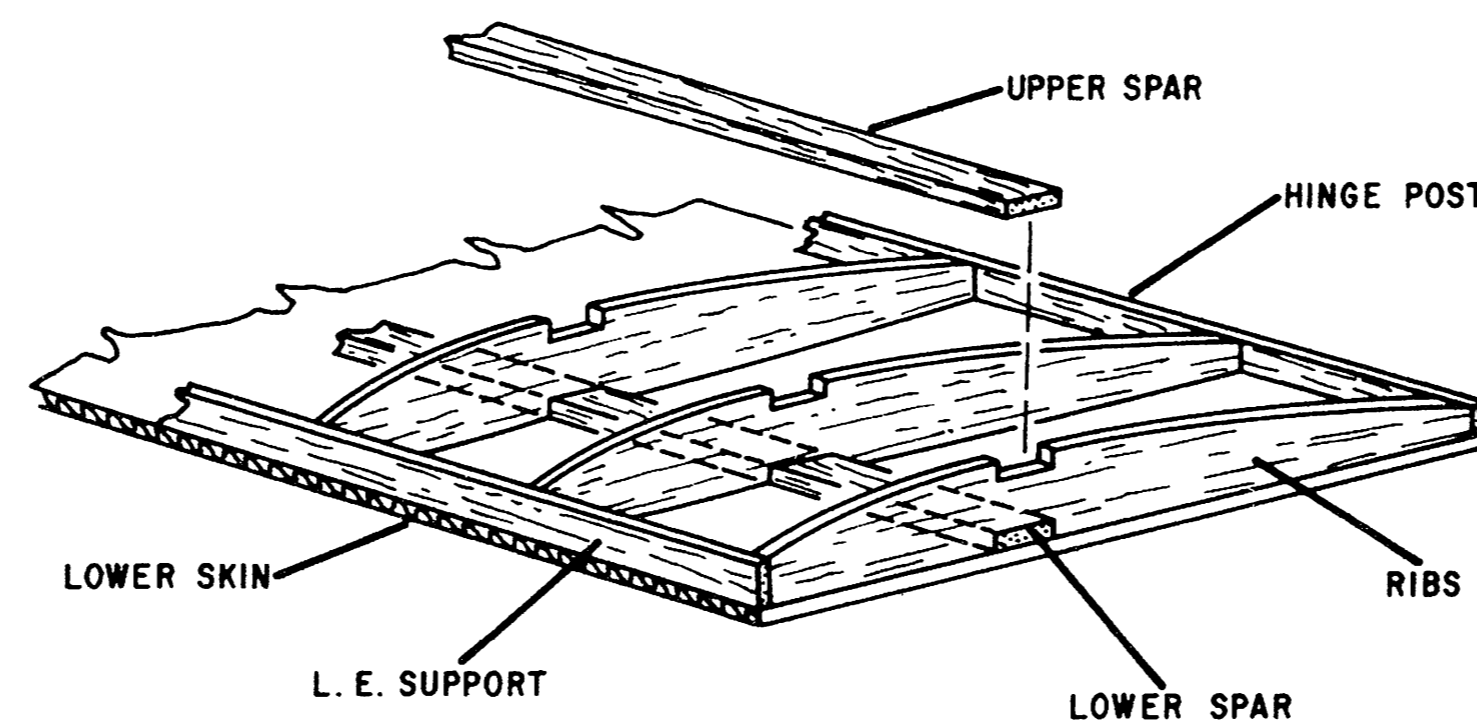

WING CONSTRUCTION-LOWER SKIN ASSEMBLY
FIGURE 5

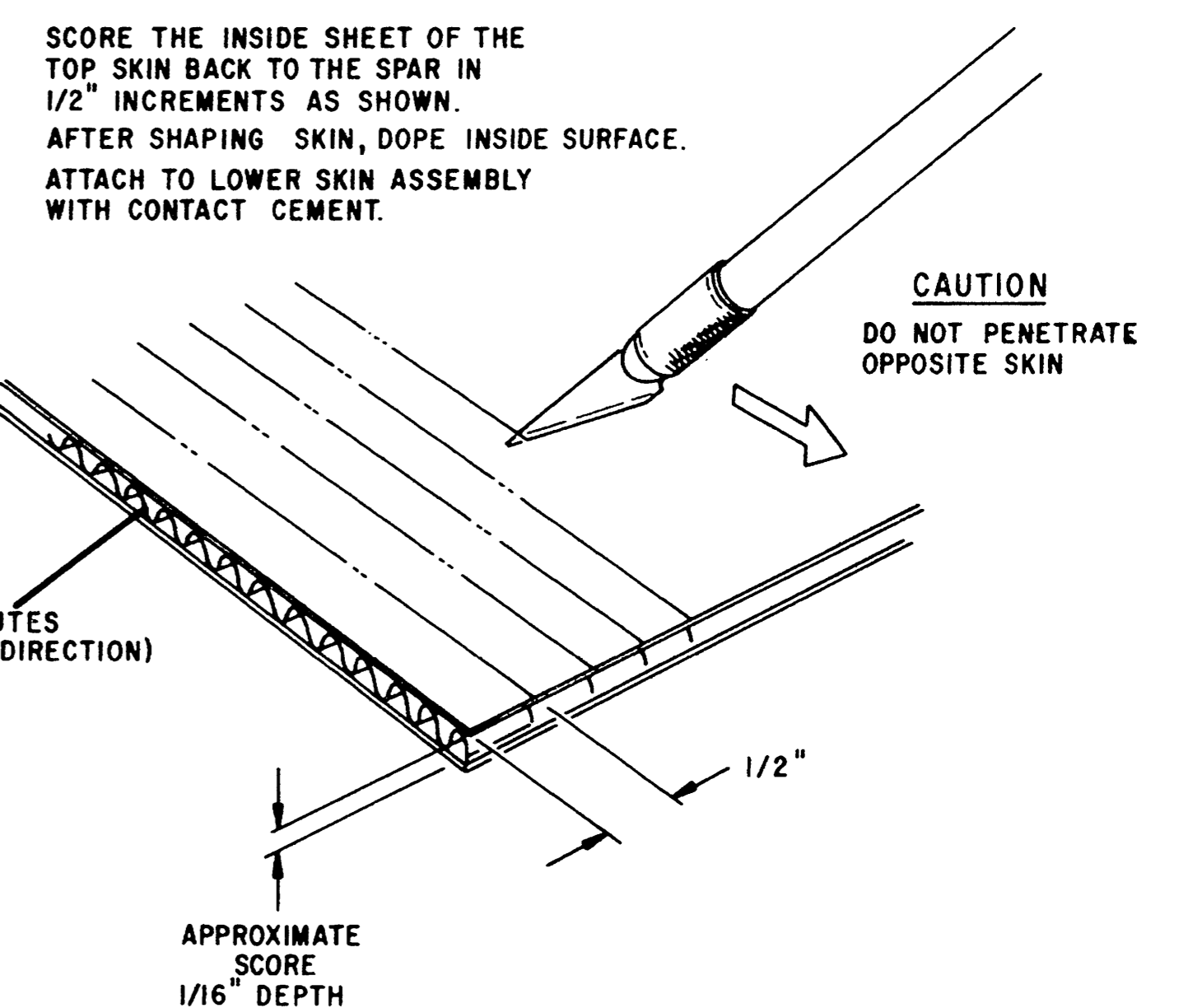

SHAPING CORRUGATED SKIN
FIGURE 6

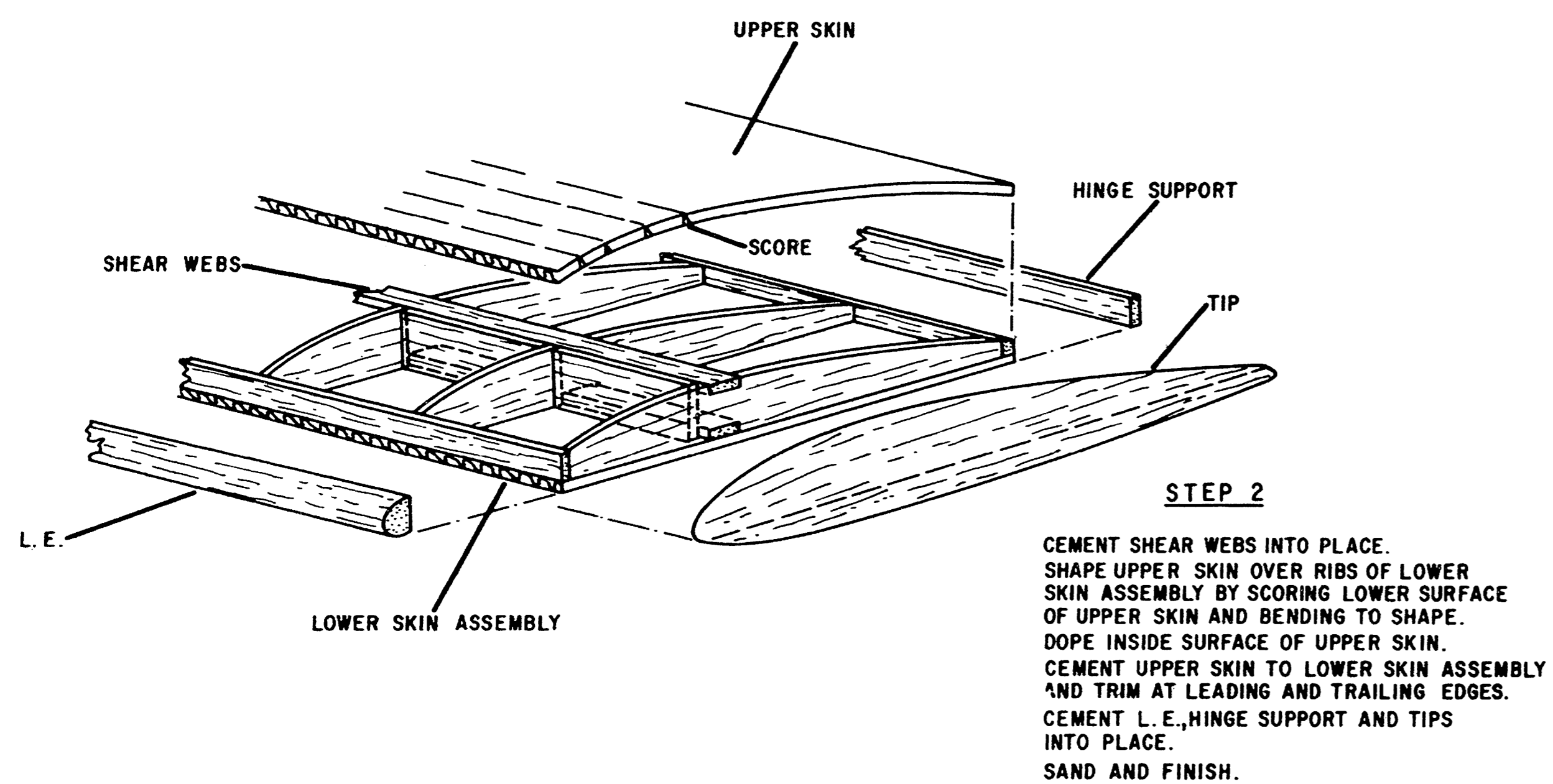

WING CONSTRUCTION- FINAL ASSEMBLY
FIGURE 7

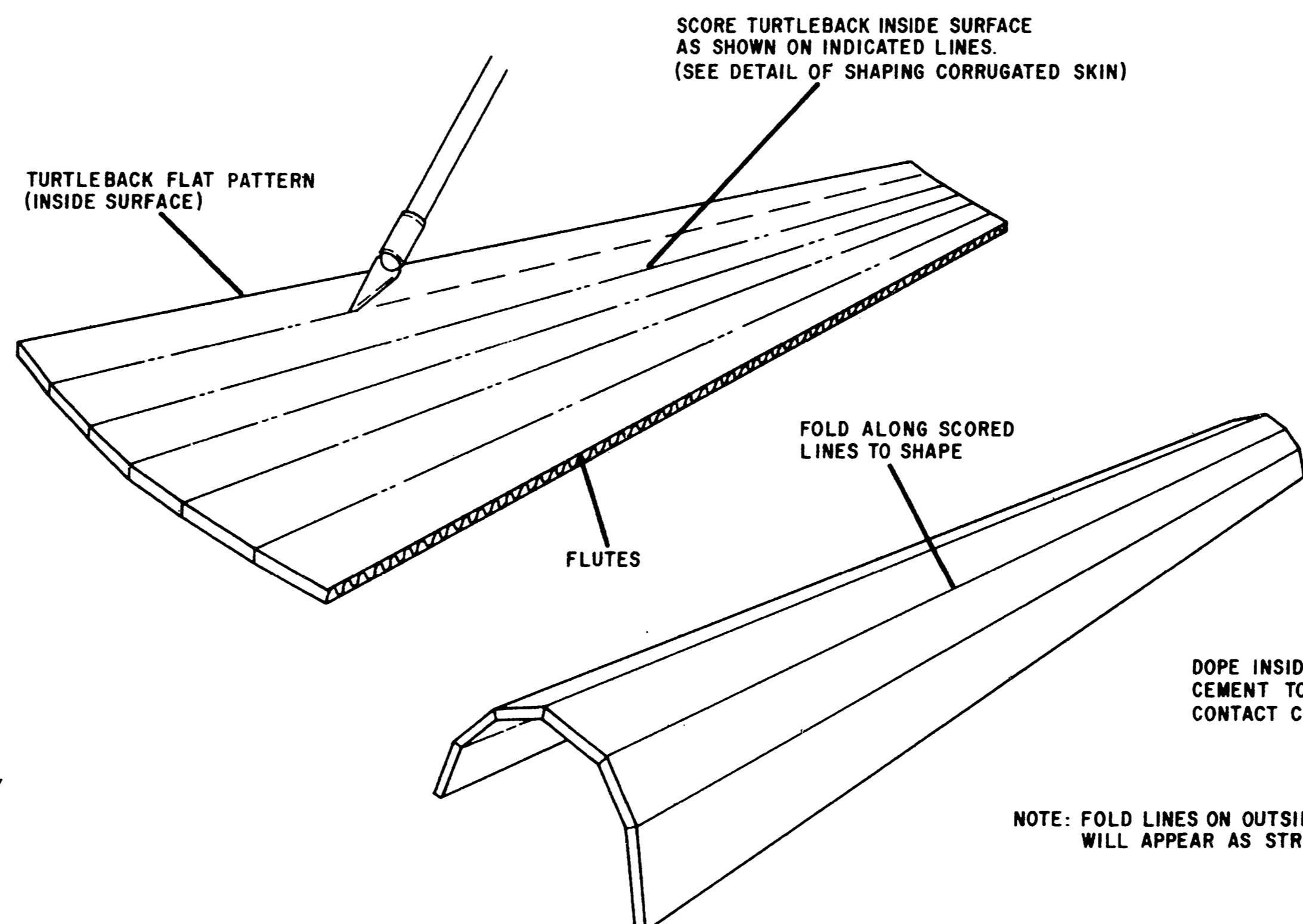

TURTLEBACK CONSTRUCTION
FIGURE 8

DOPE INSIDE SURFACE AND CEMENT TO FUSELAGE WITH CONTACT CEMENT.

NOTE: FOLD LINES ON OUTSIDE SKIN WILL APPEAR AS STRINGERS

600 SQ. IN. FORMULA II RACER

PLATE 2 OF 2



PIÑATA

DESIGNED BY RAY VAN DE WALKER INKED BY GERARDO FLORES
DRAWN BY ED AVERKIEFF

