

NOTE: THE BASIC FUSELAGE FRAMEWORK SHOWN IS 1/4" SQ. BALSA & SPRUCE, AND IS INTENDED FOR THE R/C ENGINE POWERED VERSION. IF THE ELECTRIC POWERED VERSION IS TO BE BUILT, 3/16" SQ STOCK MAY BE SUBSTITUTED. THE 1/8" MUSIC WIRE LANDING GEAR LEGS MAY BE REDUCED TO 3/32" MUSIC WIRE. FOR ELECTRIC POWER ALSO, AND THE 1/32" PLYWOOD FUSELAGE DOUBLERS MAY BE REDUCED TO 1/64" PLYWOOD.

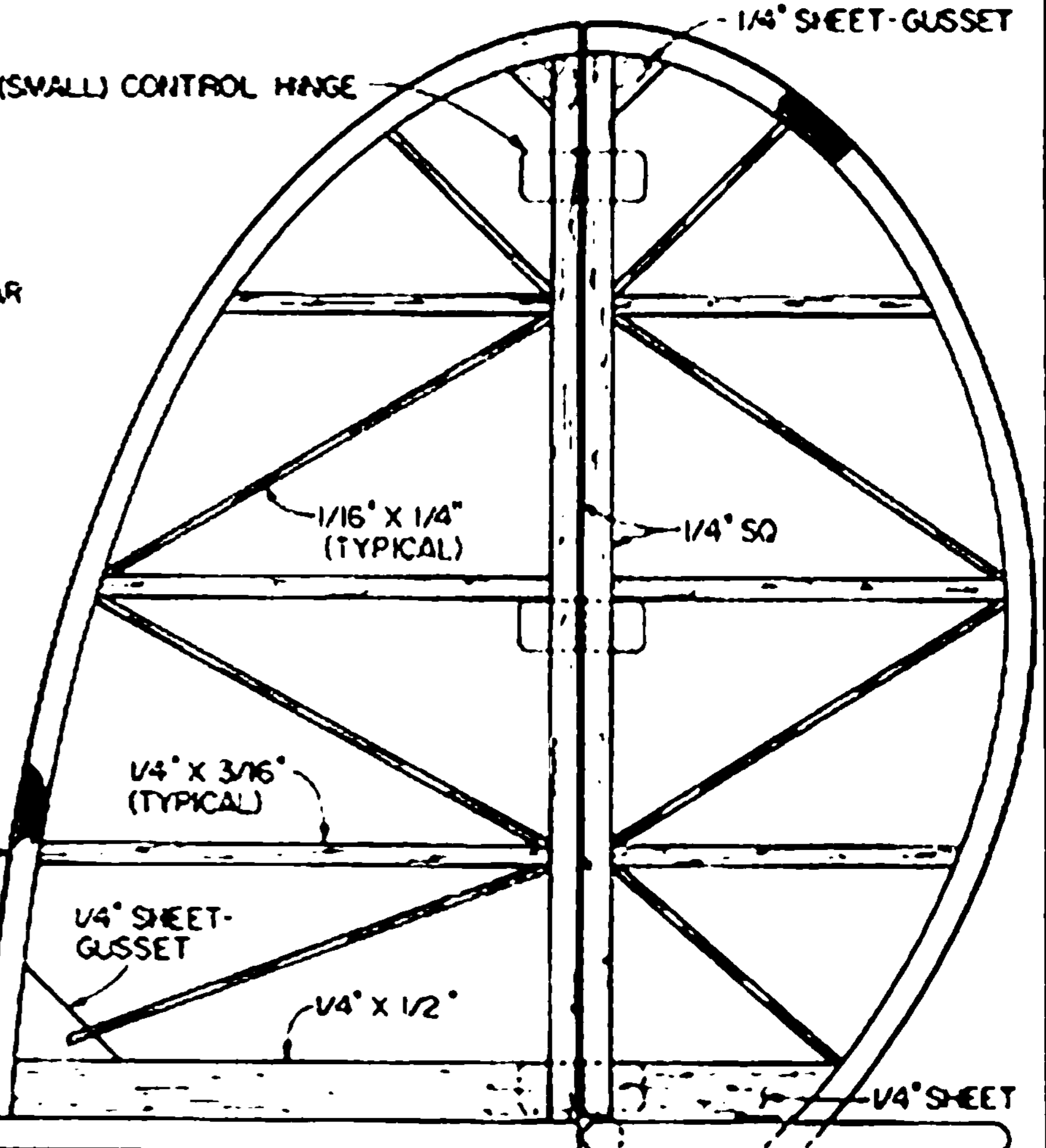

ELECTRIC POWER INSTALLATION DETAIL

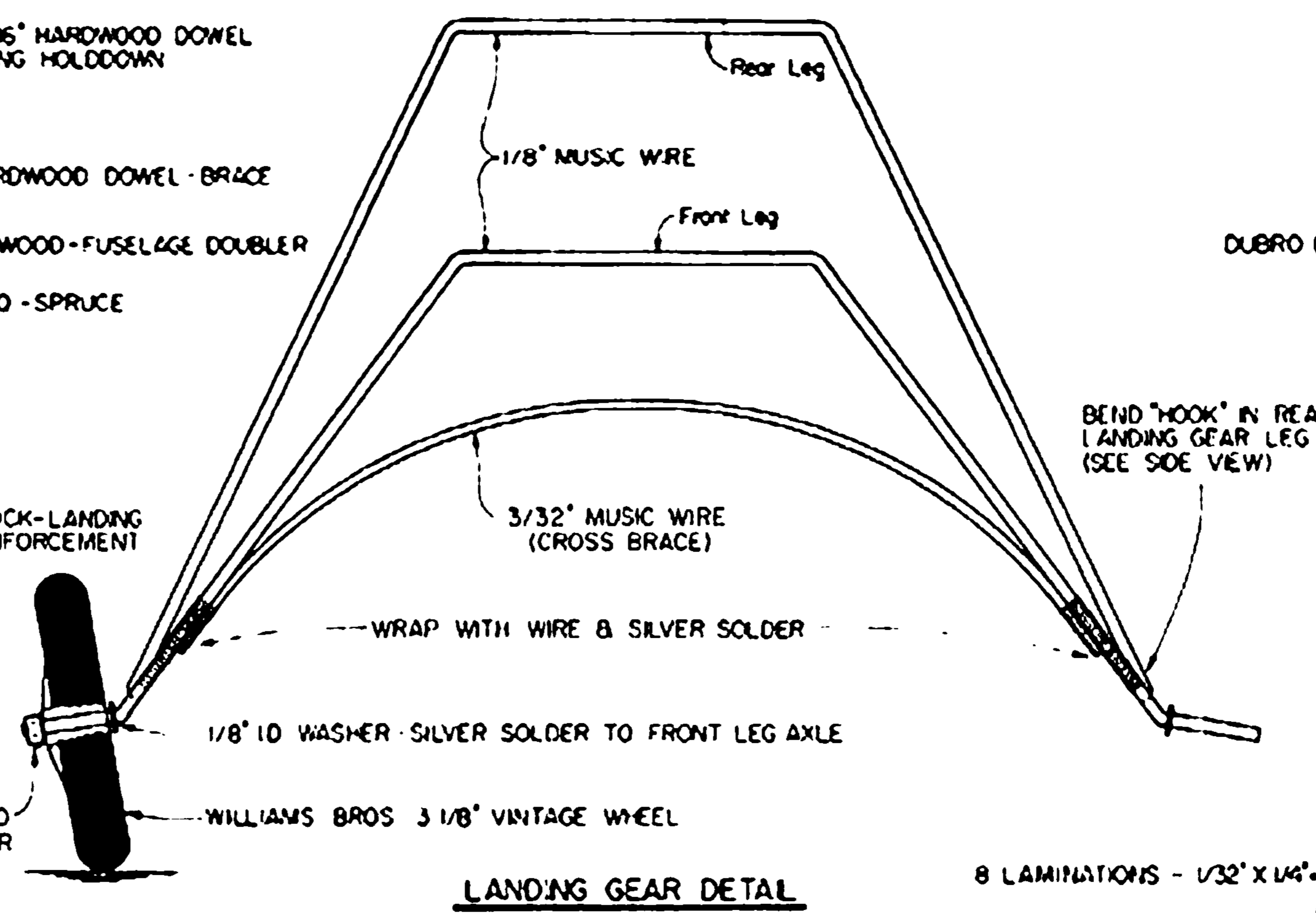
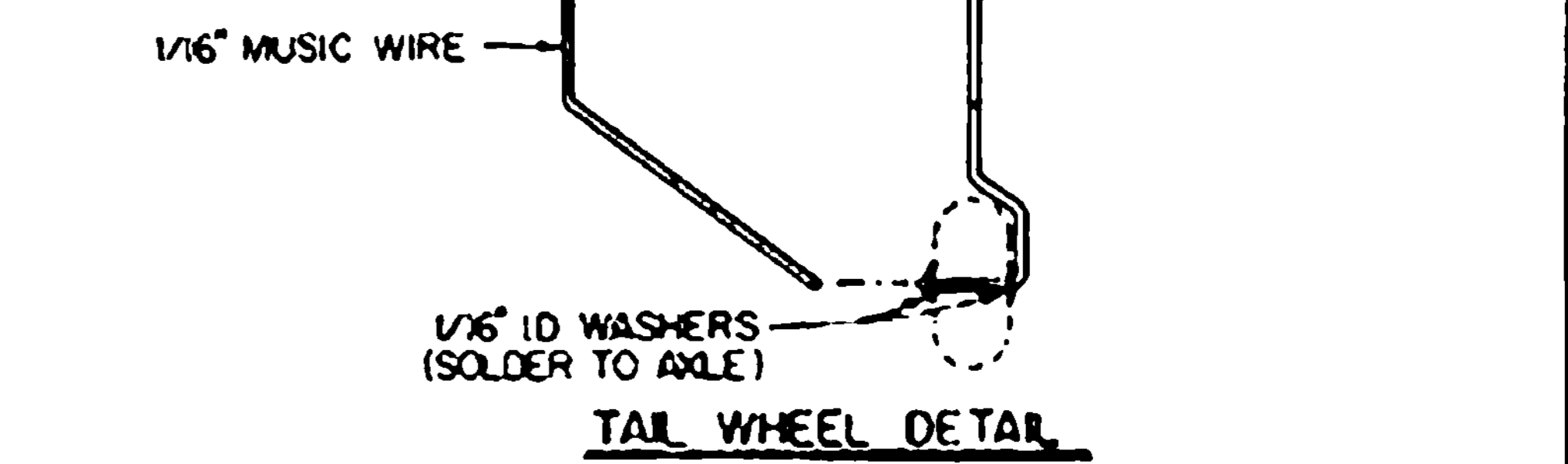
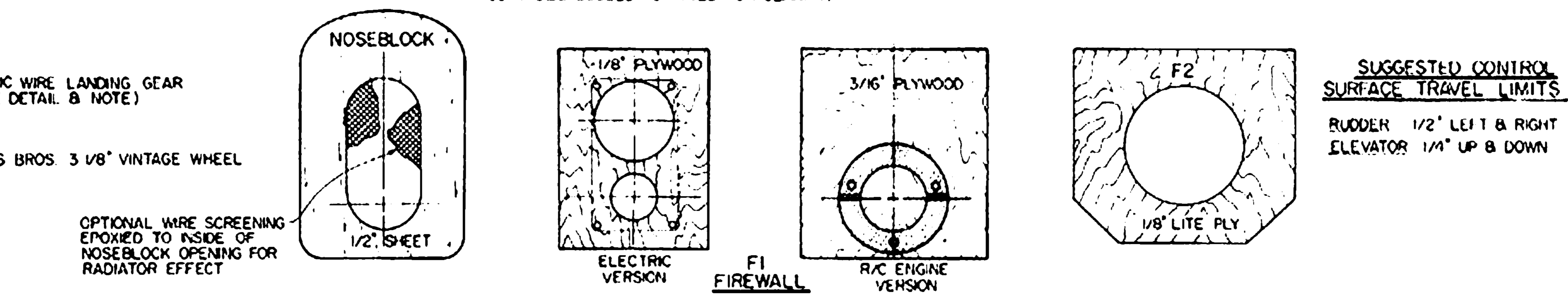
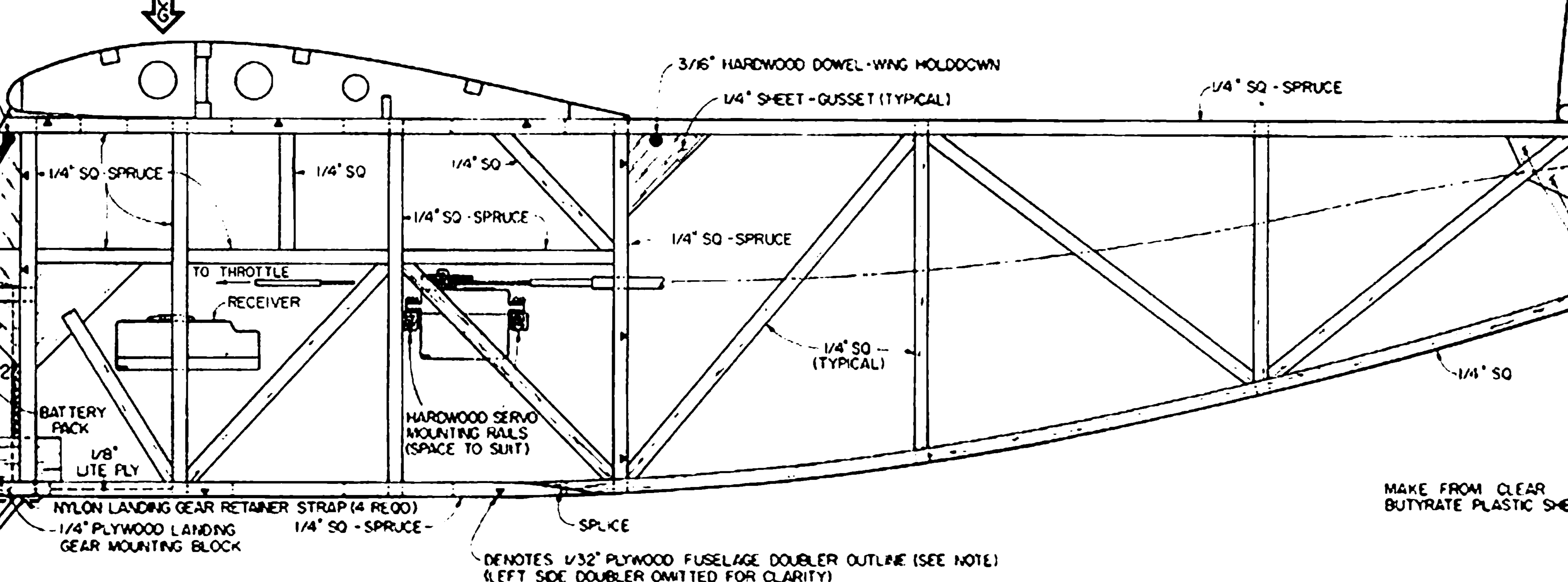
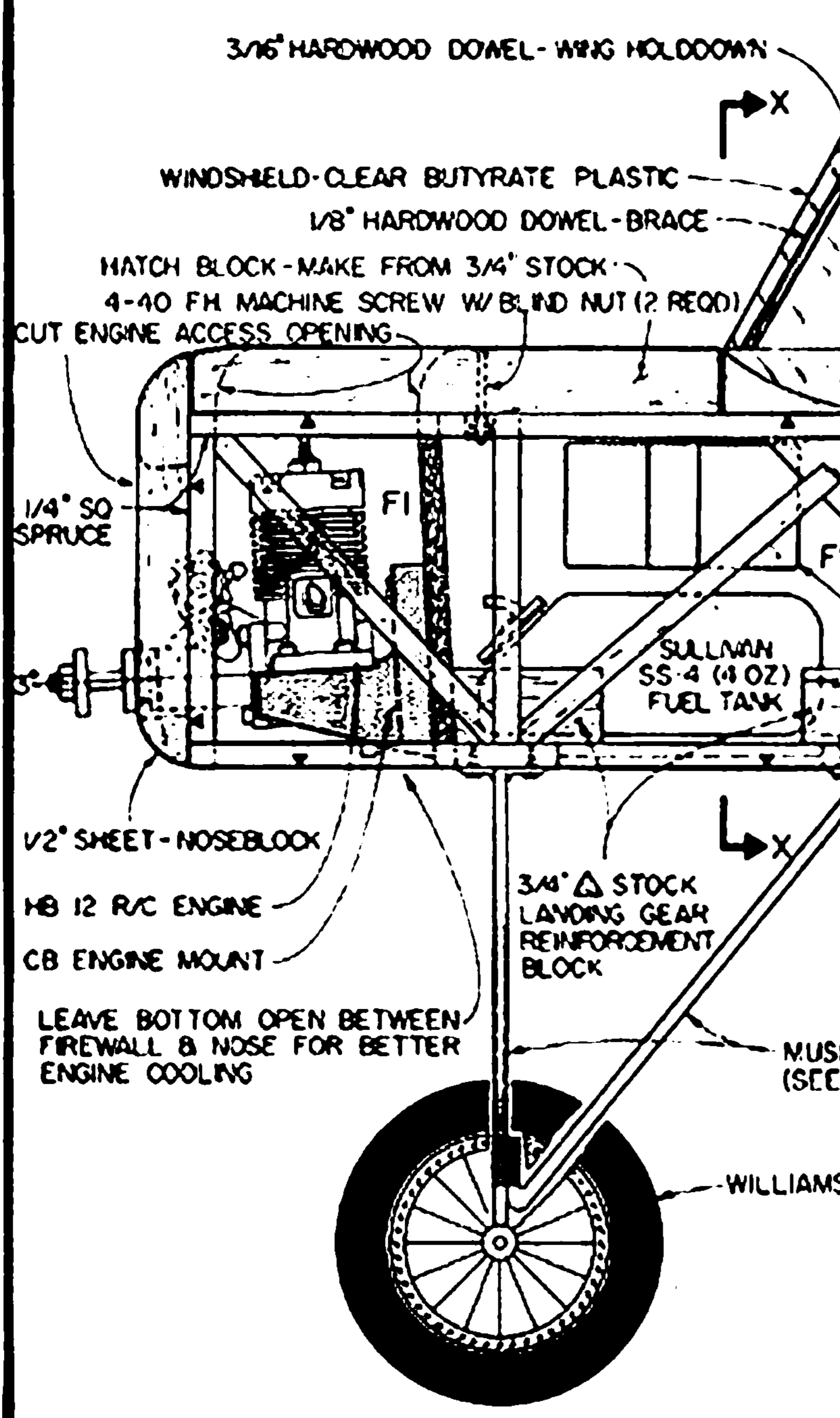

SUGGESTED CONTROL SURFACE TRAVEL LIMITS
 RUDDER: 1/2" LEFT & RIGHT
 ELEVATOR: 1/4" UP & DOWN

© 1964 ALL COMMERCIAL RIGHTS RESERVED

MISS PHILADELPHIA IV
 A VINTAGE OLD TIMER SPORT DESIGN
 FOR GEAR DRIVE OR ELECTRIC OR 09-19 R/C ENGINES

ORIGINAL DESIGN BY MAXWELL BASSETT
 R/C CONVERSION BY RANDY WHISLEY
 PLANS BY *Red Tealick*

