

NOTE: THE FUSELAGE SIDE & FRONT VIEW, SHOWN TO THE RIGHT, ILLUSTRATE HOW THE LEFT ENGINE NACELLE IS MOUNTED TO THE WING. FIRST, COVER THE BOTTOM OF THE WING WITH MONOKOTE, THEN MAKE HOLES IN NACELLE & CUT HOLES IN BOTTOM SURFACE OF WING TO ACCEPT ALUMINUM STRUTS 31, 32, 33, 34, & 38, AS SHOWN. CAREFULLY LINE-UP THE NACELLE (22) AND APPLY (THIN VISCOSITY) CYANOACRYLATE, AT EACH STRUT JUNCTION POINT. THE VOIDS, AT THE STRUT ENTRY POINTS, ARE THEN FILLED WITH MICRO-BALLOONS & CYANOACRYLATE. INSTALL THE 3/4" Δ STOCK, INSIDE THE WING, BEND THE ENDS OF THE STRUTS AS SHOWN, AND EPOXY THEM IN PLACE. THE RIGHT ENGINE NACELLE IS INSTALLED (OPPOSITE HAND) IN IDENTICAL FASHION.

BOTH "DUMMY" OUTBOARD ENGINE NACELLES ARE EQUIPPED WITH "FREE-WHEELING" 9" DIAMETER PROPELLERS, WHICH ARE MOUNTED WITH 1/4-20 STEEL OR NYLON BOLTS, 1-1/2" LONG TWO 1" NYLON WASHERS ARE USED FOR EACH PROP AND THE BOLTS ARE ATTACHED TO 23 WITH 1/4-20 NUTS, ON BOTH SIDES OF 23. GLUE OR LOCTITE, NUTS SECURELY IN PLACE.

THIS AIRCRAFT FLIES BEST WITH A 12"-5"P OR 11"-5"P PROP TURNING 9,500-10,000 RPM, AT A SLIGHTLY RICH NEEDLE VALVE SETTING

STRUTS ARE SHOWN, BEFORE TOP ENDS ARE BENT DOWN AND GLUED

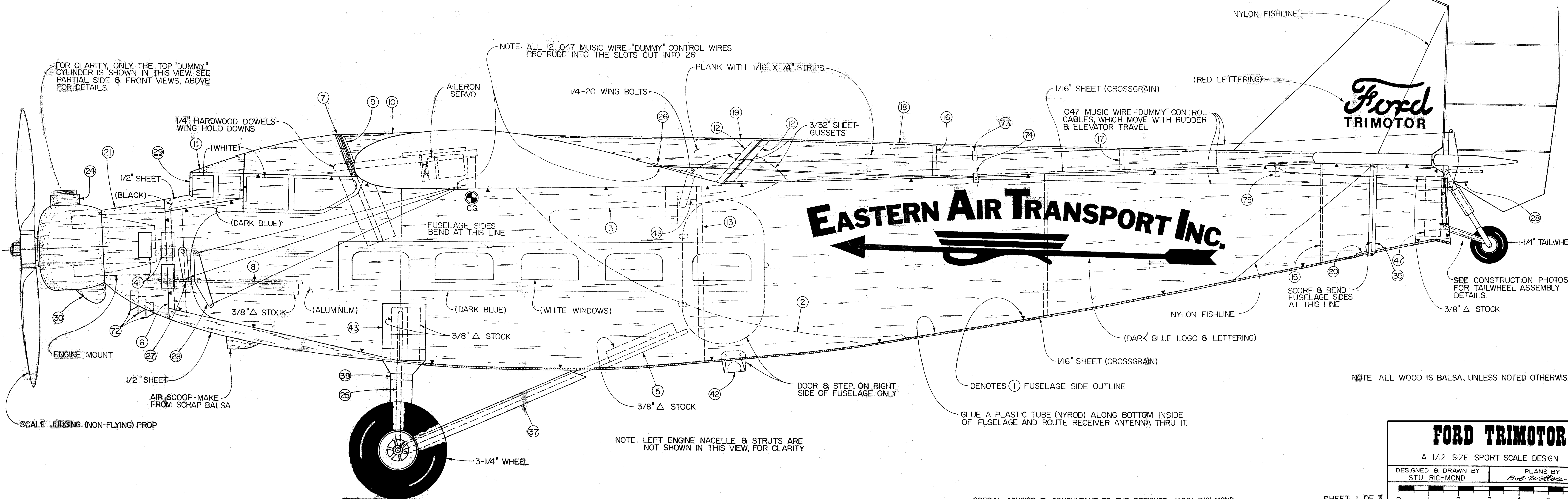
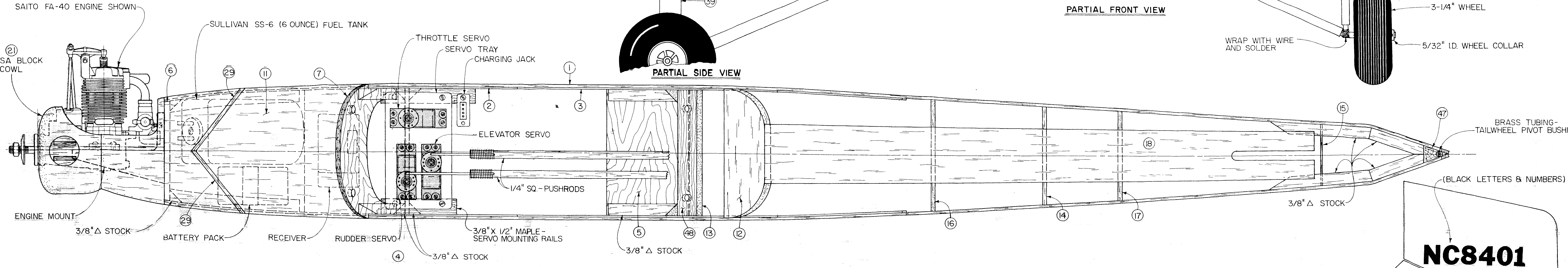
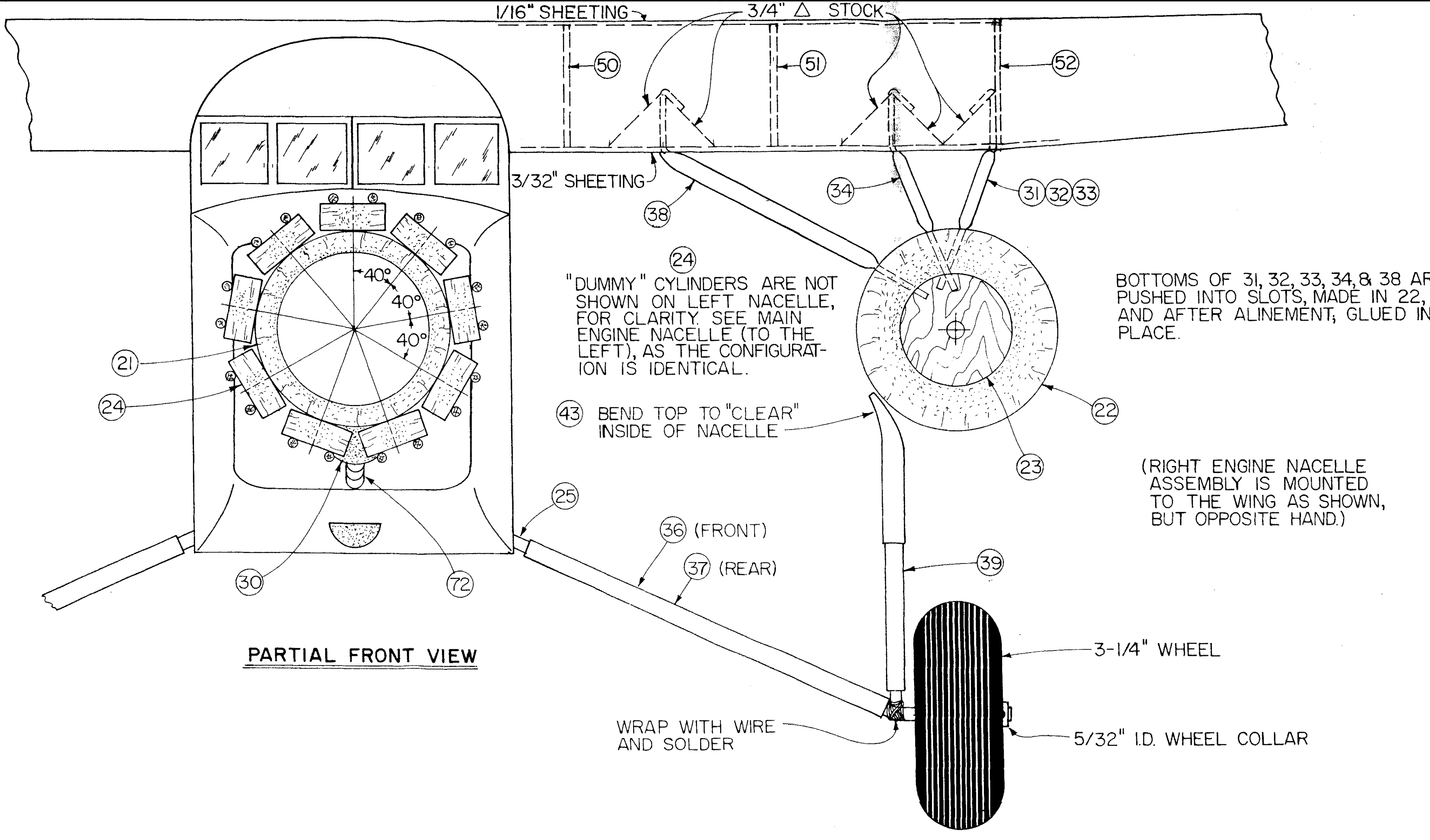
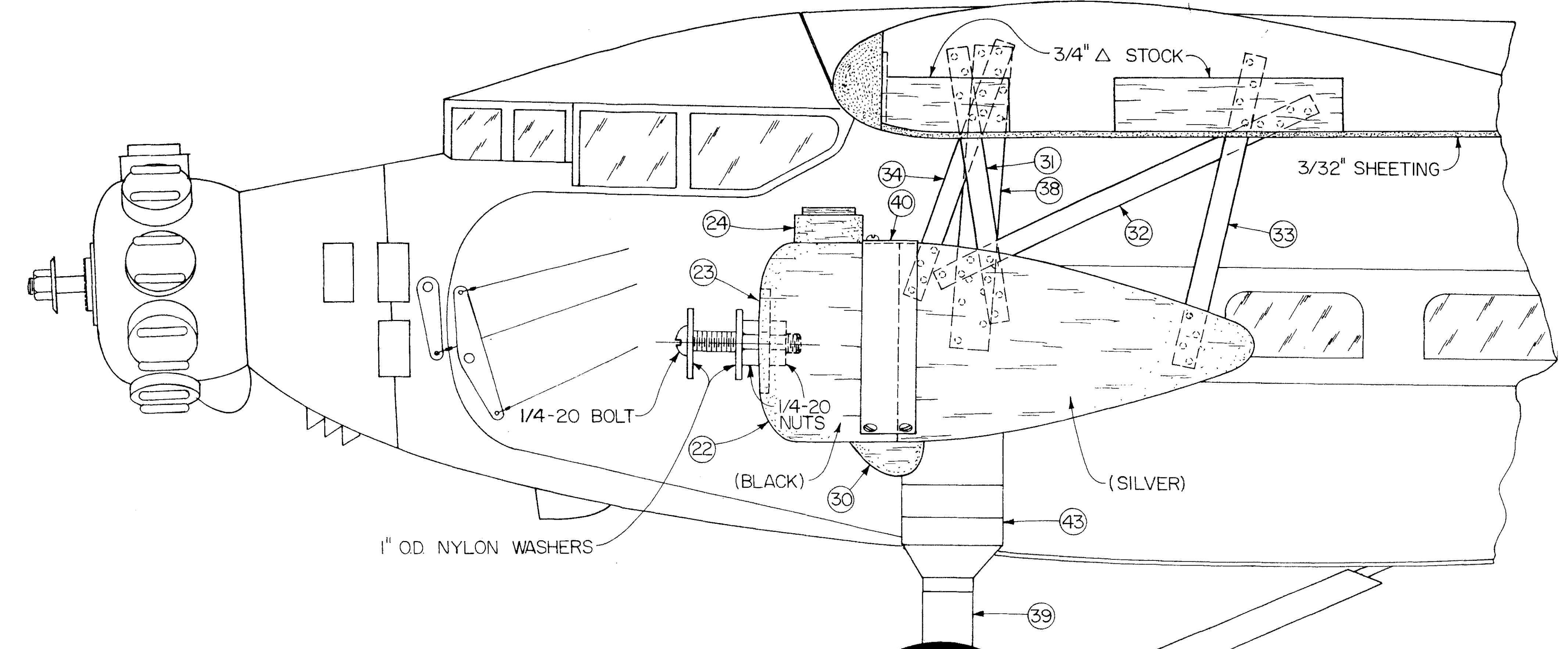

NC8401

EASTERN AIR TRANSPORT INC.

Ford TRIMOTOR

FORD TRIMOTOR
 A 1/12 SIZE SPORT SCALE DESIGN
 DESIGNED & DRAWN BY STU RICHMOND
 PLANS BY Bob Walton

NOTE: PARTS 44, 45, & 46 ASSEMBLE TO MAKE WING SPAR. SELECT THE STRAIGHTEST PIECES OF SPRUCE OR BASSWOOD AVAILABLE, WITH PARALLEL GRAIN ONLY.

NOTE: DO NOT USE BALSA, FOR WING SPAR PARTS!

1/4" X 1/2" - SPRUCE OR BASSWOOD
PART NO. 44 - 2 REQ'D

1/4" X 1/2" - SPRUCE OR BASSWOOD

NOTE CHANGE IN FUSELAGE SIDE TOP TAPER, FROM THIS POINT, AFT. THIS PROVIDES PROPER STABILIZER INCIDENCE.

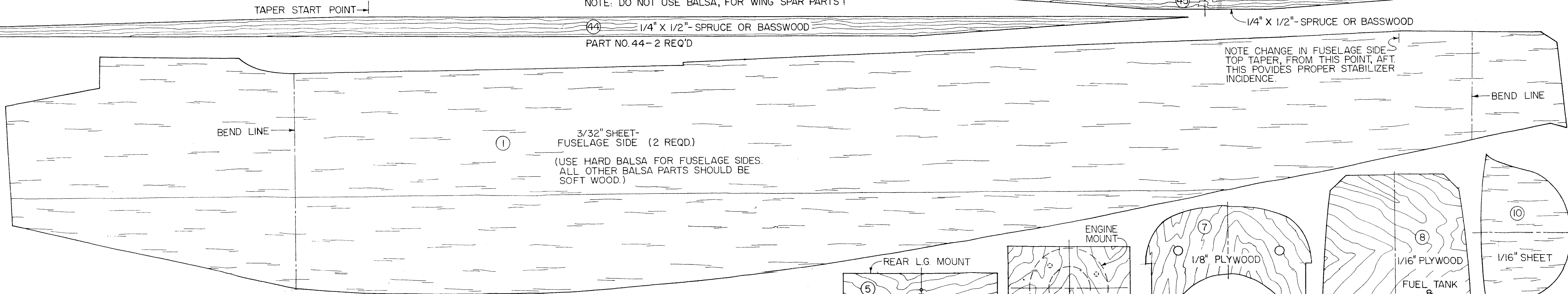
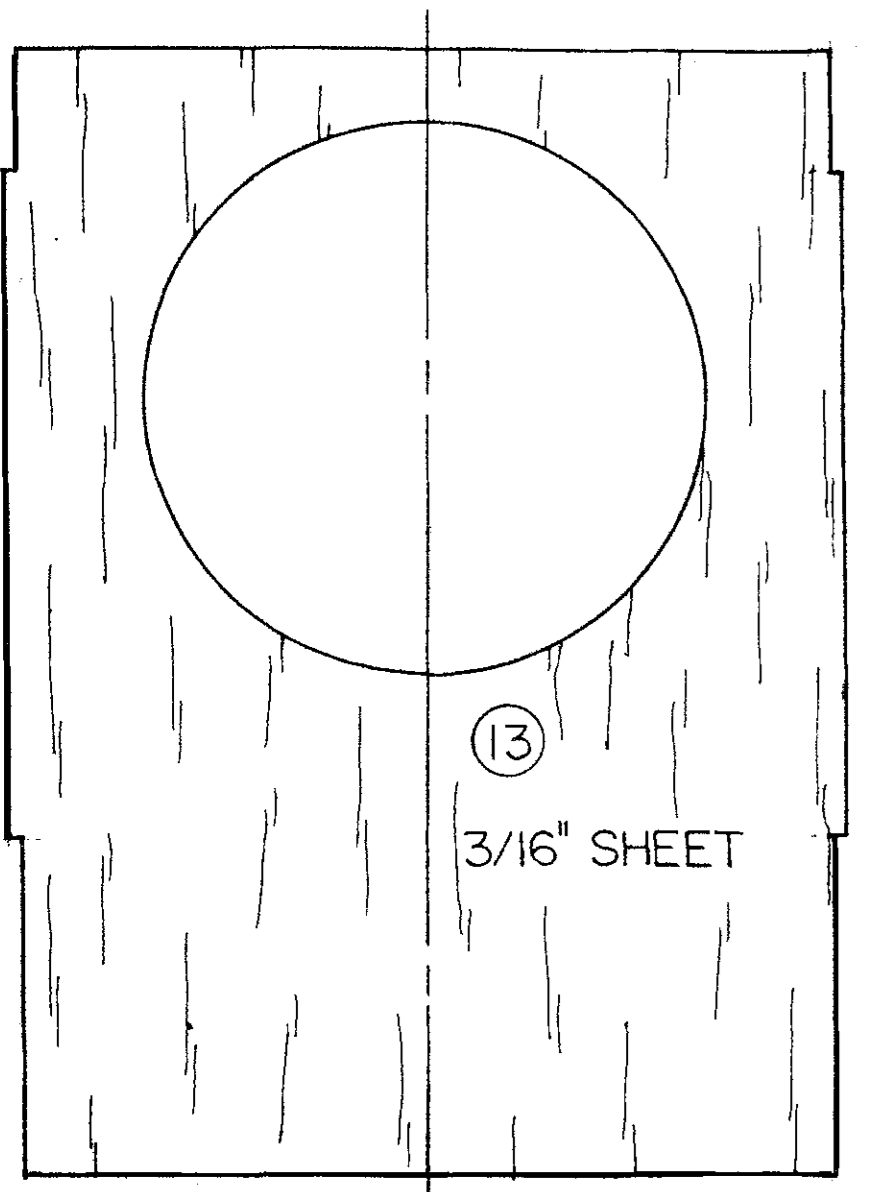

26
SOFT BROWN OR BLACK LEATHERETTE (6 REQ'D)

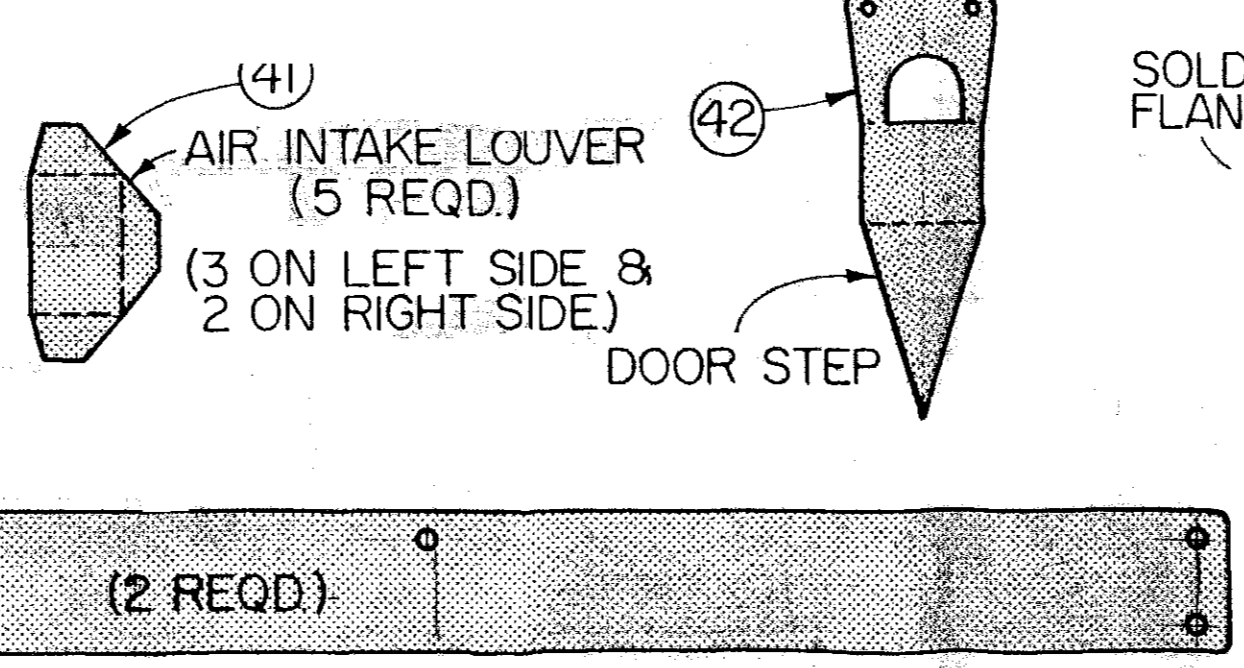
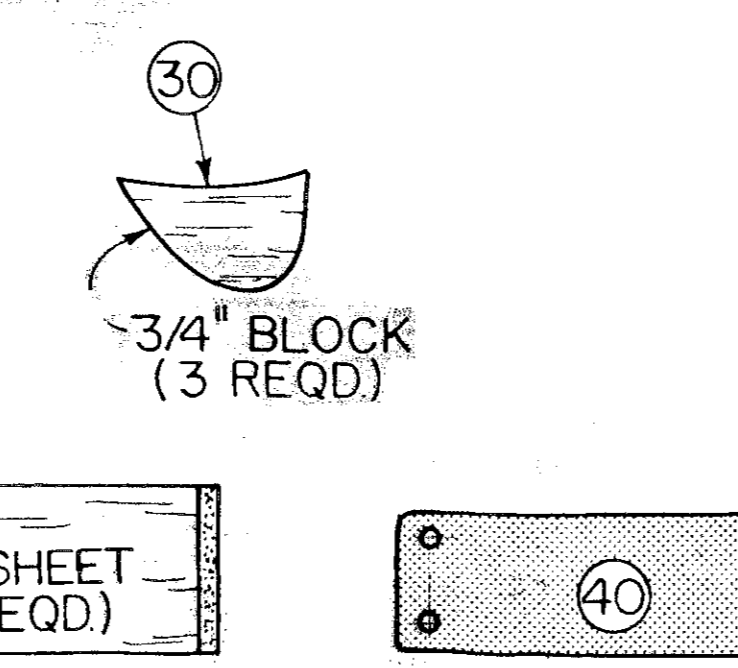
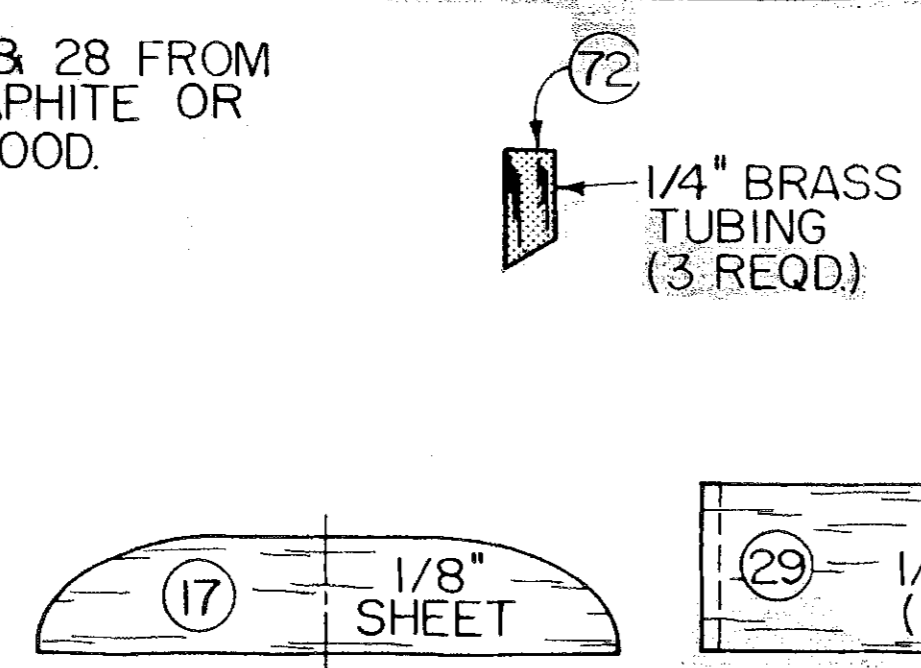
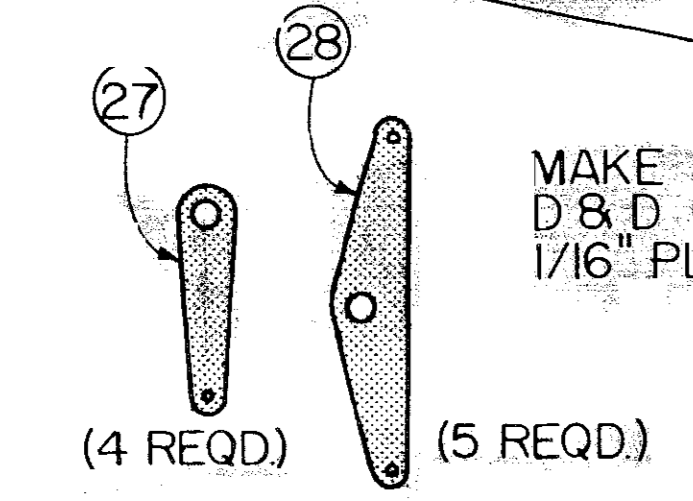
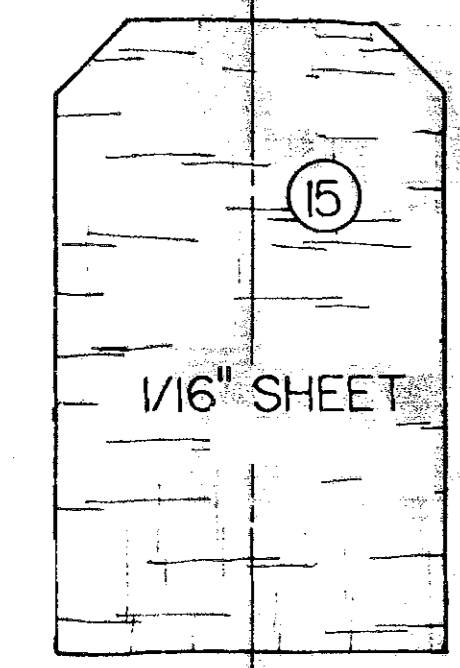
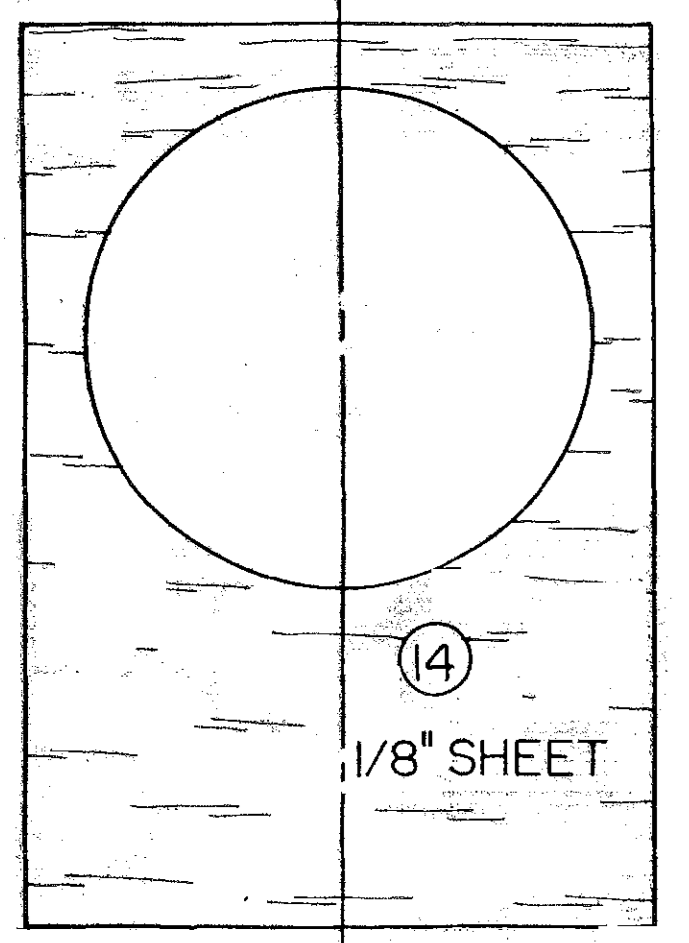

NOTE: PARTS 40 THRU 43 ARE CUT FROM K & S (NO 254) 008 TIN SHEET (4" X 10"). 40 IS GLUED & SCREWED IN PLACE, DIRECTLY BEHIND THE ENGINE CYLINDERS, ON THE OUTBOARD ENGINE NACELLES, AFTER THE NACELLES HAVE BEEN PAINTED. 41 & 42 ARE BENT 90° ON THE DASHED LINES. 43 IS GENTLY FOLDED ON (CENTER) DASHED LINE AND "STREAMLINED" TO FORM THE OLEO OF THE LANDING GEAR LEGS. THE FLANGE IS SOLDERED AS INDICATED, AND 43 IS SILICONED TO PART 39.

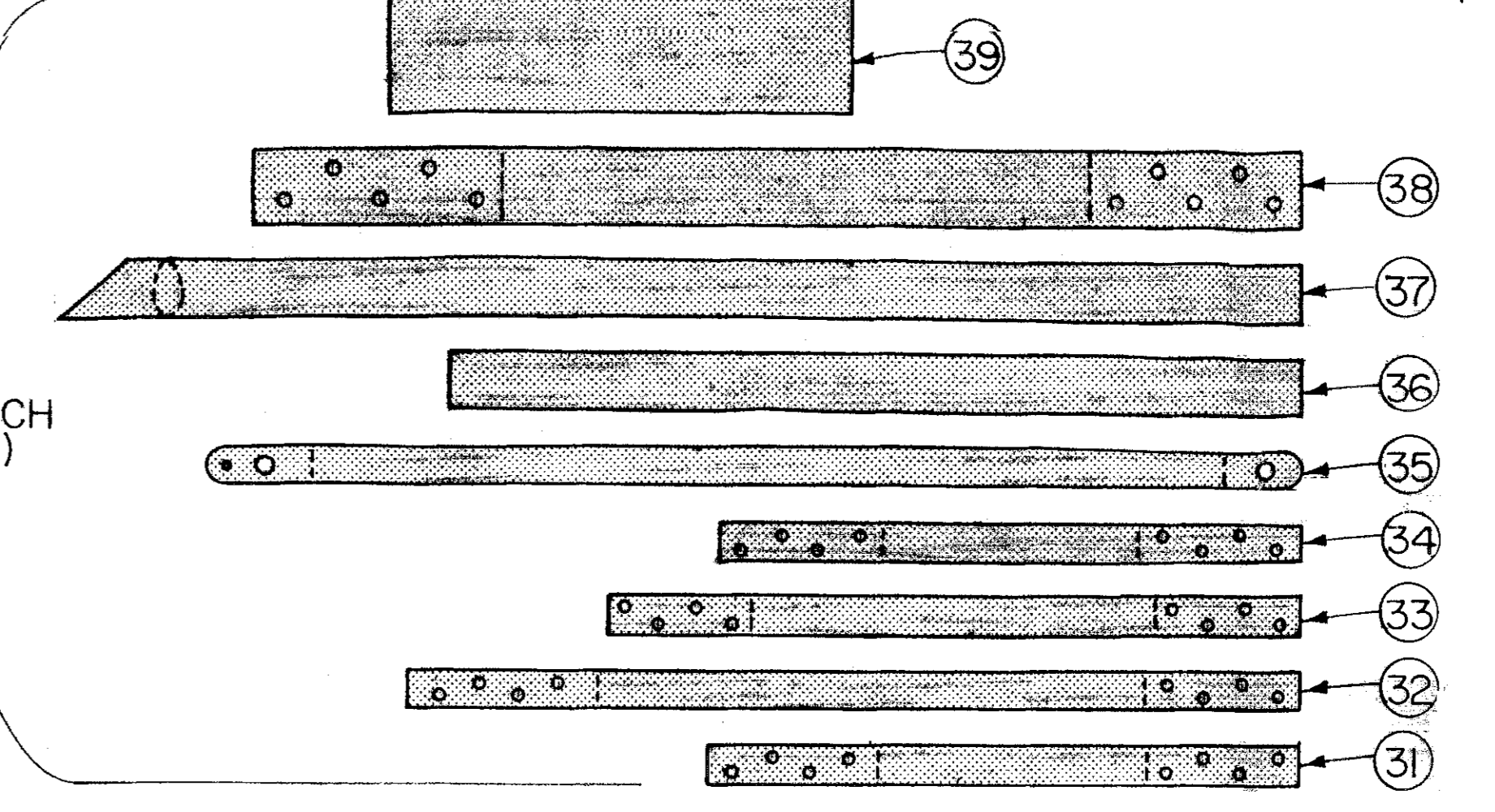
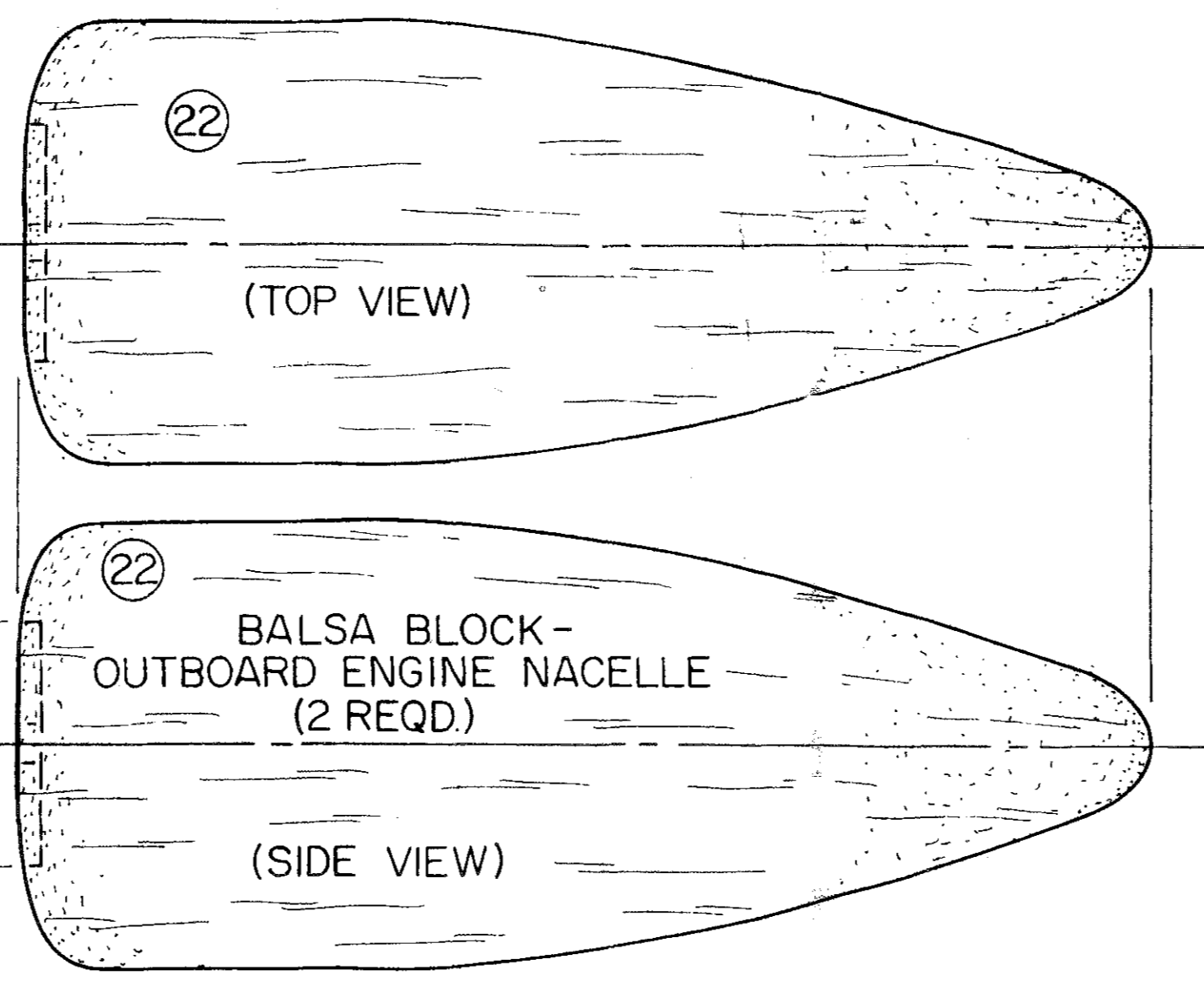
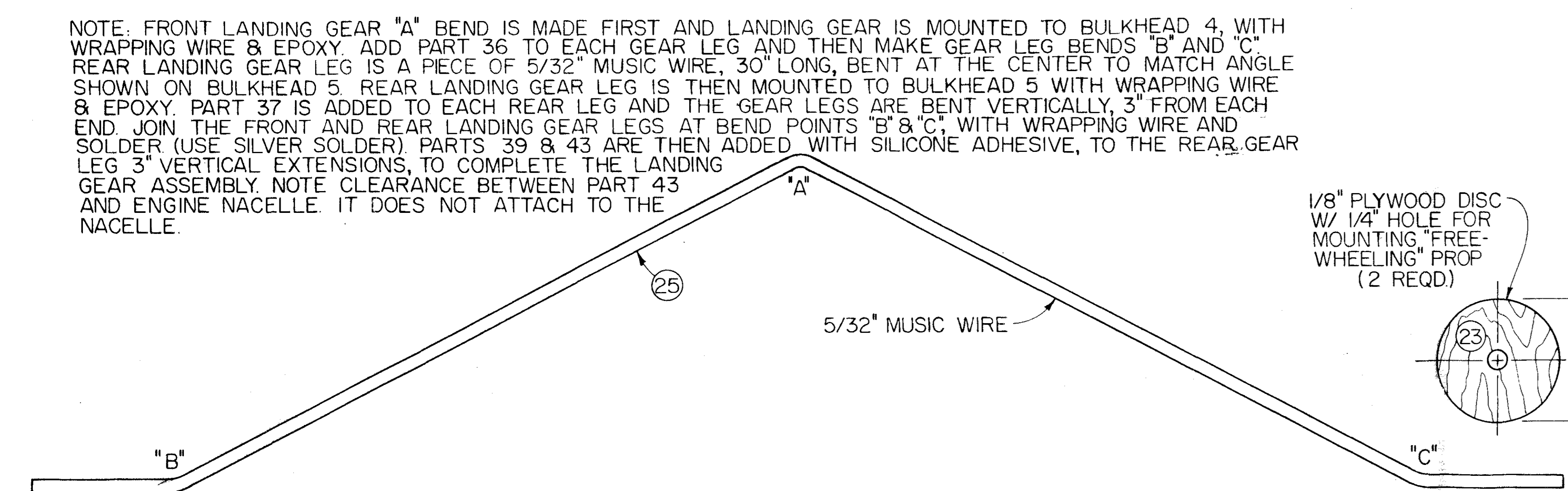
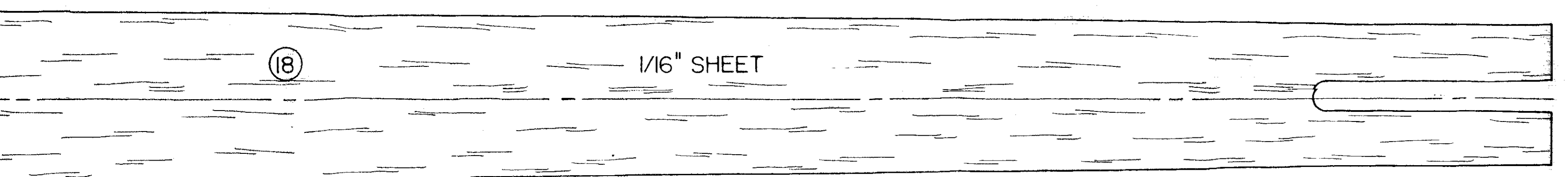

NOTE: PARTS 31 THRU 39 ARE CUT FROM K & S STREAMLINE TUBING. 31 THRU 35 ARE 1/4" TUBING, 36 & 37 ARE 3/8" TUBING, 38 IS 1/2" TUBING, AND 39 IS 3/4" TUBING, WHERE INDICATED BY DASHED LINES AND GLUING PERFORATION HOLES; TUBING IS CRIMPED FLAT. 36 & 37 WILL FIT TIGHTLY OVER THE 5/32" LANDING GEAR WIRE.

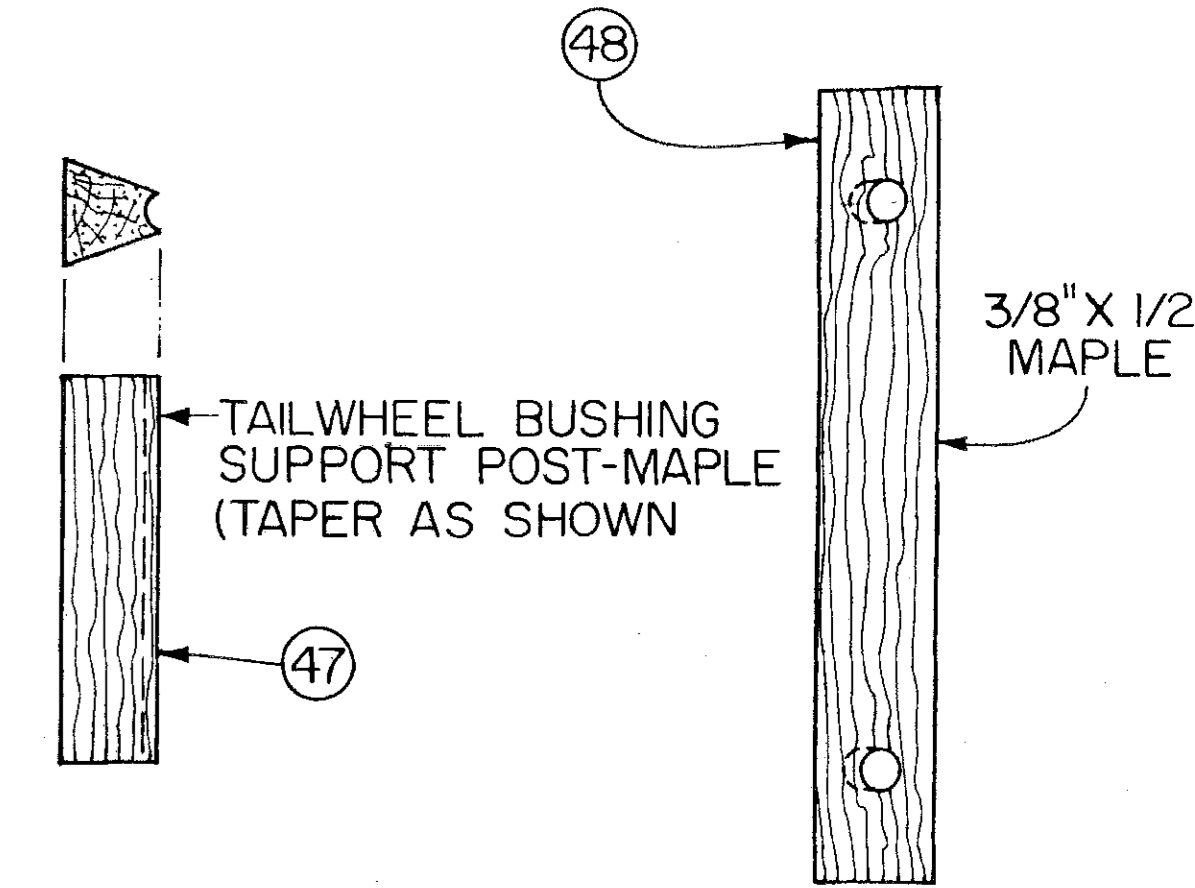
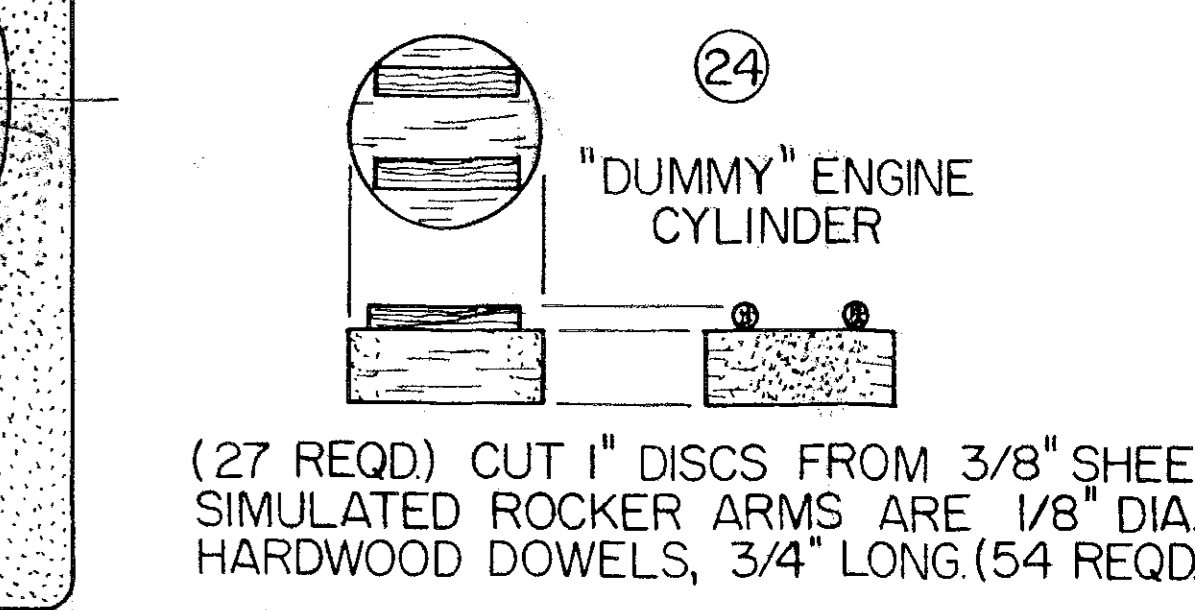

FORD TRIMOTOR

A 1/12 SIZE SPORT SCALE DESIGN

DESIGNED & DRAWN BY STU RICHMOND

PLANS BY Bob Wallace

SHEET 3 OF 3