

TRAINER SERIES

Instruction Manual

TRAINER TWENTY

TRAINER FORTY

TRAINER SIXTY

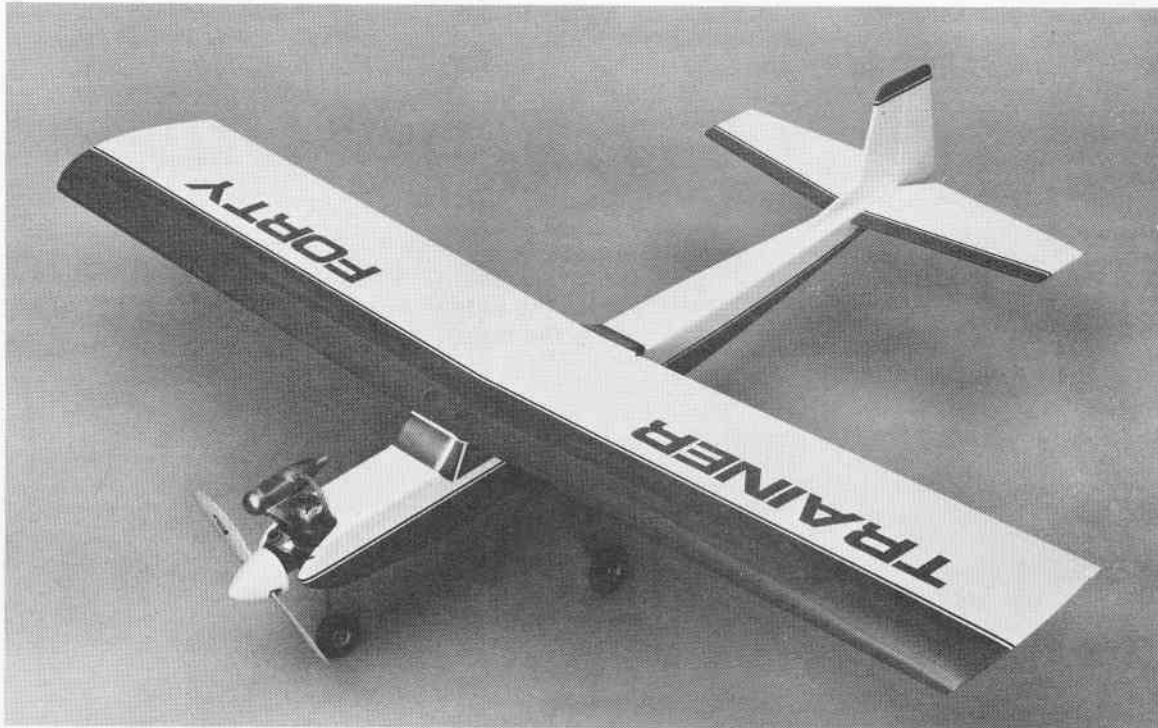

There's no better place to start than one of Great Planes' Trainers when it comes to building your first R/C model airplane. These Trainers are extremely easy to build. The machine cut and sanded parts go together fast and accurately. And accuracy is important when building a model; you need a straight wing and fuselage to assure that the model flies straight and true. The design of the Trainer with its large wing area and long tail moment offers stable flight which is very important when learning to fly. We urge you to build on a *flat* surface so you will end up with a model with no warps or twists.

This photo instruction book will take you through step by step from start to finish. It is suggested that you read through these instructions and identify and mark the parts before you begin assembly. Refer to the plans and parts list for actual sizes of parts and materials needed to finish your model, whether it is the Trainer Twenty, Forty or Sixty.

Use the plans as a *guide only* as the paper they are printed on has a tendency to change size with moisture. Use the parts themselves as they are self aligning and will fit together accurately.

TRAINER	20	40	60
Engine	.15-.25	.25-.45	.45-.61
Wing Span	52½"	59"	65"
Wing Area	473 sq. in.	634 sq. in.	764 sq. in.
Length	40½"	46½"	51½"
Weight	3½ - 4 lbs.	4½ - 6 lbs.	6½ - 8 lbs.

Materials Needed to Complete the Trainer:

4 channel radio	Spinner	White glue
4 Engine mounting bolts	Propeller	Engine
Fiberglass cloth/resin	Epoxy	Covering
2 5/32" wheel collars	Instant glue	Hand tools
		3 wheels
		Fuel tank

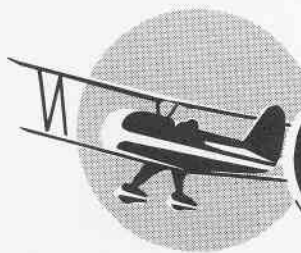

GREAT PLANES

MODEL MANUFACTURING COMPANY

URBANA, ILLINOIS 61801

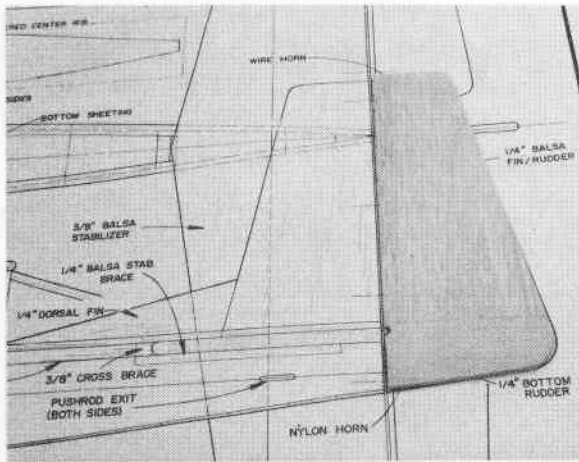

A. BUILDING THE TAIL SECTION

1. Trial fit the Rudder and Rudder Bottom piece. Sand if necessary for a good fit. Glue these pieces together. Sand or cut a notch in the leading edge (front) of the rudder for elevator torque rod clearance. See the plans for location.

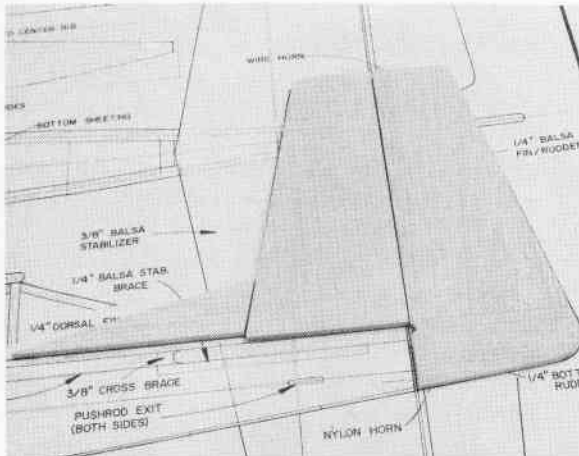

2. Locate the Fin (same shape as the rudder) and Dorsal Fin. Trial fit these pieces to each other and trial fit the fin to the rudder. Sand if necessary for a good fit. ★ Do not glue the dorsal fin to the fin yet!

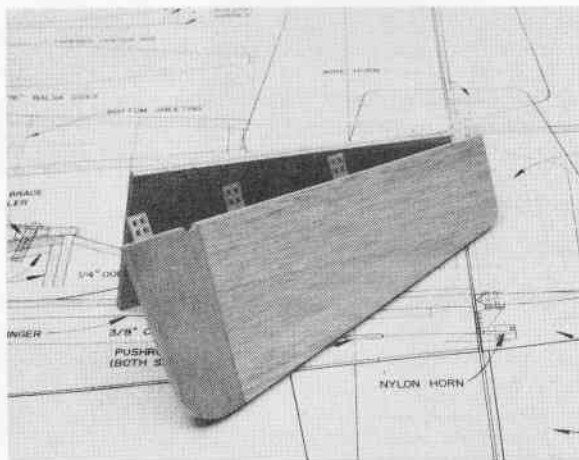

3. Now for the hinge slots. First draw a centerline down the leading edge of the rudder and the trailing edge (rear) of the fin. Find the 4 hinge locations for the rudder and the 3 hinge locations for the fin on the plans. Note that the bottom hinge location on the rudder is below the rudder horn location. Mark these locations on the fin and rudder edges. Cut the slots. There are good hinge cutting tools at your hobby shop or you can use an X-acto knife to do the job. Trial fit the hinges in all the slots. You will have to cut the bottom slot in the fuselage later for the bottom rudder hinge.

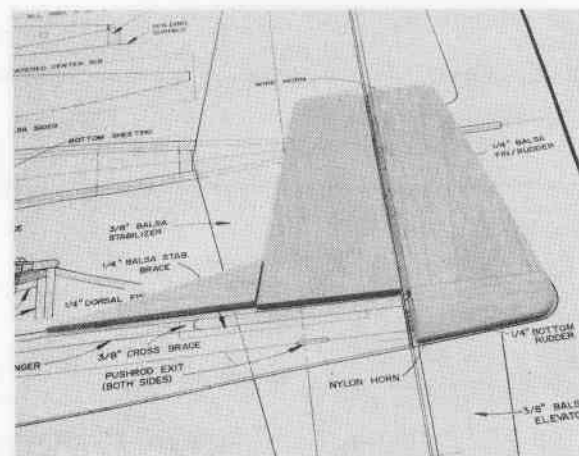

4. Now sand the leading edge of the rudder to a "V". Sand the other edges of the rudder, fin, and dorsal fin to the rounded shape shown on the plans. ★ Leave the trailing edge of the fin as is! Do not round!

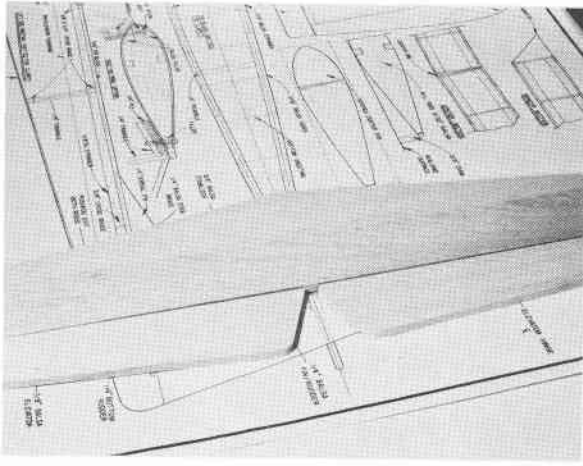

5. Trial fit the front and rear Stabilizer pieces. Sand if necessary for a good fit. Glue the two stabilizer sections together on a flat surface. Sand both sides of the stabilizer and elevator halves.

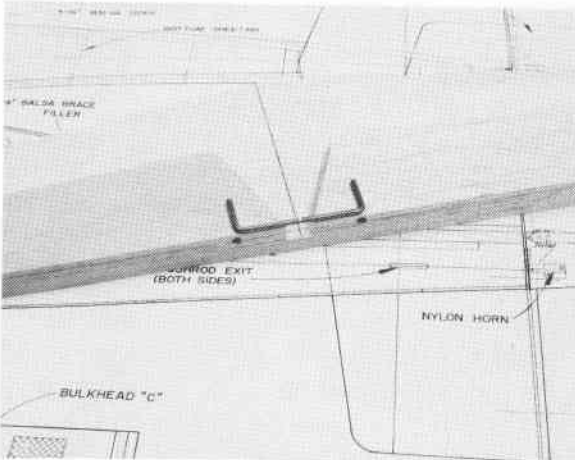

6. Draw a front-to-back centerline down the top side of the stabilizer and a centerline down the leading edges of the elevator halves. Mark the center of the elevator joiner. Align (line up) the stabilizer, elevator and elevator joiner and mark the hole locations for the joiner arms on the centerline of the elevator leading edge. Drill the holes using a 1/8" drill being careful to keep the drill centered in the sheet and perpendicular to the hingeline.

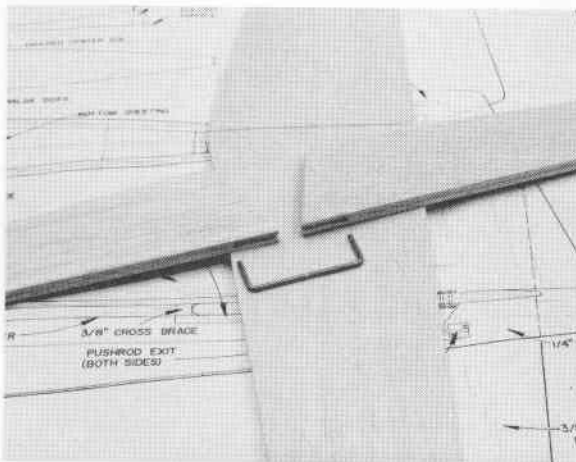

7. Cut a groove in the elevator leading edge inboard (inside) of the hole so when the joiner is installed it will be flush with the leading edge of the elevator.

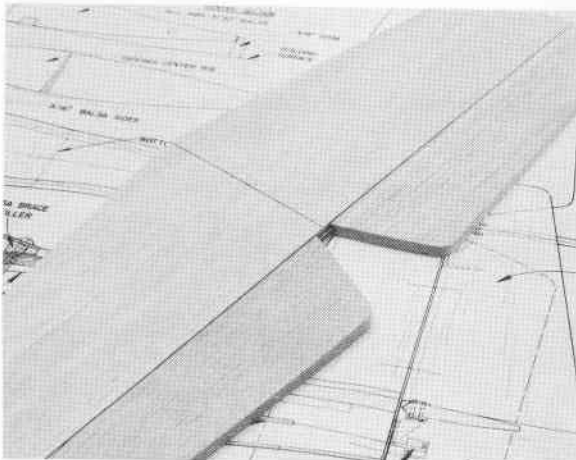

8. Temporarily install the joiner into the elevator halves. Check to make sure that this assembly is aligned properly. There should be no twist in the elevators. Line the elevators up front-to-back and side to side. Bend the joiner arms if necessary for a perfect fit. *Do not glue the joiner to the elevator halves until after the pieces are covered and /or painted.

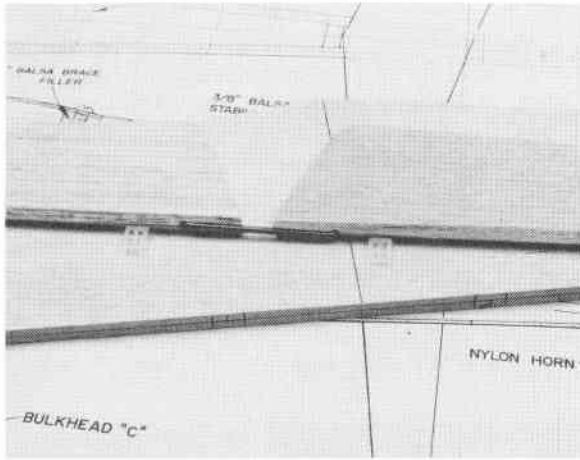

9. Mark and cut the hinge slots for the stabilizer and elevator halves as you did with the fin and rudder. See the plans for locations. There are 3 hinges on each elevator. Shape the leading edges of the elevator halves to a "V". Sand the stabilizer and elevator halves to the rounded shape shown on the plans. ★ Leave the trailing edge of the stabilizer as is. Do not round!

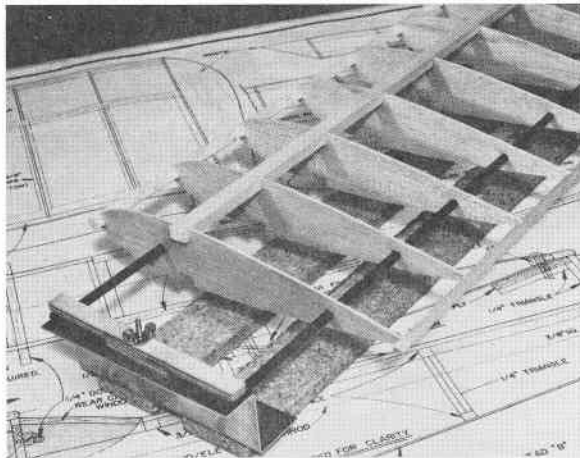

B. BUILDING THE WING PANELS

1. You have a choice of building the wings on a flat surface or on a wing jig as shown in this photo. The jig holds the ribs in place and the other parts are glued on the ribs. If you choose the wing jig method follow the order of the steps below as they are the same for either method. Following are the instructions for building one panel on a flat surface. Repeat the instructions for building the second panel or build them at the same time.

★ Be careful to build one right hand panel and one left hand panel. The only difference is that the servo cut-out in rib #1 is up in the left hand panel and down in the right hand panel as you build. The wing ribs are fully symmetrical so they have no top or bottom!

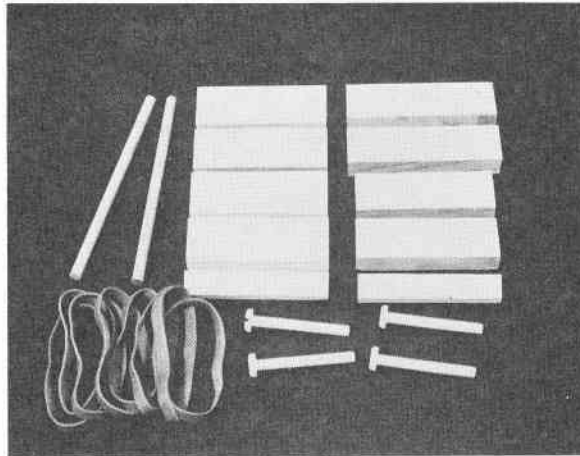

2. ★ Special Note: This trainer can be built with the wing attached to the fuselage by rubber bands to dowels or by bolts attached to hold down plates. Use the rubber bands for training and the wing bolts for advanced maneuvers. Decide now which way you will build your model. The photographs in the rest of the instructions will show the parts for both methods installed. The instructions for installing the wing bolt option are in *italics*.

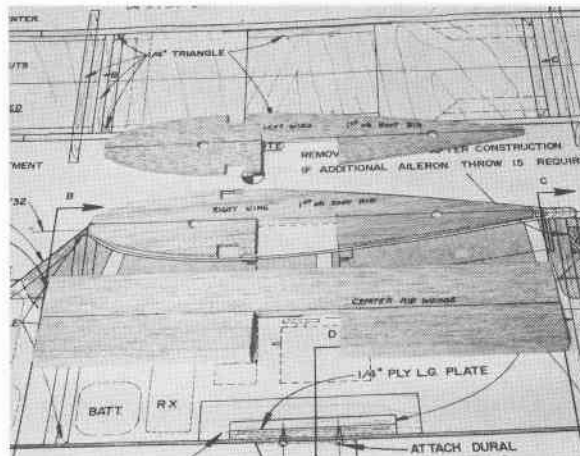

3. To make building easier later, cut out slots in the first or root rib (the one closest to the center rib wedge) of each wing and the center rib wedge for the aileron servo well. See the wing side view in the fuselage for approximate servo location in the wing. Draw centerlines on the ribs to get the location of the cut out the same on all 3 ribs.

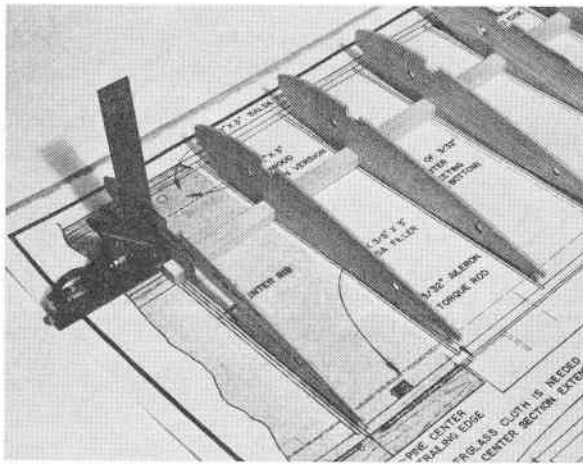

4. Pin the Bottom Spar(notches up) on a flat surface. Temporarily position the ribs in the notches. Make sure they are 90° to the building board. Make sure the cut out in rib #1 is down. Do not glue yet.

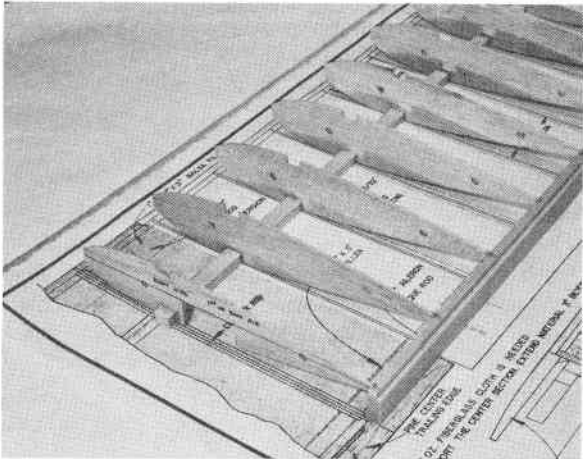

5. Position the Trailing Edge on the ends of the ribs. Use the shim (brace) to support the trailing edge. Glue the trailing edge to the ribs. Also glue the ribs to the bottom spar. Use the shim to keep the trailing edge straight and parallel to the building board when building both panels.

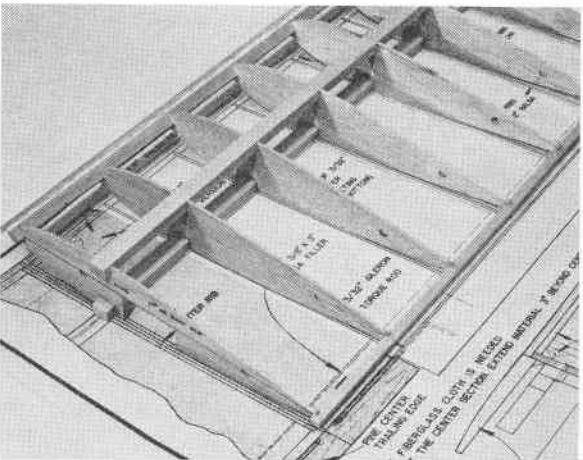

6. Position the Leading Edge on the ribs by placing the ribs in the notches. Glue the leading edge in position. Position the Top Spar (notches down) on the ribs. Glue in place.

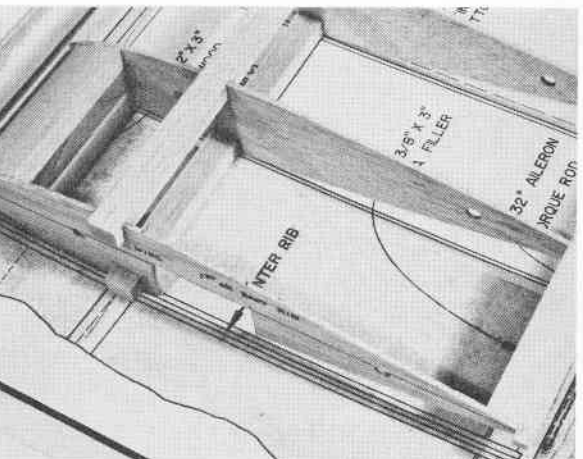

7. Trail fit and glue in the hardwood block (for bolt on wing) between ribs 1 and 2 at the leading edge. Glue in balsa filler blocks above and below the hardwood block. Also glue the balsa filler between ribs 1 and 2 at the trailing edge. See the "Bolt on Wing Option" side view on the plans for locations. Sand the filler blocks to the contour of ribs 1 and 2.

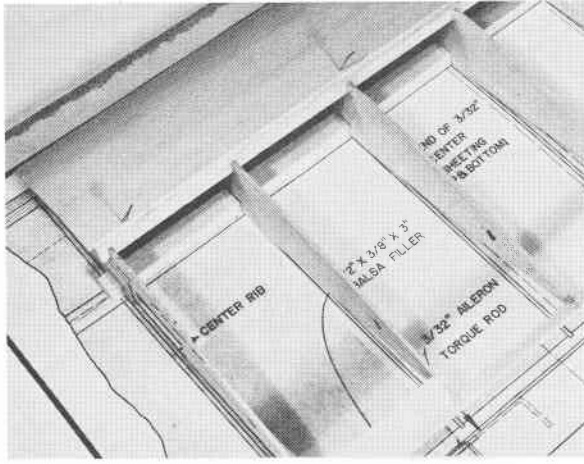

8. Glue the Top Leading Edge Sheeting in place. Glue the sheeting to the leading edge first. Let it dry. Then glue the sheeting to the ribs, filler blocks and spars. You can wet the top of the sheeting with a solution of half water and half ammonia to get the sheeting to bend easier. Then you can glue it all at once.

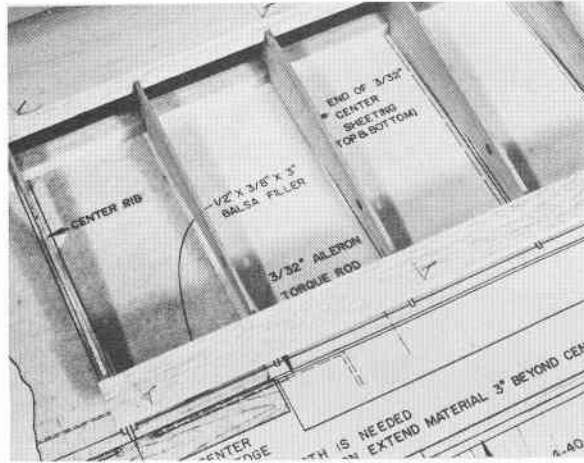

9. Glue the Top Trailing Edge Sheeting in place. Sand the trailing edge piece to the contour of the ribs first. Glue the sheeting to the ribs, filler blocks and trailing edge. Align the sheeting flush with the rear edge of the trailing edge.

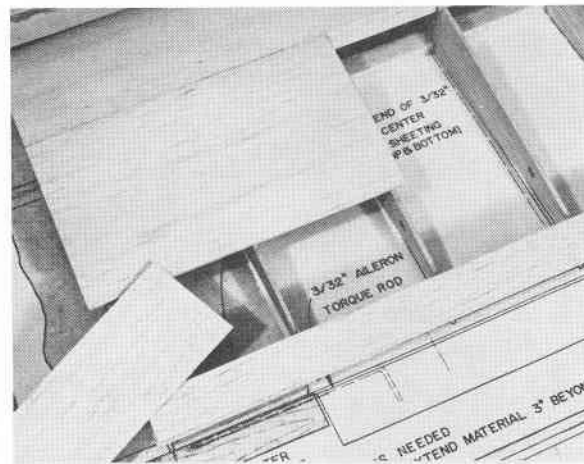

10. Glue the Top Center Section Sheeting to the wing panel. Start by gluing the top piece to the wing. Cut the second piece to fit and glue it in place. Make sure the center sheeting is glued to the ribs, top spar, leading edge sheeting and trailing edge sheeting.



11. Cut Cap Strips from the long strip stock provided to fit over the ribs between the leading and trailing edge sheeting. Use the wing itself and not the plans as a guide for measuring the lengths of the capstrips. Glue the Top Cap Strips in place.

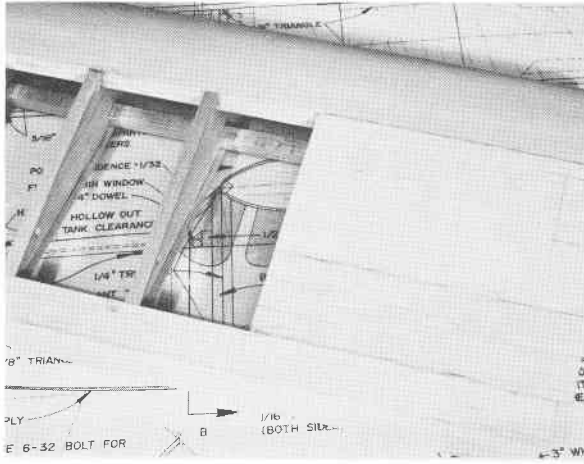

12. □ Turn the wing over. Glue on the Bottom Leading Edge Sheeting, the Trailing Edge Sheeting, Center Section Sheeting and cap strips as you did on the wing top. Glue the center sheeting over the cut out you made earlier. Mark the location of the cut out on the center section sheeting. You will cut this out later for the aileron servo well.

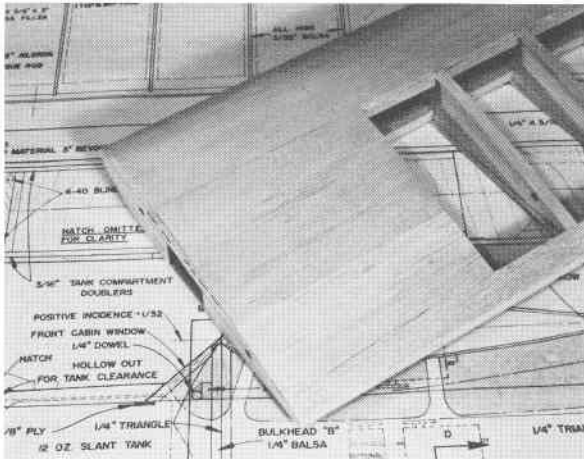

13. □ Trim off excess wood at each end of the wing even with the ribs. Sand the leading edge to the shape shown on the plans. Sand all joints and sheeting smooth. Build the other wing panel the same way if you haven't done so already changing only rib #1 position as stated in Step 1 of "Building the Wing Panels". Remember that you want to build one right hand panel and one left hand panel.

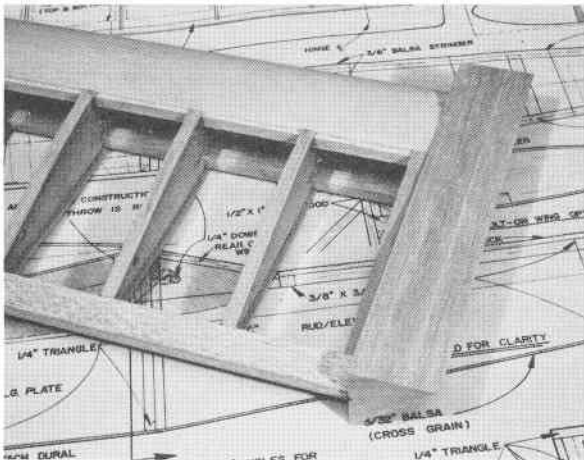

14. □ You now have a right and a left wing panel. Lay the wings on your work surface so the bottoms are down. Draw a centerline down the length of the inside of the wing tip and a centerline down the center of the tip rib (last rib) to help align the tip parallel to the wing. Glue the wing tip to the tip rib. ★ Note that the wing tip comes straight out from the top of the wing. Position both wing tips exactly the same so you will have the same shapes after you sand.

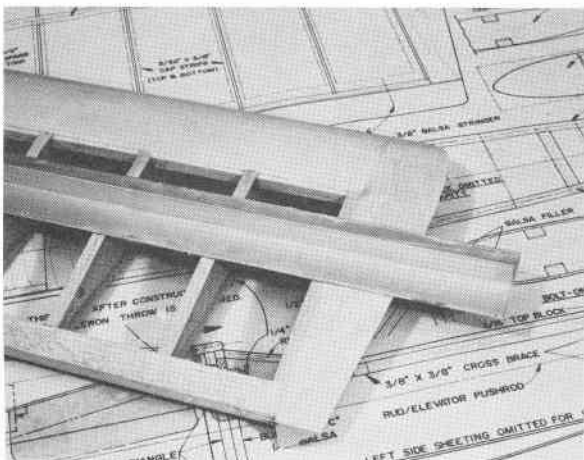

15. □ Carve the wing tip to shape making sure the tip is oversize. Then final sand to shape. Use a sanding block or sanding "T". Hold the block even with the top of the wing to get the top contour when you sand.

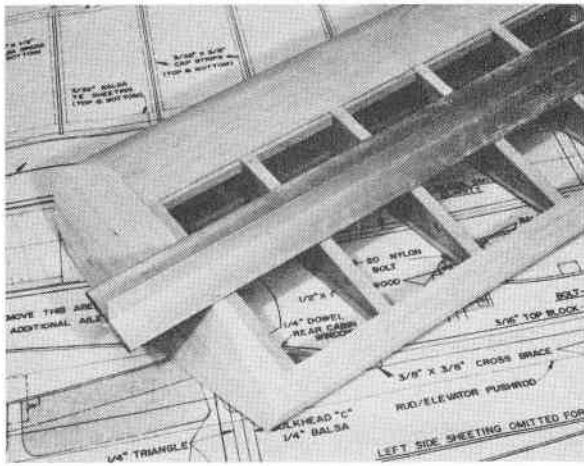

16. □ Hold the sanding block even with the bottom of the wing to get the bottom contour. Wing tip will automatically become the correct shape if the sanding block is held in this manner.

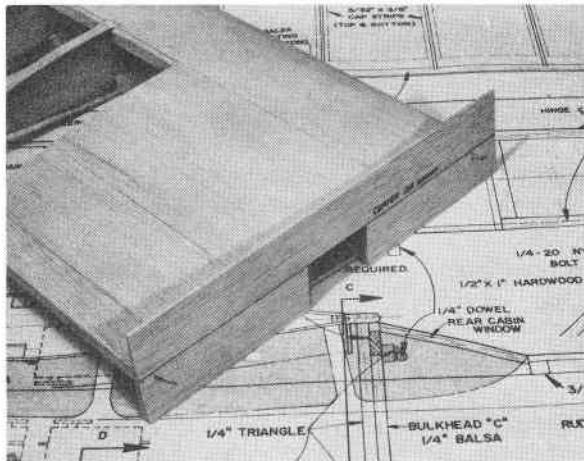

C. JOINING THE WING PANELS

1. □ Lay the left wing panel on a flat surface, top side up. Place the center rib wedge next to rib #1 (root rib), the wider edge of the wedge down. Glue the wedge to the rib using 5 minute epoxy. Center the wedge on the rib.

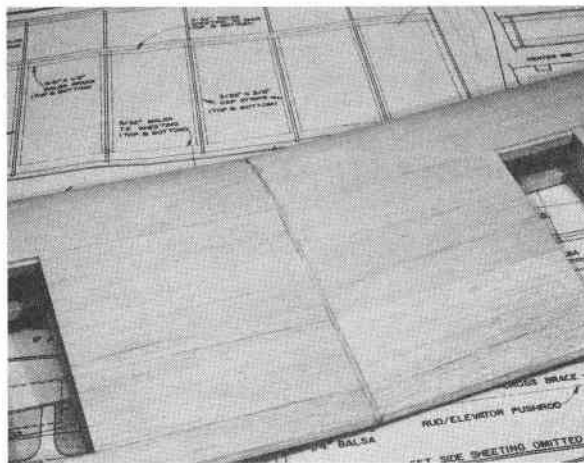

2. □ Rough cut the wedge to shape leaving it oversize around the rib. Shim up each wing tip for proper dihedral (angle of wing). See the dihedral drawing on the plan. Make sure the wing panels are aligned properly. Measure from the wing tip leading edge to the work surface and from the wing tip trailing edge to the work surface to make sure the wing is not twisted. Glue the right wing panel to the left wing panel using slow set (15-30 min.) epoxy. When dry, finish sanding the center rib.

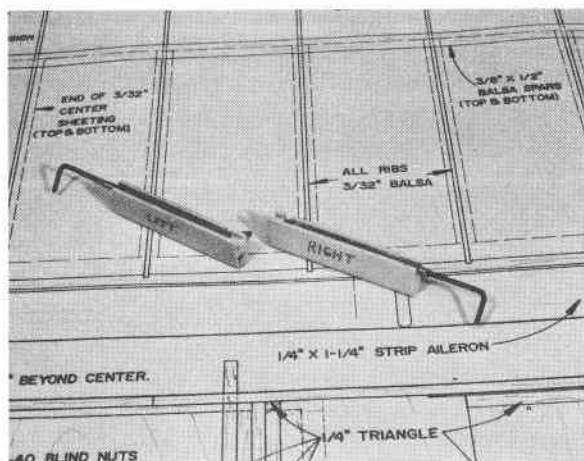

D. INSTALLING THE CENTER TRAILING EDGE

1. □ Cut a notch in the bottom grooved edge of both Pine Center Trailing Edges $\frac{3}{8}$ " in from one end. Make right and left parts. This notch is for aileron torque rod arm clearance. Trial fit the torque rod in the precut groove. The long arm extends through the notch you cut. Glue only the brass sleeve of the torque rod to the center trailing edge. Use vaseline at the ends of the brass sleeve so only the sleeve is glued to the center trailing edge.

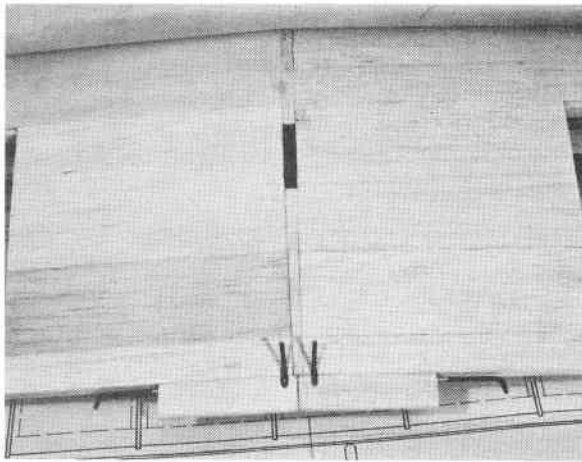

2. Draw a centerline down the length of the trailing edge of the wing. Trial fit the center trailing edges. Glue them with epoxy to the wing panels. Make sure the torque arms are on the same side as servo well cut-out marks. Bottom of wing is shown here. After the glue has dried, notch the trailing edge to allow the forward movement of each torque rod.

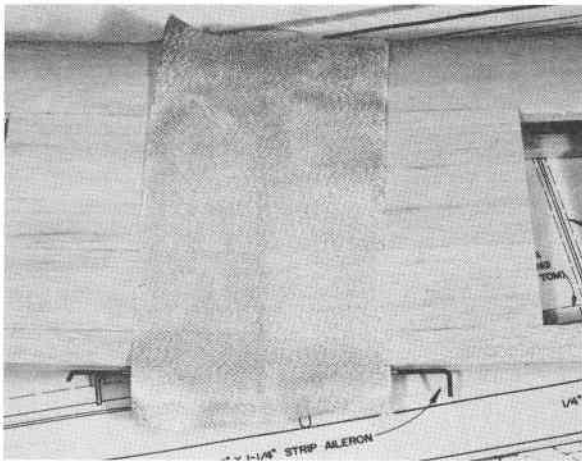

E. GLASSING THE CENTER SECTION

1. It is important that you glass the wing center section. Omitting these steps could result in a wing failure during flight and possibly a crash. Cut one piece of 4 or 6 oz. glass cloth to fit the wing center section. One piece of cloth 6" wide should be used. You may use one piece of cloth for the top and one for the bottom of the wing. Fill in the holes around the torque arms with wax drops from a burning candle so resin will not stick to the torque arms, which must be moveable for aileron control.

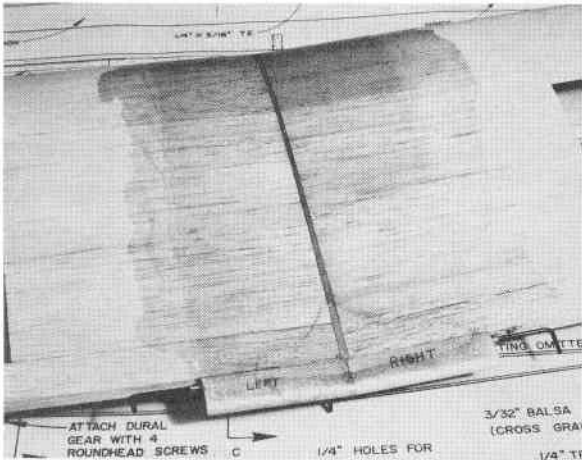

2. Apply a thin coat of polyester resin to the wing center section. Lay the cloth on the wing. Add more resin. Immediately squeegee off the excess. Let cure until dry. Sand the glass *lightly*. Brush on a second coat of resin and let it dry. Do both top and bottom of wing. Overlap the cloth slightly at the leading and trailing edges. Finish sand.

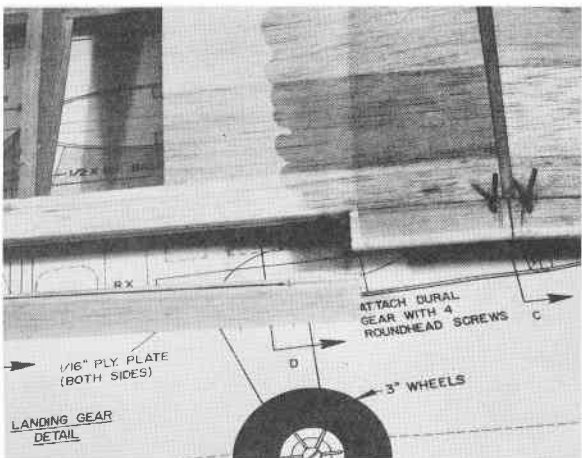

F. PREPARING THEAILERONS

1. Draw a centerline down the leading edges of the ailerons. Mark and drill the hole for the aileron torque rod. Cut a groove in the aileron for the torque rod clearance. Make right and left ailerons.

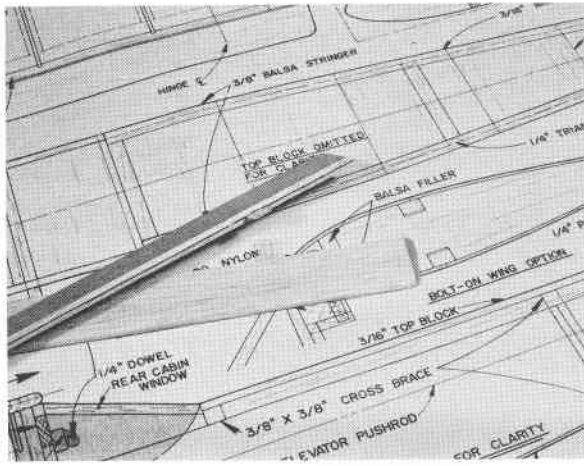

2. Mark the hinge locations on the trailing edge of the wing and the leading edges of the ailerons. Cut the hinge slots. Trial fit the hinges but do not glue them in until the model is covered later. Sand the ailerons to the contour shown on the plans. Lastly sand the aileron leading edge to a "V" as shown on the plans.

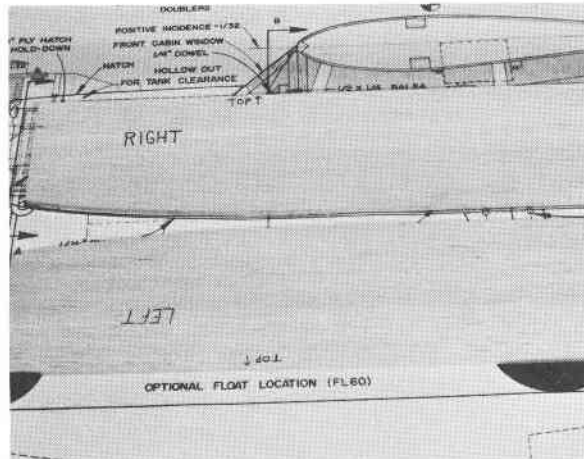

G. BUILDING THE FUSELAGE

1. Mark the insides of the fuselage sides "right" and "left". The flat side is the top of the fuselage. Mark the top also.

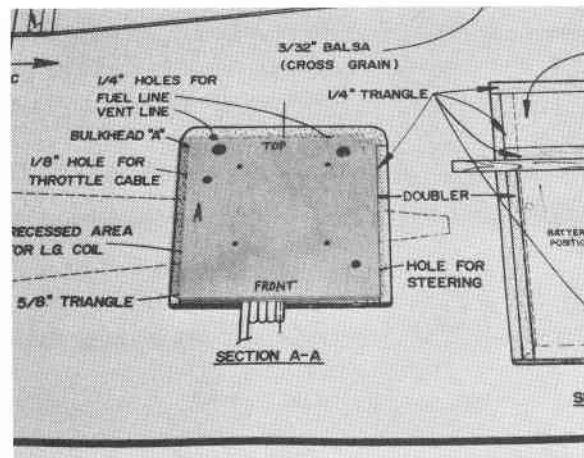

2. Locate Bulkhead A. Mark and drill the holes for the motor mount screws, throttle cable, steering cable, fuel line and vent line. (Bulkhead A is the same size as the landing gear plate.) Use these instructions if your engine is right hand throttle. If your engine is left hand throttle reverse the positions of the throttle and steering holes. Install 6-32 blind nuts in the holes you drilled for the motor mount.

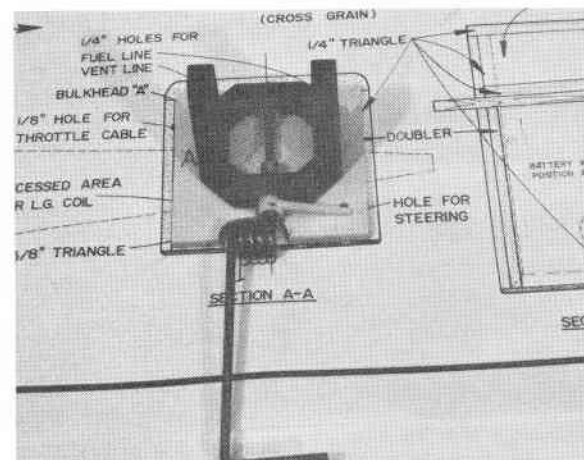

3. Relieve the area of Bulkhead A for nosegear coil clearance. Trial fit the nose gear/motor mount to Bulkhead A. Remove nosegear/motor mount.

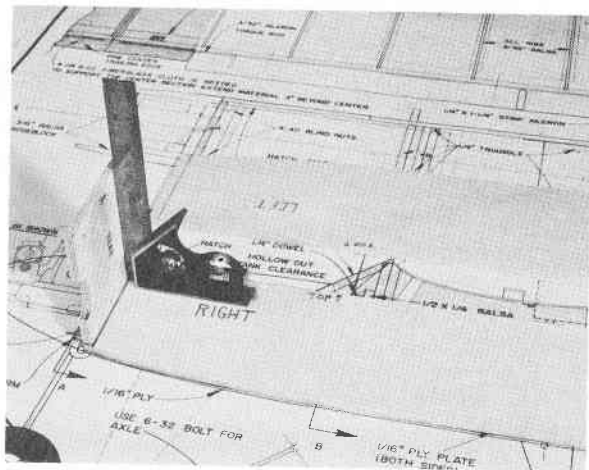

4. Mark the position of Bulkhead A on the inside of both fuselage sides by drawing a line $\frac{1}{4}$ " from the end of the fuselage side. Glue Bulkhead A to the right fuselage side making sure the bulkhead is 90° to the fuselage side. Use epoxy. ★Epoxy should be used whenever gluing plywood or hardwood pieces.

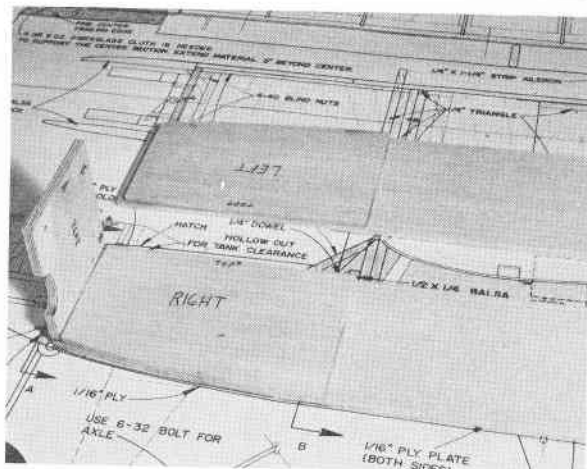

5. Trial fit and glue the balsa Tank Compartment Doublers behind Bulkhead A on the right fuselage side and even with Bulkhead A. Glue the doubler on the left fuselage side from the $\frac{1}{4}$ " line back toward the tail.

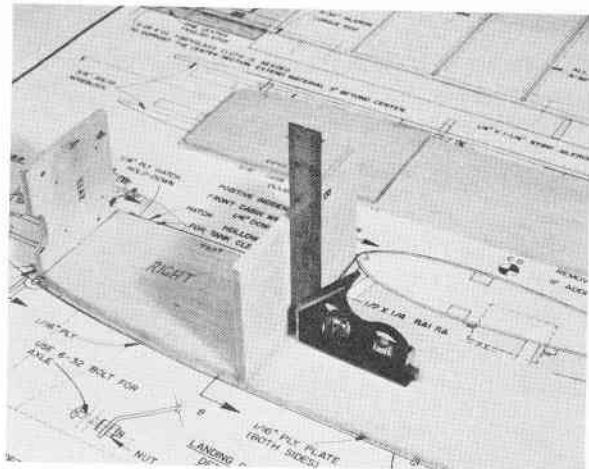

6. Drill pushrod holes in Bulkhead B. See plans for approximate location. Glue Bulkhead B to doubler and to the right fuselage side making sure it is 90° to the fuselage side. Bulkhead B fits right at the end of the tank compartment doubler.

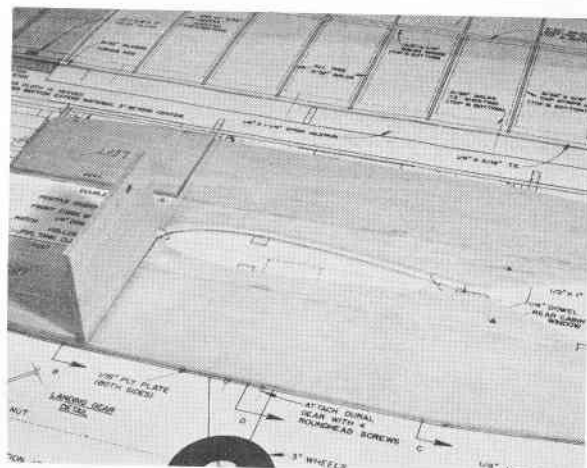

7. Locate the Cabin Sides/Wing Saddle pieces. Mark and drill the dowel holes. Find and mark position of cabin side by referring to plans. Small flat area at top of cabin side should align with bulkhead B. Glue cabin side to right fuselage side and bulkhead B. Glue the other cabin side to the left fuselage side making sure it is in the same position as the right cabin side.

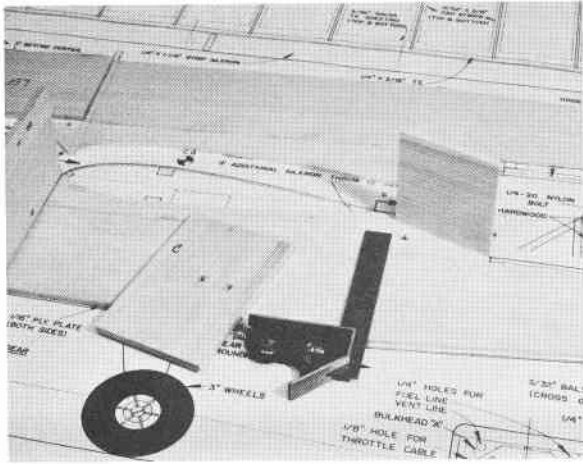

8. Mark and drill pushrod guide holes in Bulkhead C. Mark the position of Bulkhead C on both fuselage sides. Use balsa rear cabin window as a guide for location of Bulkhead C.

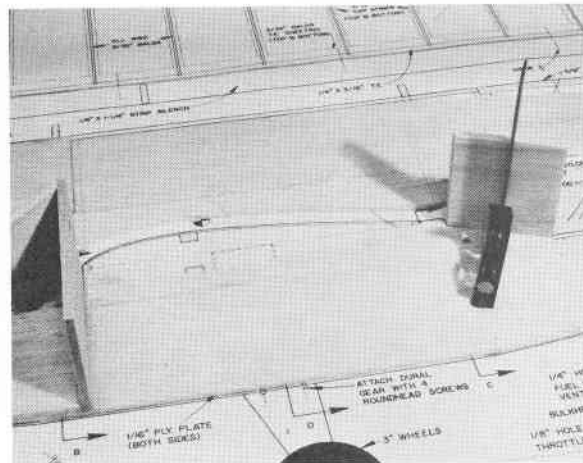

9. Trial fit the Front and Rear Cabin Windows to the right fuselage side. Glue the smaller front cabin window to bulkhead B and the right fuselage side. Glue the larger rear cabin window to the right fuselage side leaving room for bulkhead C. The cabin windows are glued to the inside of the fuselage side and even with the edge of the cabin side/wing saddle. Make sure the windows are 90° to the fuselage side.

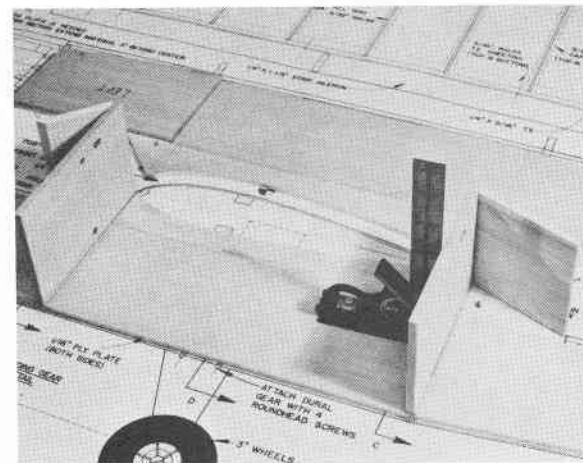

10. Trial fit and glue Bulkhead C to right fuselage side and rear cabin window making sure the bulkhead is 90° to the fuselage side. Use the lines you drew in step 8 earlier for alignment.

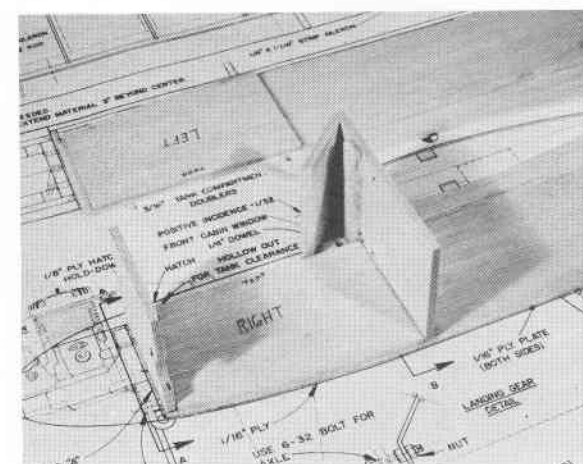

11. Trial fit and glue the 1/2" x 1/4" Balsa Dowel Spacers to the front of bulkhead B and the rear of bulkhead C. Check the plans for location. (Front dowel spacer is shown here.)

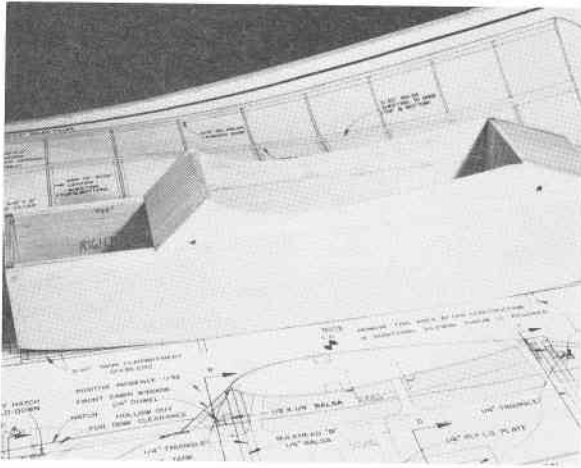

12. Stand the fuselage sides upright. Glue the Left Fuselage Side to the right fuselage side at Bulkheads A, B, C and the cabin front and rear pieces. Make sure the sides are aligned and 90° to the building board.

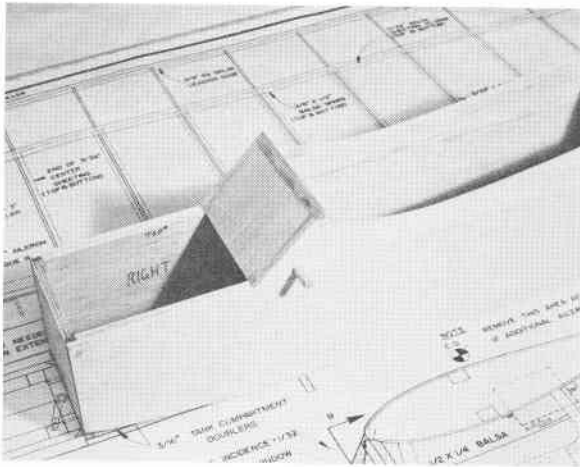

13. Cut and glue 1/4" triangle stock to the 1/2" x 1/4" braces. Glue the wing dowels to the triangle stock and braces. See the plans for location. Cut and glue the 1/4" triangle stock above bulkhead B. The triangle stock should follow the angle of the front cabin window. See the plans for location. You may have to sand this 1/4" triangle stock piece to the correct contour.

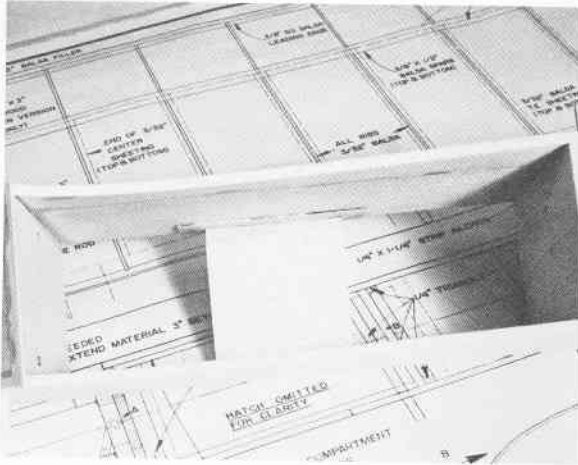

14. Glue in the 1/4" plywood Landing Gear Plate between the fuselage sides and flush with the bottom of the sides. See plans for location. Glue in the 1/16" ply plates on the fuselage sides above the landing gear plate. Cut and glue 1/4" Triangle stock braces to landing gear plate and 1/16 ply plate.

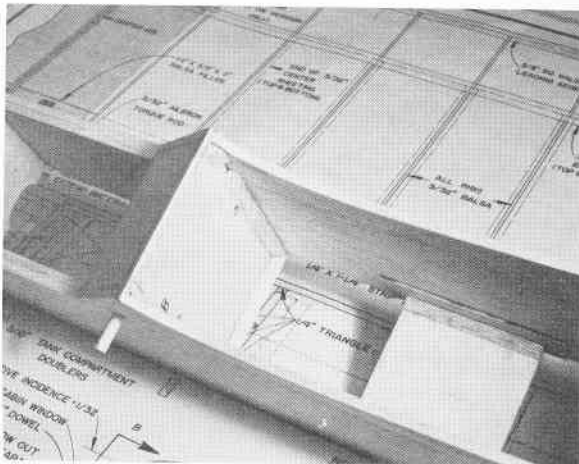

15. Cut and glue 1/4" Triangle Stock behind bulkhead B and in front of bulkhead C. (You will have to leave room for the hardwood block and plywood pieces for the wing bolts to be installed next. See the "Bolt on Wing Option" on the plans for location.) The triangle stock is glued across the bottom and up both sides of the bulkheads.

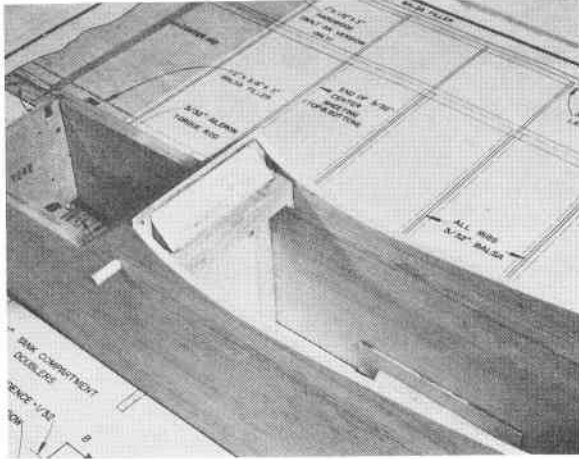

16. Glue in the $\frac{1}{2}$ " x 1" wing hold down block behind bulkhead B. Glue $\frac{5}{8}$ " triangle stock above the hardwood block. Glue 3 pieces of $\frac{1}{4}$ " triangle stock below the hardwood block. See the plans for location.

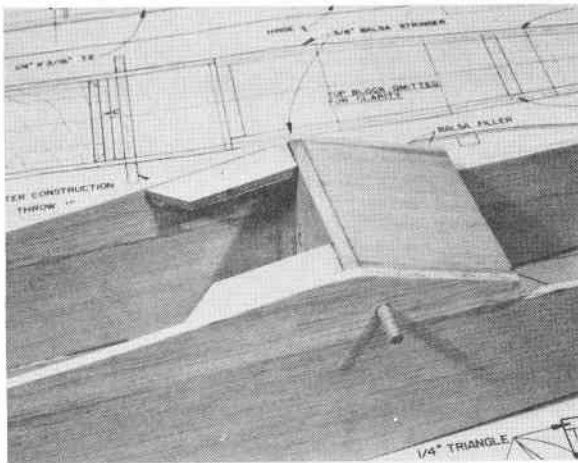

17. Glue the two $\frac{1}{4}$ ply rear wing hold downs to the front of bulkhead C and the fuselage sides. Glue $\frac{1}{4}$ " triangle stock under the hold downs along the fuselage sides for support. See the plans for location.

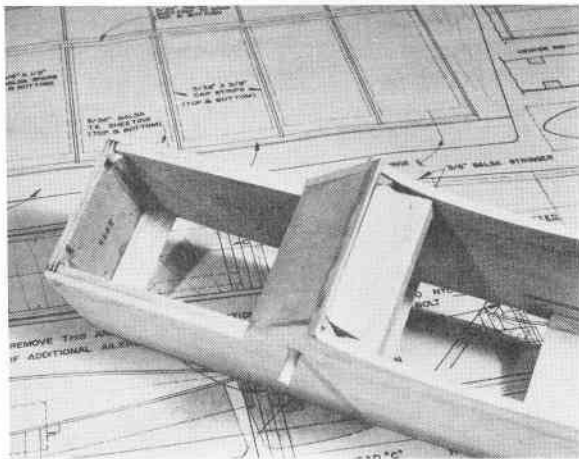

18. Glue $\frac{5}{8}$ " Triangle stock behind Bulkhead A at the bottom. Glue $\frac{1}{4}$ " triangle stock vertically along the sides behind Bulkhead A. You will have to leave room for the hatch hold down to be installed next. Also drill the $\frac{5}{8}$ " triangle stock for steering linkage clearance and drill the $\frac{1}{4}$ " triangle stock for throttle linkage clearance.

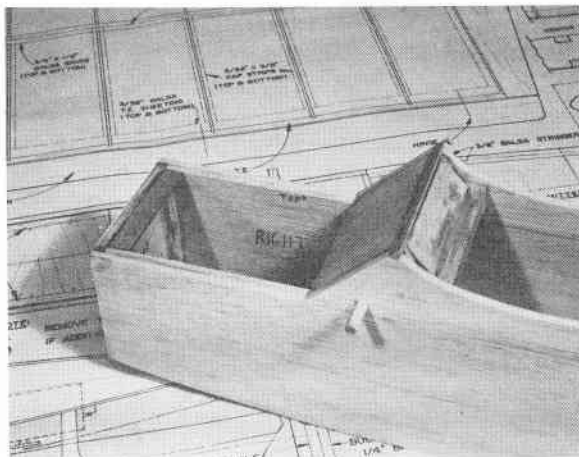

19. Glue in the Ply Hatch Hold Down behind Bulkhead A.

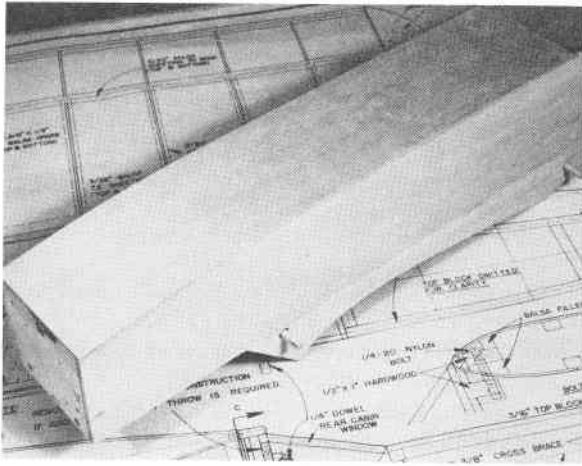

20. Sand the bottom of the fuselage and trial fit the plywood bottom. Glue the 1/16" plywood bottom to the fuselage from the middle of Bulkhead C to the front of Bulkhead A. The ply bottom overlaps the sides. Sand the ply bottom to the contour shown on the plans.

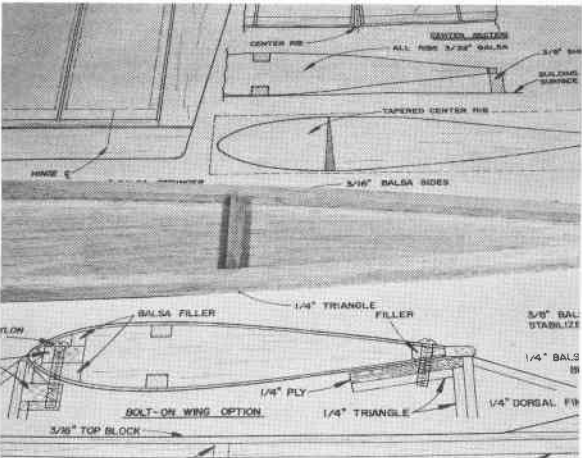

21. Lay the stabilizer on the Top Block and mark the stabilizer position on the top block. Glue the stringers and cross braces to the top block.

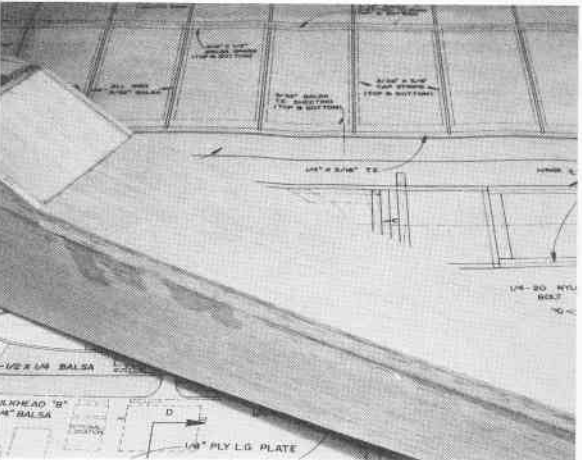

22. Glue the Top Block to the fuselage. Start gluing at the rear cabin window and work your way back toward the tail. Glue the fuselage sides together at the tail. Sand the Top Block to the fuselage contour. Round the edges slightly.

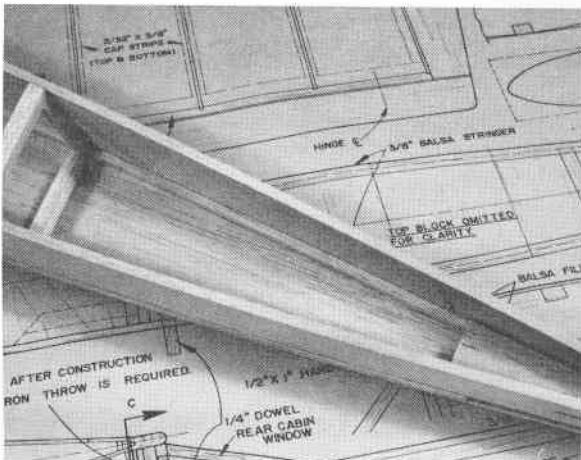

23. Glue in the Balsa Stabilizer Brace. See plans for location. Use epoxy and work from bottom of fuselage opening. Use wax paper over the stabilizer and use the stabilizer as a spacer when gluing the brace if necessary. Add the brace across the bottom of the fuselage and the vertical braces on the fuselage sides.

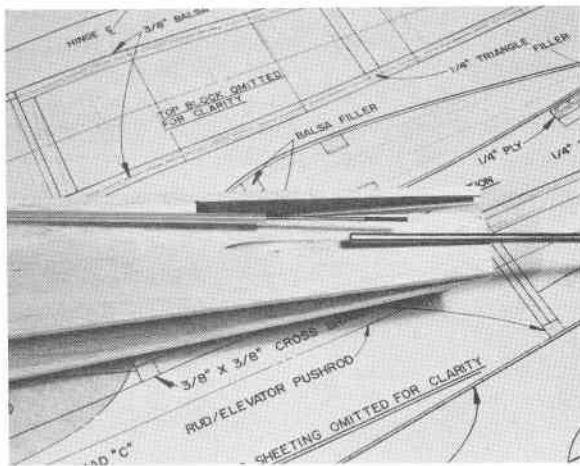

24. Mark and drill the holes for the pushrod exits for the rudder and elevator. A brass tube sharpened internally with an X-acto knife makes a neat, clean angled hole for tube-style pushrod housings. You may install tube in a tube pushrods or wire in a tube as shown here.

NOTE: Cut the plastic pushrod housings so you have two pieces, one 29" long and one 7" long. Use the longer pieces for the elevator and rudder pushrod housings and the shorter pieces for the throttle and steering pushrods. Trim the housings if they are too long after trial fitting and gluing in place.

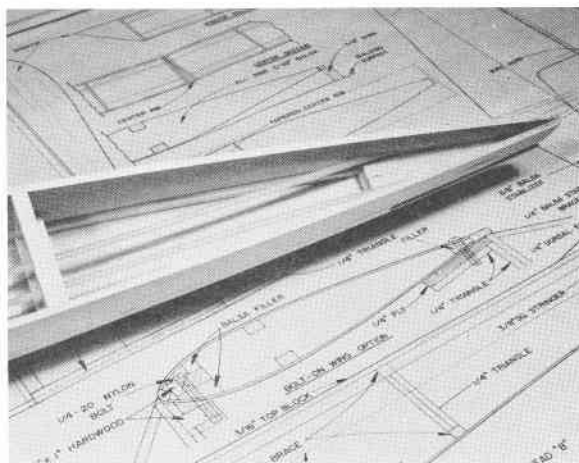

25. Install pushrod outer housings through the exits and through the holes you drilled in bulkhead C. Leave the housings long enough in the servo compartment to reach the servos. Carefully plan the routing of both tubes so they will remain as straight as possible. (See the plans). Trim the pushrod housings at the exits after you instant glue or epoxy them in place. If you sand the areas to be glued on the housings first, the glue will stick better. Brace the housings midway between the tail and Bulkhead C.

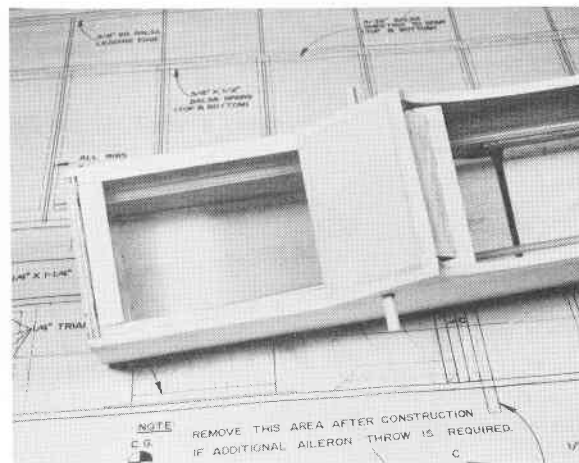

26. Install the two shorter plastic tubes for the throttle and steering linkage. Instant glue or epoxy in place as you did with the elevator and rudder pushrods.

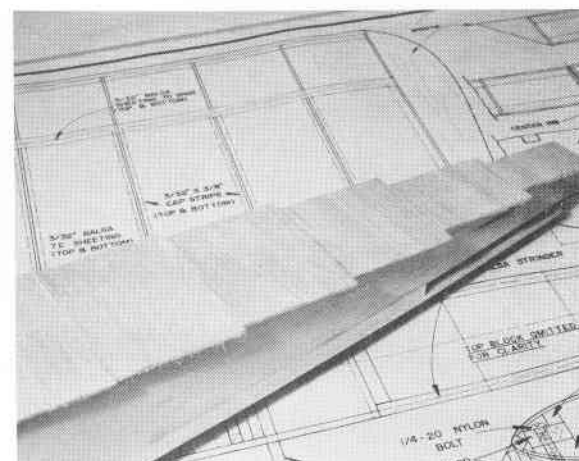

27. Cut the Bottom Sheeting to lengths to fit cross grained across the fuselage bottom. See the plans for approximate lengths. Glue the bottom sheeting in place by starting at the plywood bottom and working your way back to the tail. When the glue is dry, trim the bottom sheeting and sand to shape.

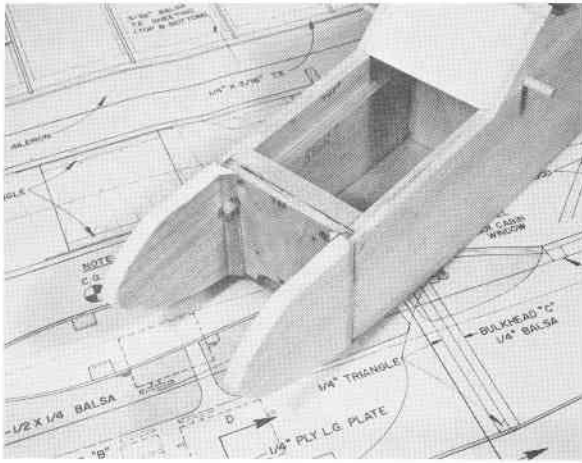

28. Glue the Front Nose Pieces to the front of Bulkhead A and the fuselage sides. Make sure the flat side of the nose piece is up when the fuselage is upright. Glue the Vertical $\frac{1}{4}$ " triangle stock in front of bulkhead A. Trim the $\frac{1}{4}$ " triangle stock for linkage pushrod housings clearance. Also fuelproof the front of the firewall and the inside of the nose pieces with polyester resin.

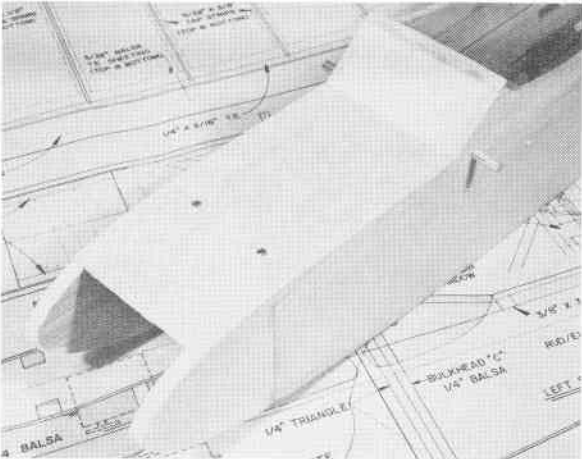

29. Glue the Rear Hatch Hold Down to the bottom of the hatch making sure it extends $\frac{1}{4}$ " or so beyond the end. Place the hatch on the fuselage. Mark and drill 2 pilot holes for 4-40 screws and blind nuts through both the hatch and the front hold down in the fuselage. Redrill the holes in the hold down for the blind nuts. Install the blind nuts in the hold down. Install the hatch. Do not glue! Sand the hatch to the fuselage contour. Remove the hatch.

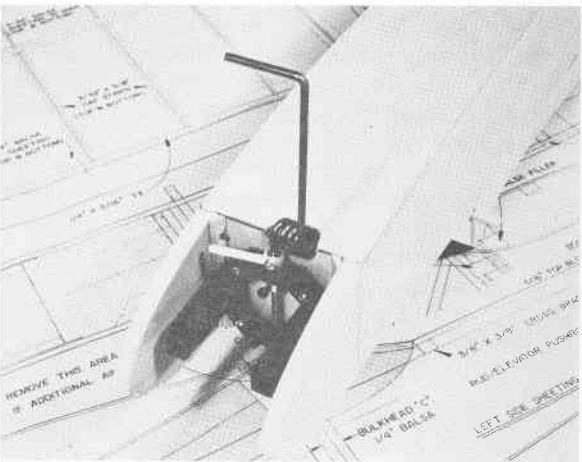

30. Trial fit the motor mount/nosegear assembly to the front of bulkhead A. You will have to relieve (cut out) the $\frac{5}{8}$ " Triangle Stock and plywood bottom for nosegear coil and steering arm clearance. Reinstall the motor mount/nosegear to check your work.

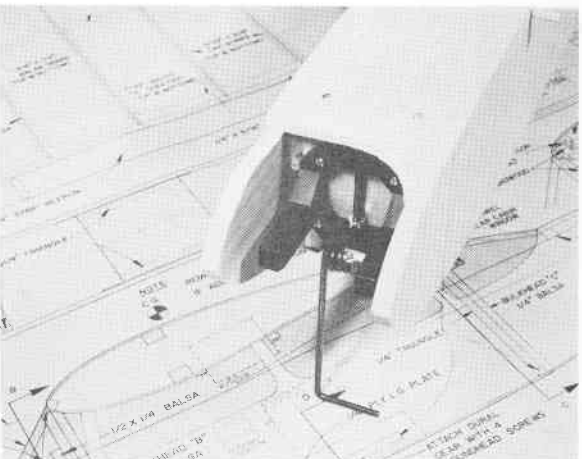

31. Trial fit the engine on the motor mount. You will have to relieve the hatch for engine clearance. Sand the hatch around engine. Mark and drill the holes for the engine mount bolts. Trial fit the engine and then remove the engine and motor mount assembly and hatch. (Socket head bolts are a good way to mount the engine.)

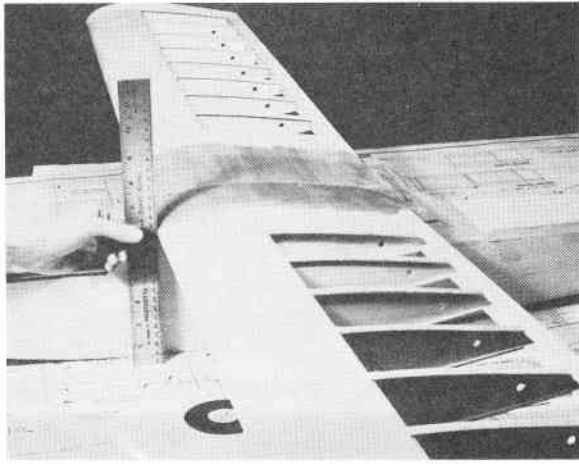

32. Place the wing in the saddle. Make sure the wing has a positive incidence of $+1/32"$. With the model upright on a flat surface measure from the leading edge of the wing to the building board and from the trailing edge of the wing to the building board. The leading edge distance should be $1/32"$ longer than the trailing edge distance. Center the wing on the fuselage making sure the trailing edges of the wing tips are the same distance from the tail of the fuselage, insuring proper wing alignment.

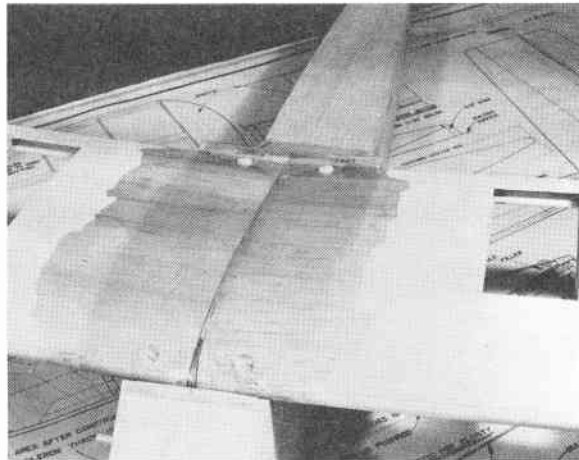

33. With the wing still in the wing saddle, drill $3/16"$ pilot holes for the wing bolts through the wing and hold down in fuselage (2 holes near the leading edge and 2 holes near the trailing edge). Drill the holes at the trailing edge at an angle so the bolt will rest flat on the trailing edge sheeting. Countersink the holes in the leading edges and redrill $1/4"$ clearance holes through the hardwood hold down block in the wing. Tap the holes in the fuselage hold downs for $1/4-20$ bolts. Trial fit the wing and leave in place for now.

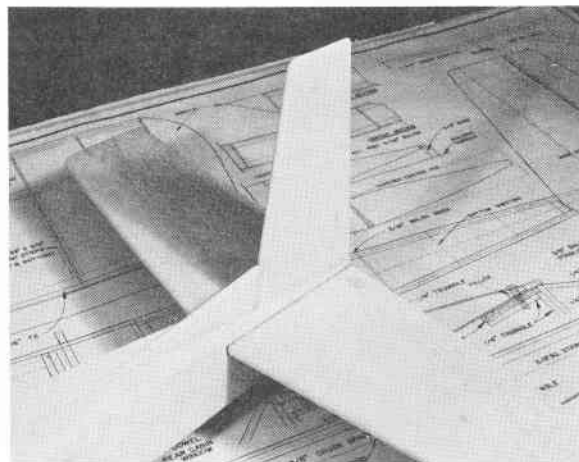

34. Glue the Stabilizer to the fuselage making sure the stabilizer tips are the same distance from the wing tips and parallel with the wing mounted in its saddle. Glue the fin to the stabilizer making sure the fin is 90° to the stabilizer. Glue the Dorsal Fin to the fin and fuselage. Remove the wing. Now finish sand the fuselage and fill any cracks, holes or dents. Microballoons and resin are good filler materials to use. You can also make fillets between the fin and stabilizer for a smoother look, however these make it more difficult to apply heat shrink covering.

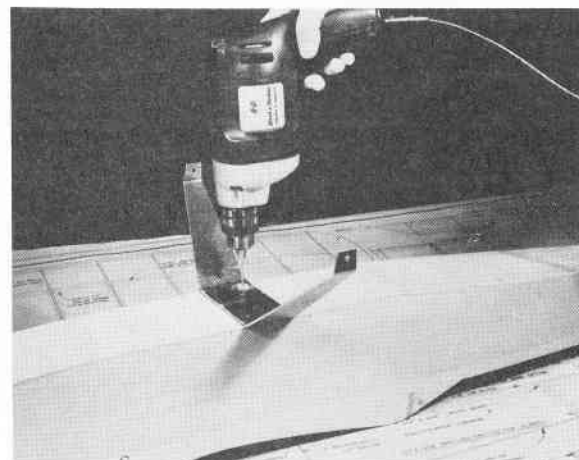

35. Mark and drill holes through the dural landing gear for mounting screws. Drill pilot holes through bottom of fuselage through landing gear plate using the landing gear as a guide for placement. Trial fit gear and remove until model is finished.

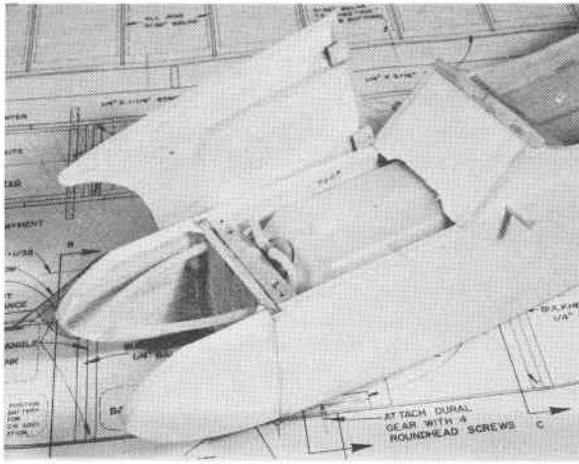

36. Remove the hatch. Assemble and install the fuel tank into the tank compartment. Thread the fuel line and vent line through bulkhead A. (firewall). Support the tank with foam. Hollow out the hatch and rear hold down for fuel tank clearance. You want the tank in the position shown on the plans for correct fuel intake.

NOTE: See the last two pages of this book for drawings of the pushrod linkage and hardware used.

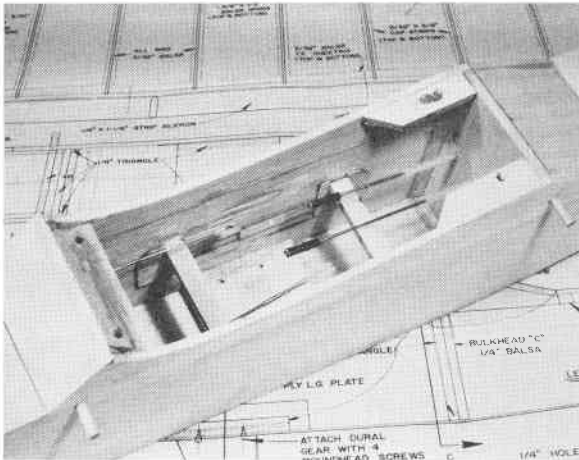

H. INSTALLING THE RADIO AND LINKAGES

1. The servo and linkage installation may be done before or after covering the model. If installed before it will have to be removed and reinstalled later, however this saves dents in the covered and finished model! Install the Servo Rails (Hardwood) and die cut servo rail braces in the fuselage. Placement of rails varies so refer to your radio manual for set up of servos. They may be mounted in a tray or on the rails themselves. Install the inner pushrod tubes and clevises.

2. Most engines have right hand throttle control. If this is the case on your engine, mount the servos as follows: the throttle servo on the right or front, the elevator servo in the middle and the rudder/nose wheel servo on the left. The rudder horn mounts on the left side of the rudder after the model is covered. If your engine has left hand throttle control, reverse the throttle servo position. Put the rudder horn and nosewheel steering arm on the opposite side. Temporarily attach the pushrods to the servos.

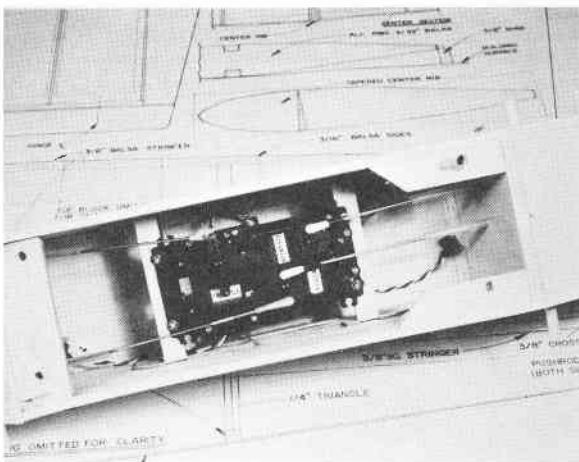

3. Cut the well (opening) in the wing for the aileron servo. If you previously cut the slots in the ribs, then all you do now is to cut through the center wing sheeting. Glue small servo rails (hardwood) (not supplied) in the well. The rail in the front is glued directly to the spar. You will have to cut away more of the ribs to glue the rail next to the spar. Glue the rear rail to the center wing sheeting. Sand the fiberglass so the glue will adhere better. The deeper you put the servo into the wing the better.

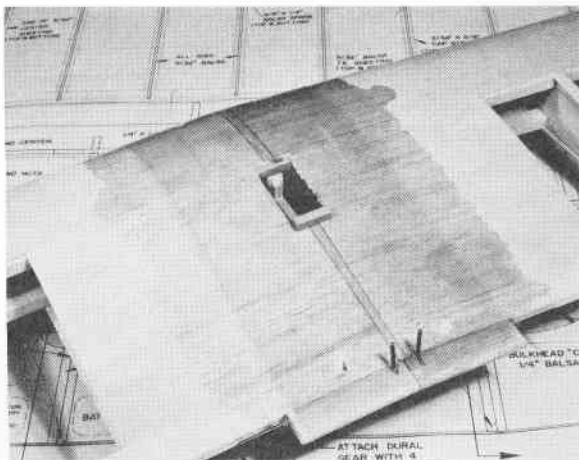

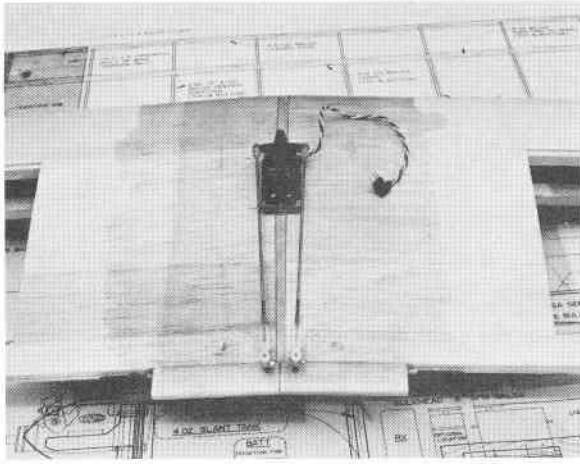

4. Drill pilot holes and screw in the servo to the servo rails. Use rubber grommets supplied with your radio between the servo and the servo rail. Temporarily install the servos and linkage to check your work. Use the wire pushrods and clevises provided for aileron linkage.

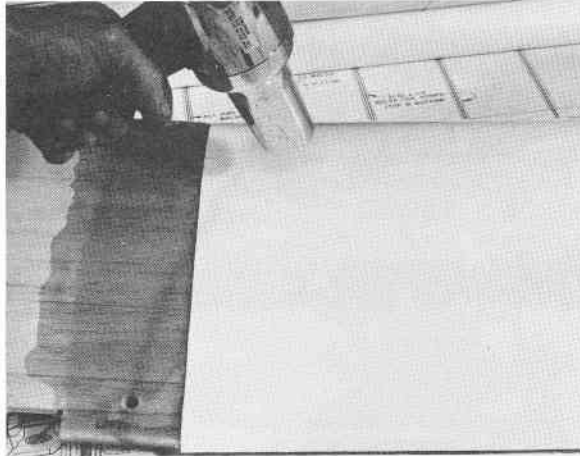

I. FINISHING THE MODEL

1. Remove the landing gear, engine, radio components and anything that would get in the way of covering or painting the model. You may cover the model with plastic heat shrink material or use paint as a finish. Follow manufacturer's recommendations in either case.

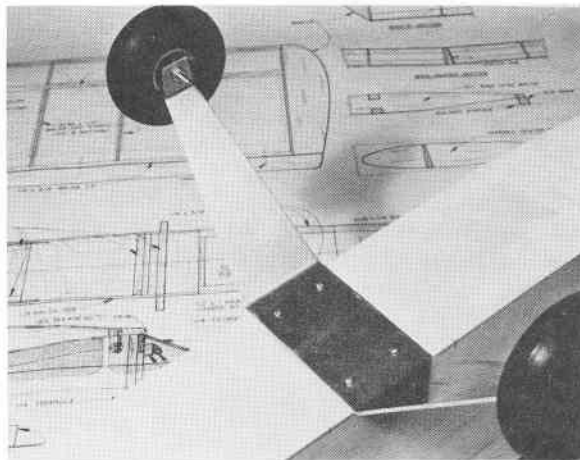

2. Attach main landing gear with four screws at the positions shown on the plans. Install the main wheels and nosewheel. Use 8-32 x 1-1/2" bolts and nuts for main gear axles. See plan. Attach nosewheel with wheel collars (not provided), one inside the wheel and one outside the wheel.

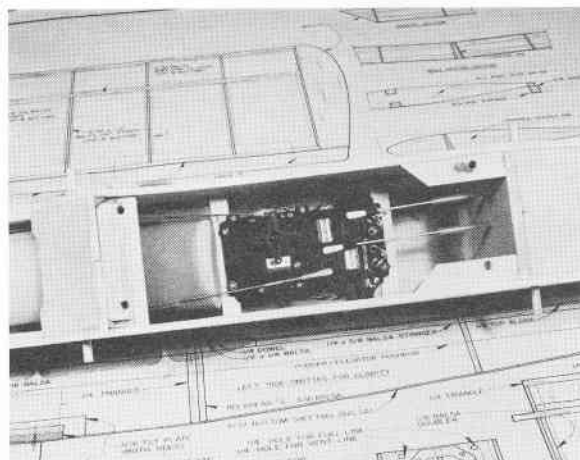

3. Reinstall the radio components: servos, receiver and battery. Refer to the radio manufacturer's instructions for installation of these components. Wrap the battery and receiver in plastic bags and cushion with foam. Install inner pushrods and attach to servos.

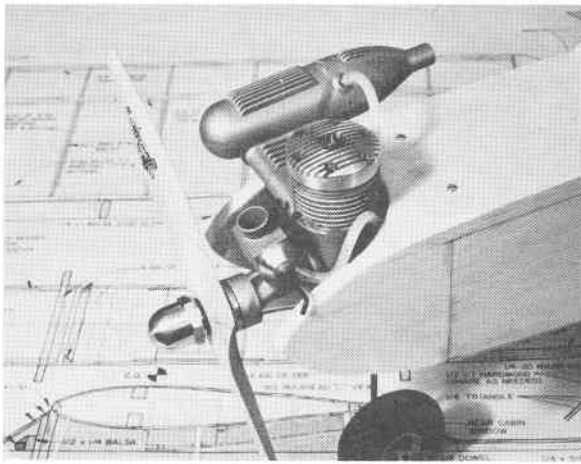

4. Reinstall the motor mount assembly and the engine/muffler assembly. Add the propeller and spinner. Refer to engine manufacturer's recommendations for propeller size. Attach throttle linkage to engine. Attach steering linkage. Use 36" wire provided for throttle and steering linkage. Add wheels.

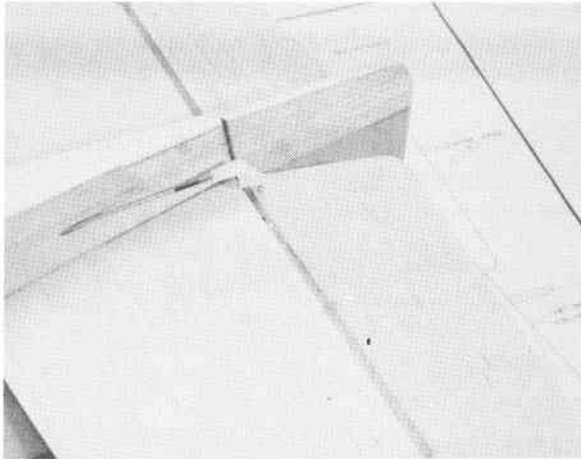

5. Glue the control surfaces to the model at the hinges with epoxy. Hinge the ailerons to the wing and hinge the rudder to the fin. Cut the bottom hinge slot for the rudder in the fuselage. Glue the elevator joiner to the elevators. Hinge the elevators to the stabilizer. Attach the nylon control horn to the elevator with two 2-56 screws. Attach the inner pushrod to the control horn with a clevis and metal threaded rod.

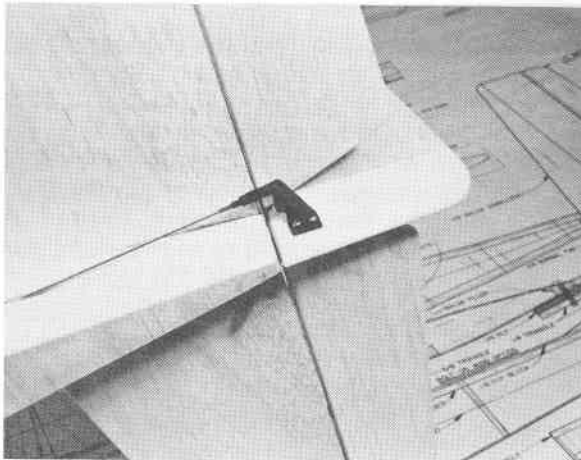

6. Attach the rudder horn to the bottom rudder left side (reverse if the engine has left throttle control) using the screws provided. Attach inner pushrod to horn with a clevis and metal threaded rod.

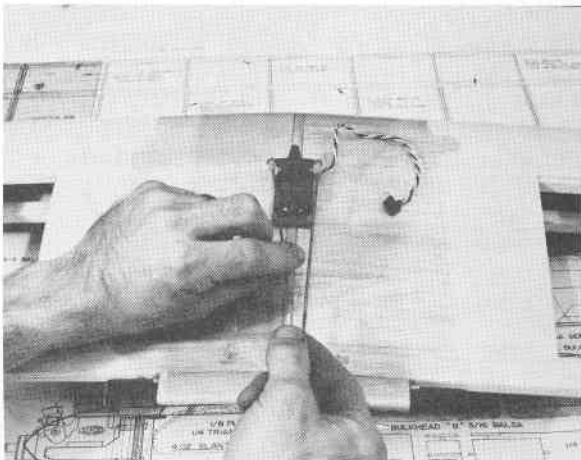

7. Adjust the throw of the ailerons. The servo should be in the neutral position. The throw should be $\frac{3}{16}$ " up and $\frac{3}{16}$ " down for training purposes. Adjust by turning the clevis on the threaded rod at control arms. Later you can increase the throw to $\frac{3}{8}$ " up and down for sport flying.

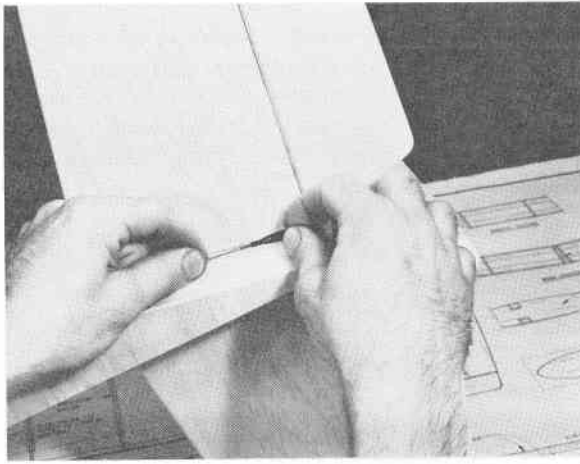

8. Adjust the elevator and rudder throw. With the servos in neutral positions adjust as follows: Elevator = $\frac{3}{8}$ " up and down, Rudder = $\frac{1}{2}$ " left and right. Adjust at the clevises. Later you can increase the elevator to $\frac{1}{2}$ " up and down and the rudder to $\frac{3}{4}$ " left and right for sport flying. The nosewheel can be adjusted to $\frac{3}{8}$ " left and right.

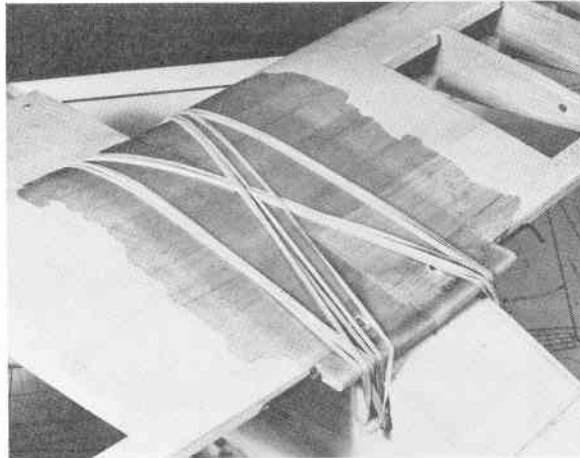

9. Use minimum of eight rubber bands when you attach the wing to the dowels: 2 on each side and 2 diagonally each way.

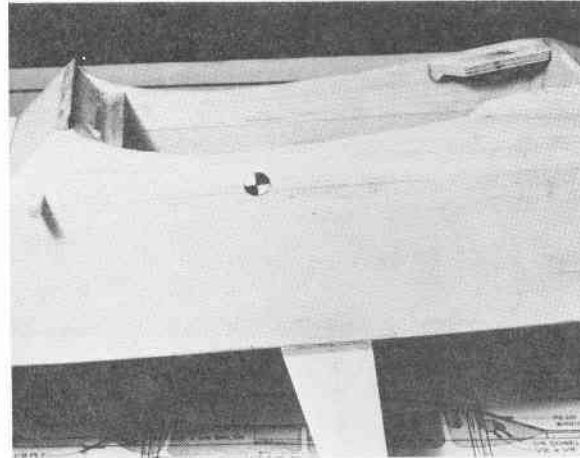

10. Check the center of gravity of the model near the fuselage at the point shown on the plans by balancing the model under the wing on your fingertips. (This position is just behind the wing spars.) Move the battery and or receiver until model balances at this point. There should be no fuel in the tank when you check the center of gravity. If the battery cannot be moved adequately to result in the C.G. shown, add strip weight as far forward or rearward as possible until the correct position is achieved. *Do not attempt to fly the model until this step is completed accurately!*



11. If this is your first model, get an experienced flyer to help you with your first flights. Usually one can be found through your local hobby shop. He/she can help you range check your radio system and help you learn the basics of R/C flying including the safety precautions and etiquette involved. Good Luck and thanks for building a Great Planes' model!

PUSHROD LINKAGE

THROTTLE

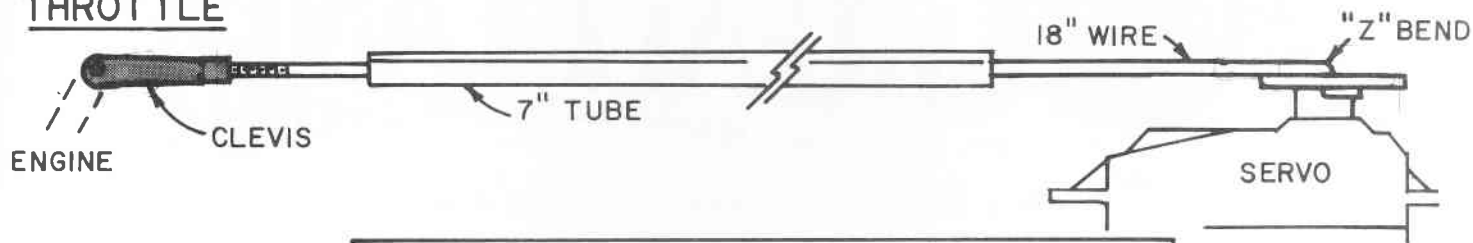

NOTE-CUT 36" WIRE IN HALF. USE ONE PIECE FOR THROTTLE PUSHROD AND THE OTHER PIECE FOR STEERING PUSHROD. TRIM WIRE TO FIT.

NOSE GEAR STEERING

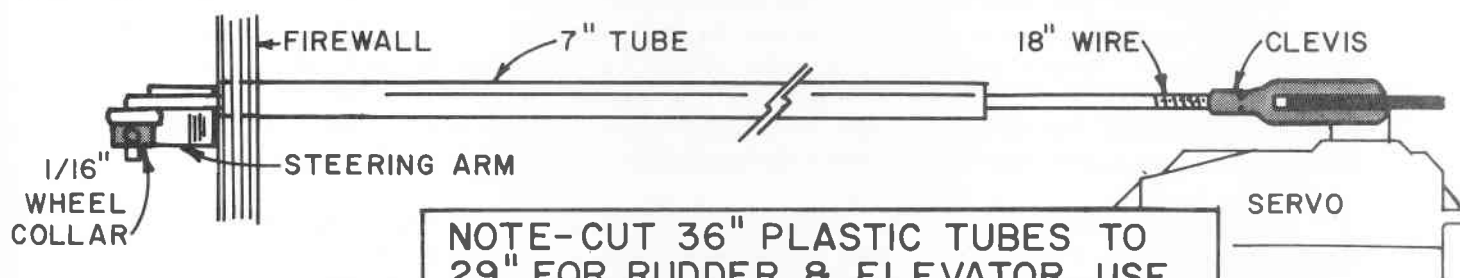

NOTE-CUT 36" PLASTIC TUBES TO 29" FOR RUDDER & ELEVATOR. USE 7" PIECES LEFT OVER FOR THROTTLE AND STEERING. TRIM TO FIT.

RUDDER

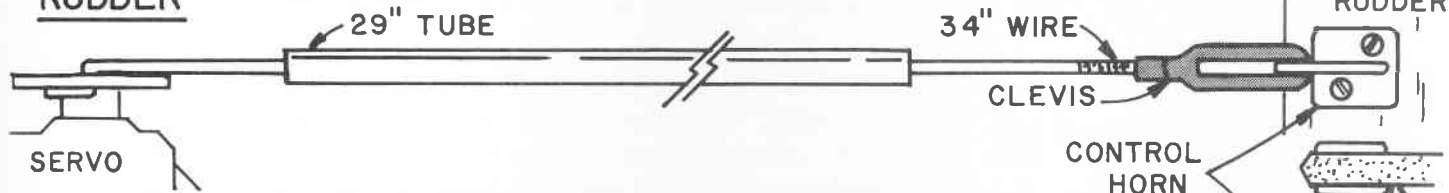

ELEVATOR

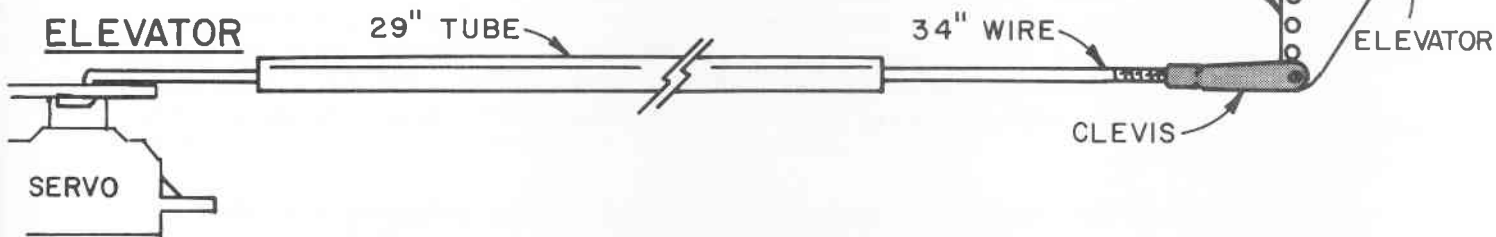

AILERONS

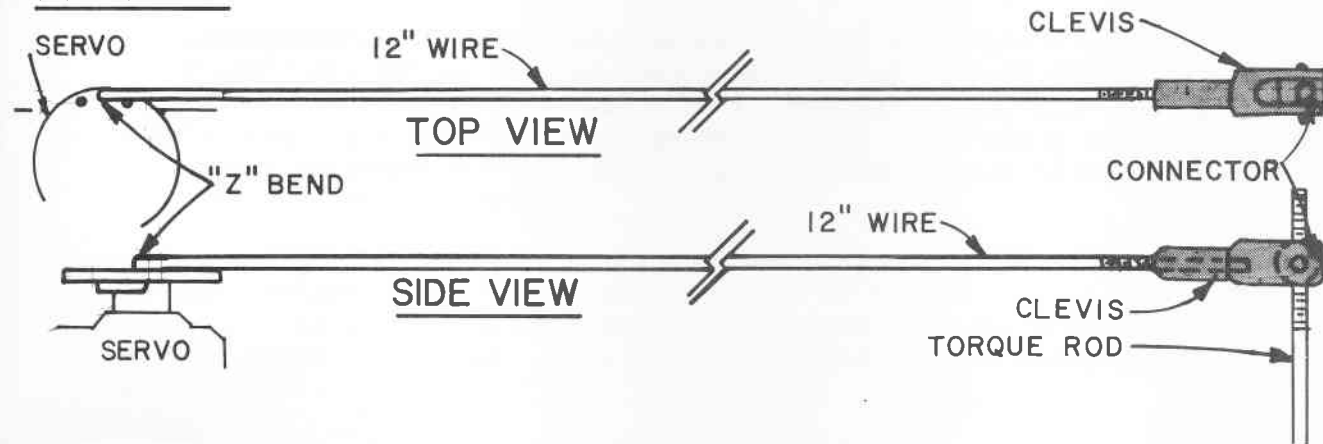



P.O. BOX 721 URBANA, ILLINOIS 61801

TRAINER SERIES 4-CYCLE CONVERSION INSTRUCTIONS

Four cycle engines are becoming more popular and available every day. Our roomy trainers are a natural place to try one out. These engines offer many benefits: their quiet, realistic sound is pleasing to modelers and non-modelers alike. High torque allows the use of high pitch or large diameter propellers for a new style of flight characteristics. They are also very fuel efficient for economical operation.

On the other side of the coin, 4-cycles are larger and heavier than equivalent power 2-cycles. That means some special care must be taken to avoid a nose heavy airplane, such as moving the firewall and radio farther back than normal. We'll help you with that task with these instructions.

Since these instructions are written for all three trainers, the Twenty, the Forty and the Sixty, read the appropriate section for your particular model.

CHOOSING YOUR ENGINE

It's difficult to say exactly what the optimum engine size is for your Trainer. The old rule of thumb was to choose a 4-cycle engine with 1-1/2 times the 2-cycle displacement for equivalent horsepower. But recent advancements by engine manufacturers have brought the power of 4-cycles way up, and the weight of the engines down. One good example is the Enya .46 Four Cycle. This engine weighs just a fraction more than most 2-cycle .40s and it produces comparable power and thrust.

TRAINER TWENTY: For this airplane a Saito .30 will give comparable power to a 2-cycle .20 but weighs more and is larger than a 2-cycle. See page 7 for a drawing of the Saito .30 in the Trainer Twenty.

TRAINER FORTY: For this plane you can choose between a .40 and a .60 size four cycle. A .40 will give docile flight performance. A .60 provides plenty of thrust, but with a significant increase in weight and size. The .60 will fit but it is going to be tight. See page 8 for a full size drawing of the Saito .45 mounted in a Trainer Forty. The OS FS-61 is shown on page 9.

TRAINER SIXTY: This model is well suited for the .60 to .90 size 4 cycles. Some of the new .60 size engines are putting out high thrust that will make a light Trainer Sixty perform nicely. Enya's .90 4-cycle, the OS FS-61, or a Saito .65 are all ideal choices for training or general sport flying with this aircraft. A .90 4-cycle will turn your Trainer Sixty into a very aerobatic trainer. Pages 10 and 11 show the OS FS-61 and the Enya .90 mounted in the Trainer Sixty.

CHOOSING A MOUNT

Low weight and rigidity are important in 4-cycle mounting. Hayes and Tatone both make good mounts for 4-cycle use.

The Hayes mounts will fit the .40s, .45s and .60s. The AL-40 is good for the Saito .30, the Enya.46 and the Saito .45. The AL-60 will fit the Enya .60 and the OS FS-61. Currently Hayes does not make a mount for .90 use.

Both brands are lightweight. To improve stability, we recommend installing a front bulkhead. This essentially gives a beam mount system that is extremely rigid but makes removal of the mount a little more cumbersome.

BUILDING PROCEDURE

Use the instruction book and build your model using these instructions to replace the steps referring to 2-cycle installation. Read these steps and note where changes to the main instruction occur before you build.

BUILDING THE FUSELAGE

Step 2 (page 10 in the instruction book)

Prepare Bulkhead A, the Firewall. (The Firewall is the same as the Landing Gear Plate.) Mark the top of the Firewall. Mark the centerline of the engine on the Firewall and center your 4-cycle mount in position. The thrust line of the engine should be in the same position as shown on the plan. Drill holes and install blind nuts. We suggest substituting 6-32 bolts and blind nuts to mount the motor mount to the firewall. Temporarily install the mount and trim the mount bolts that extend into the tank compartment if necessary. Drill a hole for the throttle pushrod to the carburetor making sure the throttle pushrod does not interfere with the fuel tank.

Next bolt the engine to its mount. If you use a Hayes mount, position the engine as far back as possible leaving sufficient room for engine and/or carburetor clearance. Make sure you don't put in any right or left thrust.

Then measure the distance from the back of the mount to the prop/thrust washer. To do this, place the engine and mount on a flat surface and put a straight edge across the thrust washer. Measure back from this straight edge to the back of the mount. This distance is "B". You are measuring this distance so you can determine how far back to move the Firewall so the engine will fit into the nose of the model.

Now lay your 4-cycle engine/mount assembly on the plan over the side view of the fuselage. Line up the thrust washer of your 4-cycle with the thrust washer on the 2-cycle on the plan. Mark on the plan where the rear of the 4-cycle mount is located. This is the new position for the front of the Firewall, (Bulkhead A).

Another way to get this position is to measure the distance from the thrust washer to the rear of the mount on the plan (Distance A). Measure your 4-cycle and mount the same way (distance B). Then subtract A from B to get the distance you move the Firewall.

Either of the above methods will work. Just remember to allow enough room for the thrust washer to extend beyond the nose.

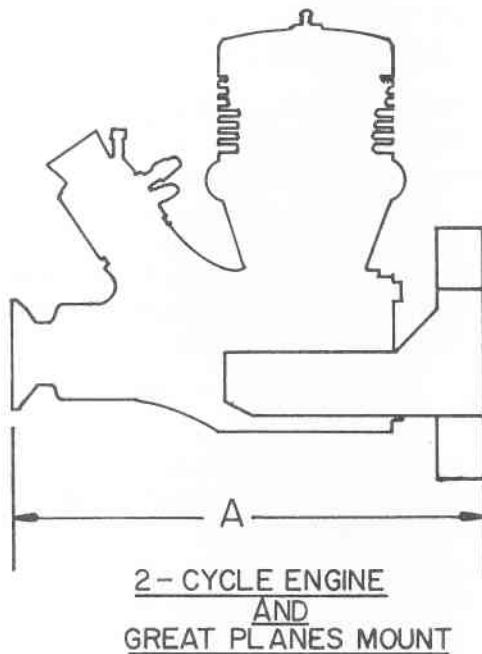

Figure 1

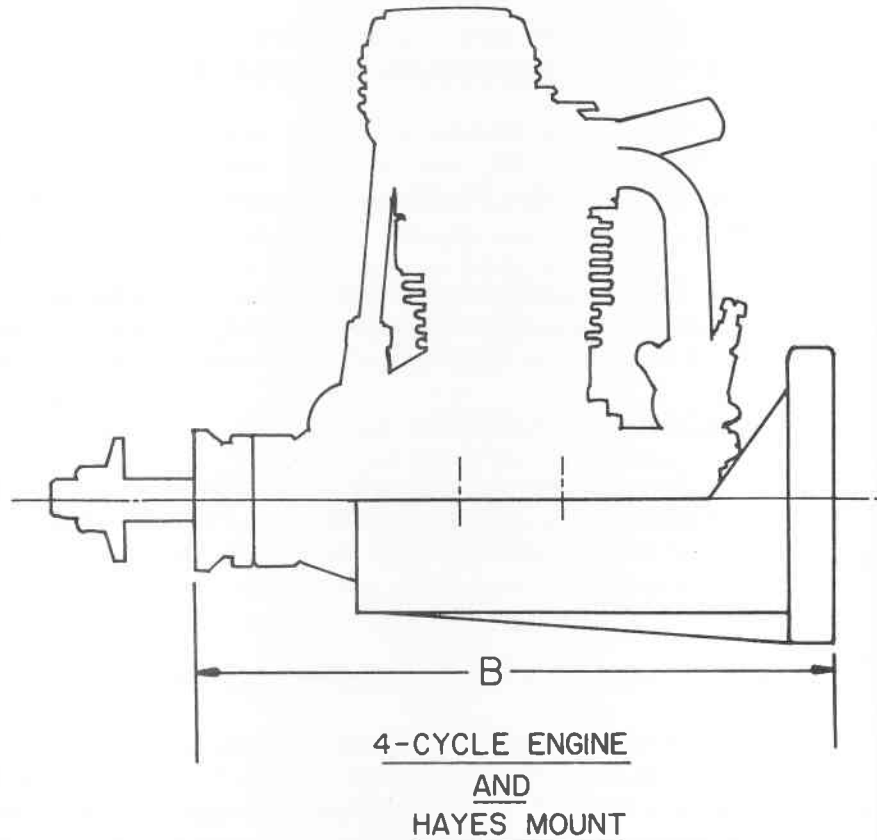

Figure 2

Step 3 (page 10)

Drill a hole in your new mount for the nosegear. If necessary cut away the bottom part of the Firewall for nosegear coil clearance. Trial fit the nosegear assembly to the Firewall. When using a Tatone mount, you will find it necessary to mount the nosegear in separate nosegear bearing blocks, such as Dubro #156. Mount the nosegear on the back side of the firewall, inside the tank compartment.

Step 4 (page 11)

Mark the new position of the Firewall on the inside of both fuselage sides. Make sure your line is perfectly parallel to the front of the fuselage sides. Glue the Firewall (Bulkhead A) 90 degrees to the right fuse side in its new position.

Step 5 (page 11)

Cut the balsa doublers provided at the front to match the distance you moved Bulkhead A. Glue the doublers in place on both fuse sides. The rear of the doublers should end up in the same place as the 2-cycle installation. Now glue in balsa fillers the same thickness as the doublers in front of Bulkhead A to the front of the fuse side. See Figures 3 and 4. These fillers should be vertical-grained. Sand the fillers flush with the fuse sides. Add 1/4" balsa filler below Bulkhead A later when you remove the fuselage from the building board.

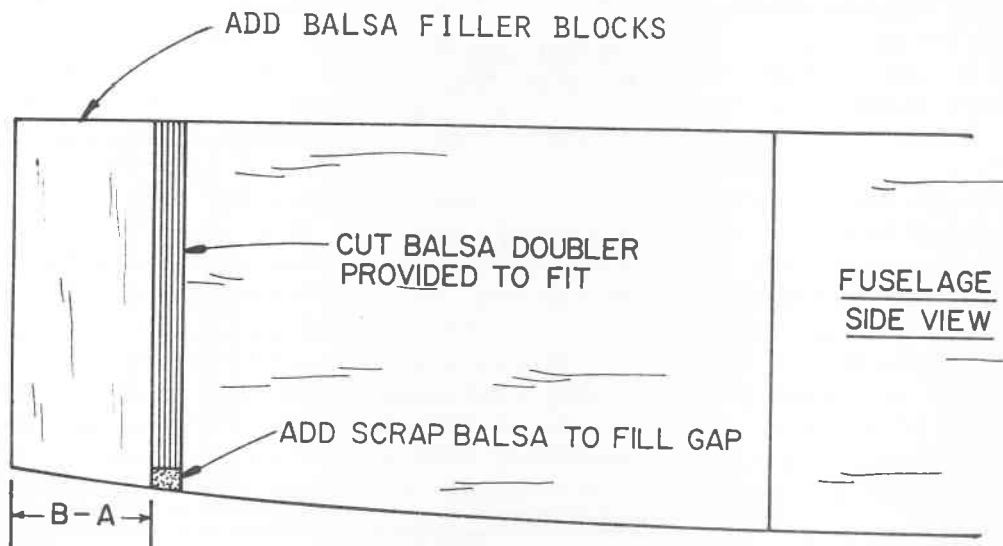

FIGURE 3

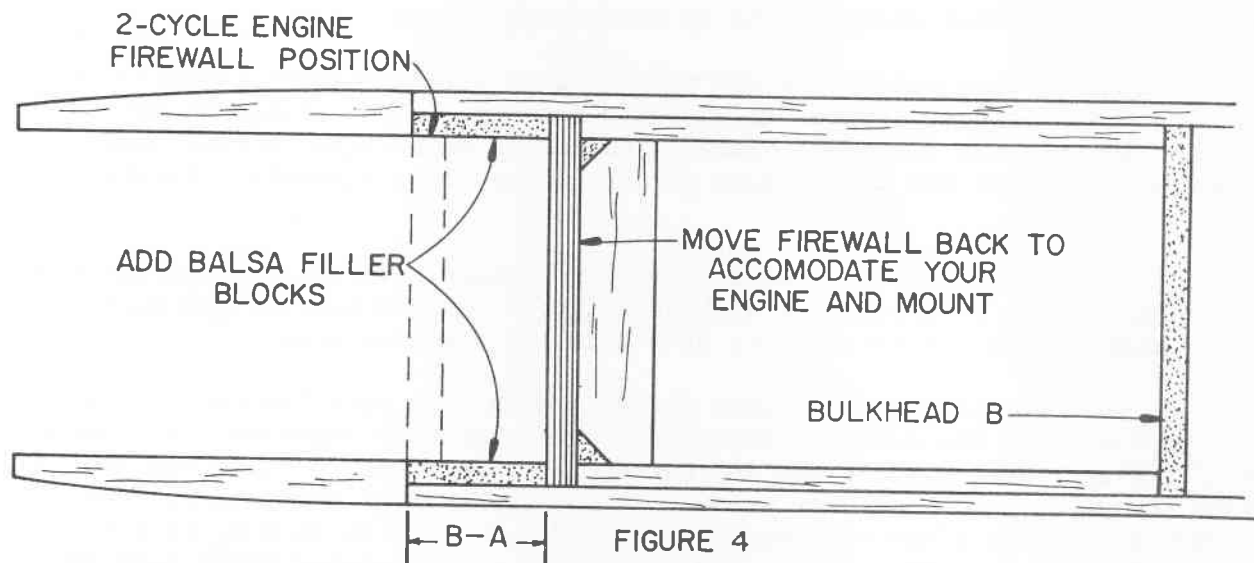
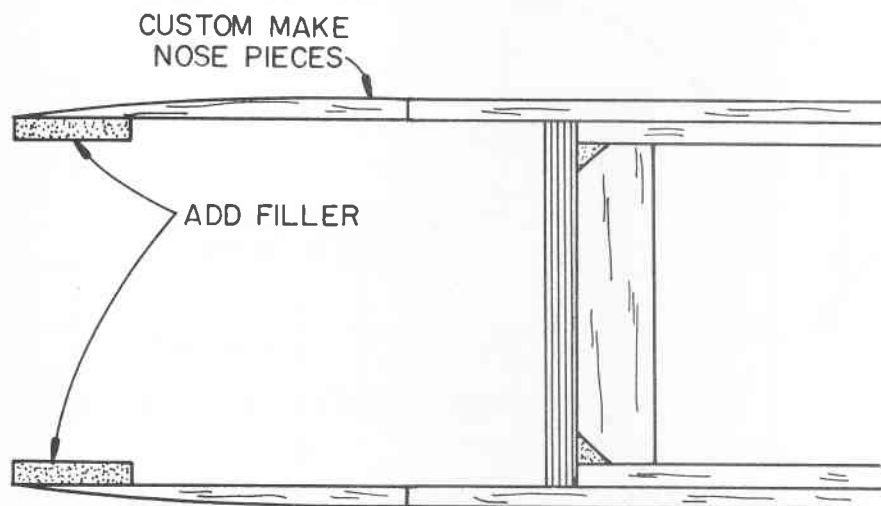

FIGURE 4

Step 28 (page 17)

Check for adequate width clearance of your engine. Most engines should fit just fine. But if your 4-cycle and mount is over 2-1/2" wide for the Trainer Twenty, 2-5/8" wide for the Trainer Forty or 3" wide for the Trainer Sixty, you'll need to cut away part of the balsa nose blocks and filler pieces in the engine mount area. Instead you can custom make balsa nose side block pieces as shown in Figure 5. Now follow step 28 in the instruction book about gluing these side pieces to the fuselage.

Next add a front bulkhead to the engine mount as shown on the drawings on pages 7 through 11. Make this bulkhead from 1/8" plywood. Once the front bulkhead is epoxied in, drill the front of this bulkhead and the mount for 4-40 bolts. Tap the mount and install the 4-40 bolts.



GENERAL INFORMATION

FIGURE 5

Center of Gravity: A nose heavy airplane can be a problem! Make sure you check the CG location during construction with the radio components installed. You may need to put the radio as far back in the compartment as possible. This will avoid having to carry tail weight.

Props: Always start with the manufacturer's instructions (especially for break in) for prop selection. Read their instructions carefully because 4-cycles use entirely different diameter and pitch propellers because they operate at a lower RPM and produce greater torque than equivalent displacement 2-cycles.

You may find that after operating your Trainer with the recommended props that you'll want to experiment with other props. It is amazing how much you can change flight characteristics of a model by changing props.

If you are looking for higher flight speeds from your Trainer than you are getting from the average recommended prop, consider reducing the diameter and/or blade area slightly and increasing the prop pitch to bring the RPM back to the normal range. For example, with our Enya .46 equipped Trainer Forty, the instructions recommend 13 x 5, 12 x 6, 11 x 7, 11 x 6, 10 x 6, 10 x 7 or 10 x 8 props. We started with an 11 x 6 propeller which gave us fair performance. For faster speed we found that a 10-1/2 x 7-1/2 propeller added approximately 10 mph to the straight and level flight which helped make vertical maneuvers crisper due to a faster entry speed. However the idle was faster and made the plane land a little faster. The prop we used

was a prop designed for .60 size pattern engines, a Max Daily (Radio South) propeller. A similar prop is available from DW Products. Their addresses are:

Radio South
180 E. Burgess
Pensacola, FL 32503

DW Products
5634 Crystal Ct.
Santa Rosa, CA 95404

Fuel Tank: For simplicity, we recommend a 2 line tank for your Trainer. If you can't easily reach the fuel line for fueling purposes, you might consider using one of the new Dubro fueling valves. This will save extra plumbing that could leak or cause problems. Most 4 cycles have a small enough venturi that muffler pressure is unnecessary. Don't forget the crankcase drain line. A lot of excess fuel comes out of the pressure fitting. Make sure this drainage exits your fuselage. Treat it as though it were a separate exhaust.

Flying: Other than the obvious sound difference, you'll notice one other big difference from your first take off with a four cycle equipped Trainer: You'll need to add more right rudder than normal to counter the increased torque on acceleration during takeoff. Also, you may be surprised how big an effect the larger propeller may have on abrupt change maneuvers such as a square loop. Because there is more mass to the propeller, it has a larger gyroscopic force. When you change directions in maneuvers like a square loop, you may find that the plane changes heading. This may be the result of gyroscopic precession and/or P-factor. These factors become more prevalent with larger diameter 4 cycle props and with slower speeds generally encountered with these engines.

Also don't forget to have a slight amount of toe-in with your main wheels. Toe-out and lots of torque can cause problems with ground handling. Use some toe-in, add some rudder and your takeoffs will be in a straight line.

GOOD LUCK AND GREAT FLYING!

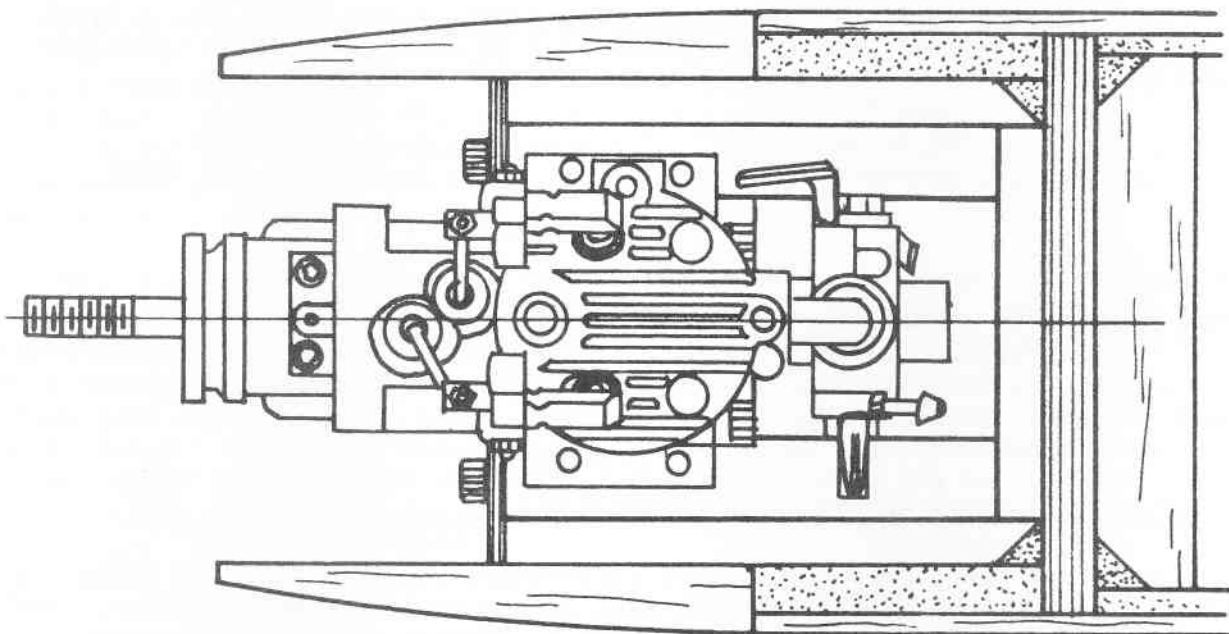

TRAINER TWENTY

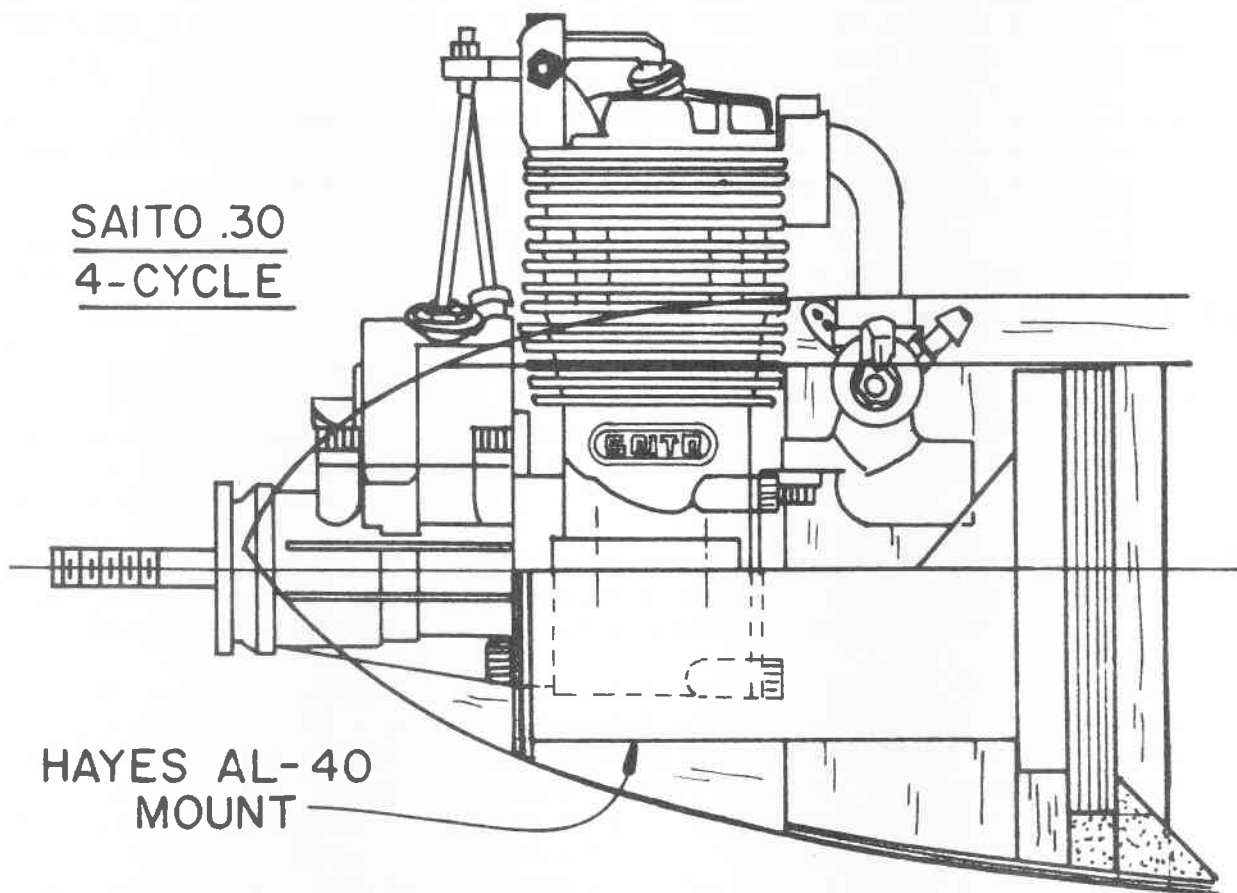

SAITO .30
4-CYCLE

HAYES AL-40
MOUNT

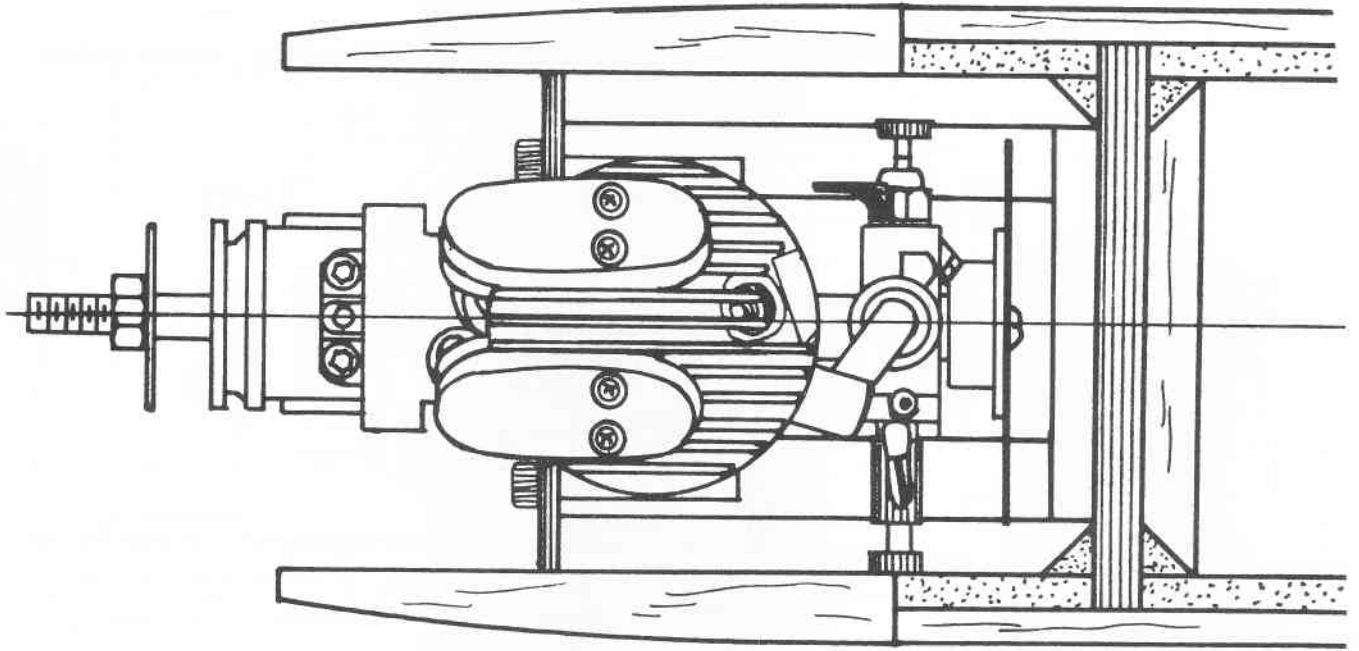

TRAINER FORTY

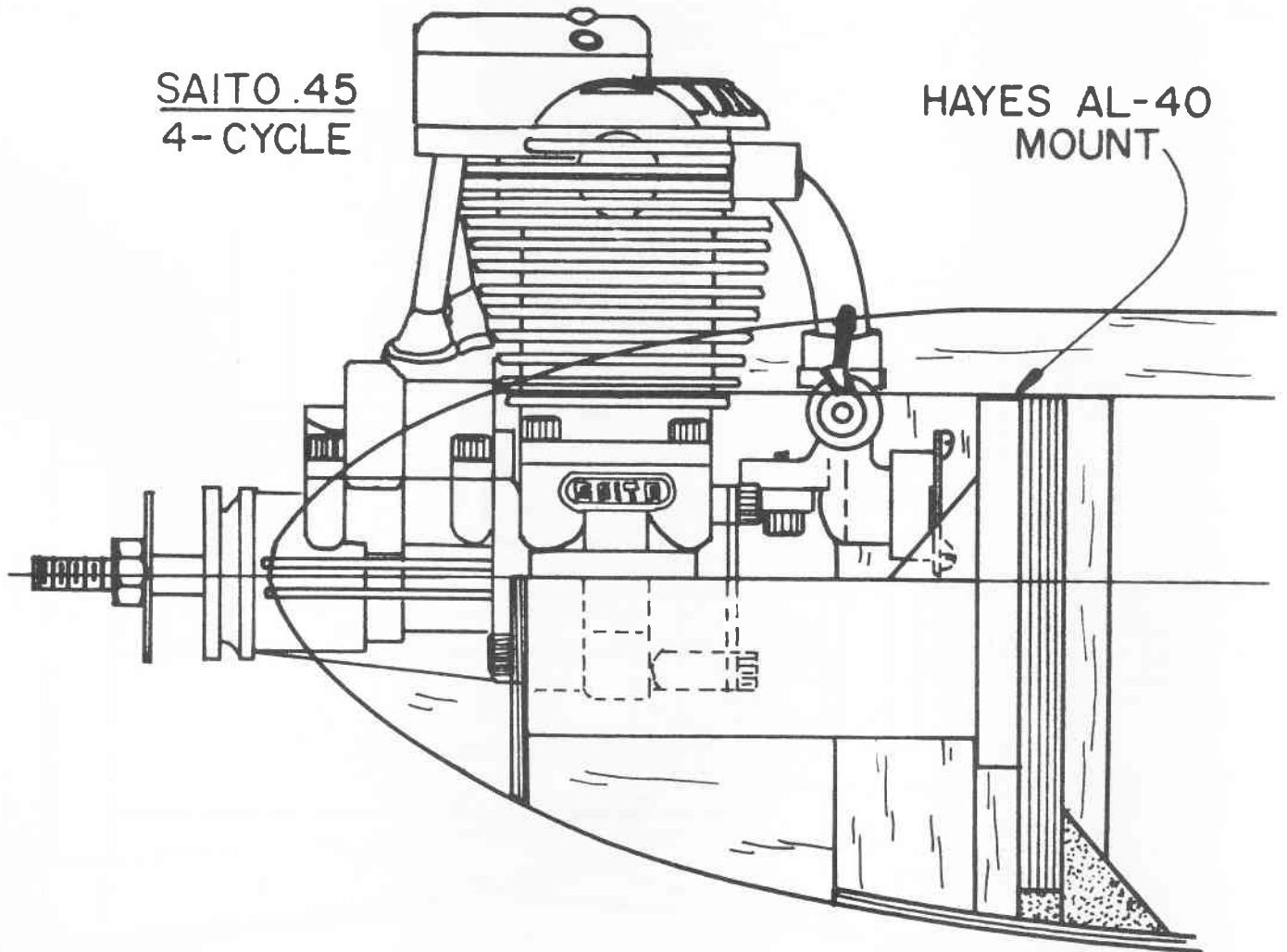

SAITO .45
4-CYCLE

HAYES AL-40
MOUNT

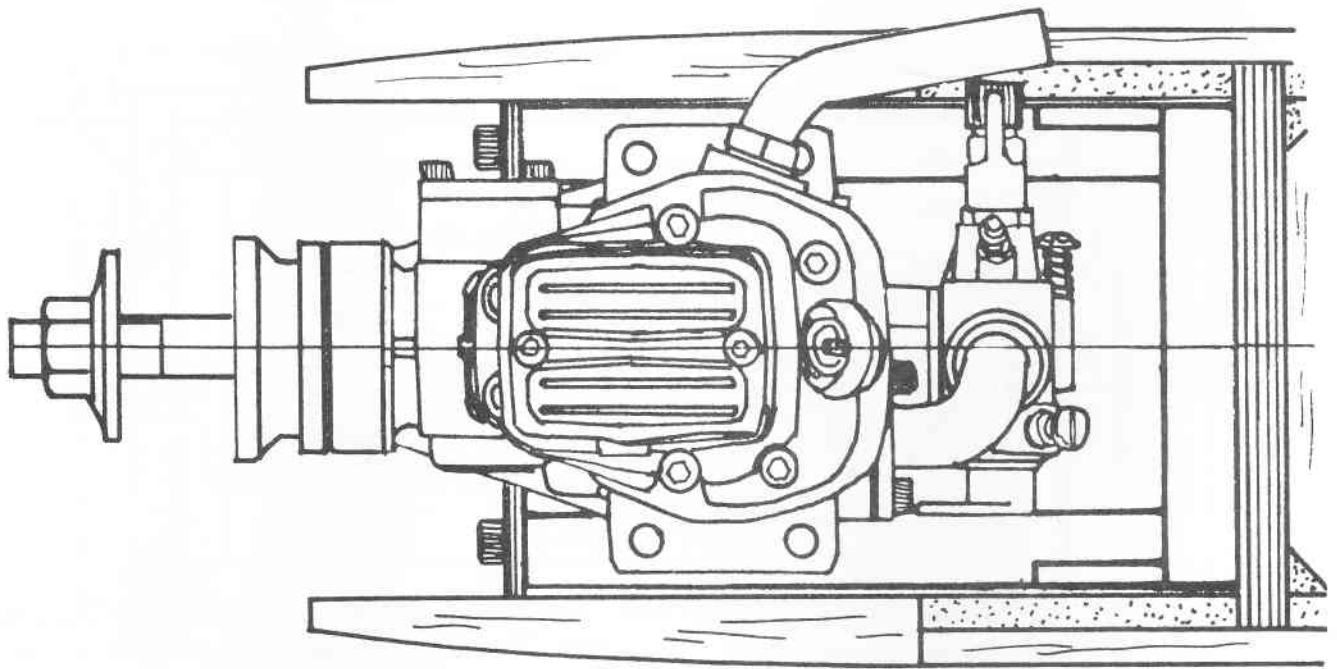

TRAINER FORTY

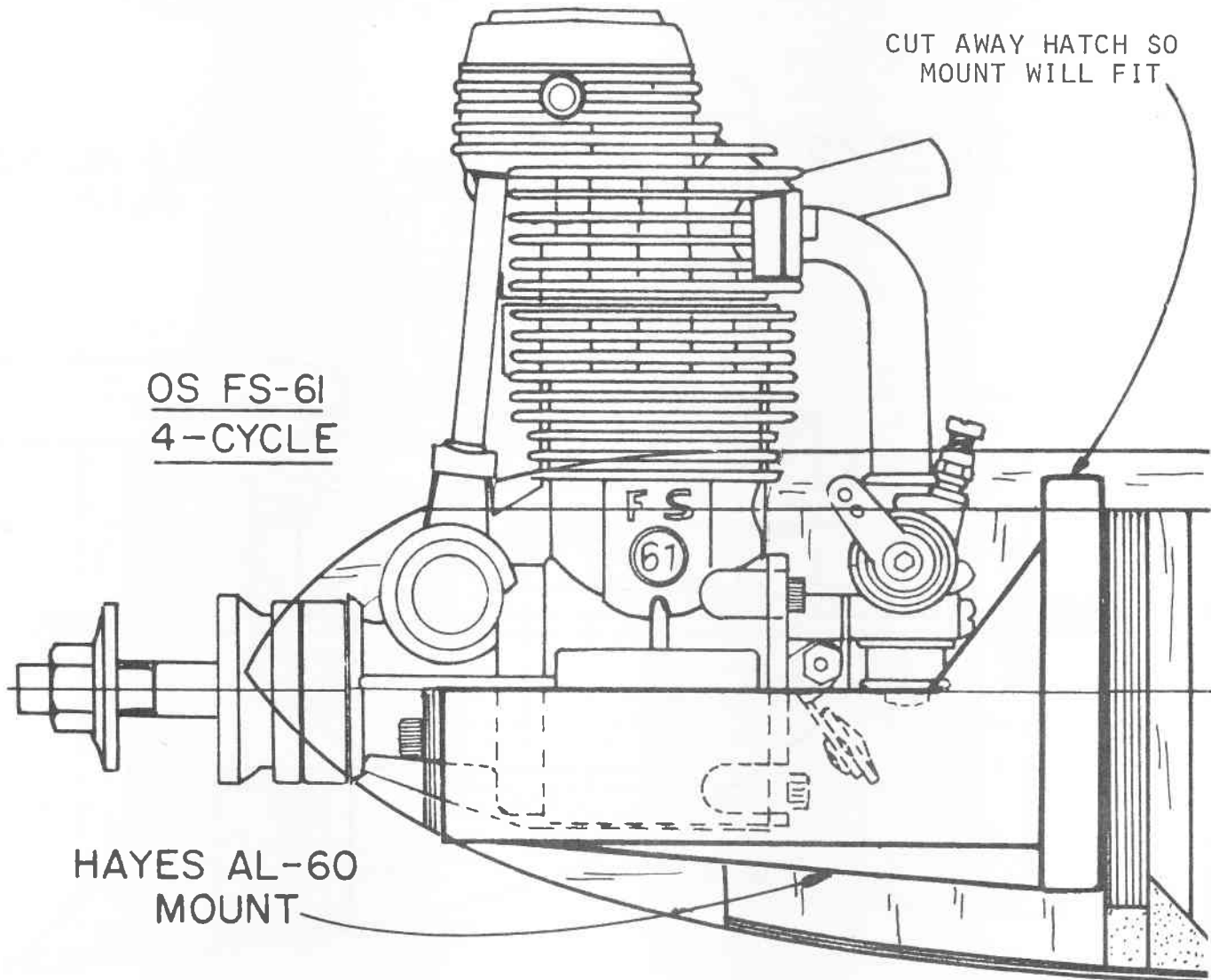

CUT AWAY HATCH SO
MOUNT WILL FIT

OS FS-61
4-CYCLE

HAYES AL-60
MOUNT

TR4C-10

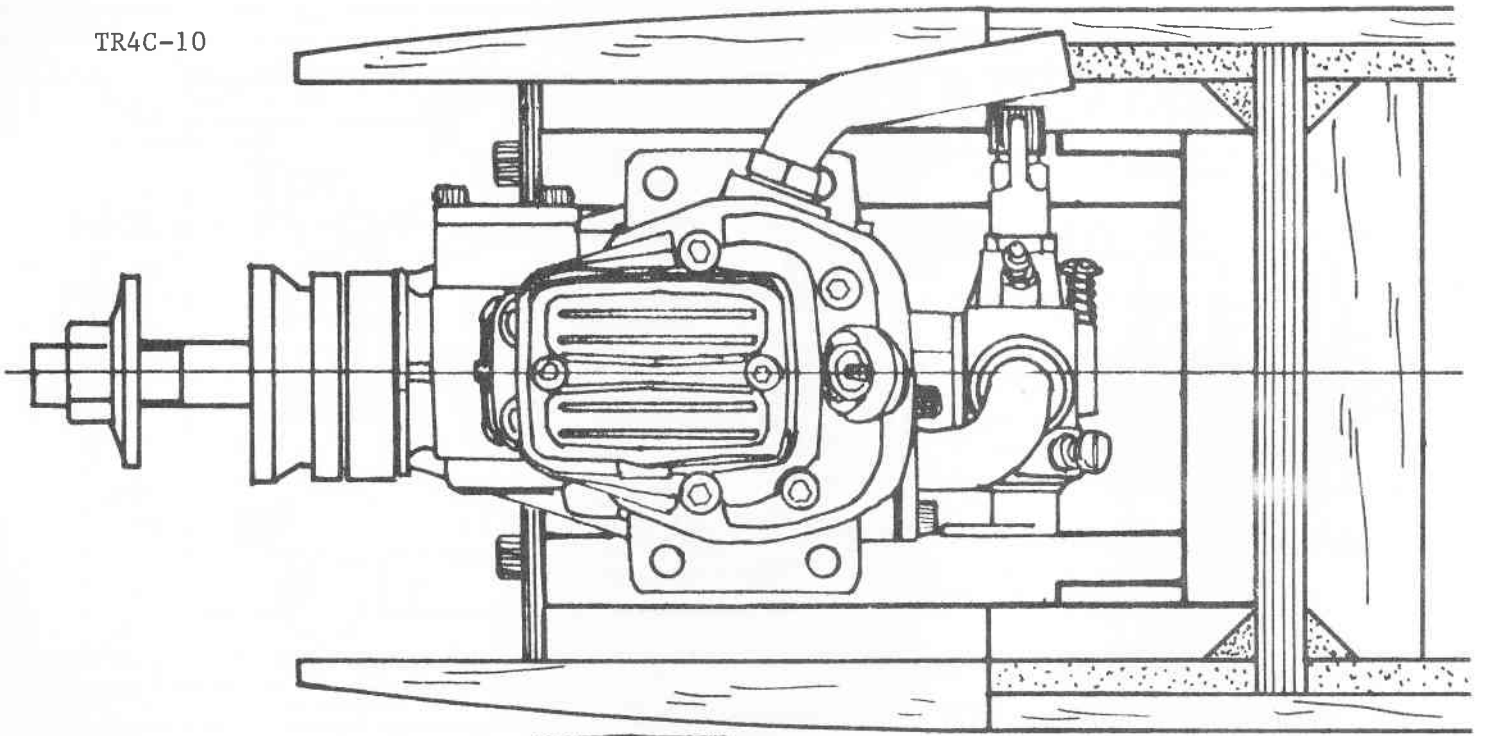

TRAINER SIXTY

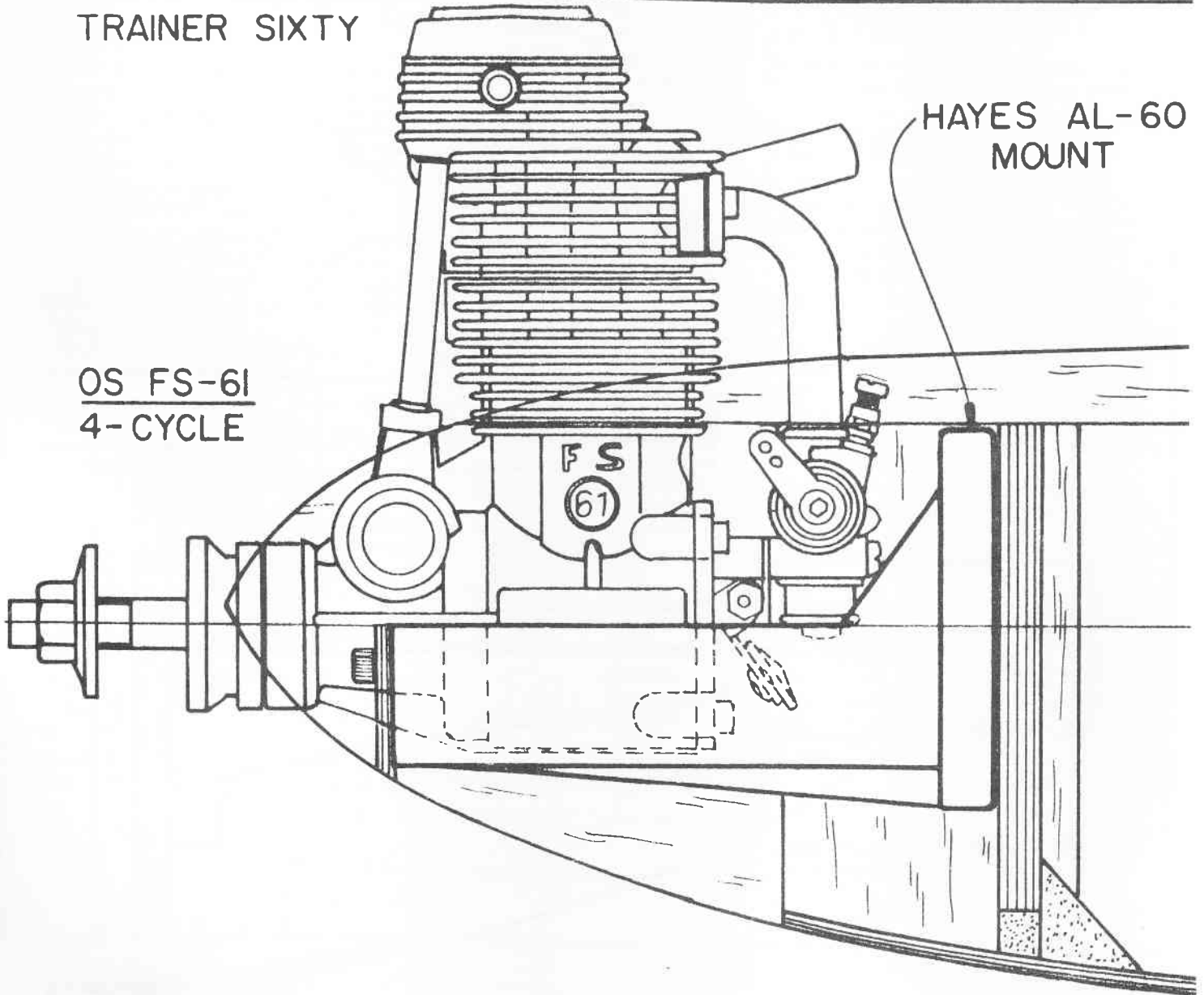

HAYES AL-60
MOUNT

OS FS-61
4-CYCLE

TR4C-11

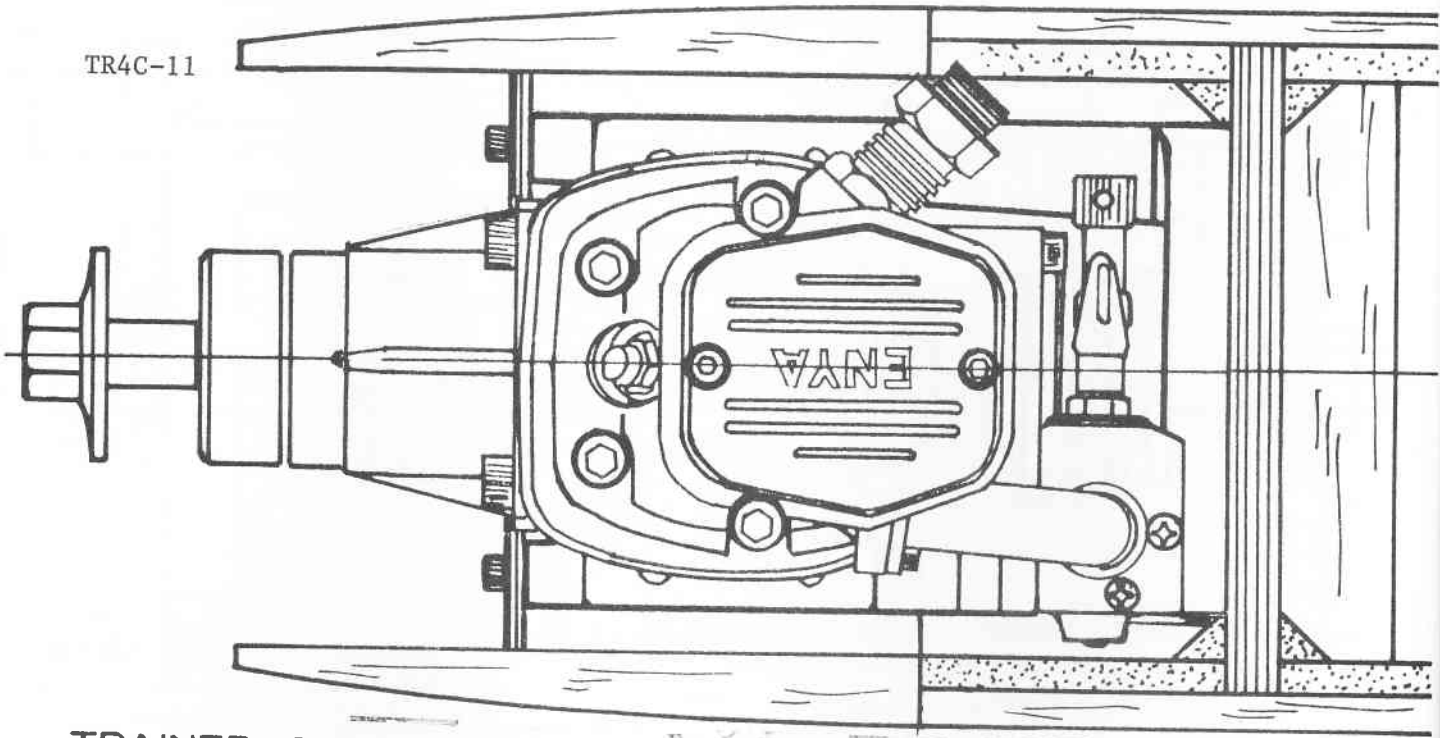

TRAINER SIXTY

ENYA .90
4-CYCLE

TATONE
MOUNT

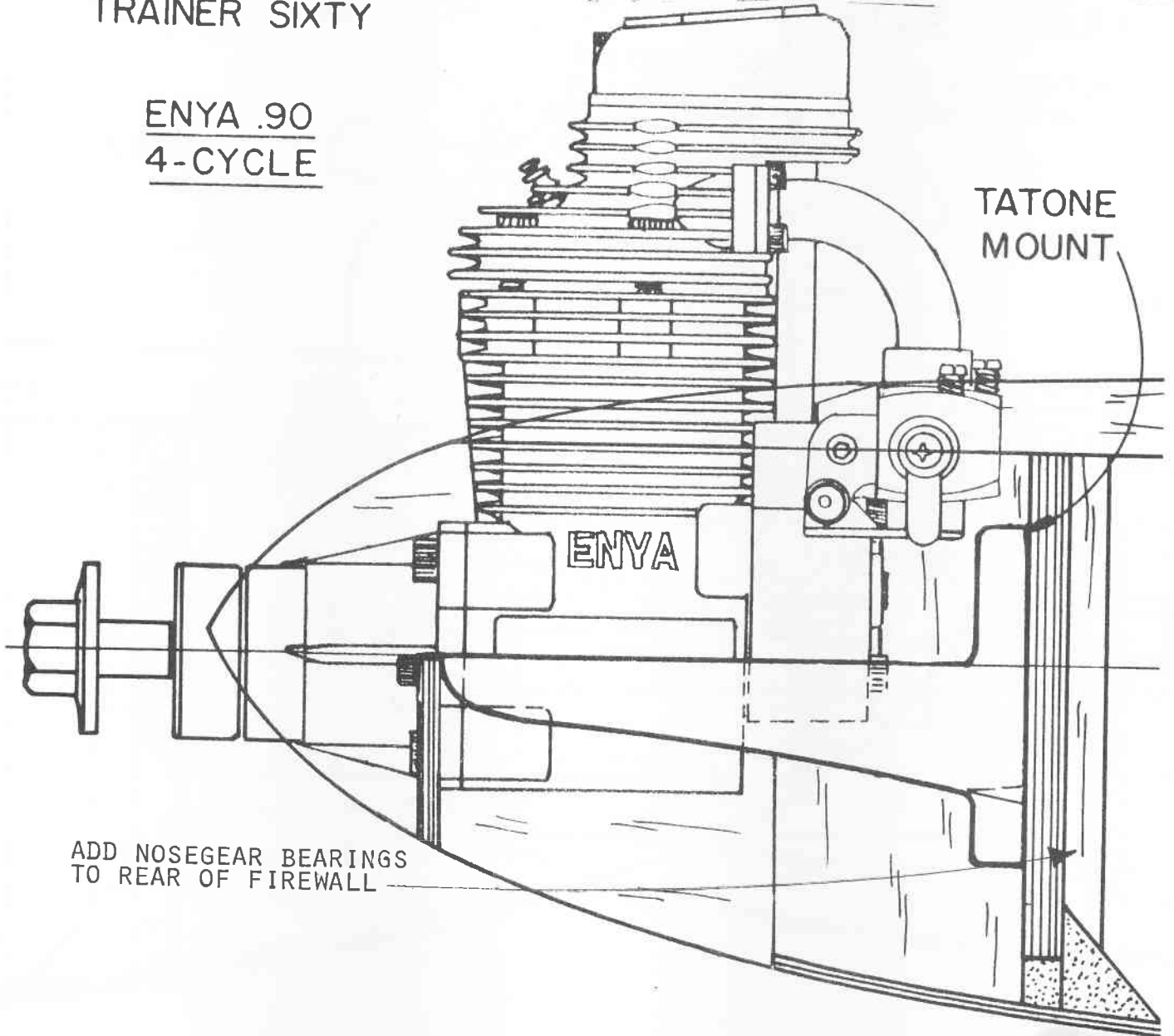

ADD NOSEGEAR BEARINGS
TO REAR OF FIREWALL

TRAINER TWENTY PARTS LIST

PART NUMBER	QTY	DESCRIPTION	PART NUMBER	QTY	DESCRIPTION
BAL009	5	Balsa 3/32 X 1/4 X 36 Wing Cap Strips	TR20A03 1 PARTS BAG-FUSELAGE PARTS		
BAL015	8	Balsa 3/32 x 3 x 7 Center Section Sht	DOWEL001	2	Dowel 1/4 Diameter x 4-13/16 HD
BAL019	2	Balsa 1/4 Triangle Brace Stock	HRDWD017	1	Hardwood 1/2 x 1 x 3 Wing Hold Down
BAL037	2	Balsa 3/16 Fin and Rudder	PLY3009	2	Plywood 1/4 Rear Hold Down
BAL098	3	Balsa 3/32 x 3 x 11-7/8 Bot Fuse Sheet	TR20F12	2	Plywood 1/16 Landing Gear Brace
BAL112	1	Balsa 1/4 Center Rib, 9" long	TR20F15	2	Plywood 1/8 x 1/2 x 2-3/4 Hatch HD
MM19D	1	Engine Mount	TR20M02 1 PARTS PACKAGE-LANDING GEAR		
PLTB002	2	Plastic Pushrod Tubes	L-1U	1	Dural Main Landing Gear
PLY3008	1	Plywood 1/4 x 1/2 x 11-3/4 Servo Rail	TR20L01	1	Wire 5/32 Nose Gear
PLY3010	1	Plywood Servo Spacer Set	TR246M03 1 PARTS BAG-HARDWARE		
TR20F01	2	Balsa 1/8 Fuselage Side	NUTS001	2	4-40 Blind Nuts(use with Hatch)
TR20F02	2	Balsa 1/8 Fuselage Doubler	NUTS003	4	6-32 Blind Nuts(Engine Mount)
TR20F03	2	Balsa 1/4 x 3/8 x 18 Top Block String	NUTS014	4	8-32 Hex Nut(use with Axles)
TR20F04	2	Plywood 1/4 x 3 x 2-3/8 Bulk.A/LG	NYLON03	2	Nylon Control Horn-(use on Rud/Ele)
TR20F05	1	Plywood 1/16 x 14-15/16 x 3-1/4 Bot	NYLON09	2	Nylon Hinges/12 ea(use on Wing, Rud/Ele)
TR20F06	1	Balsa 1/8 Top Block	NYLON13	4	Nylon 1/4-20 Wing Bolt
TR20F07	2	Balsa 1/8 Cabin Side	NYLON16	1	Nylon 5/32 Steering Arm
TR20F08	2	Balsa 3/16 x 3 x 4-1/8 Bulkhead B/C	NYLON17	4	Nylon Clevis(use with all linkages)
TR20F10	1	Balsa 3/16 Rear Window	NYLON20	2	Nylon Aileron Connector
TR20F11	1	Balsa 3/16 Front Window	NYLON21	2	Nylon Aileron Clevis
TR20F17	1	Balsa 3/16 x 1/4 x 18 Fuselage Brace	SCRW002	4	2-56 x 5/8 Screw (Control Horns)
TR20F18	1	Balsa 3/8 Hatch	SCRW003	2	4-40 x 1 Bolt(use with Hatch)
TR20F20	2	Balsa 3/8 Nose Block	SCRW004	4	#4 x 1/2 Screw(use with Landing Gear)
TR20P01	1	Plans	SCRW005	1	6-32 x 1/8 Screw(5/32 Wheel Collar)
TR20S01	1	Balsa 1/4 Stabilizer Front	SCRW008	4	6-32 x 1 Bolt(engine mount)
TR20S02	1	Balsa 1/4 x 1-7/8 x 19-3/8 Stab Rear	SCRW015	1	4-40 x 1/8 Screw (3/32 Wheel Collar)
TR20S03	2	Balsa 1/4 Elevators	SCRW020	1	6-32 x 1/4 Screw (5/32 Wheel Collar)
TR20W08	2	Balsa 1-1/2 Triangle x 8-1/8 Wing Tip	SCRW035	2	8-32 x 1-1/2 Sockethead Bolt(Axles)
TR20W09	1	Balsa 3/32 Wing Rib Set	WBNT002	1	Wire 3/32 Aileron Torque Rod Set
TR20W15	1	Balsa 3/8 x 9/16 x 25-1/8 Wing Shim	WBNT101	1	Wire 1/8 Elevator Joiner
TR246P03	1	Instruction Book	WHCL004	1	3/32 Wheel Collar (Steering Arm)
WIRES10	1	Wire-36" Threaded Pushrod	WHCL005	2	5/32 Wheel Collar(use with Nosegear)
WIRES16	2	Wire-12" Threaded Pushrod	TR20W01 1 PARTS PACKAGE-WING PARTS		
WIRES17	2	Wire-34" Threaded Pushrod	TR20W02	2	Balsa 3/8 x 3/8 x 25-1/2 Leading Edge
TR20A01 1 PARTS BAG-WING PARTS			TR20W03	4	Balsa 3/8 x 3/8 x 25-1/2 Spar
BAL103	4	Balsa 7/16 Wing Leading Edge Filler	TR20W04	4	Balsa 3/32 x 7/8 x 25-1/2 TE Sheet
BAL104	2	Balsa 1/2 Wing Trailing Edge Filler	TR20W05	2	Balsa 3/16 x 1/4 x 25-1/2 TE
HRDWD004	2	Hardwood 5/16 Center Trailing Edge	TR20W06	2	Balsa 1/4 x 15/16 x 22-15/16 Aileron
HRDWD017	2	Hardwood 1/2 x 1 x 3 Wing Hold Down	TR20W07	4	Balsa 3/32 x 2-5/16 x 25-1/2 LE Sheet
TR20A02 1 PARTS BAG-FUSELAGE PARTS					
TR20F16	1	Balsa 1/8 Stabilizer Brace			
TR20F19	2	Balsa 1/4 x 1/2 x 3 Dowel Spacer			
TR20F25	2	Balsa 5/8 Triangle x 2-3/4 Brace			
TR20R01	1	Balsa 3/16 Bottom Rudder			
TR20R02	1	Balsa 3/16 Dorsal Fin			

TRAINER FORTY PARTS LIST

PART NUMBER QTY DESCRIPTION

BAL009	5	Balsa 3/32 X 1/4 X 36 Cap Strips
BAL015	8	Balsa 3/32 x 3 x 7 Cent. Sect. Sheet
BAL016	2	Balsa 1/4 Fin and Rudder
BAL017	1	Balsa 1/4 x 2-1/4 x 22-1/2 Stab
BAL018	1	Balsa 1/4 Stabilizer Front
BAL019	2	Balsa 1/4 Triangle Brace Stock
BAL098	3	Balsa 3/32 x 3 x 11-7/8 Bot. Fuse
BAL105	1	Balsa 1/4 Center Rib, 10" long
MM40D	1	Engine Mount
PLTB002	2	Plastic Pushrod Tubes
PLY3008	1	Plywood 1/4 x 1/2 x 11-3/4 Rails
PLY3010	1	Plywood Servo Rail Spacer Set
TR246P03	1	Instruction Book
TR40F01	2	Balsa 3/16 Fuselage Side
TR40F02	2	Balsa 3/16 Fuselage Doubler
TR40F03	2	Balsa 1/4 x 3/8 x 18 Stringers
TR40F04	2	Plywood 1/4 x 3 x 2-13/16 Bulk.A/ LG Plate
TR40F05	1	Plywood 1/16 x 16-1/2 x 3-1/2 Bot
TR40F06	1	Balsa 3/16 Top Block
TR40F07	2	Balsa 3/16 Cabin Side
TR40F08	2	Balsa 3/16 x 3 x 4-3/4 Bulk B/C
TR40F10	1	Balsa 3/16 Rear Window
TR40F11	1	Balsa 3/16 Front Window
TR40F17	1	Balsa 1/4 x 3/16 x 18 Fuse Brace
TR40F18	1	Balsa 1/2 Hatch
TR40F20	2	Balsa 3/8 Nose Block
TR40P01	1	Plans
TR40S01	2	Balsa 1/4 Elevators
TR40W08	2	Balsa 1-7/8 Tri x 9-7/8 Wing Tip
TR40W09	1	Balsa 3/32 Wing Rib Set
TR40W15	1	Balsa 3/8 x 3/4 x 28-1/2 Wing Shim
WIRES10	1	Wire-36" Threaded Pushrod
WIRES16	2	Wire-12" Threaded Pushrod
WIRES17	2	Wire-34" Threaded Pushrod

TR40A01 1 PARTS BAG-WING PARTS

BAL103	4	Balsa 7/16 Wing Leading Edge Filler
BAL104	2	Balsa 1/2 Wing Trailing Edge Filler
HRDWD004	2	Hardwood 5/16 Center Trailing Edge
HRDWD017	2	Hardwood 1/2 x 1 x 3 Wing Block

TR40A02 1 PARTS BAG-FUSELAGE PARTS

BAL102	1	Balsa 1/4 Dorsal Fin
TR40F16	1	Balsa 1/8 Stabilizer Brace
TR40F19	2	Balsa 1/4 x 1/2 x 3 Dowel Spacer
TR40F25	2	Balsa 5/8 Triangle x 2-5/8 Brace
TR40R01	1	Balsa 1/4 Bottom Rudder

PART NUMBER QTY DESCRIPTION

TR40A03 1 PARTS BAG-FUSELAGE PARTS

DOWEL001	2	Dowel 1/4 Diameter x 4-13/16 HD
HRDWD017	1	Hardwood 1/2 x 1 x 3 Hold Down
PLY3009	2	Plywood 1/4 Rear Hold Down
TR40F12	2	Plywood 1/16 Landing Gear Brace
TR40F15	2	Plywood 1/8 x 1/2 x 2-5/8 Hatch HD

TR40M02 1 PARTS PACKAGE-LANDING GEAR

L-2U	1	Dural Main Landing Gear
WBNT007	1	Wire 5/32 Nose Gear

TR246M03 1 PARTS BAG-HARDWARE

NUTS001	2	4-40 Blind Nuts(use with Hatch)
NUTS003	4	6-32 Blind Nuts(Engine Mount)
NUTS014	4	8-32 Hex Nut(use with Axles)
NYLON03	2	Nylon Control Horn-Small (Rud/Ele)
NYLON09	2	Nylon Hinges/12 ea (Wing, Rud/Ele)
NYLON13	4	Nylon 1/4-20 Wing Bolt
NYLON16	1	Nylon 5/32 Steering Arm (Nosegear)
NYLON17	4	Nylon Clevis(use with all linkages)
NYLON20	2	Nylon Aileron Connector
NYLON21	2	Nylon Aileron Clevis
SCRW002	4	2-56 x 5/8 Screw (Control Horns)
SCRW003	2	4-40 x 1 Bolt(use with Hatch)
SCRW004	4	#4 x 1/2 Screw (Landing Gear)
SCRW005	1	6-32 x 1/8 Screw(5/32 Wheel Collar)
SCRW008	4	6-32 x 1 Bolt(engine mount)
SCRW015	1	4-40 x 1/8 Screw (3/32 Wheel Collar)
SCRW020	1	6-32 x 1/4 Screw (5/32 Wheel Collar)
SCRW035	2	8-32 x 1-1/2 Sockethead Bolt(Axles)
WBNT002	1	Wire 3/32 Aileron Torque Rod Set
WBNT101	1	Wire 1/8 Elevator Joiner
WHCL004	1	3/32 Wheel Collar (Steering Arm)
WHCL005	2	5/32 Wheel Collar(use with Nosegear)

TR40W01 1 PARTS PACKAGE-WING PARTS

TR40W02	2	Balsa 3/8 x 3/8 x 28-1/2 LE
TR40W04	4	Balsa 3/32 x 7/8 x 28-1/2 TE Sheet
TR40W05	2	Balsa 3/16 x 1/4 x 28-1/2 TE
TR40W06	2	Balsa 1/4 x 1-1/16 x 25-7/8 Aileron
TR40W07	4	Balsa 3/32 x 2-7/8 x 28-1/2 LE

TRAINER SIXTY PARTS LIST

PART NUMBER QTY DESCRIPTION

BAL001	8	Balsa 3/32 x 4 x 7-3/4 Cent. Wing Sheet
BAL003	7	Balsa 3/32 X 3/8 X 36 Wing Cap Strips
BAL005	2	Balsa 1/4 Fin and Rudder
BAL007	1	Balsa 3/8 x 2-5/8 x 23-3/4 Stab Rear
BAL008	1	Balsa 3/8 Stabilizer Front
BAL019	3	Balsa 1/4 Triangle Brace Stock
BAL096	2	Balsa 3/8 Elevators
BAL098	3	Balsa 3/32 x 3 x 11-7/8 Bottom Fuse
BAL120	1	Balsa 1/4 Center Rib, 11-1/2" long
MM60D	1	Engine Mount
PLTB002	2	Plastic Pushrod Tubes
PLY3008	1	Plywood 1/4 x 1/2 x 11-3/4 Rails
PLY3010	1	Plywood Servo Spacer Set
TR246P03	1	Instruction Book
TR60F01	2	Balsa 3/16 Fuselage Side
TR60F02	2	Balsa 3/16 Fuselage Doubler
TR60F03	3	Balsa 3/8 x 3/8 x 18 Top Block String
TR60F04	2	Plywood 1/4 x 3-7/16 x 3-3/16 Bulk.A/Landing Gear Plate
TR60F05	1	Plywood 1/16 x 17-7/8 x 3-15/16 Bot
TR60F06	1	Balsa 3/16 Top Block
TR60F07	2	Balsa 3/16 Cabin Side
TR60F08	2	Balsa 1/4 x 3-7/16 x 5-7/16 Bulk B/C
TR60F10	1	Balsa 1/4 Rear Window
TR60F11	1	Balsa 1/4 Front Window
TR60F18	1	Balsa 1/2 Hatch
TR60F20	2	Balsa 3/8 Nose Block
TR60F26	1	Balsa 3/16 x 1/4 x 7 Fuselage Brace
TR60P01	1	Plans
TR60W08	2	Balsa 2-1/8 Triangle x 10-3/4 Wing Tip
TR60W09	1	Balsa 3/32 Wing Rib Set
TR60W15	1	Balsa 3/8 x 7/8 x 31-5/8 Wing Building Shim
WIRES10	1	Wire-36" Threaded Pushrod
WIRES16	2	Wire-12" Threaded Pushrod
WIRES17	2	Wire-34" Threaded Pushrod

TR60A01 1 PARTS BAG-WING PARTS

BAL103	4	Balsa 7/16 Wing Leading Edge Filler
BAL104	2	Balsa 1/2 Wing Trailing Edge Filler
HRDWD004	2	Hardwood 5/16 Center Trailing Edge
HRDWD017	2	Hardwood 1/2 x 1 x 3 Wing Hold Down Block

TR60A02 1 PARTS BAG-FUSELAGE PARTS

BAL102	1	Balsa 1/4 Dorsal Fin
TR60F16	1	Balsa 1/4 Stabilizer Brace
TR60F19	2	Balsa 1/4 x 1/2 x 3-7/16 Dowel Spacer
TR60F25	2	Balsa 5/8 Triangle x 3-1/16 Brace
TR60R01	1	Balsa 1/4 Bottom Rudder

PART NUMBER QTY DESCRIPTION

TR60A03 1 PARTS BAG-FUSELAGE PARTS

PLY3009	2	Plywood 1/4 Rear Hold Down
TR60F09	2	Dowel 1/4 Diameter x 5-1/4 Wing Hold Down
TR60F12	2	Plywood 1/16 Landing Gear Brace
TR60F13	1	Hardwood 1/2 x 1 x 3-7/16 Wing Hold Down
TR60F15	2	Plywood 1/8 x 1/2 x 3-1/16 Hatch Hold Down

TR60M02 1 PARTS PACKAGE-LANDING GEAR

L-3U	1	Dural Main Landing Gear
WBNT075	1	Wire 5/32 Nose Gear

TR246M03 1 PARTS BAG-HARDWARE

NUTS001	2	4-40 Blind Nuts(use with Hatch)
NUTS003	4	6-32 Blind Nuts(Engine Mount)
NUTS014	4	8-32 Hex Nut(use with Axles)
NYLON03	2	Nylon Control Horn-Small(Rud/Ele)
NYLON09	2	Nylon Hinges/12 ea (Wing, Rud/Ele)
NYLON13	4	Nylon 1/4-20 Wing Bolt
NYLON16	1	Nylon 5/32 Steering Arm (Nosegear)
NYLON17	4	Nylon Clevis(use with all linkages)
NYLON20	2	Nylon Aileron Connector
NYLON21	2	Nylon Aileron Clevis
SCRW002	4	2-56 x 5/8 Screw (Control Horns)
SCRW003	2	4-40 x 1 Bolt(use with Hatch)
SCRW004	4	#4 x 1/2 Screw(use with Landing Gear)
SCRW005	1	6-32 x 1/8 Screw(use with 5/32 Wheel Collar)
SCRW008	4	6-32 x 1 Bolt(engine mount)
SCRW015	1	4-40 x 1/8 Screw (3/32 Wheel Collar)
SCRW020	1	6-32 x 1/4 Screw (5/32 Wheel Collar)
SCRW035	2	8-32 x 1-1/2 Sockethead Bolt(Axles)
WBNT002	1	Wire 3/32 Aileron Torque Rod Set
WBNT101	1	Wire 1/8 Elevator Joiner
WHCL004	1	3/32 Wheel Collar (Steering Arm)
WHCL005	2	5/32 Wheel Collar (use with Nosegear)

TR60W01 1 PARTS PACKAGE-WING PARTS

TR60W02	2	Balsa 3/8 x 3/8 x 31-5/16 LE
TR60W03	4	Balsa 3/8 x 1/2 x 31-5/16 Spar
TR60W04	4	Balsa 3/32 x 7/8 x 31-5/8 TE Sheet
TR60W05	2	Balsa 3/16 x 1/4 x 31-5/16 TE
TR60W06	2	Balsa 1/4 x 1-1/4 x 29-1/4 Aileron
TR60W07	4	Balsa 3/32 x 3-1/4 x 31-5/8 LE Sheet

TRAINER PARTS IDENTIFICATION

Use the following drawings to help you identify the parts in this kit (the parts are not drawn to scale). The parts that are not shown here are either sticks or sheets of balsa or plywood parts that are rectangular in shape. The dimensions of these parts for the kit you are building are in the parts list on pages 35, 36 or 37. The parts list also tells you where all the hardware is used like the screws and nylon parts. Write the part names on each of the wood parts as you figure out what they are. Also see the drawing on page 23 in this instruction book to help you with the pushrod linkage installation.

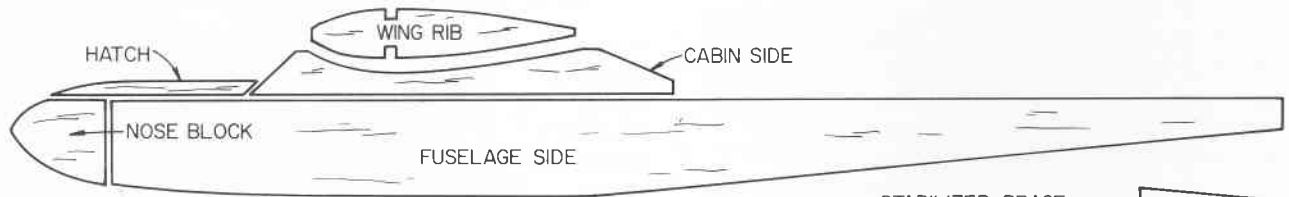

REAR HOLD DOWN

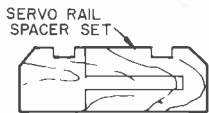
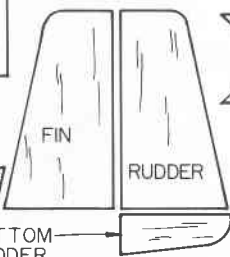

BOTTOM RUDDER



LANDING GEAR BRACE

STABILIZER BRACE

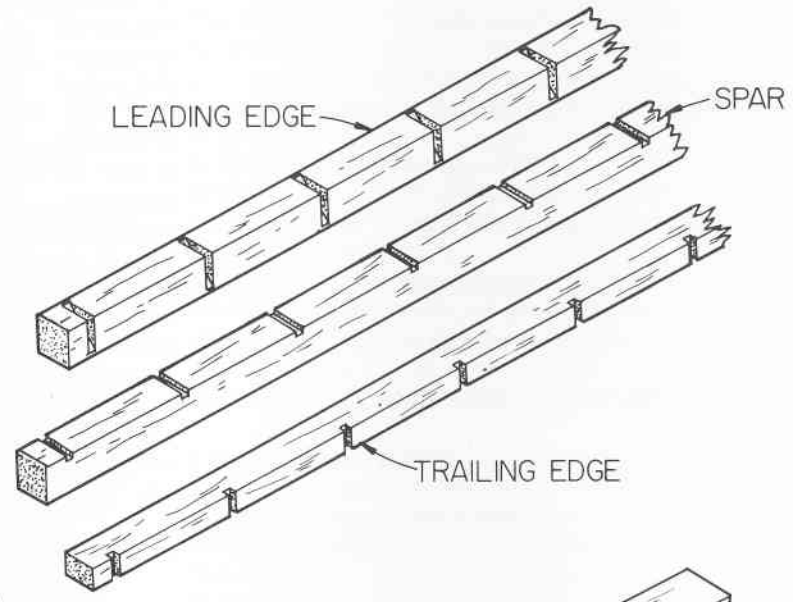
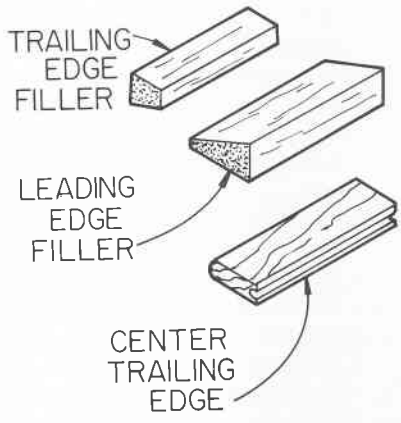
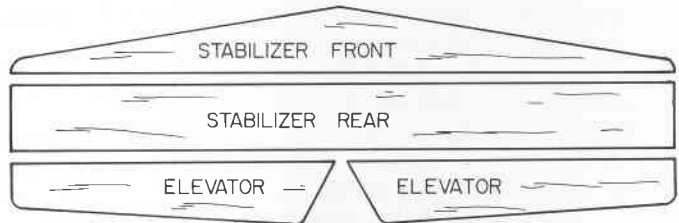

NOT TO SCALE

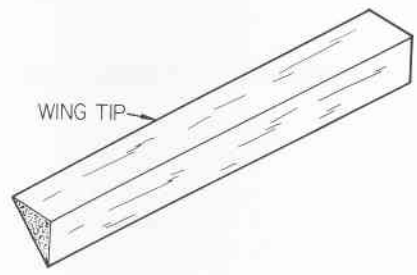
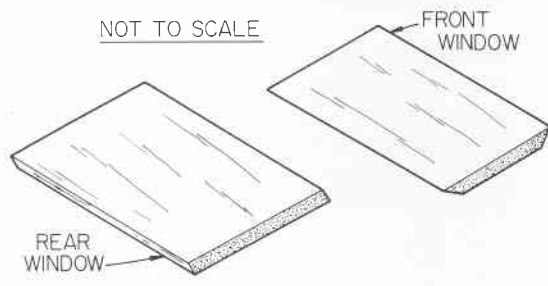

NOTES:

IMPORTANT TIP

In order to insure maximum security at the points where the nylon clevises attach to the nylon elevator and rudder control horns, the following procedure must be observed:

1. Cut two 1/8 inch lengths from your silicone fuel line tubing as shown here.
2. Slide one of the above silicone bands over each of the steel pushrod wires before attaching the nylon clevises.
3. Screw the nylon clevises onto the threaded ends of the steel pushrods.
4. Attach the nylon clevises to the nylon elevator and rudder control horns and snap the clevises shut.
5. Slide the silicone bands over the nylon clevises to insure that they do not pop open during flight.

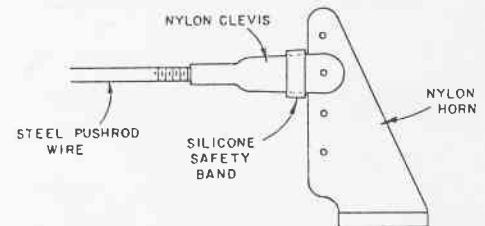
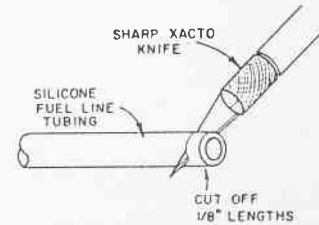

WARNING!

This R/C kit and the model you will build is not a toy! It is capable of serious bodily harm and property damage. **IT IS YOUR RESPONSIBILITY AND YOURS ALONE** — to build this kit correctly, properly install all R/C components and flying gear (engine, tank, pushrods, etc.) and to test the model and fly it *only* with experienced, competent help in accordance with all safety standards and common sense as set down in the Academy of Model Aeronautics Safety Code. It is suggested that you join the AMA and become properly insured before you attempt to fly this model. **IF YOU ARE JUST STARTING R/C MODELING, CONSULT YOUR LOCAL HOBBY SHOP OR WRITE TO THE ACADEMY OF MODEL AERONAUTICS TO FIND AN EXPERIENCED INSTRUCTOR IN YOUR AREA.**

Academy of Model Aeronautics
1810 Samuel Morse Dr.
Reston, VA 22090
(703) 435-0750



P.O. BOX 721 URBANA, ILLINOIS 61801