

TIGER 2

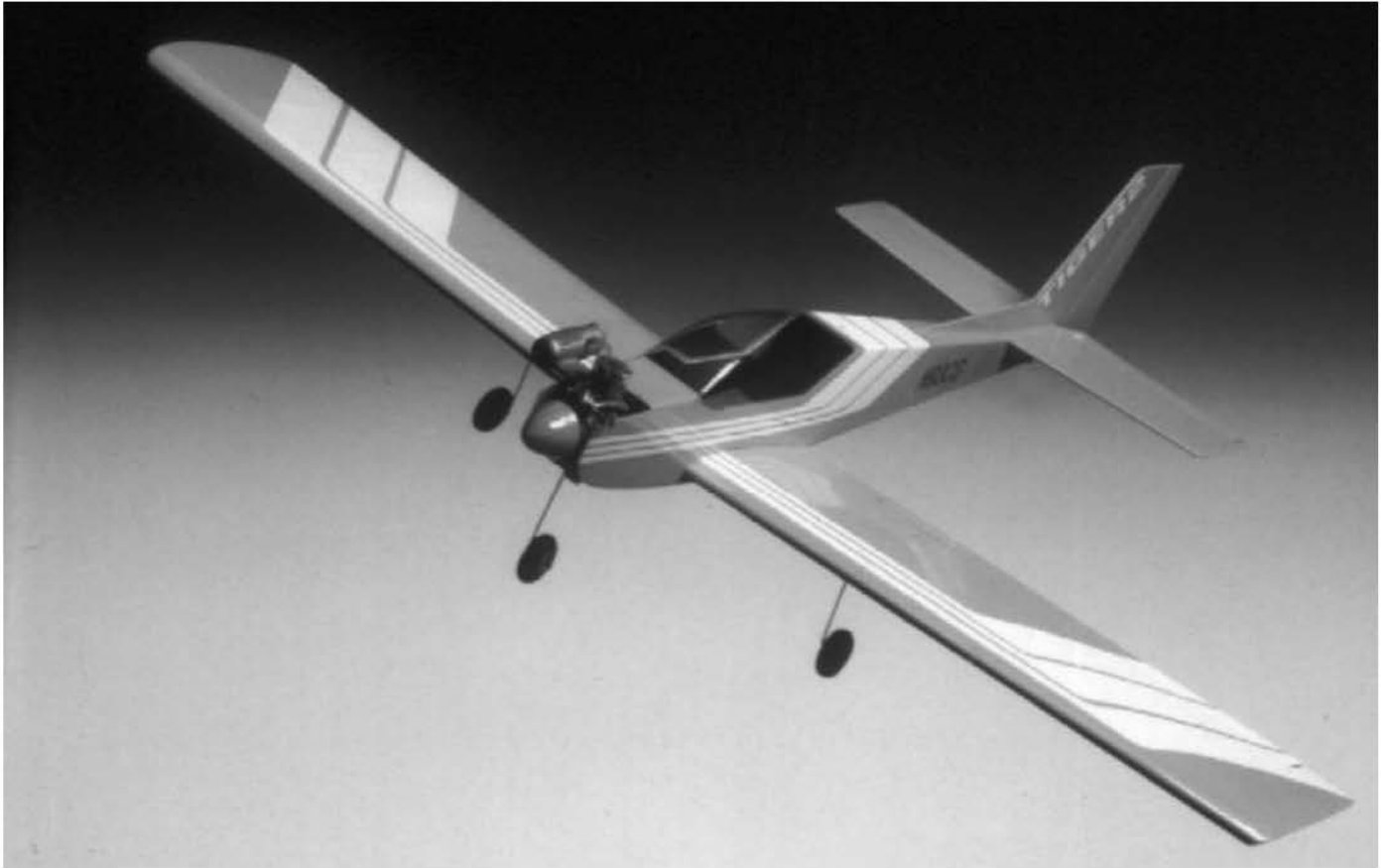

The TIGER 2 is a new breed of cat -- one that has evolved from what many of you knew as the SKY TIGER. This 90's generation aircraft has what it takes to be a good first, low-wing subject, as well as a reliable sport plane. The construction is true-to-form Goldberg, a standard of the industry, engineered for the novice builder with "top gun" performance in his sights. The sure-footed tracking of the take-offs and landings will make your airborne transitions as graceful as the maneuvers in between. And speaking of maneuvers, the TIGER 2 does them all: super smooth loops, four-points, on-a-wire axial rolls and ...oooh... inverted flight. So, let's get going! But before you lose yourself in the joys of building, do a read-through of these instructions and look at the plans. We're sure that you will find building and flying the TIGER 2 absolutely Grrrrrrreat!

WARNING!

A radio-controlled model is not a toy and is not intended for persons under 16 years old. Keep this kit out of the reach of younger children, as it contains parts that could be dangerous. A radio-controlled model is capable of causing serious bodily injury and property damage. It is the buyer's responsibility to build this kit correctly and to properly install the motor, radio, and all other equipment. Test and fly the finished model only in the presence and with the assistance of another experienced R/C flyer. The model must always be operated and flown using great care and common sense, as well as in accordance with the safety standards of the Academy of Model Aeronautics (5151 Memorial Drive, Muncie, IN 47302, 1-800-435-9262). We suggest you join the AMA and become properly insured prior to flying this model. Also, consult with the AMA or your local hobby dealer to find an experienced instructor in your area. Per the Federal Communications Commission, you are required to use only those radio frequencies specified "for Model Aircraft."

Carl Goldberg Products, LTD.

P.O. Box 818 4462 Oakwood Rd. Oakwood, GA 30566
Fax # 770-532-2163 www.carlgoldbergproducts.com

Ph # 678-450-0085

Pt. # 2049 08/02

©copyright 1993

ITEMS NEEDED TO COMPLETE THIS KIT

- 1 RADIO GUIDANCE SYSTEM (4 CHANNEL MINIMUM REQUIRED)
- 1 ENGINE (.35-.45 2 CYCLE, .40-.50 CYCLE)
- 1 PROPELLER TO MATCH ENGINE
- 1 6-8 OZ. FUEL TANK
- 1 12" FUEL LINE
- 3 2-1/4" DIAMETER WHEELS
- 2 ROLLS ULTRACOTE®
- 1 CGM 2-1/4" DIAMETER SPINNER
- 1 2 OZ. BOTTLE SUPER JET™ GLUE
- 1 JET 20 EPOXY™
- 1 TUBE TINTED JET MODEL MATE™
- 1 PIECE CGM 1/2" FOAM PADDING
- 6 5/32" WHEEL COLLARS

UltraCote is a registered trademark of Horizon Hobby Distributors

TOOLS & SUPPLIES REQUIRED FOR ASSEMBLY

- MISCELLANEOUS RUBBER BANDS (INCLUDING #64)
- ROLL OF WAXED PAPER
- SANDPAPER (ASSORTED GRITS, INCLUDING MEDIUM (150) AND FINE (220))
- SANDING BLOCK
- "T" PINS (at least 50)
- X-ACTO MODELING KNIFE
- SINGLE EDGE RAZOR BLADE
- RAZOR SAW
- BUILDING BOARD (24" x 62")
- BUILDING BOARD (12" x 24")
- ELECTRIC DRILL
- 1/4", 1/8", 1/16", 3/32", 5/32" DRILL BIT
- SMALL SCREWDRIVER
- COVERING IRON AND HEAT GUN
- MASKING TAPE
- PLIERS
- YARD STICK
- 6" RULER
- 30-60 DEGREE x 6" TRIANGLE
- PENCIL
- HAMMER

LIMITED WARRANTY

Carl Goldberg takes pride in the care and attention given to the manufacture of components for its model airplane kits. The company warrants replacement of any materials found to be defective for their intended use, **prior to their use in construction of the aircraft**, provided the buyer requests such replacement within a period of one year from the date of purchase and provided the defective part is returned, if so requested by the company.

No other warranty, expressed or implied, is made by the company with respect to this kit. The buyer acknowledges and understands that it is his responsibility to carefully construct a finished flying model airplane and to fly it safely. The buyer hereby assumes full responsibility for the risk and all liability for personal or property damage or injury arising out of the buyer's use of the components of this kit.

INTRODUCTION

USING THIS INSTRUCTION MANUAL

Before you start gluing and sanding, take some time becoming familiar with the plans and looking through this entire Instruction Booklet. It is designed to guide you through the construction process step by step, so build in the order given in this book. Building options, as well as balancing, set-up, and flying the model are covered.

Like a full-size airplane, the **TIGER 2** is built from basic structures (stabilizer, fin, wing, etc.), which are then assembled into the complete airplane.

Special procedures or comments will usually be explained before a step, so you will be prepared. If a step begins with a statement like "Note," "Warning," or "Important," it is a good idea to read through the step before doing it.

A check-off box appears at the beginning of each step. Check these boxes as you build, so you can tell at a glance what steps you have completed. Some steps are repeated and must be marked twice, as in the case of the left and right wing panel.

Some of the instructions deal with general procedures. Boxes are not needed for these sections.

HOW TO READ THE PLAN

The plan sheet in this kit shows the Fuselage (Body), the Wing, and the Tail Parts. Everything on the plan is drawn to full-size and shape and shows how the finished parts fit together.

The plan is drawn to show the model completely assembled, but as a result, the areas inside or underneath are covered up, making it hard to understand how these parts fit together. Therefore, for clarity, some parts are drawn with hidden lines, others with breakaway views, and some are entirely removed from the structure and shown separately.

For example, on the fuselage, the left side of the completed model has been removed to show the details inside. Sometimes a surface is broken away to reveal the detail behind or underneath. Dashed lines indicate details that are hidden behind or under another part of the surface.

The model is made from four varieties of wood: balsa, bass, birch, and various plywoods. Each kind of wood has its own characteristic end grain pattern (as viewed from the end) which has been drawn in this book. You can easily use these end grain patterns to identify what kind of wood is shown for a part, if you are in doubt.

HOW TO USE THE PLAN

The plan is used in several ways. The wings, stabilizer, and fin are assembled directly over the plan. Each wood part is matched over its corresponding location printed on the plan and pinned in place. To prevent ruining your plan from gluing your wings, etc. to it, cover the area you are working on with waxed paper.

The paper the plan is printed on can expand or contract slightly with changes in temperature or humidity. Because of this, a preformed part, such as the notched wing trailing edge, may not exactly match the plan. This is no problem, as slight deviations in the outline or size will not noticeably affect flight performance.

Because the fuselage plugs together and is self-aligning, it is not built directly over the plan. As you assemble the fuselage, you will find the plan helpful in identifying parts and how things fit together. The plan also shows the installation of a typical radio, battery and all remaining equipment and hardware needed to complete the model. By referring to the examples shown, you should be able to install your own radio, etc., even if it is not the same as what is shown on the plan.

IDENTIFYING PARTS

Parts for the wing are bundled together; likewise, parts for the tail assembly are also grouped. Die-cut plywood and balsa sheets of common sizes are bundled together, so they are less likely to be damaged during shipping and handling.

The various screws, hinges, and fittings are packaged in plastic bags.

PREPARING FOR ASSEMBLY

Set a flat, warp-free pinning board on your work bench. Any material that accepts pins, such as insulation board, soft plywood, or dry-wall (sheet rock) will work. Important: any warps or bends in the pinning board will result in wings or tail surfaces that are also warped or bent, making your model more difficult to fly. Make sure that the pinning board is flat by laying a straight edge across it. You may be able to correct a warped board by shimming its low areas.

Position the area of the plan (such as the stabilizer) on which you are going to build over the pinning board and tape it in place so the plan lays flat and wrinkle free.

Place a sheet of waxed paper or plastic kitchen wrap over the work area to prevent Super Jet from sticking to your plan and ruining it.

In assembling your model, the following tips will prove helpful.

IMPORTANT: ALWAYS READ A FEW STEPS AHEAD. This will alert you to coming instructions and will help you plan accordingly.

You may find it convenient to empty all of the small parts from the hardware bags into a common container, such as a margarine tub. This will help you find items quickly.

When drilling any 1/16" holes in balsa, you may find it easier to twist the drill between your thumb and index finger. This procedure allows more control in positioning the drill on the center mark.

Punch out only the die-cut (D/C) parts you need as you proceed. This will help you keep track of parts, especially the small ones.

Sometimes you will be asked to "tack cement" a piece of wood that will later be taken apart. To provide for easy removal without damage, use only a small drop of glue.

After completing each section of the aircraft, you may want to go back and reglue the joints, just in case some area has been missed. Be careful not to use too little glue, which will leave the model weak, or too much glue, which can make the model heavy. Properly glued joints are important to the overall strength of the model. Super Jet™ is recommended for most parts of the assembly, although Jet Epoxy may be used when more time is needed for careful placement.

WOOD PARTS

Be careful when removing parts (such as fuselage sides) from the die-cut sheets. Long parts are fragile until Super Jetted into a structural unit. If necessary, use a razor knife or razor saw to assist in the removal of parts from the sheet. Sometimes a little trimming and sanding can improve parts, where desired. Save scrap until the model is completed, in case a part is missing or damaged. Also, scrap is used in some building steps.

ABOUT THE WOOD IN THE KIT

We strive to supply good quality materials in your kit. Wood parts are inspected with regard to the function they will serve. If an imperfection is spotted in a scrap corner of a die-cut sheet and doesn't affect actual parts, the sheet is considered acceptable. Also, internal stresses in wood are relieved as it is cut into parts. These relieved stresses may cause some parts to bow. Bows in wood parts (such as leading edges) readily straighten out as they are Super Jetted into a structural unit.

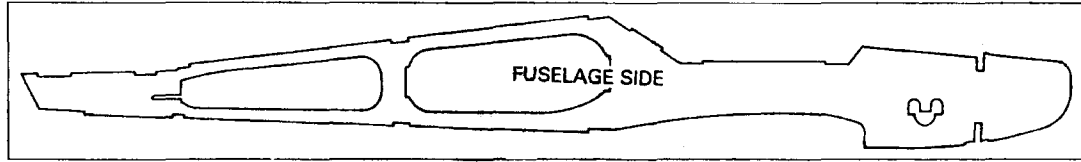

PT. #3570, D/C SHT. 6601 (2 REQ'D)

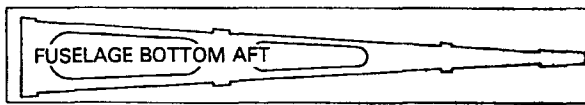

PT. #3571, D/C SHT. 6602 (1 REQ'D)

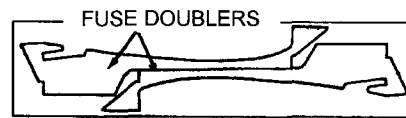

PT. #3587, D/C SHT. #6620 (1 REQ'D)

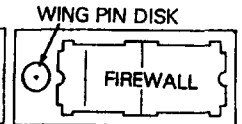

PT. #3576, D/C SHT. 6607 (1 REQ'D)

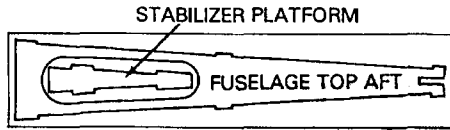

PT. #3572, D/C SHT. 6603 (1 REQ'D)

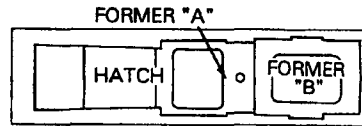

PT. #3575, D/C SHT. 6606 (1 REQ'D)

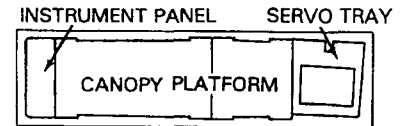

PT. #3574, D/C SHT. 6605 (1 REQ'D)

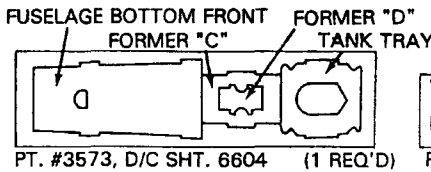

PT. #3573, D/C SHT. 6604 (1 REQ'D)

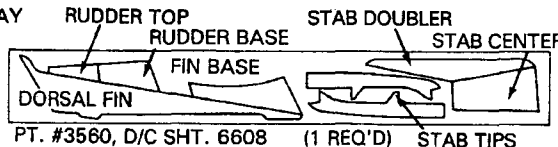

PT. #3560, D/C SHT. 6608 (1 REQ'D)

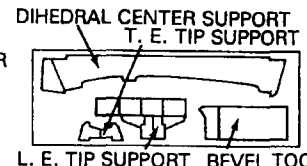

PT. #3580, D/C SHT. 6615 (1 REQ'D)

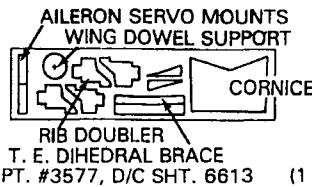

PT. #3577, D/C SHT. 6613 (1 REQ'D)

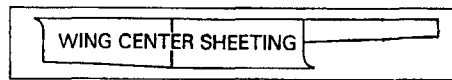

PT. #3584, D/C SHT. 6612 (4 REQ'D)



PT. #3583, D/C SHT. 6611 (1 REQ'D)

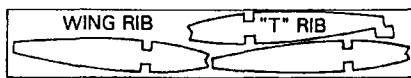

PT. #3581, D/C SHT. 6609 (4 REQ'D)

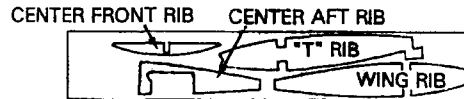

PT. #3582, D/C SHT. 6610 (2 REQ'D)



PT. #3579, D/C SHT. 6614 (1 REQ'D)

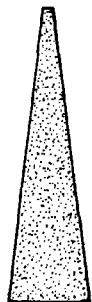

AILERON
(2 REQ'D)



SHAPED L. E.
(2 REQ'D)



NOTCHED T. E.
(2 REQ'D)



3/8" SQ. x 29-1/16" BASSWOOD
(4 REQ'D)



1/8" x 1/4" x 24" Balsa
(3 REQ'D)



1/4" x 1/2" x 12" Balsa
(7 REQ'D)



1/4" x 1/2" x 22" Balsa
(1 REQ'D)



1/16" x 1/4" x 16" Balsa
(8 REQ'D)

HORIZONTAL STABILIZER CONSTRUCTION (15 Steps)

1. Collect all of the parts you will need to construct the HORIZONTAL STABILIZER.

THEY INCLUDE:

- (1) STAB CENTER (1/4" Balsa) PT. #3560, D/C SHT. 6608
- (1) STAB DOUBLER (1/4" Balsa) PT. #3560, D/C SHT. 6608
- (2) STAB TIPS (1/4" Balsa) PT. #3560, D/C SHT. 6608
- (1) BEVEL TOOL (.110" LITE-PLY) PT. #3579, D/C SHT. 6614
- (1) RADIUS TOOL (.110" LITE-PLY) PT. #3580, D/C SHT. 6615
- (1) HINGE STICK (1/4" x 1/2" x 22" Balsa) PT. #4881
- (3) L.E. & BRACE (1/4" x 1/2" x 12" Balsa) PT. #4880
- (2) TRUSS STICK (1/8" x 1/4" x 24" Balsa) PT. #4882

- (1) ELEVATOR (1/4" x 1-1/2" x 22" Balsa) PT. #4897
- (1) ELEVATOR JOINER (3/32" x 3-3/4" Wire) PT. #1251
- (1) CENTERLINE MARKER PT. #1425
- (4) FLEX-POINT HINGE PT. #1449
- (1) PLAN PT. #2048

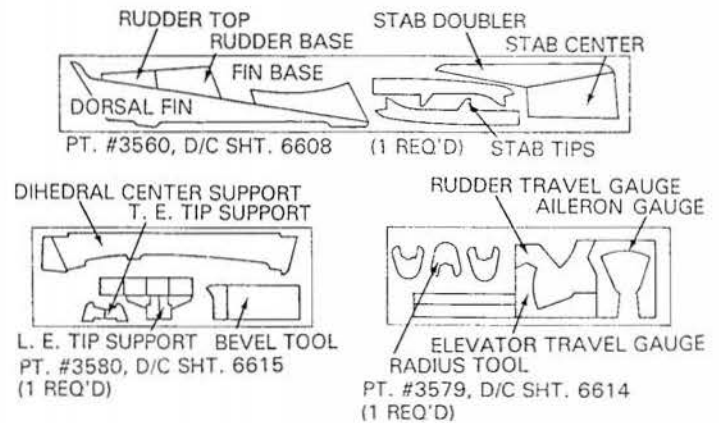

2. Lay the horizontal stabilizer portion of the plan over the building board.
- Place the waxed paper over the plan.
- Pin the HINGE STICK over the plan, flush with the left edge. Trim the right end flush with the plan.

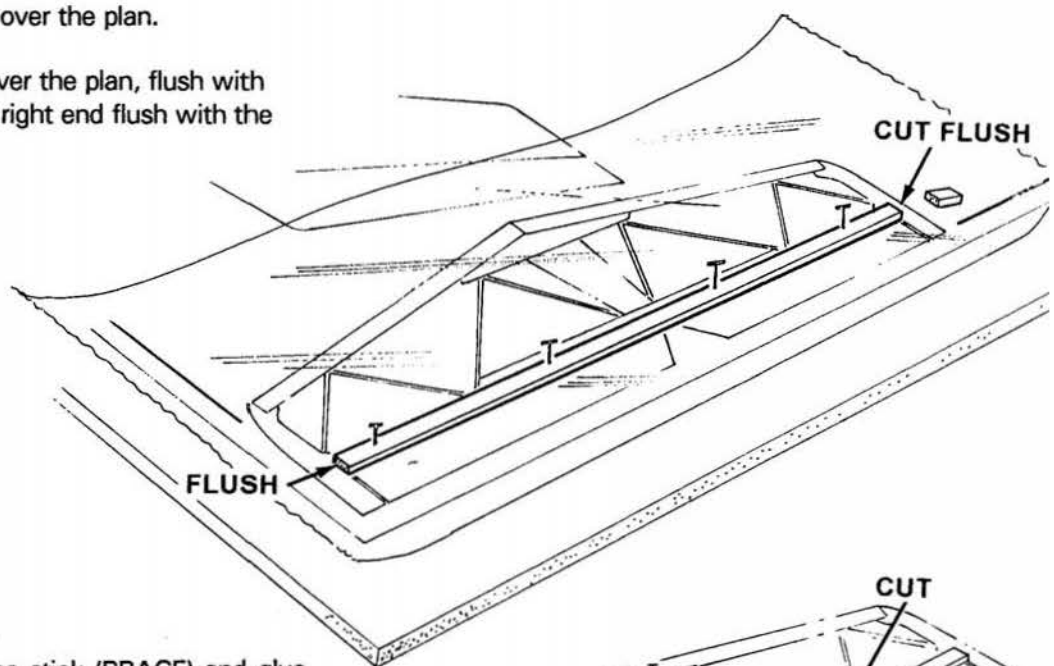

3. Trim a 1/4" x 1/2" balsa stick (BRACE) and glue to the hinge stick.
- Glue and pin the STAB CENTER to the STAB DOUBLER.
- Glue the CENTER/DOUBLER ASSEMBLY to the brace.

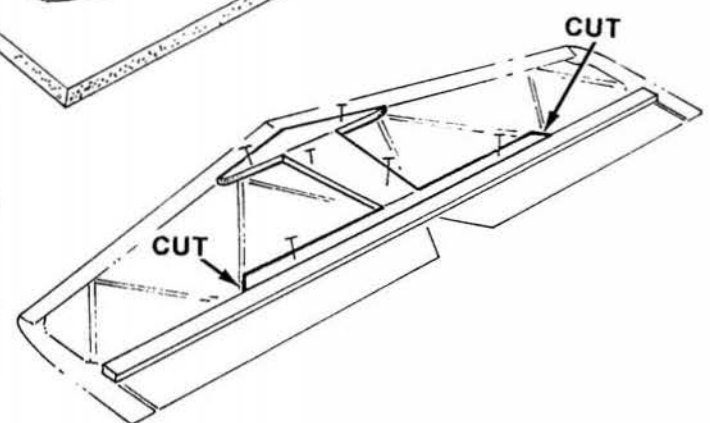

4. Trim and glue the two LEADING EDGE parts to the STAB DOUBLER .

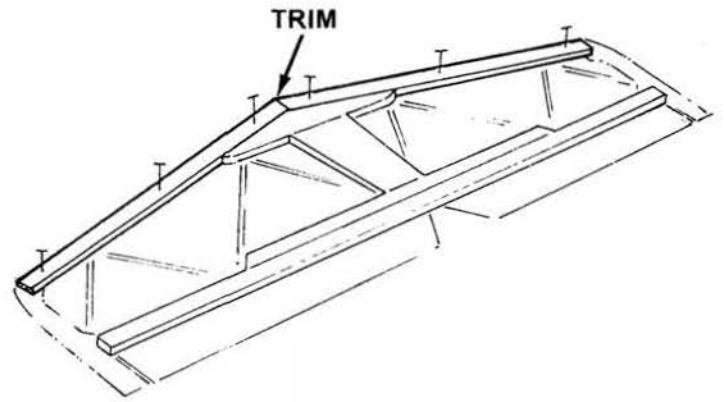

5. Glue the STAB TIPS to the leading edge and hinge stick.

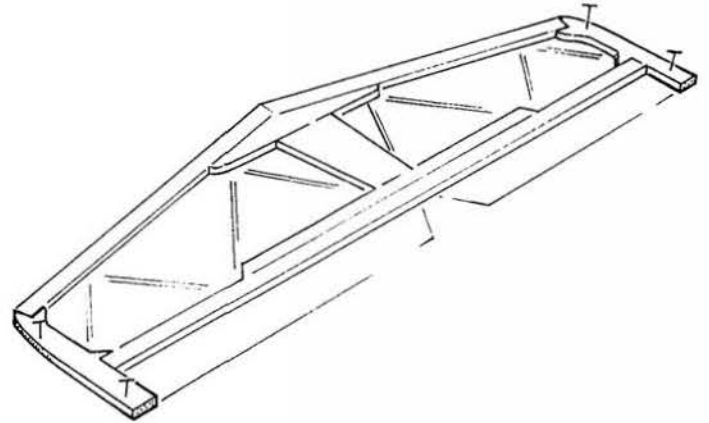

6. Trim to fit and glue the TRUSS STICKS into place.

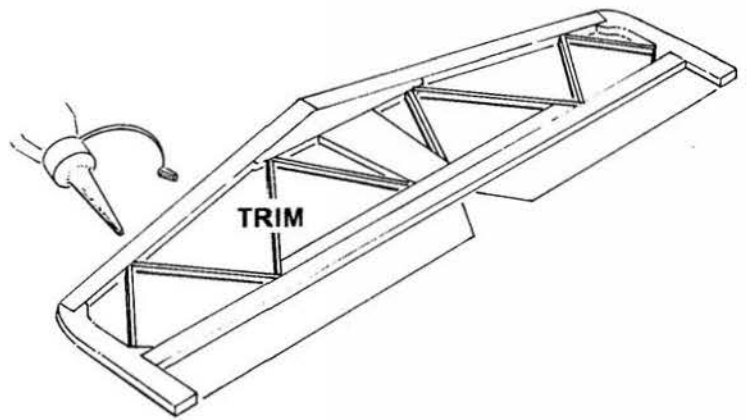

7. Bump the right end of the ELEVATOR against the inside of the STAB TIP. Measure 1/8" from the inside of the left tip, and cut.

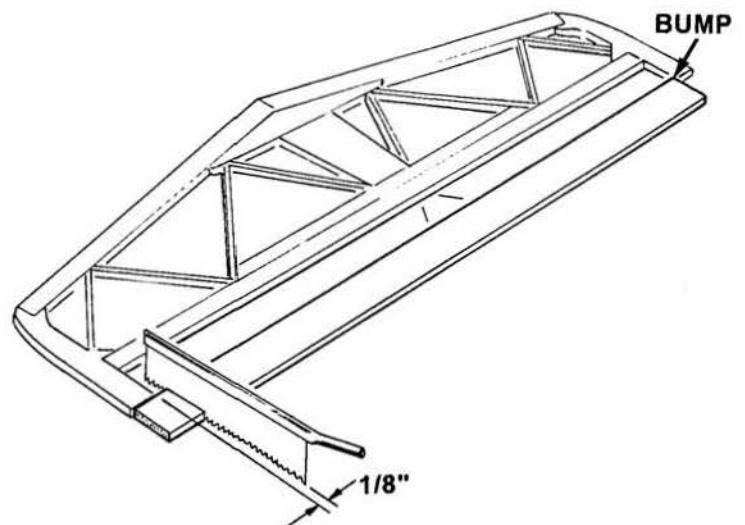

8. Transfer the 4 hinge locations from the plan. Use the CENTERLINE MARKER to scribe a line down the center of the stab and elevator.

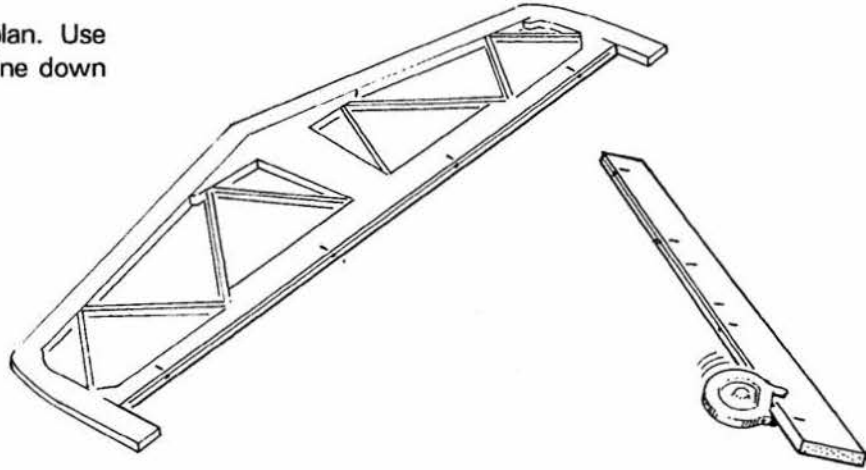

9. Use an X-acto knife to slot each side of the holes for hinge. Test each hinge location for the correct fit as you go.

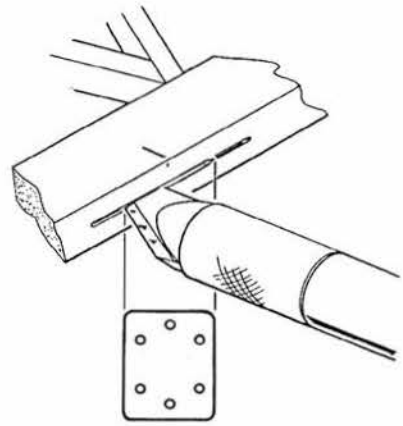

10. Assemble the BEVEL TOOL and tack-glue a piece of **medium** sandpaper onto the small board.

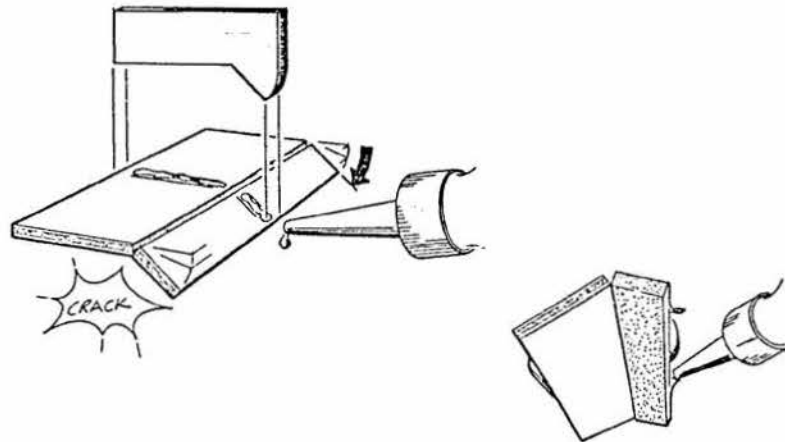

11. Use the bevel tool to sand the hinge side of the elevator. Sand both sides until a symmetrical bevel is formed along the entire length.

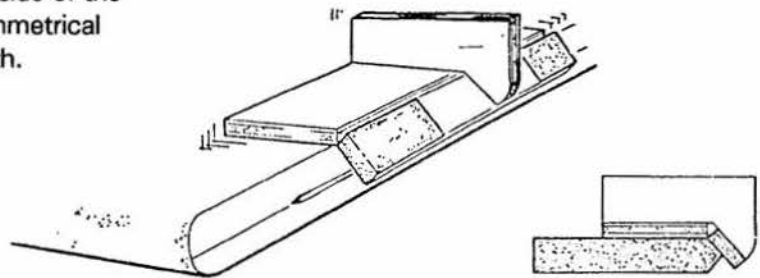

LIKE THIS

12. Bend the 3/32" x 3-3/4" ELEVATOR JOINER WIRE to the template shape. Make sure the wire lies flat after forming!

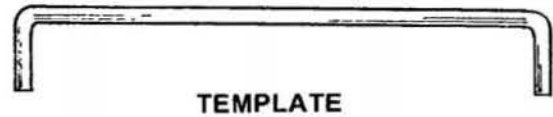

13. Drill two 3/32" diameter holes, using the plan and the formed wire to determine the location. Carve out the clearance for the back of the wire form. **Epoxy** the wire into the holes and let it dry.

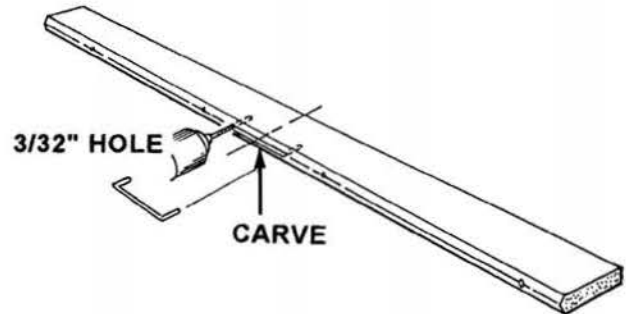

14. Temporarily install the hinges and fit the stab to the elevator. With the parts over the plan, cut out the "V"-shaped piece that separates the elevators.

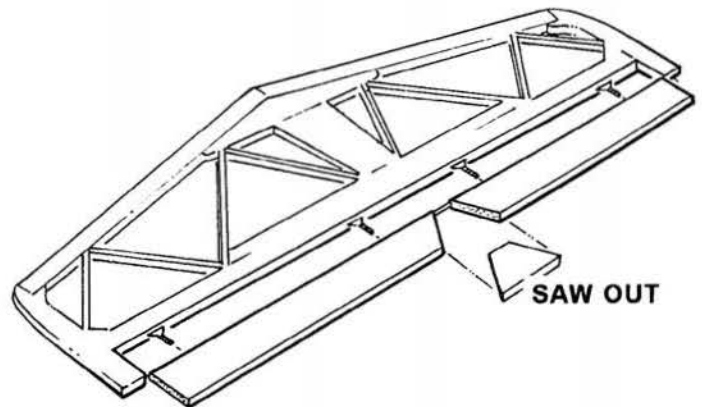

15. Build the RADIUS TOOL and insert a piece of **medium** sand paper. Use the tool to round the entire perimeter of the horizontal stabilizer. Remove the medium sandpaper and insert a piece of **fine** sandpaper and repeat. Use a sanding block with **fine** sandpaper to flat-sand both sides of the assembly.

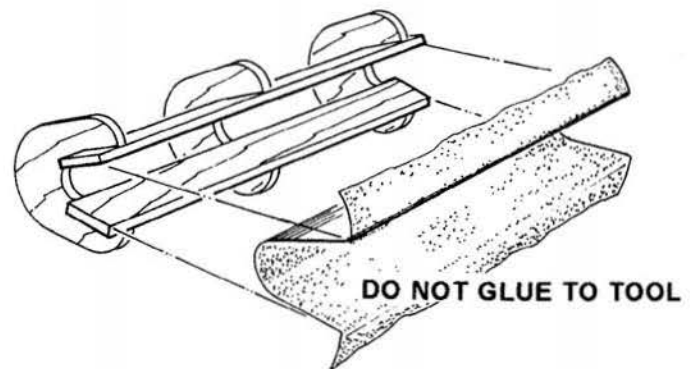

THIS COMPLETES THE HORIZONTAL STAB AND ELEVATOR. YOU MAY PUT THEM ASIDE UNTIL YOU ARE READY FOR COVERING. NOW LET'S MOVE ON TO THE FIN AND RUDDER

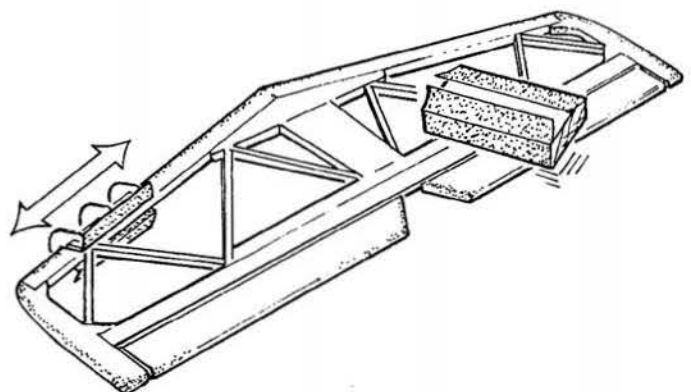

VERTICAL FIN & RUDDER CONSTRUCTION (8 Steps)

1. Collect all of the parts you will need to construct the VERTICAL FIN & RUDDER.

THEY INCLUDE:

- (1) DORSAL (1/4" BALSA) PT. #3560, D/C SHT. 6608
- (1) FIN BASE (1/4" BALSA) PT. #3560, D/C SHT. 6608
- (1) RUDDER BASE (1/4" BALSA) PT. #3560, D/C SHT. 6608
- (1) RUDDER TOP (1/4" BALSA) PT. #3560, D/C SHT. 6608
- (4) STICK (1/4" X 1/2" X 12" BALSA) PT. #4880
- (1) TRUSS STICK (1/8" X 1/4" X 24" BALSA) PT. #4882
- (3) FLEX-POINT HINGE PT. # 1449

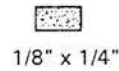
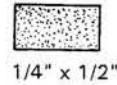
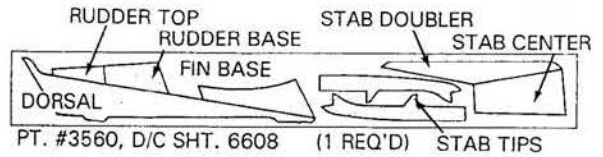

2. Lay the vertical fin portion of the plan over the building board, and cover with waxed paper.
- Pin and glue the DORSAL, L.E., FIN BASE, and HINGE STICK over the plan.

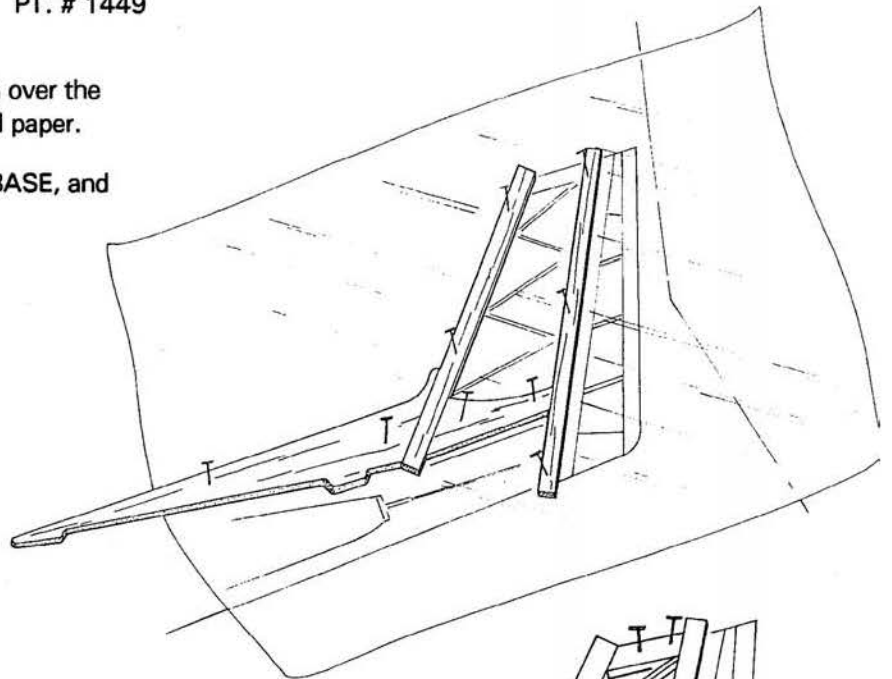

3. Trim to fit the 1/4" x 1/2" balsa FIN TOP and the 1/8" x 1/4" balsa TRUSS STICKS. Pin and glue in place.

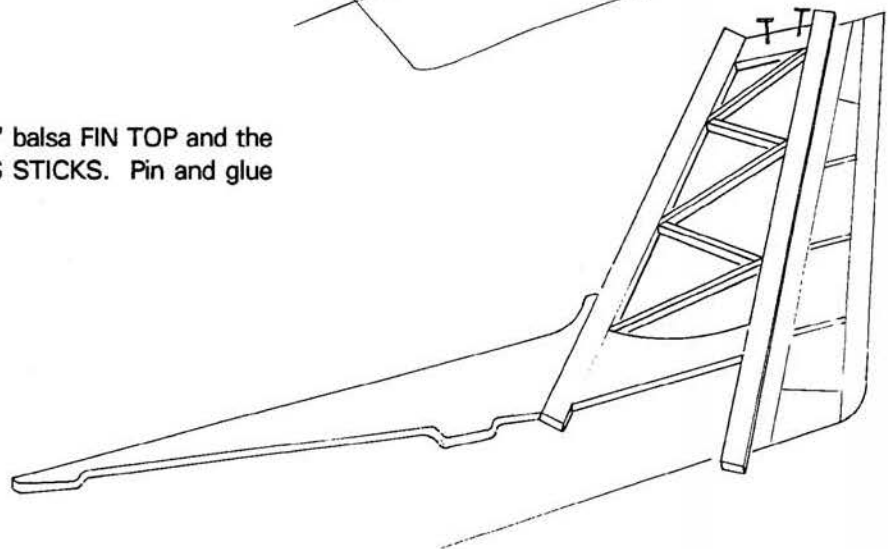

4. Trim, pin and glue the RUDDER parts together over the plan.

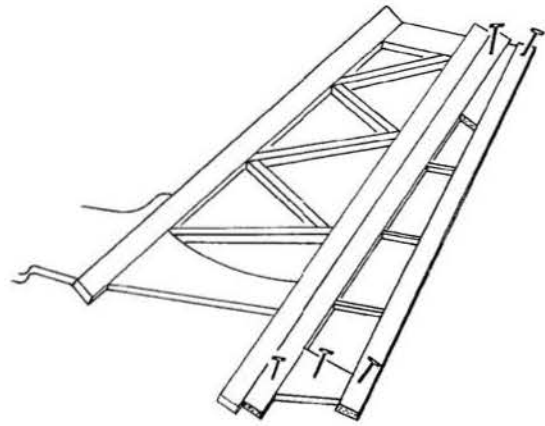

5. Use a razor saw to trim the ends. Use an X-acto knife to trim the DORSAL.

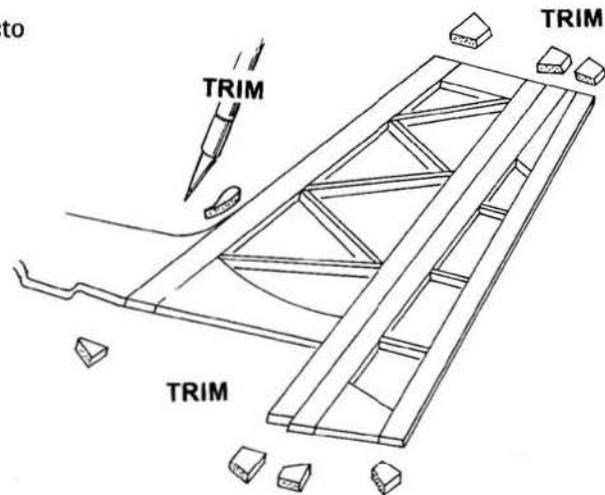

6. Transfer the hinge locations from the plans to the fin and rudder. Use the marking tool to scribe the centerline.

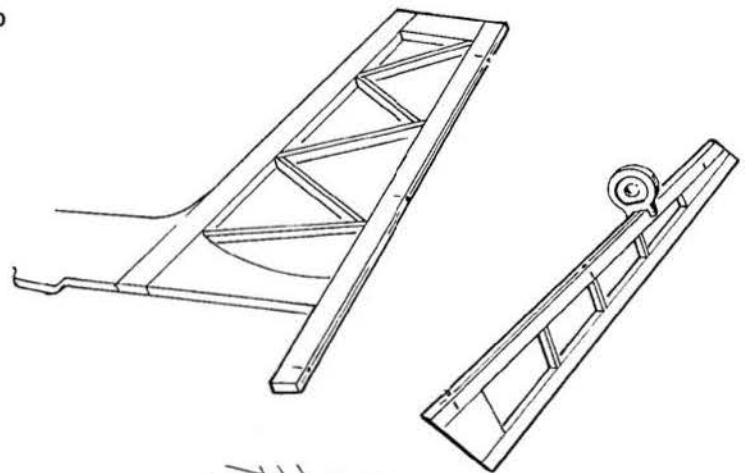

- Slot all hinge locations like you did before.

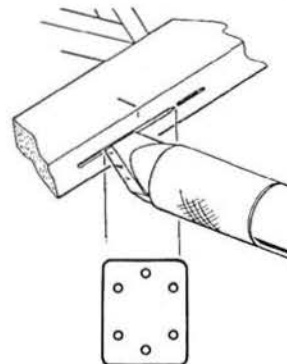

7. Use the bevel tool to bevel both sides of the hinge-side of the rudder.

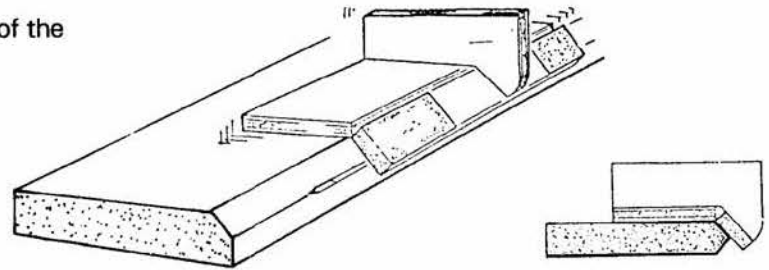

- Temporarily install the hinges and fit the rudder to the fin.

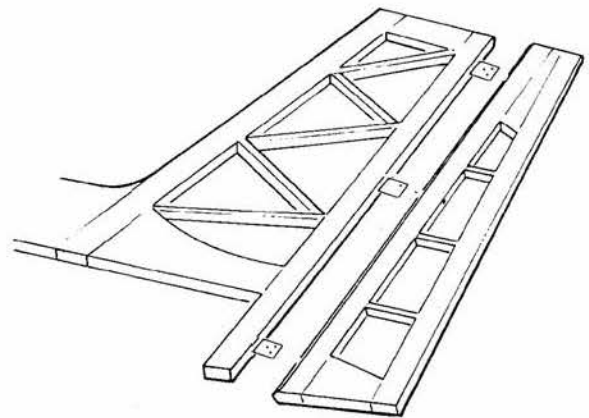

8. Use the rounding tool to round the perimeter segment "A" to "B". Flat-sand both sides of the fin/rudder.

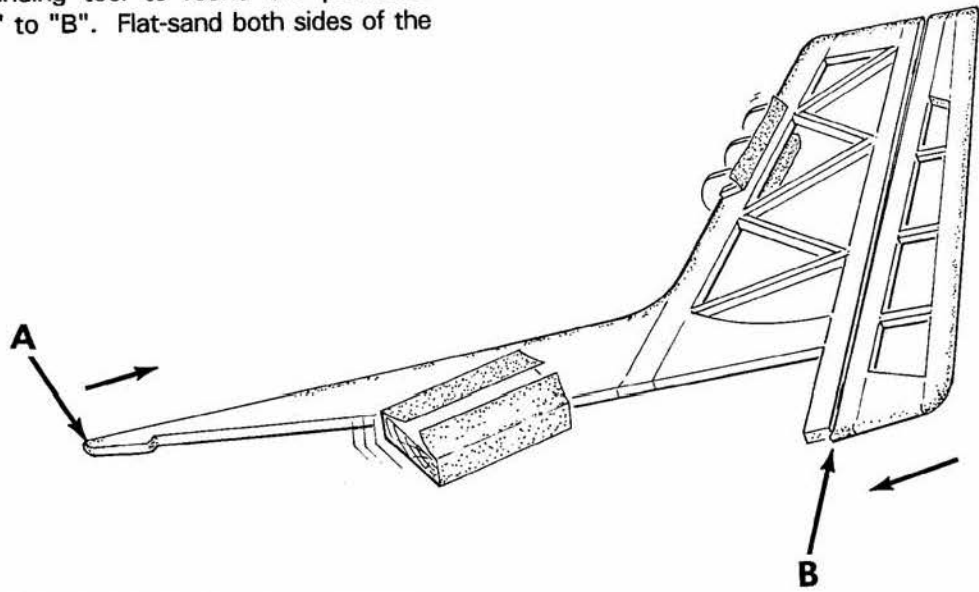

THIS COMPLETES THE FIN AND RUDDER. YOU WILL NOT NEED THESE PARTS UNTIL YOU ARE READY FOR THE COVERING, SO PUT THEM WITH THE HORIZONTAL STAB UNTIL THEN.

WING CONSTRUCTION (32 Steps)

1. Collect the parts needed to construct the WING.

THEY INCLUDE:

- (4) WING RIB SHEET (BALSA) PT. #3581, D/C SHT. 6609
- (2) WING RIB SHEET (BALSA) PT. #3582, D/C SHT. 6610
- (1) SHEAR WEBS (BALSA) PT. #3583, D/C SHT. 6611
- (4) CENTER SHEETING (BALSA) PT. #3584, D/C SHT. 6612
- (4) RIB DOUBLER (LITE PLY) PT. #3577, D/C SHT. 6613
- (1) T.E. DIHEDRAL BRACE (LITE PLY) PT. #3577, D/C SHT. 6613
- (1) WING DOWEL SUPPORT (LITE PLY) PT. #3577, D/C SHT. 6613
- (1) DIHEDRAL CENTER SUPPORT (LITE PLY) PT. #3580, D/C SHT. 6615
- (2) WING TIP T.E. SUPPORT (LITE PLY) PT. #3579, D/C SHT. 6614
- (2) WING TIP L.E. SUPPORT (LITE PLY) PT. #3579, D/C SHT. 6614
- (1) WING PIN (1/4" X 3-1/4" BIRCH DOWEL) PT. #1757
- (2) SHAPED L.E. (SHAPED BALSA) PT. #4885
- SPAR (3/8" SQ. x 29-1/6" BASSWOOD) PT. #4883
- (2) NOTCHED T.E. (SHAPED BALSA) PT. #4878
- (2) INBOARD T.E. (6" SHAPED BALSA) PT. #4879
- (2) AILERON (22" SHAPED BALSA) PT. #4898
- (2) TIP TRAILING EDGE (1" SHAPED BALSA) PT. #4873

- (4) L.E. SHEETING (2-7/8" x 29-1/4" BALSA) PT. #5000
- (4) T.E. SHEETING (1-1/4" x 29-1/4" BALSA) PT. #5001
- (2) WING TIP (1-1/2" TRI x 12" BALSA) PT. #4877
- (2) LANDING GEAR SUPPORT (1/4"x1"x 3-13/16" PLY) PT. #4899
- (2) TORQUE SUPPORT (1/4" x 3/4" SQ. PLY) PT. #4900
- (8) CAPSTRIPS (1/16" x 1/4" x 16" BALSA) PT. #4884
- (2) AILERON TORQUE RODS PT. #5801
- (2) BRASS BEARING PT. #5800
- (8) FLEX-POINT HINGE PT. #1449
- (1) NYLON FABRIC PT. #1675

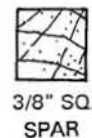
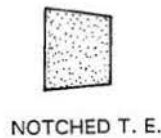
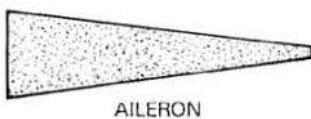
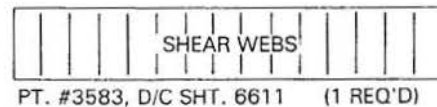
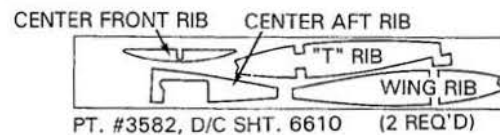
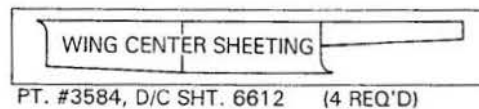
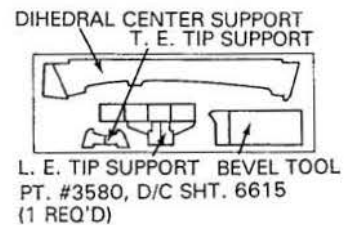

2. Lay the entire wing plan over the building board and completely cover with a sheet of waxed paper.
3. Place the NOTCHED TRAILING EDGE over the plan. Align the notches to the plan and cut off along the wing centerline. **Make sure that you align and cut the correct end.**

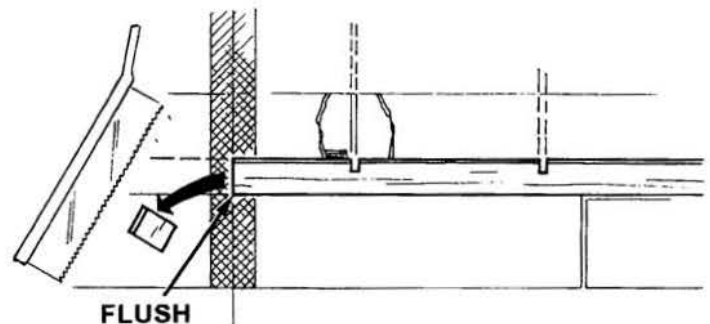

4. Wrap a piece of **fine** sandpaper around the 1/4" WING PIN and use as a sanding tool to sand the wing pin clearance into the end of the shaped LEADING EDGE.

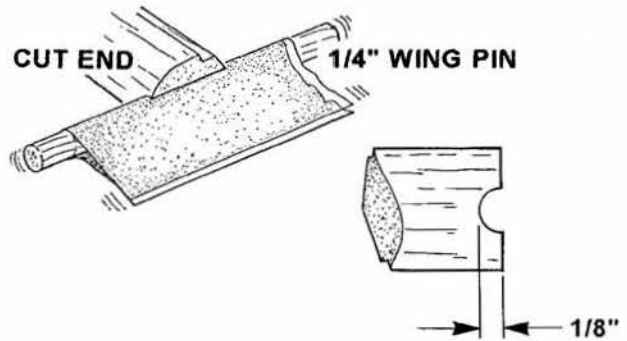

5. Scissors-pin a basswood SPAR over the plan. Make sure that the end is on the wing centerline.

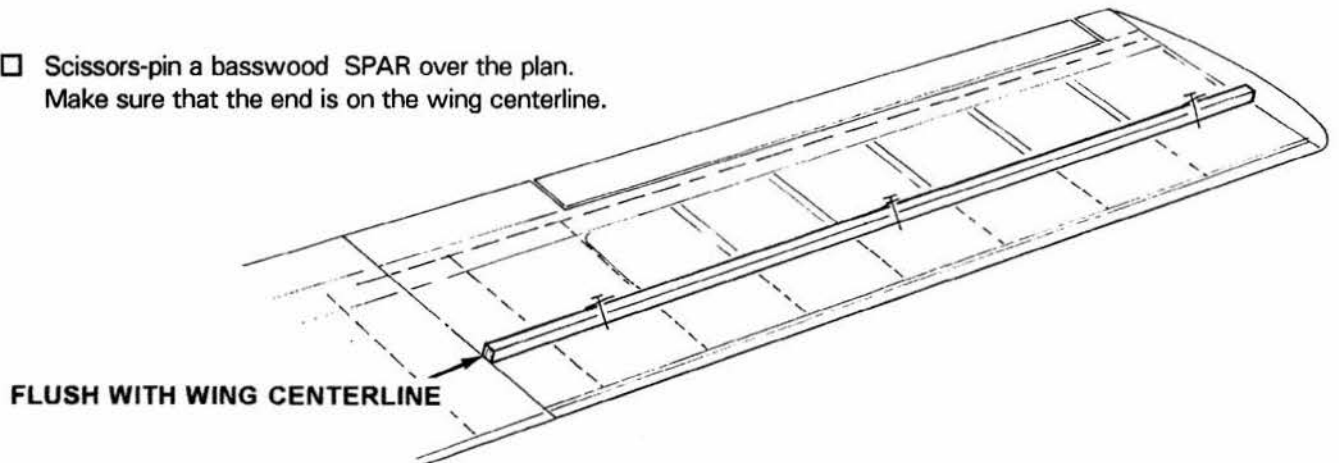

6. **Pin** the tabbed ribs, "T", at the "T" locations, over the plan. **DO NOT GLUE THEM TO THE SPAR AT THIS TIME.**
- Tape over tab break-off line on both sides of the tabbed ribs.

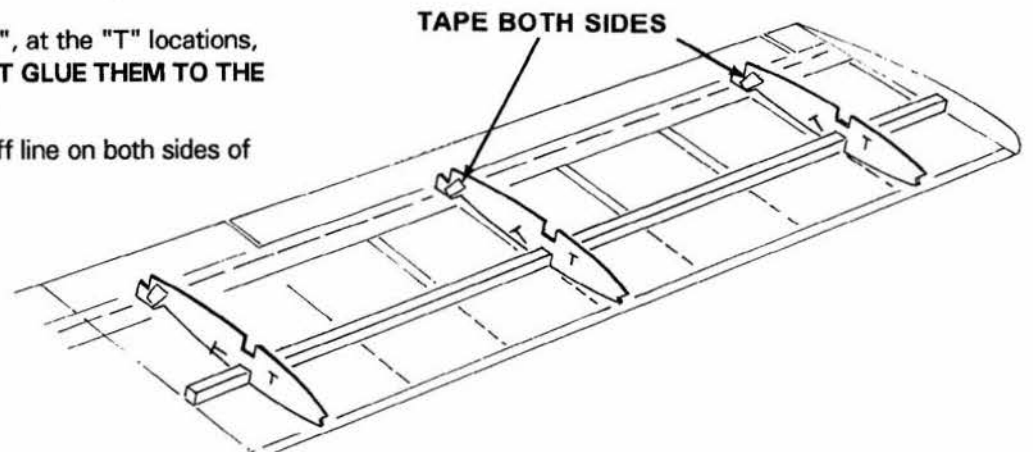

7. Install the notched T.E. onto the tabbed RIBS. Make sure that the trimmed end is flush with the wing centerline.
- Install the remaining wing ribs into the notches and down over the spar. Make sure to align the ribs with the plan. Glue all ribs to the spar and T.E. now.

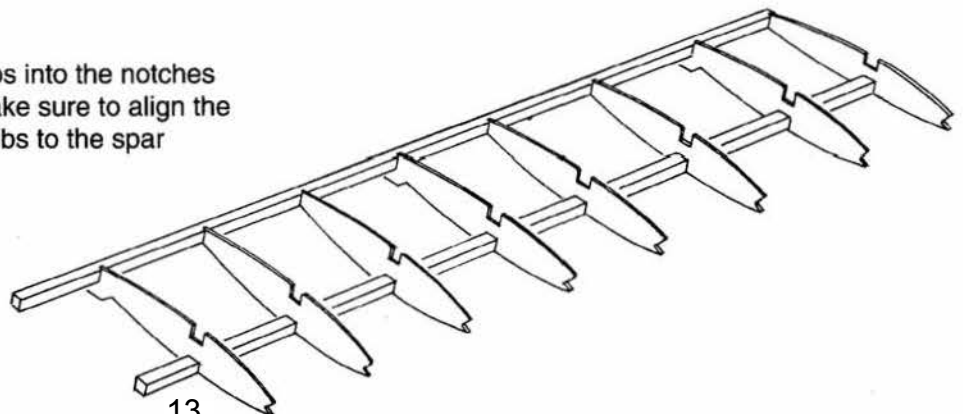

8. Using the **SETBACK GAUGE** as shown, install the top **SPAR** into the notches into each wingrib, and glue the ribs to both spars.

- With the wing-pin notch at the wing centerline, pin and glue the **SHAPED L.E.** into the "V" notch on each wingrib.

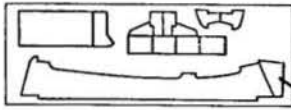

PT. #3580, D/C SHT. 6615

SET-BACK GAUGE

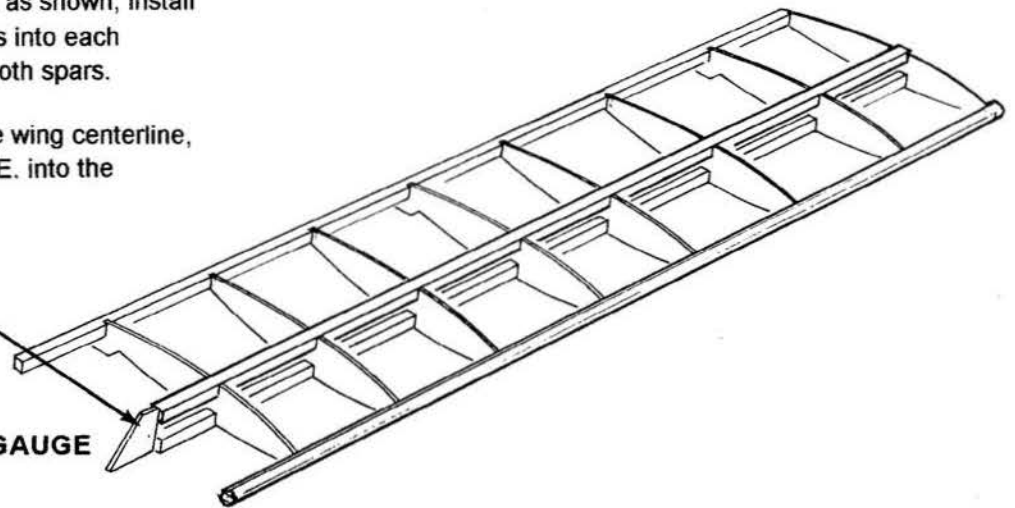

9. Glue and pin the **L.E. SHEETING** to the shoulder on the shaped L.E., rib camber, and the front half of the spar.

- Glue and pin the **T.E. SHEETING** to the notched T. E., flush with the back edge, and to the top of each camber of each rib.

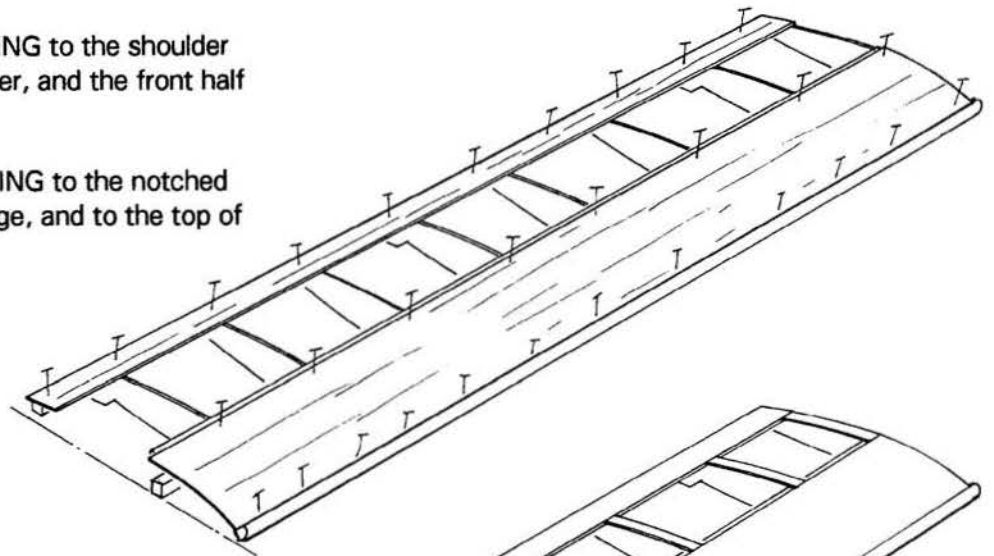

10. Glue the two edge pieces of the **CENTER SHEETING** to the ribs and **WING SHEETING**.

- Install the **CAPSTRIPS**.

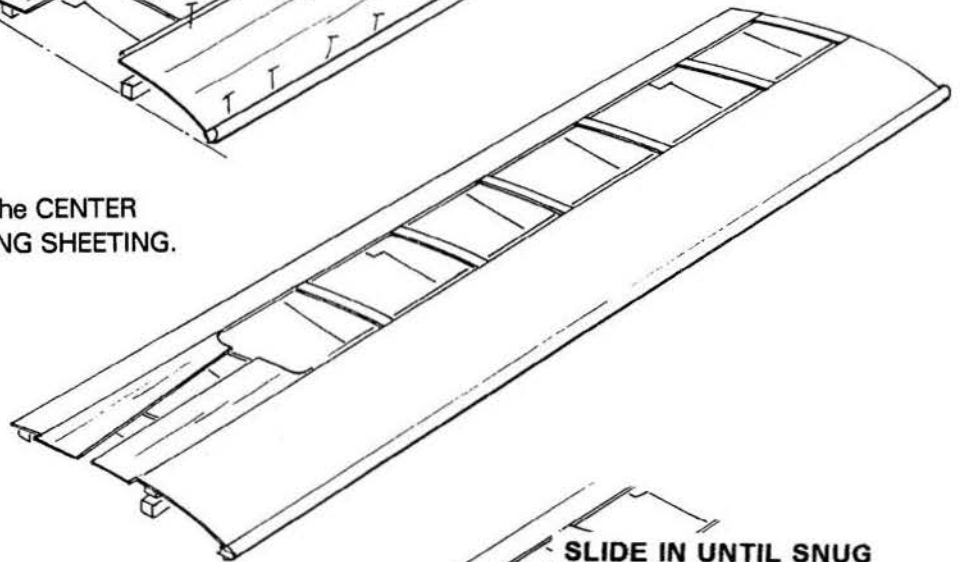

- Preglue and slide the wedge-shaped center piece in place until it fits snugly..

SLIDE IN UNTIL SNUG

TRIM FLUSH

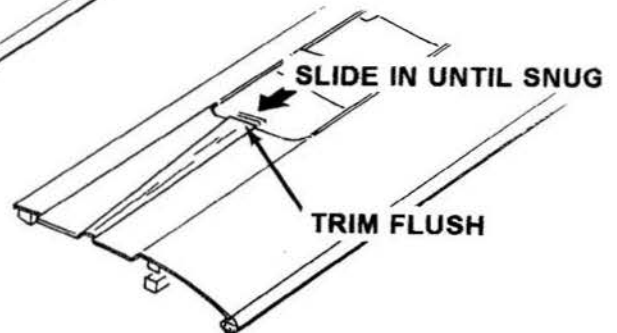

- Trim off the excess in line with the front and back center sheets.

11. Draw a cutline flush with the end of the L.E. to the end of the notched T.E.
- Using an X-acto knife, cut along the line. Use a sanding block, if needed, to achieve a straight edge.
- Remove the wing panel from the plan.

GO BACK TO STEP #3 AND REPEAT THE SEQUENCE FOR THE OTHER WING HALF. WHEN BOTH HALVES ARE COMPLETED, GO ON TO STEP #12.

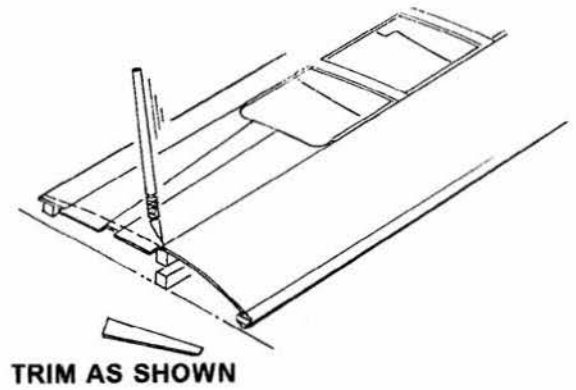

12. Assemble and glue the CENTER and TIP SUPPORTS.
- Position and pin the supports over the plan, as shown.

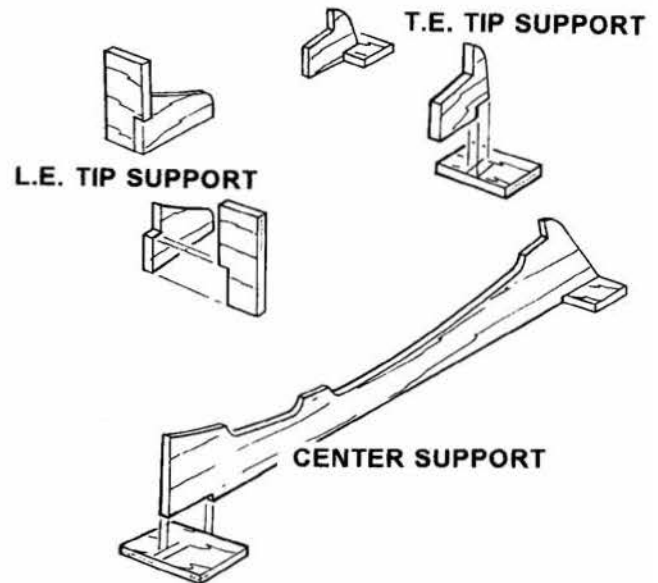

- Position and pin down the supports over the plan, as shown.

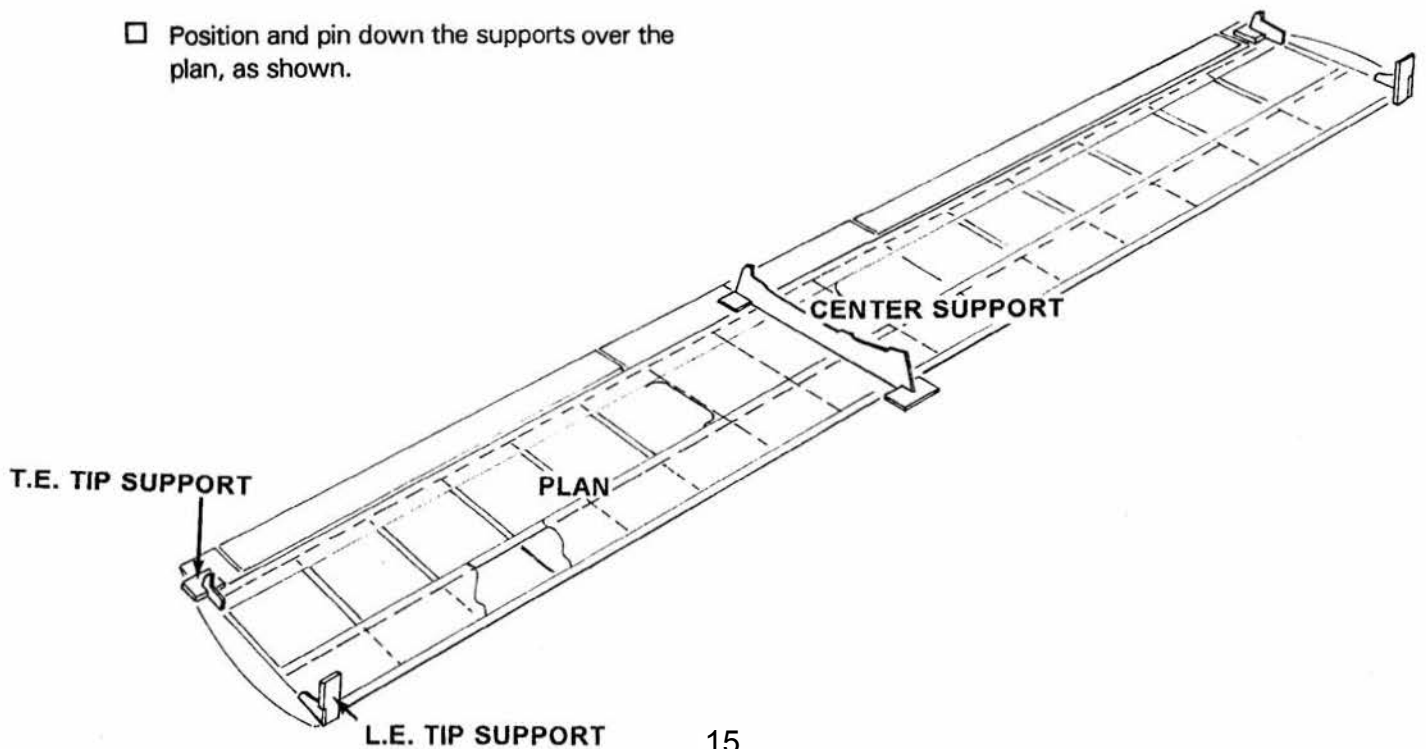

13. With the open framework (wing bottom) facing up, securely mount the wing panels onto the fixtures. Sand the centerline seam to produce accurate fit-up.

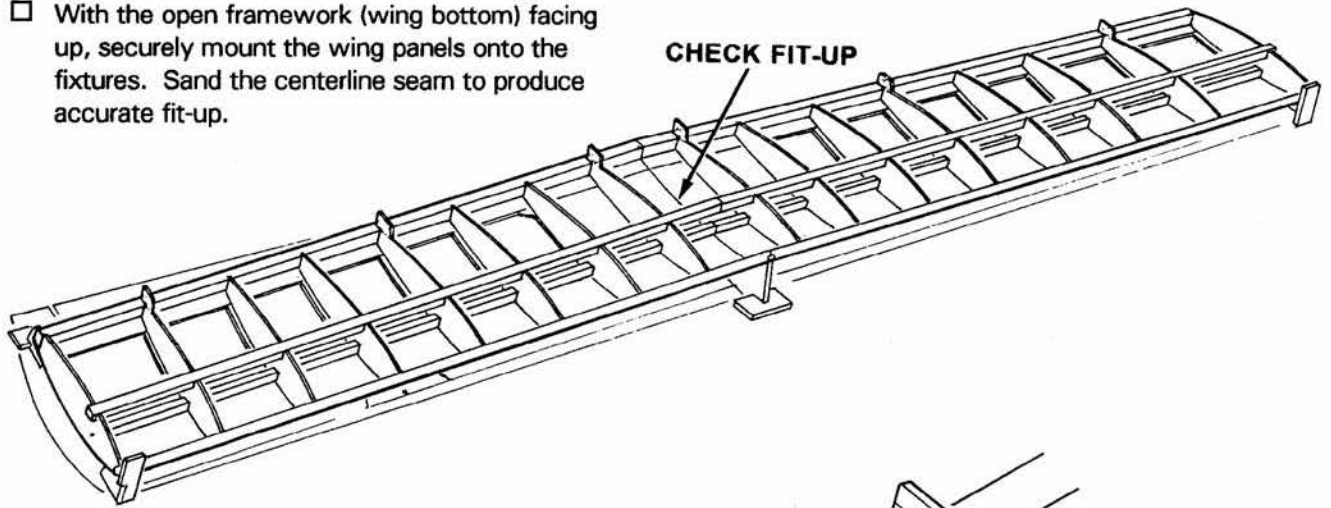

14. Break off all six support tabs along the T.E.

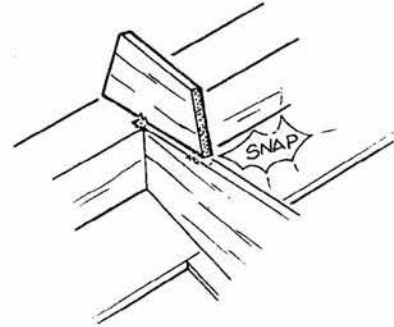

15. Flat sand the gluing surfaces of the DIHEDRAL BRACES and generously glue them to the spars.

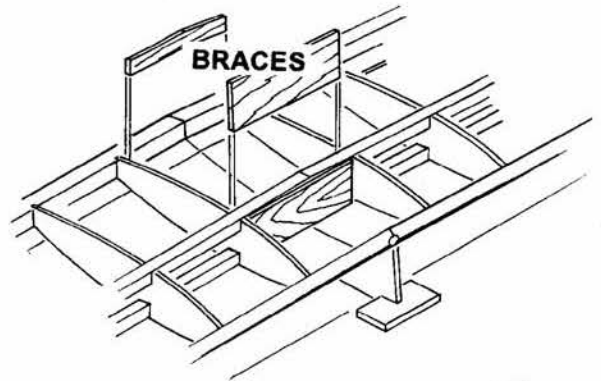

16. Break off the 1/16" balsa SHEAR WEBS from the die sheet and glue onto the spars.

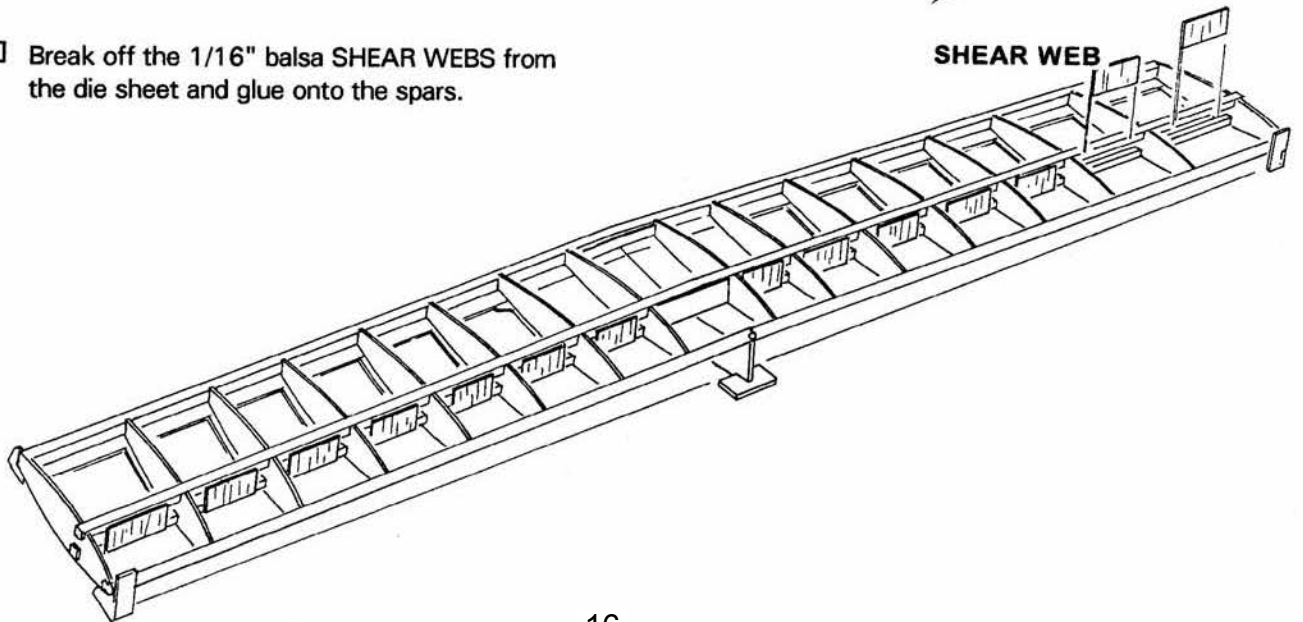

17. Laminate each pair of the CENTER-FRONT RIBS together.

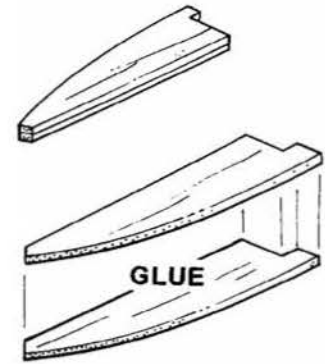

- Drill a 1/4" diameter hole at the center-mark on the lite ply WING PIN DISC.



18. Install a center-front rib assembly.

- Glue the wing disc to the dihedral brace. Be sure that the 1/4" hole is aligned with the center rib.
- Slide the 1/4" WING PIN through the L.E. along the center rib and into the wing disc.
- Install the other center-front rib assembly.

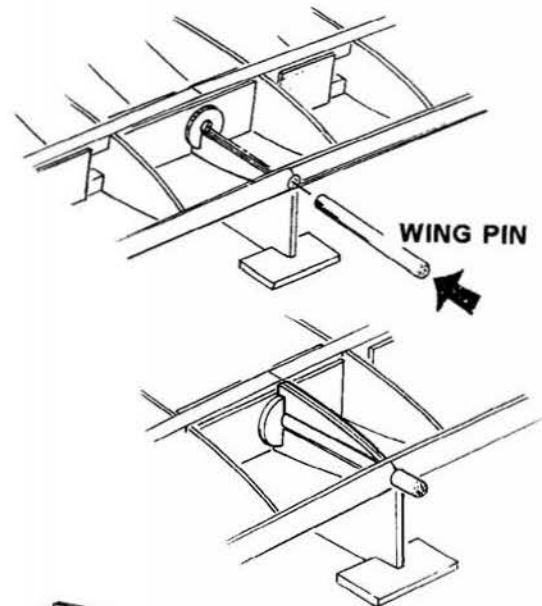

19. Laminate the CENTER-AFT RIB together.

- With the servo cut-out facing **down**, glue into position. Trim to fit, if needed.

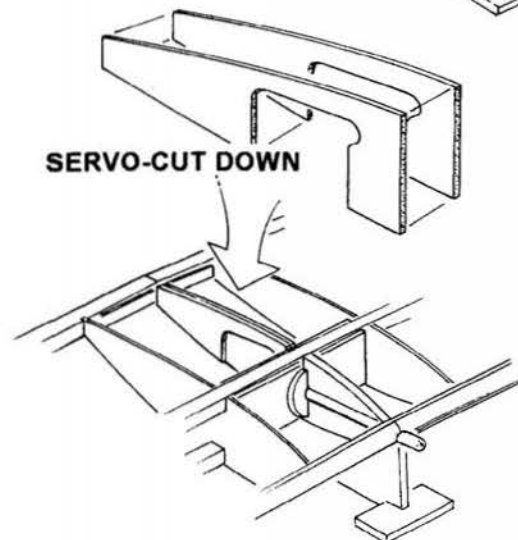

20. Install the L.E. and T.E. sheeting, fitting the center seam as required.

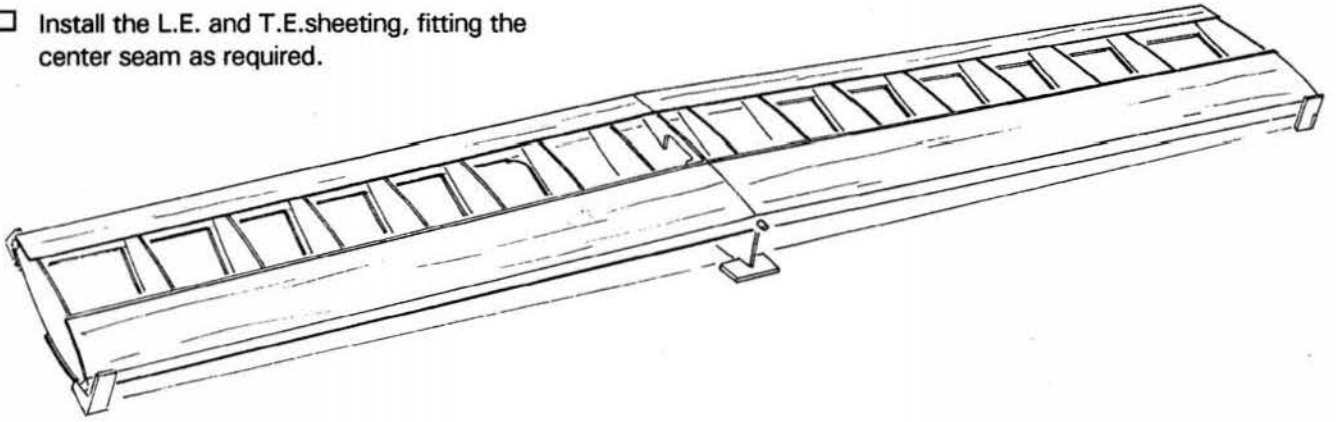

- Install the center sheeting, trimming to fit as you proceed.

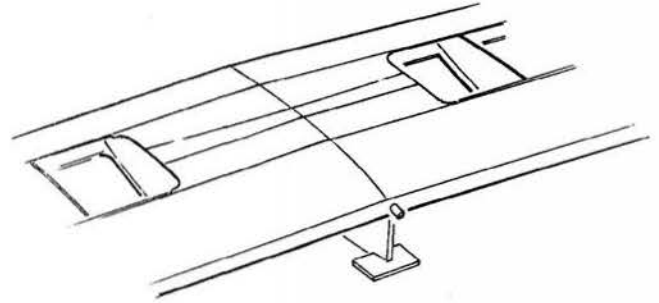

21. Flat sand the gluing surfaces of the RIB DOUBLER and TORQUE SUPPORTS.

- Glue the torque support to the rib doubler. Align the parts as illustrated. Position the parts, as shown, to insure that you make a left and right assembly

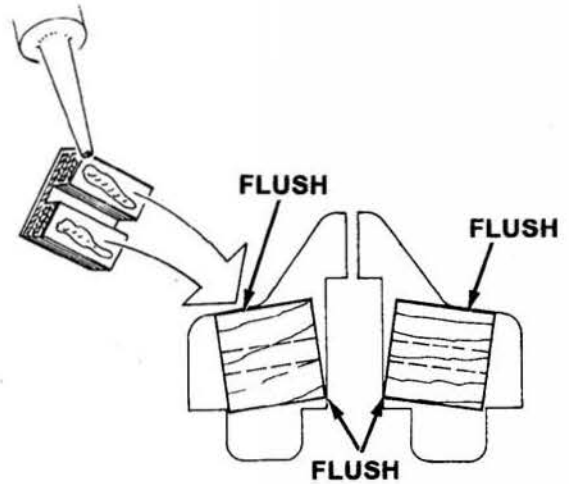

22. Preglue the support assembly and slide it in between the spars to the stops.

- Trim the center sheeting flush with the wing rib.

- Preglue a PLAIN RIB DOUBLER and slide it between the spars, opposite the supports assembly, as shown.

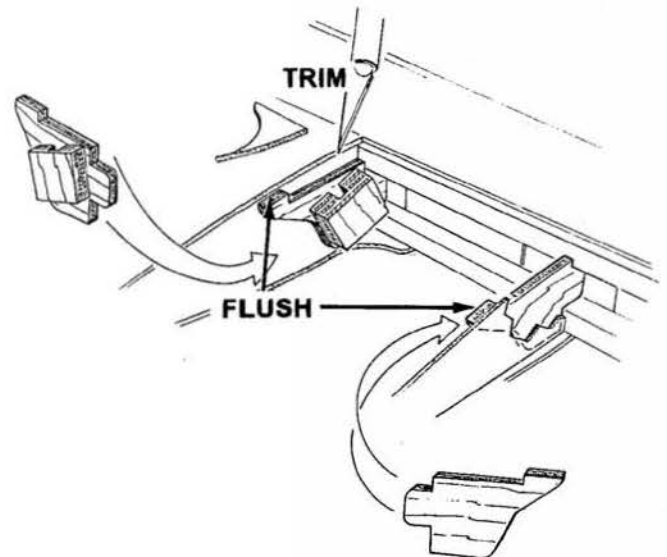

23. With the notch **toward** the center, and the groove facing **out**, generously glue the LANDING SUPPORT into the supports and onto the spar.

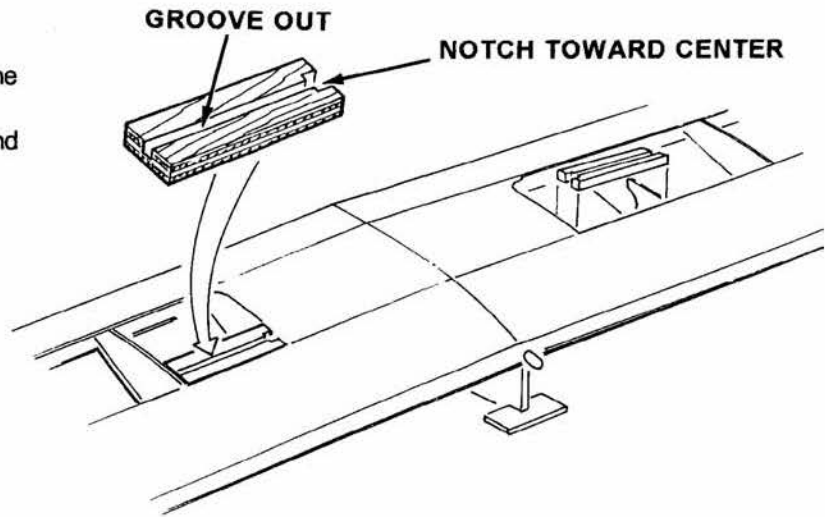

24. Install the CAPSTRIPS on the entire bottom of the wing.
- Using the sanding block with **fine** sandpaper, sand along the T.E. to make flat, as shown.

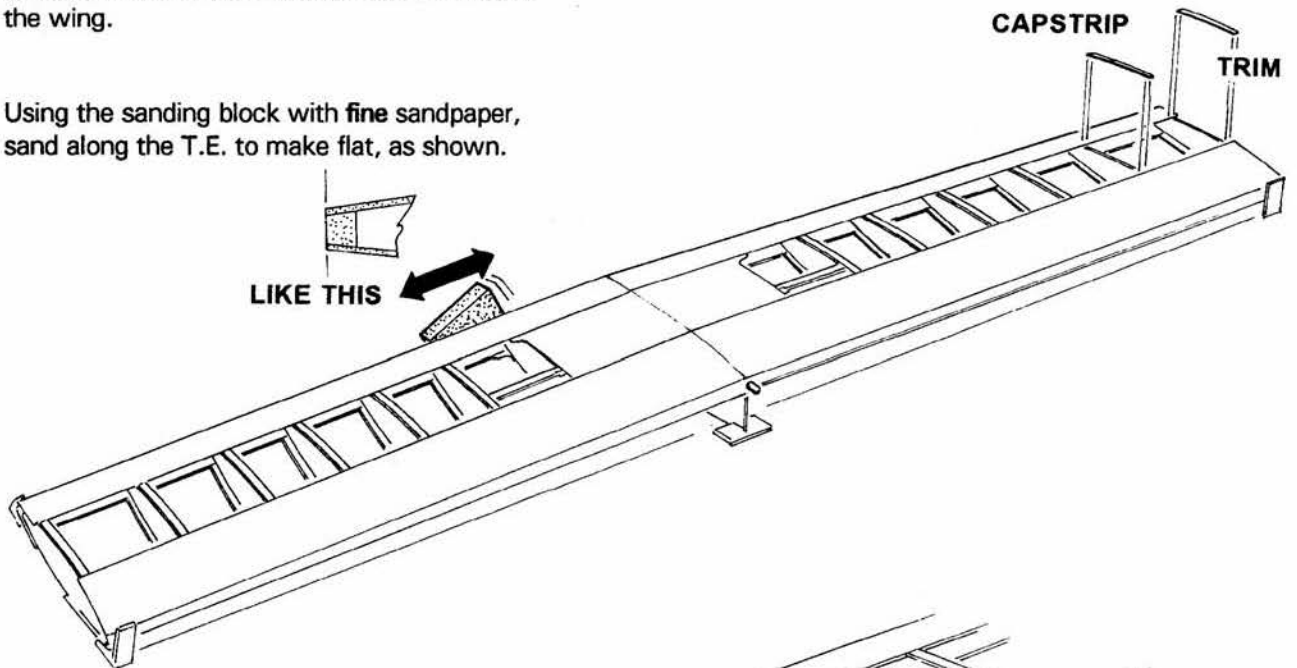

25. Remove the wing from the building board.

- Flat sand the end ribs, as shown.

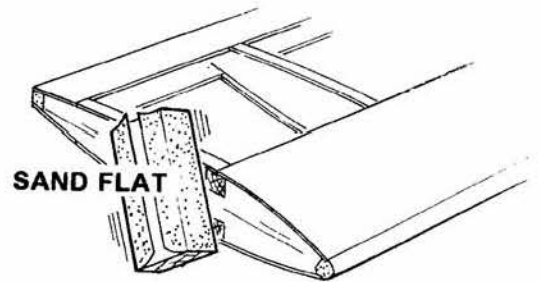

- Mark a centerline on the TRI-STOCK WING TIP.
- Glue the tip to the end rib, locating the centerline on the mid-point of the L.E. and T.E.
- Glue the OUTBOARD T.E. to the tip and T.E.

1/2 THE WIDTH

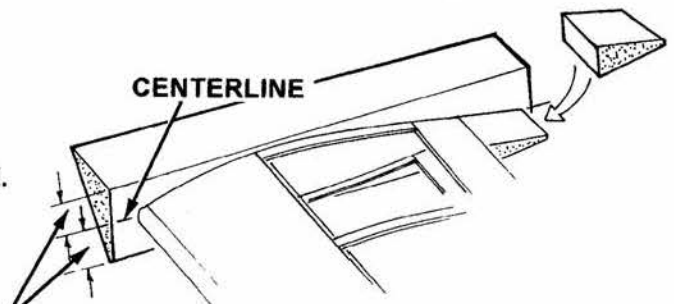

26. Rough carve the tips to shape. Sand to the final shape, using **medium**, and then **fine**, sandpaper.

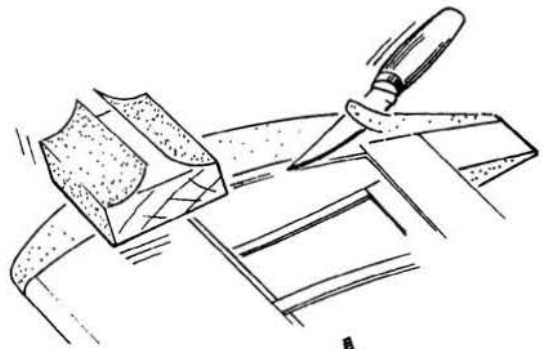

27. Slide the ROD SUPPORT onto the TORQUE ROD. Trim the BRASS BEARING TUBE to 4-1/4" and slide it onto the TORQUE ROD.
- With the threaded end 90 degrees vertical, bend the plane end 1/2" x 90 degrees horizontal. Be sure to bend a left and a right torque rod.

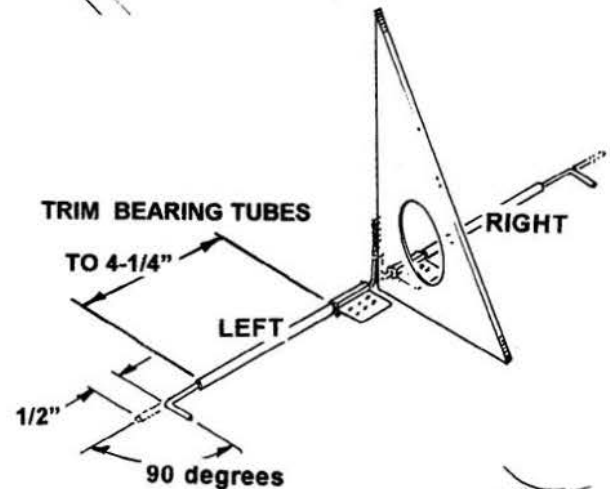

28. Measure 5/8" from both sides of the wing centerline on the top. Use the threaded end of the torque rod to file out a clearance slot on both the wing and the inboard center section.

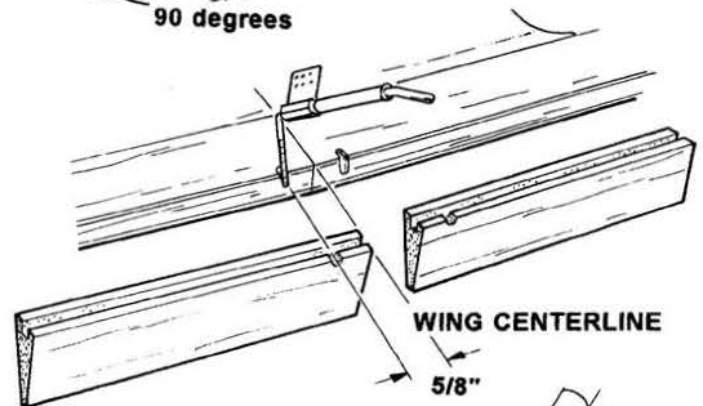

29. Cut a slot and trim clearance into the T.E. center section, to allow the ROD SUPPORT to fit. Glue the ROD SUPPORT and BRASS BEARING TUBE in place into the T.E. center section.

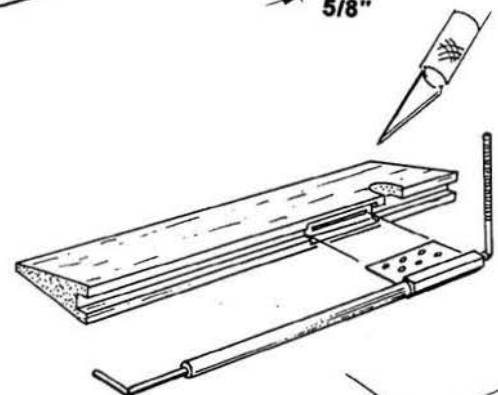

WARNING: BE CAREFUL NOT TO GLUE THE TORQUE ROD TO THE BEARING TUBE.

- Glue the center section assembly to the wing with the threaded end to the top side of the wing.

WARNING: BE CAREFUL NOT TO GLUE THE TORQUE ROD TO THE WOOD STRUCTURE OR THE BEARING TUBE.

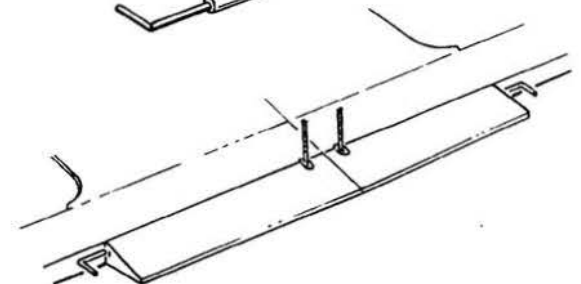

30. Check that the AILERON has at least 1/16" clearance on each edge. Trim, if needed.
- Mark the location of the torque rod bend.
- Transfer the hinge locations onto the wing and aileron, and scribe the centerline.
- Drill a 3/32" diameter hole, 5/8" deep, at the torque rod location in the ailerons.
- Cut a slot for hinges at the marked location.

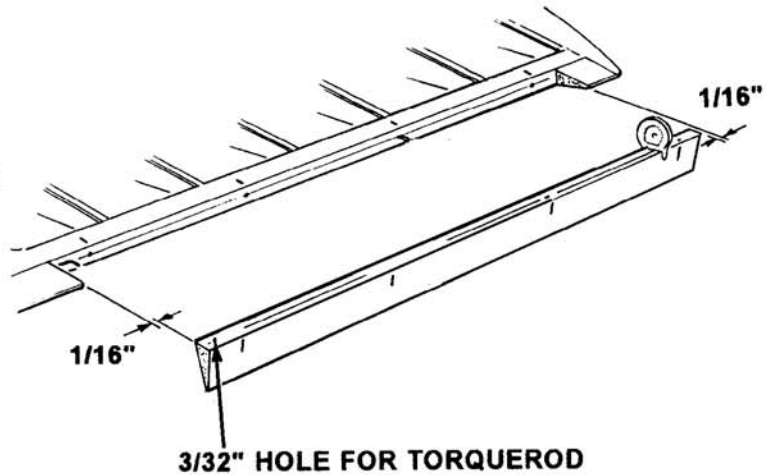

31. Bevel both sides of the ailerons.

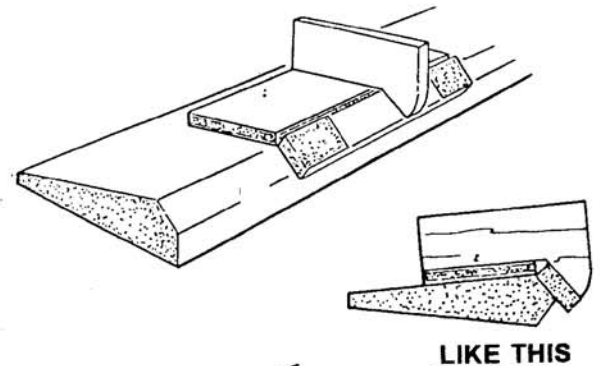

- Carefully cut out the torque rod clearance slot. test-fit until it fits properly.

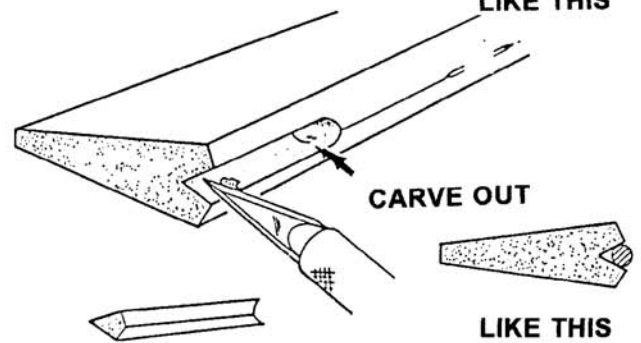

32. Finish sand the entire wing.
- Wrap the center of the wing, using 3/4" NYLON FABRIC.
- Use a small plastic bag over your finger to smooth the glue over the nylon tape.

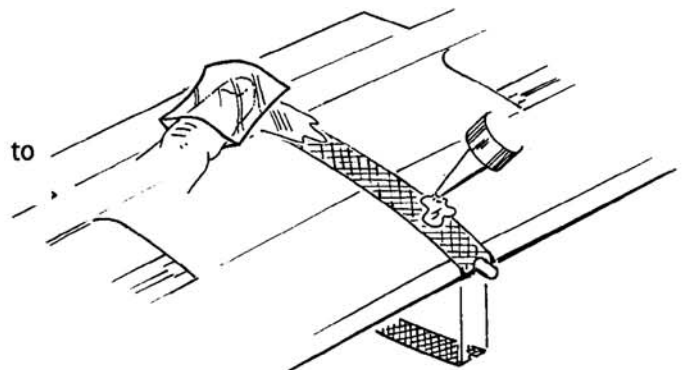

CONSTRUCTING THE FUSELAGE (25 Steps)

1. Collect all the parts that you will need to construct the FUSELAGE.

THEY INCLUDE:

- | | | |
|---|------------------|--------------------------|
| (2) FUSELAGE SIDE | (.110 LITE PLY) | PT. #3570, D/C SHT. 6601 |
| (1) FUSE. TOP AFT, STAB PLATFORM | (LITE PLY) | PT. #3571, D/C SHT. 6602 |
| (1) FUSE. BOTTOM AFT, FUSE. DOUBLERS | (L-PLY) | PT. #3572, D/C SHT. 6603 |
| (1) FUSE. BOTTOM FRONT & FORMERS "C" & "D" | (LITE PLY) | PT. #3573, D/C SHT. 6604 |
| (1) CANOPY PLATFORM & INSTRUMENT PANEL | (LITE PLY) | PT. #3574, D/C SHT. 6605 |
| (1) FUSELAGE TOP FRONT, HATCH, & FORMER "A" & "B" | (LITE PLY) | PT. #3575, D/C SHT. 6606 |
| (1) FIREWALL & WING PIN DISK | (BIRCH PLY) | PT. #3576, D/C SHT. 6607 |
| (2) HATCH RAILS | (SHAPED BASS) | PT. #4895 |
| (2) WING MOUNTING BLOCK | (1/4" BIRCH PLY) | PT. #4896 |
| (2) ENGINE MOUNTS | | PT. #1466 |
| (1) NYLON STEERING BEARING | | PT. #1413 |
| (8) 4-40 BLIND MOUNTING NUTS | | PT. #1125 |
| (8) #4 FLAT WASHERS | | PT. #1139 |
| (4) 4-40 x 3/4" BOLT | | PT. #1007 |
| (4) 4-40 x 1/2" BOLT | | PT. #1006 |
| (2) 6-32 BLIND MOUNTING NUT | | PT. #1124 |
| (2) #6 x 3/4" FLAT WASHER | | PT. #1144 |
| (2) #6 FLAT WASHER | | PT. #1140 |
| (2) 6-32 x 1" BOLT | | PT. #1023 |
| (4) 1/8" O.D. x 24" NYLON TUBE | | PT. #5614 |
| (1) CONNECTOR BODY | | PT. #1375 |
| (1) NYLON SNAP-NUT | | PT. #1461 |
| (2) #2 x 5/16" SHEET METAL SCREW | | PT. #1086 |

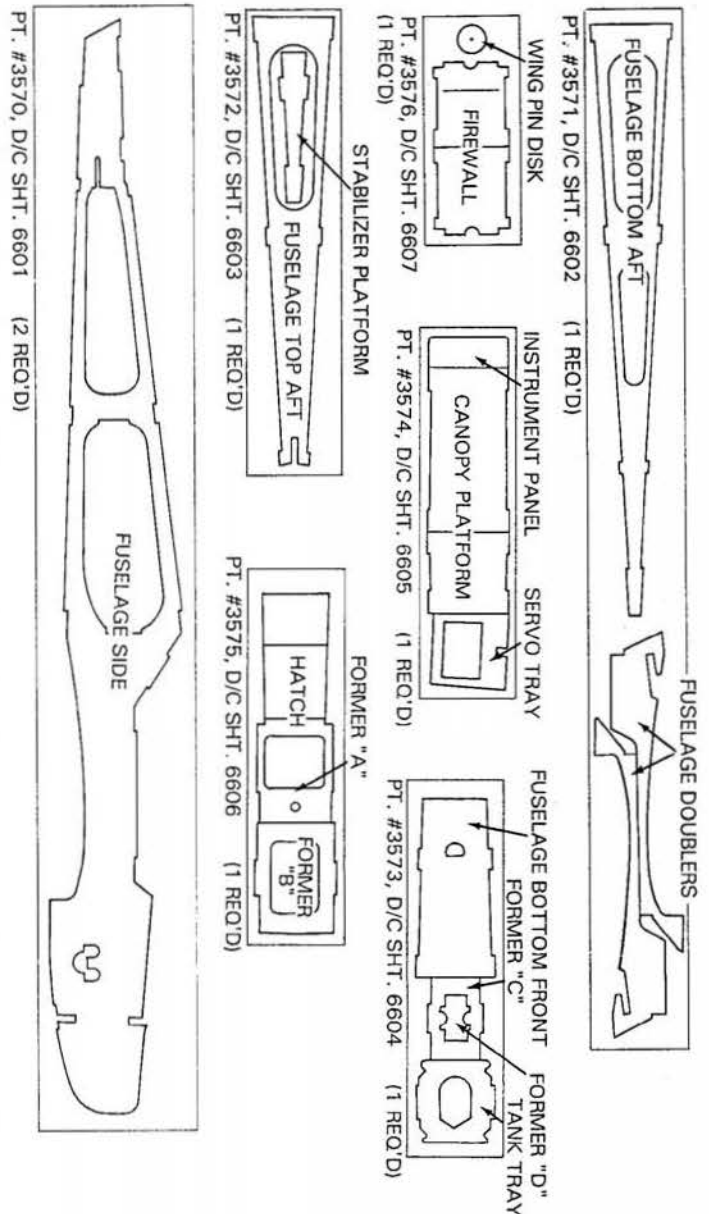

2. SUPER JET glue the two 1/8" ply FIREWALL parts together. Keep the center points and centerline facing out. Make sure that all of the edges are in line. Tape them together and place them under a weight until they are dry.

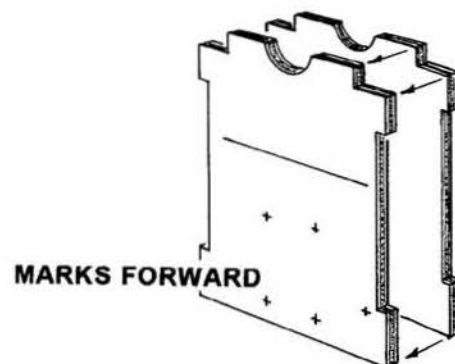

3. Tack-glue the motor that you intend to use to the **MOTOR MOUNTS**. Do not position the engine tight between the two mounts. Leave a 1/16" gap on each side to allow engine side thrust adjustment. Center the assembly on the firewall and align the mark on the mount to the centerline on the firewall.

- Mark the hole locations onto the **FIREWALL**.

ALIGN THE MARKS

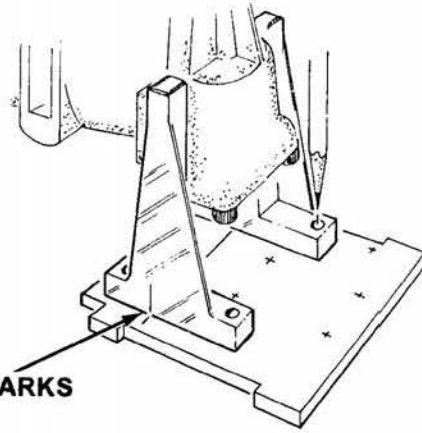

4. Drill 1/8" diameter holes at the 4 motor mount locations, the 4 centermarks for the **STEERING BEARING**, and the centermark for the steering arm.

 - Insert the eight 4-40 **BLIND NUTS** on the back side of the firewall, in the motor mount and steering bearing holes. Seat them into the firewall, using a few soft blows with a hammer.
 - Generously coat the edges of each nut with **JET glue**.

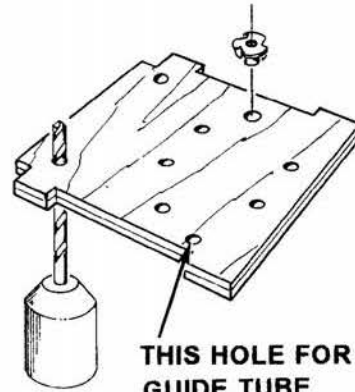

THIS HOLE FOR STEERING GUIDE TUBE

5. Bolt the **STEERING BEARING** to the firewall using four 4-40 x 1/2" **BOLTS** with **WASHERS**. Note that the short bearing is to the bottom.

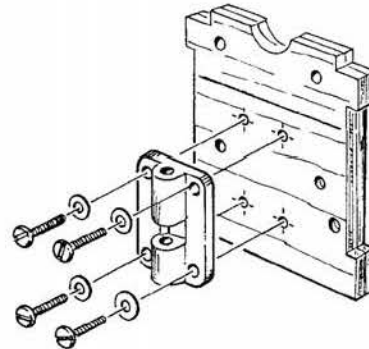

6. Lay the **FUSELAGE SIDES** on a flat surface, side-by-side, so they are mirror images. This will insure that you build a left and right fuselage side.

 - Glue a **FUSELAGE DOUBLER** to each side, aligning the front and rear corners for proper positioning.

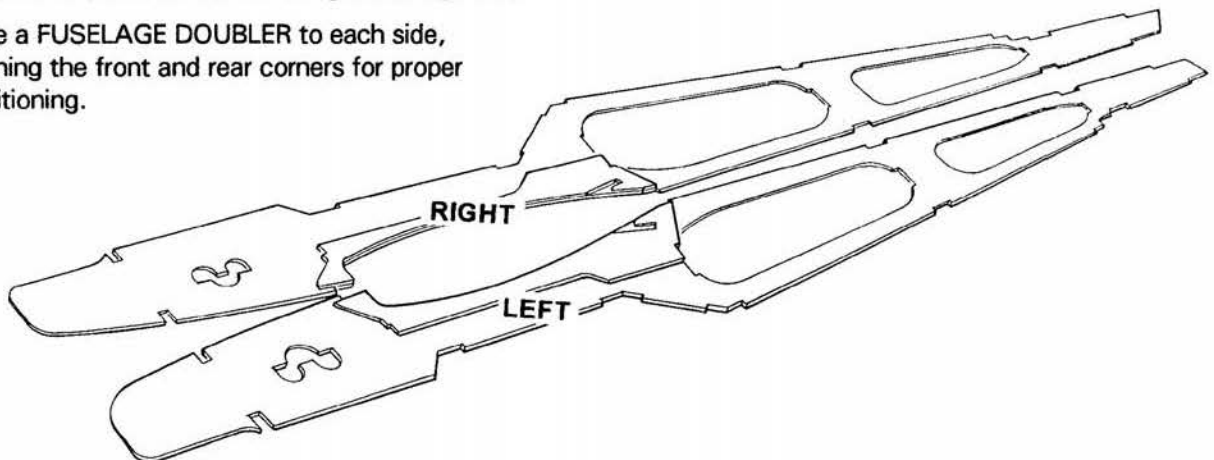

7. Use rubber bands to hold the parts together. Assemble the fuselage sides, firewall (steering bearing forward), and all of the formers. Place a 1/4" balsa scrap at the tail. **Do not glue anything yet!**

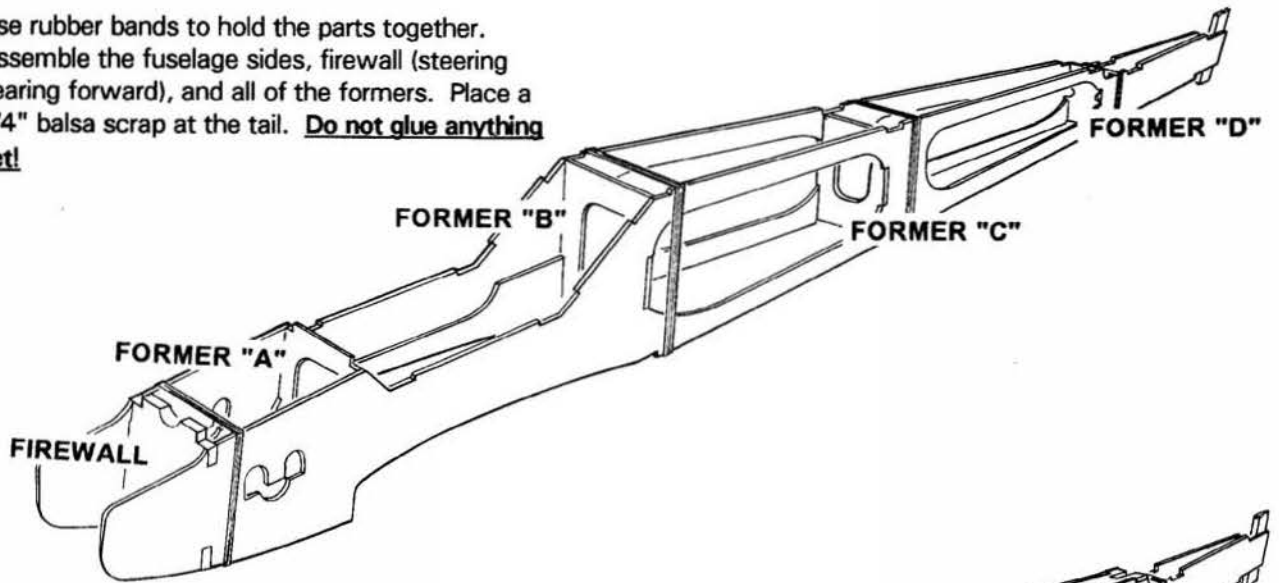

8. Glue the two RAILS to the sides.
- Slide the FUSELAGE TOP AFT under the rubberbands and into the notches, but **do not glue!**

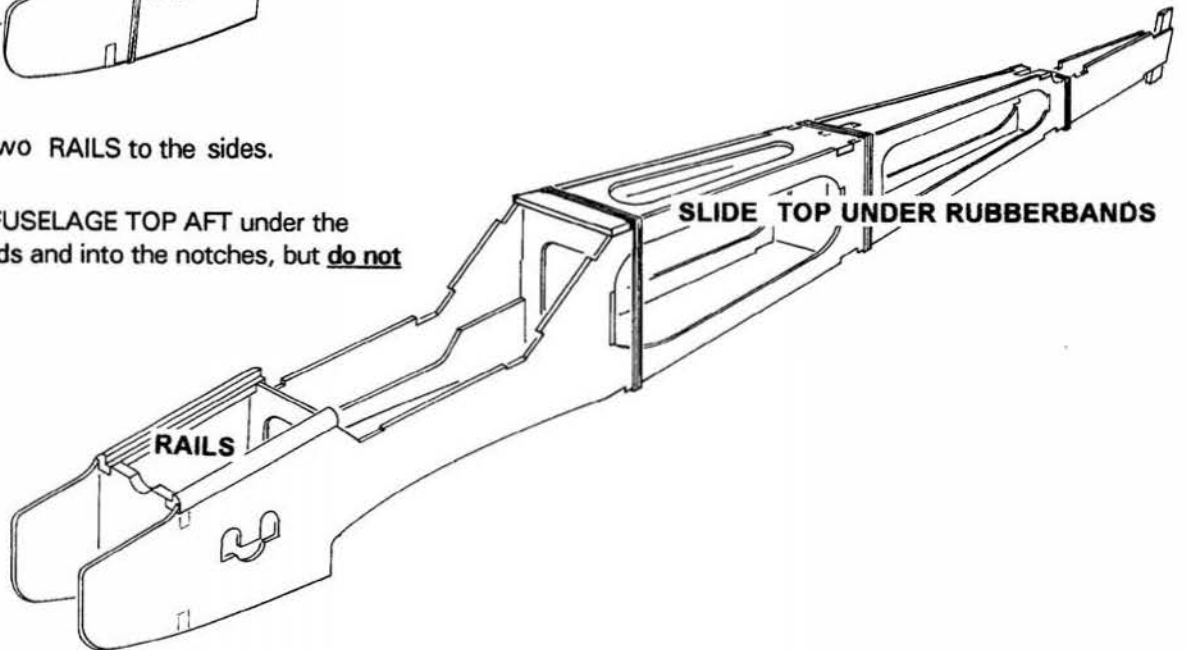

9. Flip the fuselage over and slide the FUSELAGE BOTTOM FRONT and AFT under the rubber bands, but **do not glue.** It may be necessary to add a few more rubber bands to the front to pull up the bottom sheet.

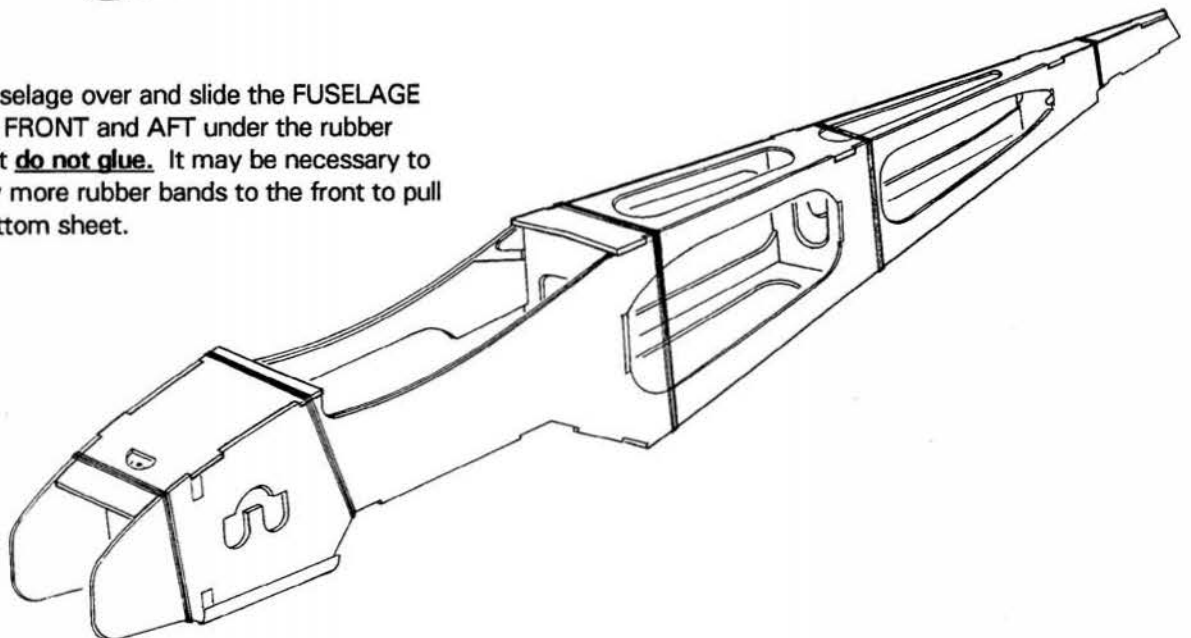

10. Stack the two 1/4" ply WING MOUNTING BLOCKS together.
- At the location shown, drill a 5/32" hole through both parts.
- Insert a 6-32 blind nut into each hole. Tap the flange with a hammer to seat the spurs into the wood.

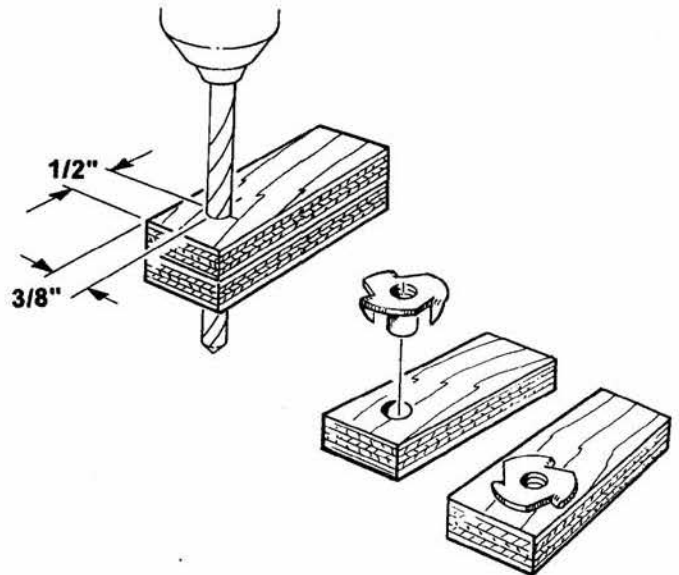

11. With the blind nut flanges to the inside, securely glue the wing mounting blocks in place.

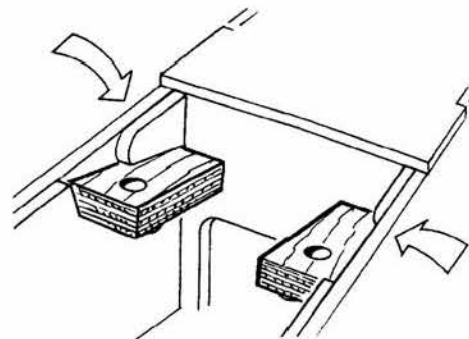

12. Position the fuselage directly over the plan. Use a triangle to check the alignment. When you are satisfied with the alignment, glue all the joints and seams by reaching in through the openings.

- Double check the entire fuselage to make sure all the seams are securely glued.

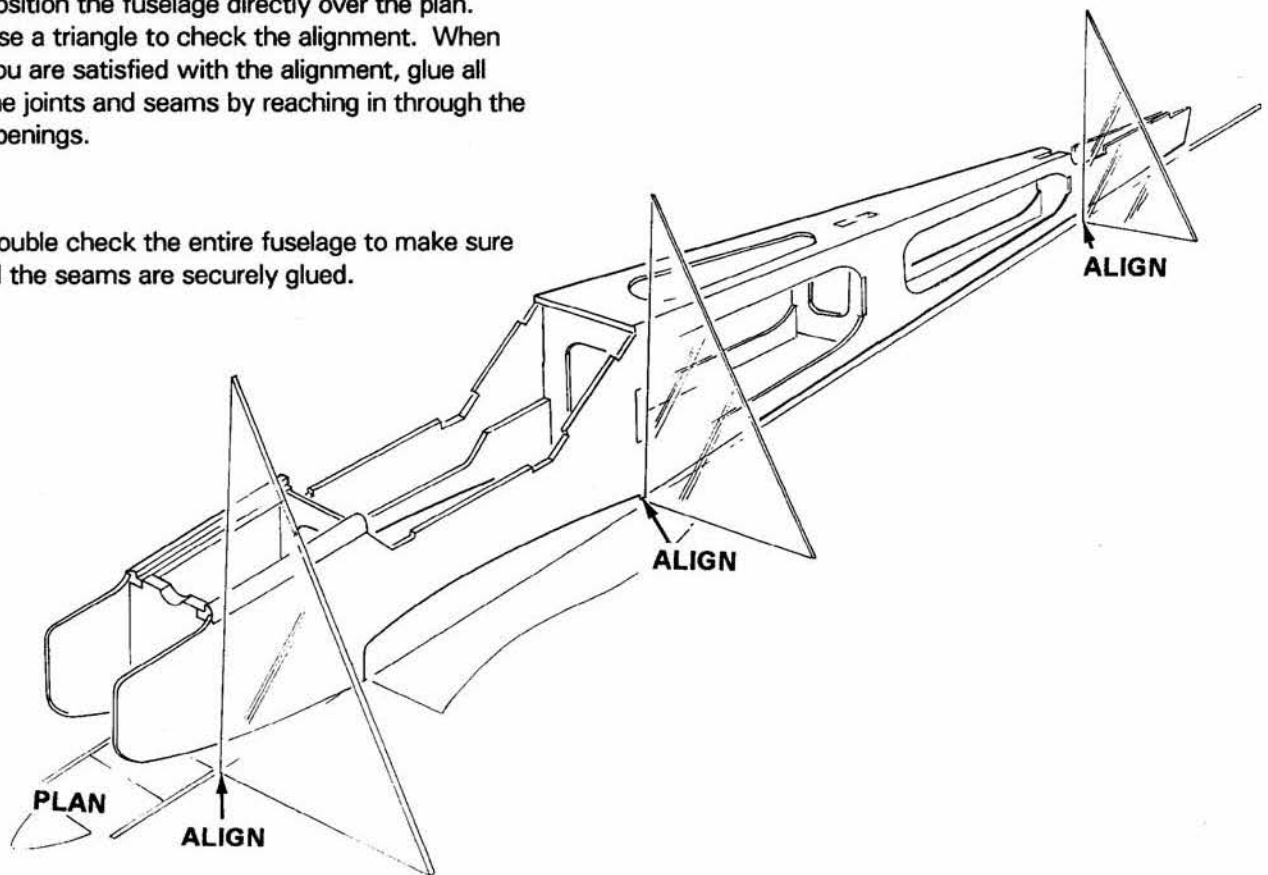

13. Install the STAB PLATFORM. Check the alignment and glue in place.

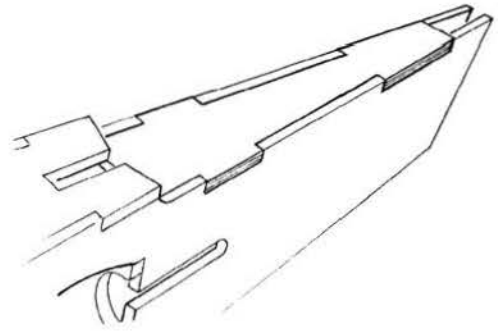

14. Drill a 1/4" hole at the centermark in the WING PIN DISK.



15. Get the wing, which will be needed for this step.

- Place the fuselage onto the wing, with the wingpin through the former.

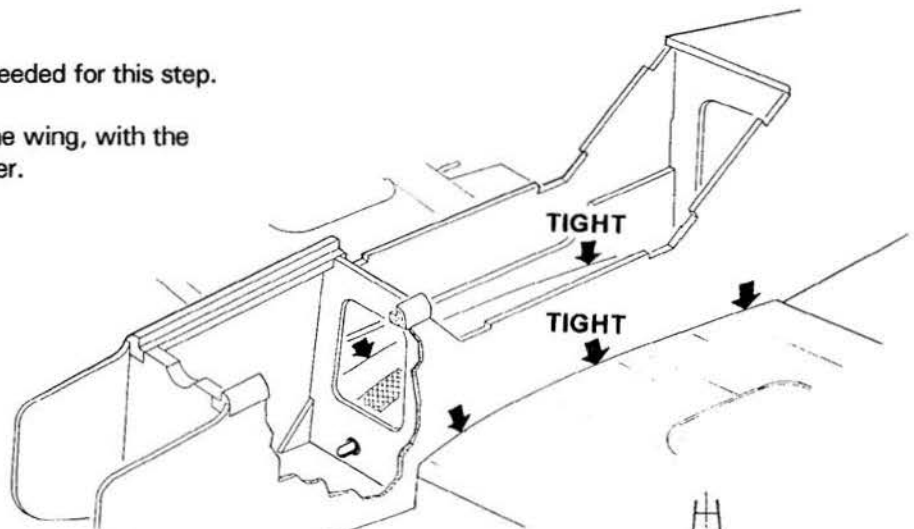

- With the wing fitting the saddle tightly, adjust until the two diagonal dimensions are equal. Mark the position and tape in place.

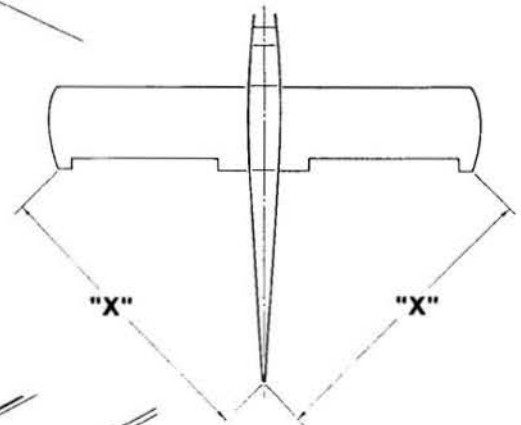

- Glue the disk doubler to former "A". Make sure the wing remains tight against the wing saddle.

WARNING: DO NOT GLUE THE WING PIN TO THE DISK.

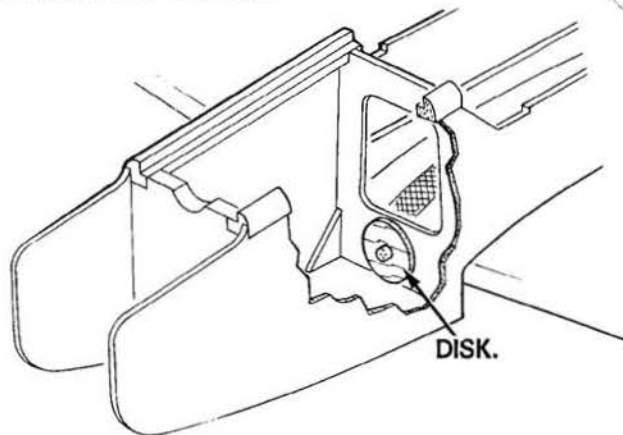

16. Use a long drill bit, no larger than 7/64" diameter, to drill a pilot hole through the wing. Use the blind nuts as locators.

Note: The aileron pushrod works great as a drill bit, if you chisel cut the plain end.

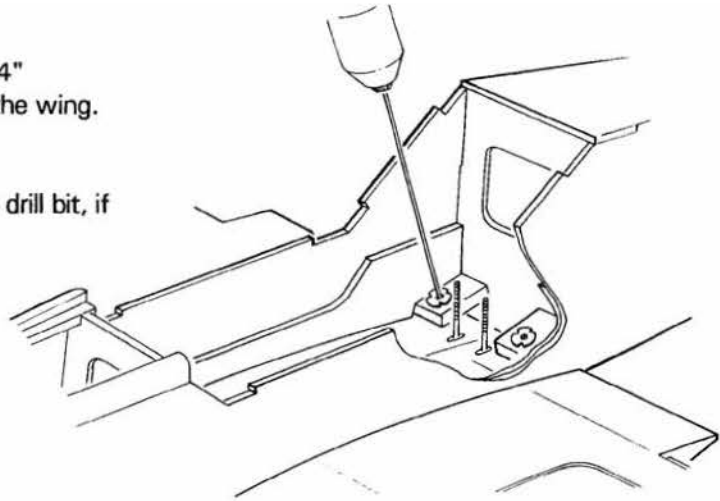

- Remove the wing from the fuselage and drill a 5/32" hole through the wing, using the pilot hole as a guide. Test bolt the wing to the fuselage and check the diagonal dimensions again.

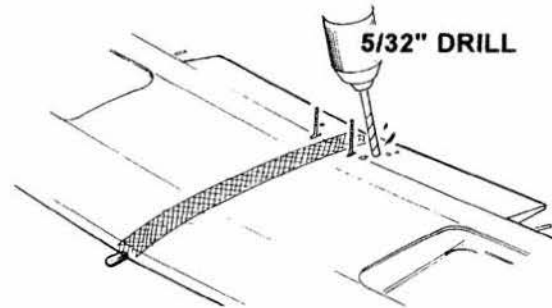

5/32" THRU TAPE

17. Remove the wing and glue a strip of nylon fabric over the bolt holes. Drill through the tape when dry.

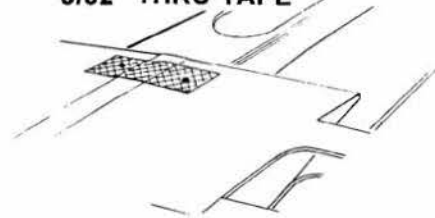

CORNICE PARTS

18. With the wing square and firmly bolted in place, build the gussett onto the wing.
 Install the front piece above the L.E., then glue the sides to the wing. Use the top to gauge the side position.
 Install the top and lightly sand to blend to the fuselage.
 Feather the transition with balsa MODEL MAGIC. You may want to fill this in 3-4 applications, sanding between each.

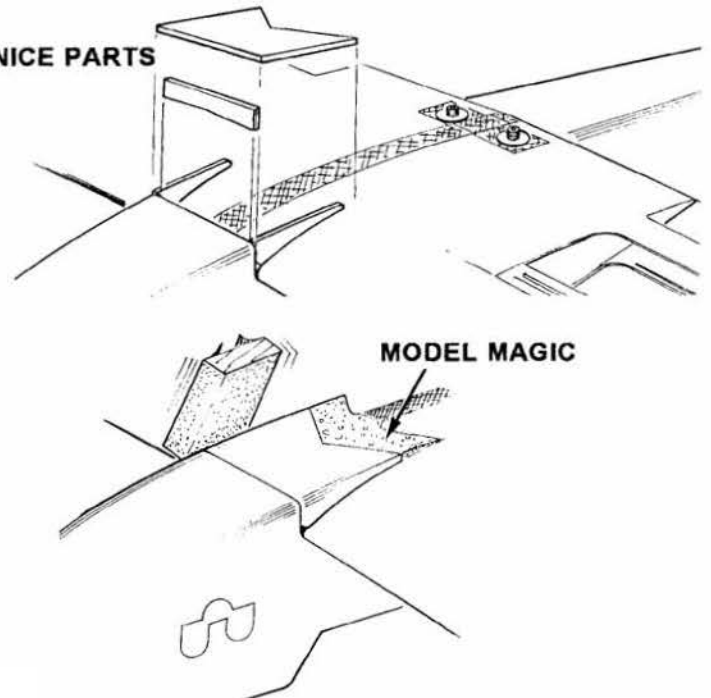

19. Sand the shaped rails in line with the instrument panel angle.

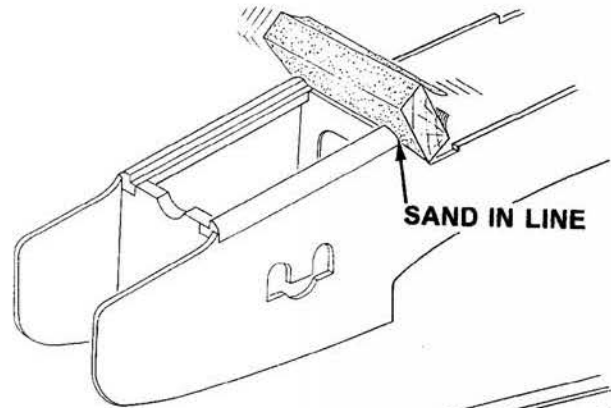

20. Install the CANOPY PLATFORM and the INSTRUMENT PANEL.

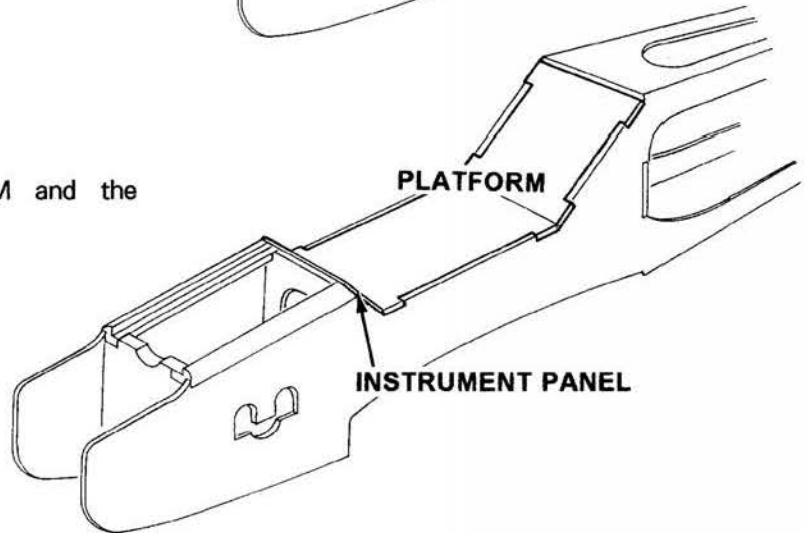

21. Install the FUSELAGE TOP FRONT onto the rail shoulder and against the instrument panel.

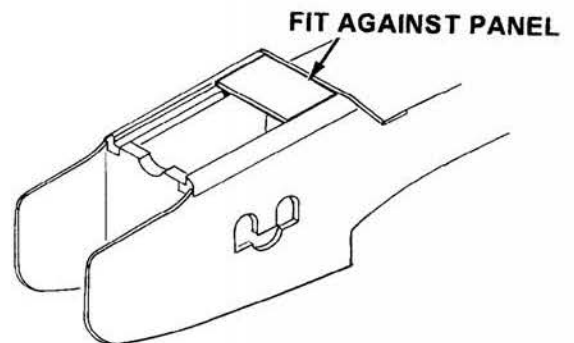

22. Sand the entire fuselage, first using medium grit and then switching to fine. Remember that covering will not hide a rough surface.
 Coat the firewall with JET GLUE. Be careful not to let glue get into the threaded blind nuts.

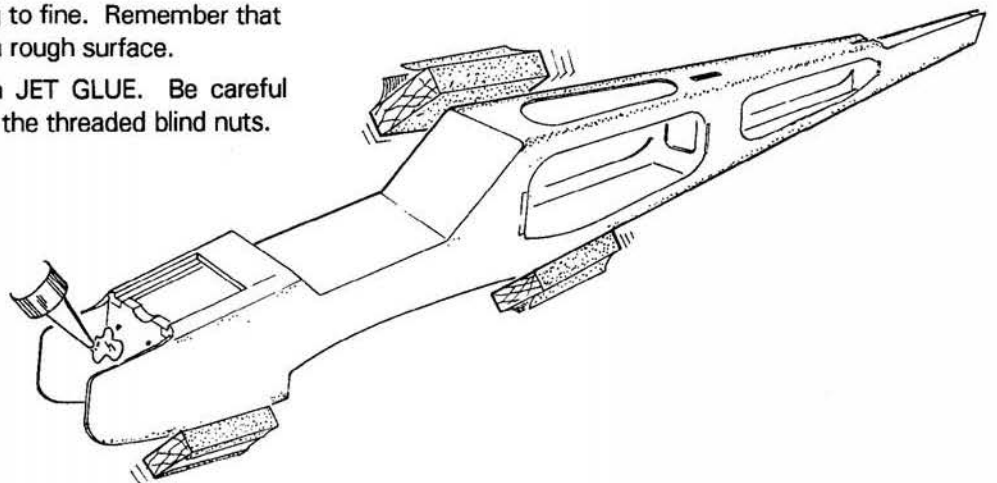

23. Slide a 1/8" NYLON PUSHROD GUIDE into each exit slot at the tail of the fuselage. One is for the elevator and the other is for the rudder.

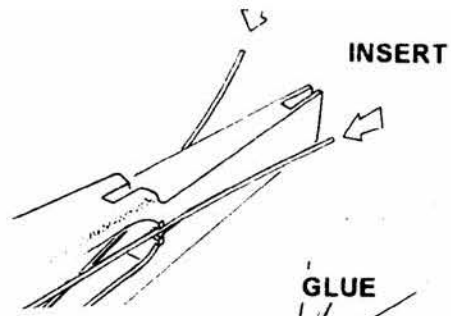

- Apply glue to the tube at the exit and **securely** fix the tube to the fuselage.

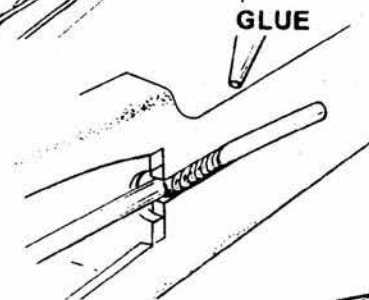

- Trim or sand the tubes flush with the sides.

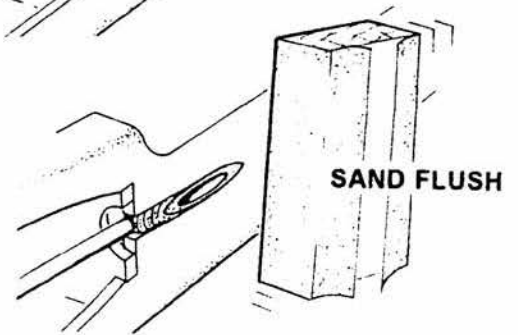

24. Install the motor mounts and position the engine.
- Install a CONNECTOR BODY to the throttle arm and secure it with a NYLON SNAP NUT.
- Mark the location of the throttle pushrod exit.
- Drill a 1/8" hole and insert a nylon guide tube.
- Install the remaining tube in the hole for the steering arm at this time.
- Rough-cut both tubes to length now. Finish-cut when you install the radio.

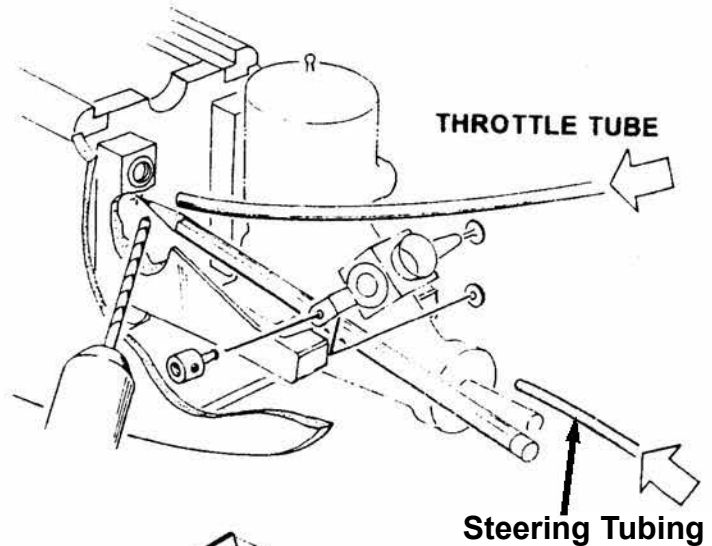

25. Glue a scrap piece of lite ply to the bottom-aft side of the hatch.
- Drill a 3/32" hole at the two centermarks. Test-fit the hatch onto the rail and temporarily secure the two #2 x 5/16" screws.

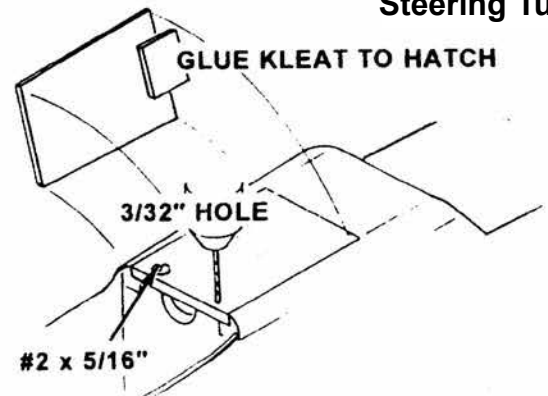

THIS COMPLETES THE BUILDING PORTION OF YOUR TIGER 2.

NOW GO TO THE "COVERING" SECTION IN THE GENERAL INFORMATION BOOK. AFTER THE MODEL IS COVERED, RETURN TO THE "FINISHING THE MODEL" SECTION IN THIS BOOLET AND CONTINUE.

FINISHING THE MODEL

1. Permanently attach the elevator to the stab and the rudder to the fin, using epoxy to glue the hinges.
2. Remove a portion of the covering to provide a wood-to-wood bond and glue the stab to the platform. Make sure that the stab is properly aligned in both the top and rear views.

WARNING: BE VERY CAREFUL NOT TO CUT INTO THE WOOD STRUCTURE WHILE TRIMMING THE COVERING.

3. When the stab is dry, glue the fin into place. Check the fit-up at all contact points and make sure that the elevator connecting wire has enough clearance from the inside of the rudderpost. Check the rear view for proper alignment.

4. Assemble the steering arm and slide the gear strut into the bearing. After you have determined the correct position, slide the strut out and file a flat in the strut for the set-screw to seat. Reassemble and secure.

5. Mount the engine with the proper right thrust. See the plan for the correct orientation. Drill a $3/32$ " pilot hole for each #6 x $3/4$ " mounting screw.

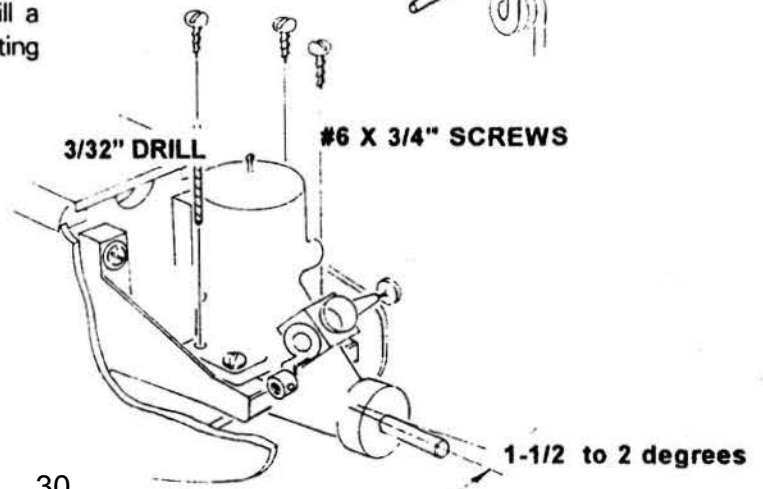
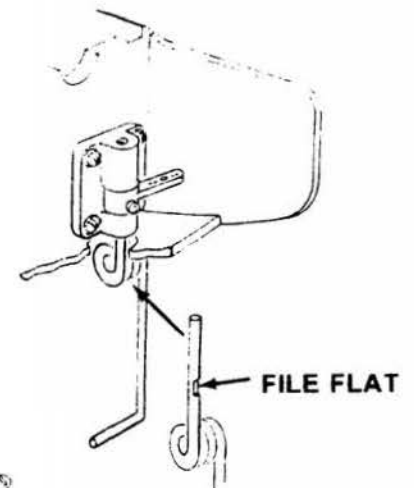
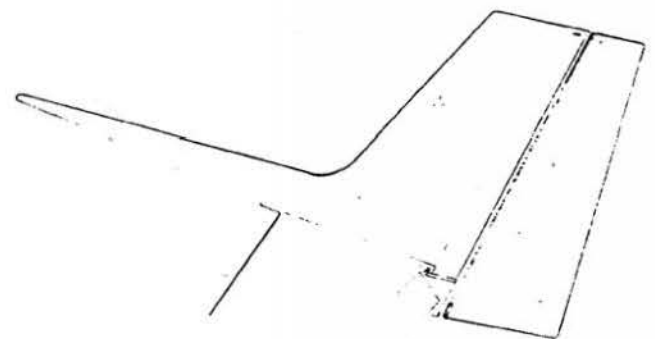
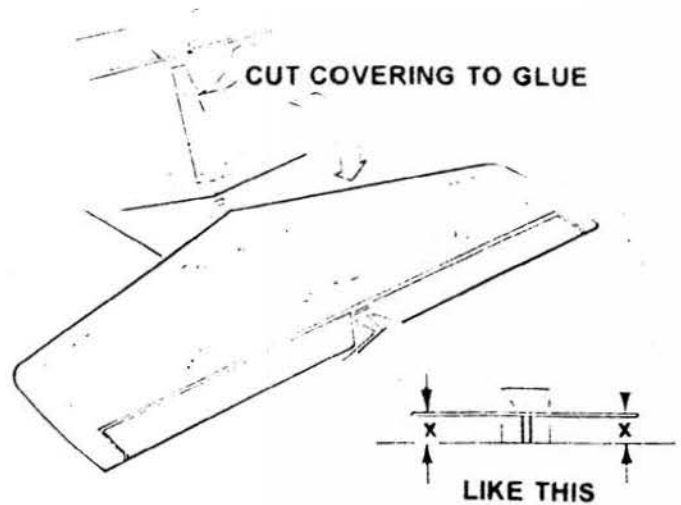

6. Apply the instrument panel decal.
- Trim the canopy to overlap the fuselage side by 1/8" and EPOXY glue and tape in place until dry.. Be very careful and do not use too much glue for this application.

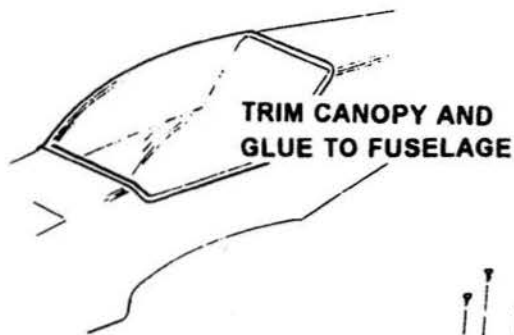

7. Now, let's finish the wing.

- Install the main landing gear wire down into the slot. Use two nylon straps and four #2 x 5/16" screws per side to secure the wire gear. You will need to supply one 2-1/4" diameter wheel and two 5/32" wheel collars per axle.

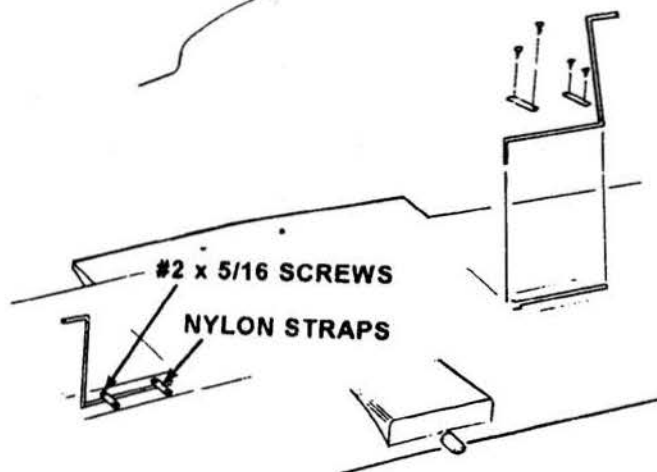

8. Cut an opening for the aileron servo and glue the lite-ply servo mounts in place. Mount the servo.
- Permanently install the ailerons to the wing, using epoxy to glue the hinges.
- Tape the ailerons in the plane of the wing.
- Thread the adjustable horn brackets onto the torque rods. Thread the snap-link onto the aileron pushrod and attach the snap-link to the horn bracket.
- With the servo in the neutral position, bend and cut the aileron pushrod and connect to the servo arm. Press a nylon retainer over the wire at the servo arm.

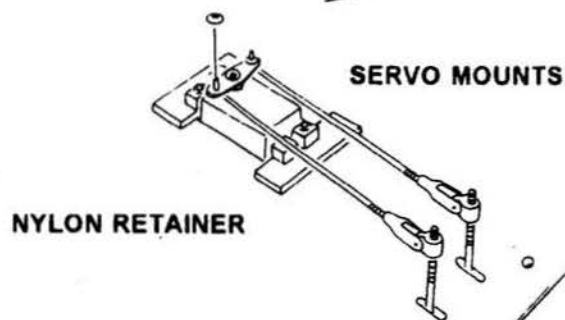

9. Install the TANK TRAY into the slots in the fuselage.
- Rubberband the the fuel tank to the tank tray. Remember to insert the foam between the tank and the tray.

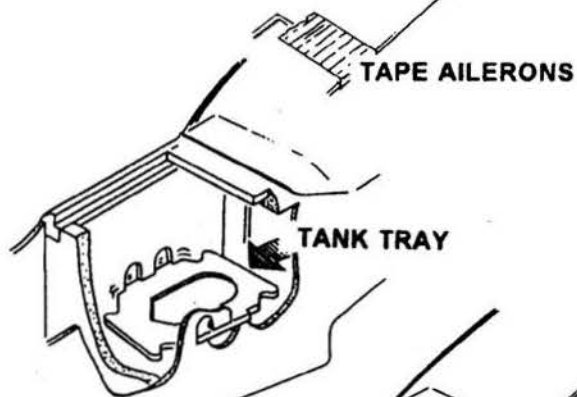

10. Install the radio system. Refer to the **GENERAL INFORMATION BOOK** and the guidelines that came with your radio system for specific details.

11. The location of the center of gravity (C.G.) is very important. Refer to the **PLAN** for the location and to the **GENERAL INFORMATION BOOK** for the balancing procedure.



CONTROL SURFACE TRAVELS

Use the control surface travel gauges to correctly set up the surface deflections. The gauges provide you with two settings, a gentle response setting and a more aerobatic setting. We encourage you to start out using the gentle marks and to move to the aerobatic mode as you progress. If you are using a computer radio, set the transmitter to 100% and adjust the travel settings at the servo arm.

AILERON TRAVEL GAUGE

- Place the gauge anywhere along the wing. Align the center of the aileron to the mark in the neutral position.
 With the control stick full left and right, match the center of the aileron to the mark.
- Adjust the horn bracket as high as possible on the torque rod and position the pushrod in the hole on the servo arm to achieve the desired surface travel.

Note: This is a good time to check and make sure the control surfaces go the correct way. You wouldn't want to correct a left bank with more left, so check it now!

ELEVATOR TRAVEL GAUGE

- Place the elevator gauge anywhere along the elevator hinge line.
- Clip the pushrod to the end hole on the control horn.
 Position the servo end of the pushrod in the hole on the servo arm to achieve the desired surface travel.

RUDDER TRAVEL GAUGE

- Position the rudder gauge at the top of the fin at the hinge line. Follow the same procedure used for the elevator to realize your desired travel.
 Connect the steering pushrod to the servo. Check the plan for proper orientation.

YOU HAVE COMPLETED THE CONSTRUCTION OF YOUR TIGER 2. NOW GO TO THE GENERAL INFORMATION BOOK AND READ THE "FLYING" SECTION.

