



P.O. BOX 788 URBANA, ILLINOIS 61801 (217) 398-8970

Super Aeromaster Biplane Instruction Book

Congratulations on your purchase of Great Planes' Super Aeromaster, a revised version of Lou Andrews' Aeromaster Too Biplane!

You now own one of the best looking classic biplanes on the market today! This updated version by Great Planes has a built up cowl with ABS plastic cowl front, ABS plastic wheel pants, a nylon motor mount for use with 2-cycle engines, bolt on wings and the capability of flying with either a 2 cycle or a 4 cycle engine. Redrawn plans, this instruction book and a new photo sheet are also included. However, we at Great Planes have not changed The Aeromaster Too's great lines or flying characteristics. We did however give the Super Aeromaster a more exciting look without sacrificing any performance.

WARNING!

This R/C kit and the model you will build is not a toy! It is capable of serious bodily harm and property damage. **IT IS YOUR RESPONSIBILITY AND YOURS ALONE** — to build this kit correctly, properly install all R/C components and flying gear (engine, tank, pushrods, etc.) and to test the model and fly it *only* with experienced, competent help in accordance with all safety standards and common sense as set down in the Academy of Model Aeronautics Safety Code. It is suggested that you join the AMA and become properly insured before you attempt to fly this model. **IF YOU ARE JUST STARTING R/C MODELING, CONSULT YOUR LOCAL HOBBY SHOP OR WRITE TO THE ACADEMY OF MODEL AERONAUTICS TO FIND AN EXPERIENCED INSTRUCTOR IN YOUR AREA.**

Academy of Model Aeronautics
5151 East Memorial Drive
Muncie, IN 47302-9252
(800) 435-9262



P.O. BOX 788 URBANA, ILLINOIS 61801

It is a good idea to obtain the following items before you start building as you will need to install or test fit some of them before assembly is complete. You'll need the tools below to help you build the Super Aeromaster:

Items needed:

4 channel radio
 .60 size 2 cycle engine or
 .90-1.20 size 4 cycle engine
 Glass cloth, 4" wide
 Pushrods, Clevises/Connectors
 Propeller
 5/32" wheel collars-4
 3/32" wheel collars-2
 3" wheels-2
 1" wheel-1
 12 to 14 oz. fuel tank/tubing
 AMA safety nut spinner
 Heat shrink covering material
 Great Planes Kwik Strype Tape
 Cyanoacrylate glue
 Epoxy
 Foam rubber
 wing seating tape

Tools or Supplies needed:

Rubber bands or clamps
 Flat building board
 "T"-Pins
 X-Acto knife, hobby saw
 Ruler
 Masking Tape
 Small screw driver-ball driver
 Pliers
 Drill/various size bits
 Sandpaper block and/or T-bar
 Sandpaper-coarse to fine grades
 Waxed paper or kitchen wrap
 Work table or area
 Heat sealing iron
 Heat gun
 Balsa Filler

We suggest that you identify all the parts and mark them accordingly. Use the parts lists and plans to help identify the parts. It is a good idea to leave the die cut parts intact until you need them to avoid loss. You can mark the die cut parts using the drawings provided below. (If there are any missing or incorrect parts, please let us know before you start building!

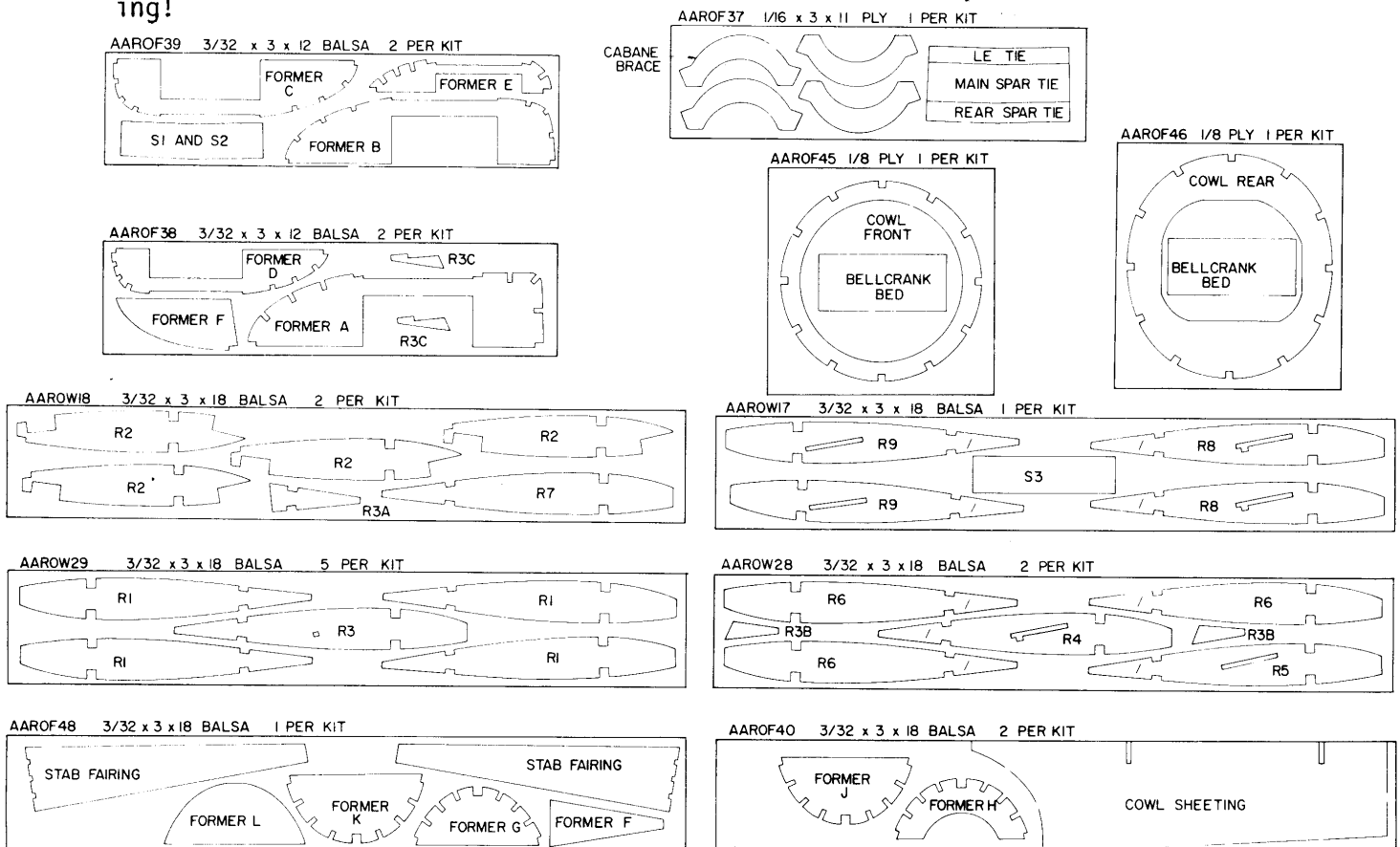

Please read through this instruction book and look over the plans. This way you will have a general idea of how the Super Aeromaster is built.

The cyanoacrylate glues (CA or instant) that are available today (Zap, Hot Stuff, Super Jet) are great products to use on balsa construction. The thin CAs will penetrate balsa to give a strong bond. Hold the pieces together to be glued, apply a small amount of glue to the joint, hold for a few seconds and you're done! Thick CA glues work well on plywood, hardwood, or plastic parts where you put a small amount of glue on one piece to be glued. The glue will sit there and wait for you to position the piece to be bonded to it. You will not have time to move the piece once it is place however. A few seconds later the pieces are permanently glued together. When using these glues or other glues, make sure the parts fit first before you glue them. When we say "trial fit" the parts that is what we mean.

If you need time to position pieces correctly or need extra strength, use epoxy type glues. Use epoxy on plywood parts like firewalls and balsa parts like gluing two wing panels together. Five minute epoxy (it cures in 5 minutes) is great for most applications. If you need longer time use 15 or 30 minute epoxy. You need not use large amounts of epoxy. Squeeze out equal amounts of epoxy and hardener. Mix these together. Coat one piece with epoxy; squeegee the excess glue off with scrap wood. The epoxy glue will work better if there isn't too much oozing out at the edges of the glued piece. Wipe off any of this excess glue or you will have a hard time gluing anything else to the pieces such as 1/4" square bracing around the engine box for a 2 cycle engine.

Your work area ideally should be large and comfortable enough for you to work without having to put everything away every night. (The kitchen table is not recommended!) The key to a straight fuselage and warp-free wings is a straight, flat building board. Remember, your model is only as straight as the board you build on. Have all your tools handy and your building will go much easier.

Build over the plans when instructed. Cover the plans with waxed paper so you don't glue the model to the plans! If the parts do not match the plans exactly, it is because the plans have changed size with the moisture in the air. Do not be concerned about this. The parts were all cut to fit each other. Use the plans as a guide.

Remember this: In order for your Super Aeromaster to perform as it should it is your responsibility to take your time when building and to follow all the instructions given. A careful builder will produce a model that is straight, true and warp-free. A well built model performs best and will fly like it was designed to. So take your time and enjoy!

The building instructions follow on the next page. If you have any questions about building or flying the Super Aeromaster, please call us at (217) 367-2069 and we'll be glad to help.

The photo sheet provided has photos that are in order according to the steps in this instruction book. Hopefully the photos will clarify any question you might have when you are building. The numbers in parentheses after the main headings in various steps indicate which photo will help at that particular step. Some photos will help at more than one step such as wing construction where the wings are similar.

THE TAIL SECTION

1. GLUE ALL FIN PARTS TOGETHER

- Cover the plan in the area of the tail section with waxed paper.
- Line up the fin front, center and rear pieces and pin them over the waxed paper covered plans. Glue these parts together.
- Use 1/4 x 3/4 x 20-3/4 balsa to make the fin top. Cut a piece to length and glue it to the fin. Remove the fin from the building board after the glue is dry and sand the fin top to shape.

2. GLUE THE RUDDER PARTS TOGETHER

- Cut the rudder top and bottom pieces to length from the 1/4 x 3/4 balsa.
- Pin the rudder over the plans. Pin and glue the top and bottom pieces to the rudder.
- Remove the rudder from the board and sand the top and bottom pieces to shape using the plans as a guide.

3. CUT HINGE SLOTS IN THE FIN AND RUDDER (1) (See Photo #1)

- Draw centerlines down the trailing edge of the fin and the leading edge of the rudder.
- Lay the fin over the plan. Mark the hinge slots.
- Lay the rudder in position next to the fin. Transfer the marks for the hinge slots to the rudder. There are two hinges in the fin and three in the rudder. The bottom hinge of the rudder glues to the fuselage later.
- Note: Hinge slotting knives are available commercially and work quite well. An X-Acto knife can also be used. Using one of these knives, cut hinge slots on the centerline you drew. Make sure that the slots you cut are straight into the wood and that the cuts are parallel to the surface of the piece you are working on. This insures that the hinges will be in the center and that the control surface (rudder in this case) will move correctly. Trial fit the hinges to check your work. Do not glue the hinges yet!

4. FINAL SAND THE FIN AND RUDDER

- Tack glue the rudder to the fin. Use a very small amount of glue at only a couple of places. You want to be able to remove the rudder later.
- Use medium grit sandpaper and sand the fin and rudder to the shapes shown on the plans including the rounded edges. Leave the bottom of the fin alone.
- Now remove the rudder from the fin and round the leading edge of the rudder as shown on the plan. Leave the trailing edge of the fin as is.

5. BUILD THE STABILIZER

- Trial fit the stabilizer front and rear pieces together and sand if necessary for a good fit.
- Glue the stab pieces together on your flat building board and pin them in place while the glue is drying.
- Draw a front to rear centerline down the top side of the stab.

6. CONSTRUCT THE ELEVATOR

- Glue 1/8 x 1/4 balsa (cut from 1/8 x 1/4 x 24 stock) to the angled inside edges of each elevator. Sand the 1/8 x 1/4 balsa even with the leading edge and trailing edge of the elevator.
- Draw centerlines down the elevator leading edges.

7. DRILL HOLES IN THE ELEVATOR HALVES FOR ELEVATOR JOINER WIRE

- Position the elevators over the plan. Center the elevator tie over the elevators.
- Mark the hole positions for the elevator tie on each elevator half.
- Drill 3/32" holes for the elevator tie straight into the center of the leading edge of both elevator halves. Keep the drill bit centered so you won't drill through the elevator top or bottom.

8. GROOVE OUT THE ELEVATORS FOR JOINER WIRE CLEARANCE

- Cut a 3/32" groove in both elevator halves so the joiner wire will be flush with the leading edge of the elevators. A brass tube which has been sharpened at one end on the inside with an X-Acto knife makes a good tool for this job.
- Trial fit the wire. Make sure the elevator lays flat with the wire in place. Note: Do not glue the joiner wire to the elevator halves until after the pieces are covered later.

9. GLUE ON THE STAB/ELEVATOR TIP PIECES

- Pin stab and elevator down on the building board aligning the stab with the elevator. Tape the pieces together.
- Cut one piece of 1/4 x 3/4 stock about 7" long for each stab/elevator tip.
- Glue the tip stock in one piece to each tip.
- When the glue is dry, remove stab/elevator from work surface and sand the tips to the shape shown on the plan.

- Cut through the tip stock with a saw to separate the elevators from the stabilizer. Remove the tape.

10. MARK AND CUT THE HINGE SLOTS IN THE STABILIZER AND ELEVATOR (2)

- Draw centerlines down the trailing edge of the stab and the leading edge of the elevators.
- Lay the stab over the stab drawing on the plans. Mark the 3 hinge locations on the left side of the stab.
- Turn the stab over, line it up over the plans and mark the 3 hinge locations on the right side of the stab.
- Line up the elevators to the stab. Extend the hinge location marks onto the elevators.
- Cut the hinge slots in the stab and elevators. Trial fit the hinges.

11. SAND THE STAB AND ELEVATORS TO THE SHAPE SHOWN ON THE PLANS

- Tack glue the elevators to the stab.
- Sand the edges of the stab front, tips and elevator to the rounded shape as you did for the fin and rudder. Leave the trailing edge of the stab as is.
- Remove the elevators from the stab.

THE FUSELAGE

The Super Aeromaster can be flown with either a .60 2 cycle or a .90 to 1.20 4 cycle engine. The position of the firewall as shown on the plans will accommodate the 4 cycle engines available such as the OS Max FS 90. You will need to buy a motor mount for your particular 4 cycle engine. Tatone, for example, has motor mounts to fit four cycle engines. If you plan to use the smaller 2 cycle engines such as an OS Max .61, an engine box (plywood parts supplied) glued to the front of the firewall is used along with the motor mount provided in the kit. The cowl, when constructed, will accommodate either a 2 cycle or a 4 cycle engine. Instructions follow for both types of engines.

Note-The Super Aeromaster has been designed without any engine right thrust at all. We feel that this set up is a benefit to the overall flight performance of the model. However, if you feel that in your particular situation the right thrust would be a benefit, we suggest that you obtain an Ernst thrust plate of approximately 2 degrees and install it behind the engine mount.

1. PREPARE THE FIREWALL

(FOUR CYCLE ENGINES) (3)

Note: Side mount your 4 cycle engine for a better fit under the cowl.

- Position your engine on your mount. Use CA and tack glue the engine to the motor mount.
- Mark the thrust line and centerline on the firewall front.

- Position the engine assembly on the firewall so the shaft is centered over the thrust line and center of firewall with the engine side mounted.
- Mark the holes to be drilled for the motor mount onto the firewall.
- Drill the holes for the motor mount and install the blind nuts (6-32 screws and blind nuts are provided).
- Lay the engine/mount over the plans. The thrust washer should be 1/8" or so beyond the cowl front. Modify the cowl stringer length on the plan if you need more room for your engine.

(TWO CYCLE ENGINES)

- Mark the position of the engine box on the firewall.
2. PREPARE ALL REAR FORMERS A,B,C,D AND E AND THE 1/16" PLY CABANE STRUT SUPPORTS (4)
- Carefully remove all former halves from the die cut sheets.
 - Glue the halves together on your flat building board.
 - Cut cross braces from 1/8 x 1/4 x 24 stock and glue the braces to the formers.
 - Remove the 1/16" ply strut supports from the die cut sheet; glue two supports together. Make two sets.
3. MARK AND CUT THE PUSHROD EXIT HOLES AT THE REAR OF THE FUSELAGE SIDES
- Mark the exit hole positions.
 - Cut the exit holes. Your sharpened brass tube works great here. Use one with a 3/16 diameter or so. Turn the tube by hand and cut an elongated hole for each exit by laying the tube down on the fuse side and then raising it to about a 20 degree angle. This will allow the pushrod to exit at the angle shown.
4. GLUE THE 3/16" Balsa FUSELAGE SIDE TO THE BOX-LOK FUSE SIDE
- Glue the Box-Lok pieces to the inside of the main fuselage sides. The grooves of the Box-Lok pieces should face away from the fuselage sides. Line these pieces up carefully. Note: Make sure you make a right and a left fuse side! The straightest side of the main fuse side is the top. (There is a slight angle at the rear for the stab saddle.) The Box-Lok pieces are interchangeable but they do have a front and a rear. The vertical slots are closer to the front of the Box-Lok pieces.
5. GLUE THE 1/2" Balsa WING BED TO THE FUSELAGE SIDES (5)
- Line up the wing bed to the bottom of the fuse sides. The rear of the wing bed should line up with the rear of the Box-Lok pieces.
 - Glue the wing bed in position to the fuse side.

6. MARK THE POSITION OF FORMER K AND FORMERS A,B,C,D AND E ON THE INSIDE OF EACH FUSE SIDE (6)

- Lay the right fuse side on the plan, inside facing up.
- Mark the positions of the formers on the fuse sides (A,B,C,D,E).
- Lay the left fuselage side next to the right fuselage side, line the sides up carefully and extend the former position marks onto the left side.

7. GLUE IN THE 3/16 PLY CABANE STRUT SUPPORTS

- Trial fit two of the small grooved blocks in the vertical grooves flush with the top of the fuse sides.
- Trial fit the long grooved support block in the horizontal groove between the two small blocks. Repeat the above for the other fuse side.
- Glue the blocks in place with epoxy.

8. GLUE THE 1/4" PLYWOOD FIREWALL INTO THE FRONT SLOTS OF EACH BOX-LOK FUSE SIDE, JOINING THE FUSE SIDES TOGETHER AT THE FIREWALL (7)

- Position the fuse sides upside down over the top view of the plan and at 90 degrees to the building board.
- Trial fit the firewall into the front slots of the fuse sides. Make sure the firewall is upside down. The angle on the firewall bottom matches the angle on the wing bed.
- Making sure the fuse sides are straight over the plans and at 90 degrees to the building board, glue the firewall to the fuse sides with epoxy. Clamp or pin the assembly together until the glue is dry.

9. GLUE THE TWO 1/4 x 5/8 x 3-3/8 Balsa REAR BOX-LOK TIES INTO THE REAR SLOTS, TOP AND BOTTOM, BETWEEN THE FUSE SIDES (8)

- Make sure the fuselage is still straight over the plan top view and that the fuse sides are still 90 degrees to the building board.
- Glue the two Box-Lok ties to the fuselage.

10. GLUE IN THE FRONT AND REAR 1/4 PLY HOLD DOWN PLATES (9)

- Trial fit the plates at the locations shown on the plans. Note: The plates are 1/16 inside the wing saddle opening.
- Use epoxy and glue the plates in position.

11. GLUE IN THE 1/8" CABANE WIRES; GLUE IN THE LOCK PLATES; SOLDER WIRE CABANE BRACES TO CABANE WIRE

- Remove the fuselage from the building board and turn it right side up. Align the fuselage over the plan top view.

- Trial fit the cabane wires into the ply strut supports. Check to see if the wires are even and parallel with each other and that the cabane wires are parallel to the firewall. Adjust as necessary.
 - Use epoxy and glue in the cabane wires.
 - Using epoxy, glue the 1/8" lock plates in position over the wire.
 - Keeping the cabanes aligned correctly and using the wire provided, wrap the 3/32" wire cabane braces to the cabanes on each side of the fuselage. See the plan for location.
 - Solder the cabane braces to the cabanes at the location of the wrap wire. Use low temperature silver solder and follow the directions carefully.
12. GLUE THE 1/16" PLY STRUT SUPPORTS ACROSS THE TOP OF THE FUSELAGE BETWEEN THE WIRE STRUTS (10)

- Use epoxy and glue the supports to the wire and to the top of the fuse sides and lock plates.
13. MAKING SURE THE FUSELAGE IS LINED UP STRAIGHT OVER THE PLAN TOP VIEW, GLUE THE FUSE SIDES TOGETHER AT THE TAIL
- Slightly sand the insides of the fuselage sides at the tail so they fit together as shown on the plan top view.
 - Line the fuselage up over the plan top view. Use some scrap 1/8" balsa or ply under the front of the wing saddle to position the fuselage parallel to the work surface.

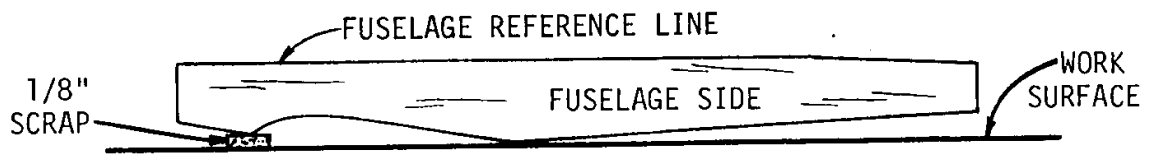

- Imagine a line drawn down the center of the fuselage along the top of the fuselage side. This "Fuselage Reference Line" will be parallel to the work surface when the fuselage is aligned correctly.
- Pull the fuselage sides together at the tail. If one or both fuse sides do not bend as you'd like, wet them with water to relieve the tension in the wood. Be sure that the tail of the fuse lines up exactly over the plan.
- Glue the fuse sides together at the tail.

14. GLUE IN THE REAR FUSELAGE FORMERS A,B,C,D AND E (11)

- The fuselage should still be pinned to the work surface with the 1/8" scrap pieces under the front of the wing saddle.
- Use epoxy and glue in the five rear formers starting with former A and working back. Use a right triangle to see that the formers are 90 degrees to the work surface. The formers should also line up on the marks you drew earlier. Clamp the fuselage and formers in place until the glue is dry.

15. GLUE ON THE TOP FORMERS G,H,J AND K TO THE FRONT PART OF THE FUSELAGE

- Remove the formers from the die cut sheet. There are two H formers and two J formers.
- Center the formers on the top of the fuselage sides so the cowl sheeting will fit correctly later. Glue a former H on either side of the front cabane. Glue a former J on either side of the rear cabane. Former G glues 3/32" back from the front of the firewall to leave room for former L. Use former L as a spacer. Glue former K at the location you marked earlier.
- Make sure the formers are 90 degrees to the top of the fuselage when you glue them in position.
- Cut off one corner of each of the two 1/8 x 3/4 x 3/4 plywood cowl support plates and glue them to the back of former G next to the stringers.

16. INSTALL PUSHRODS IN THE FUSELAGE

- Use a flexible cable in a tube type pushrod for the throttle linkage. Drill a hole through the firewall at the appropriate place for your engine throttle location. Allow for placement of the engine box if you are installing a 2 cycle engine.
- Glue the outer tube in position. Brace the tube with scrap wood at various positions along the tube's length so it stays in position.
- Use wire in a tube style pushrods for elevator and rudder linkage. Glue the outer tubes in position at the exit holes and at braces along the tubes' length. Cut the tubes off at the exits and sand them even with the fuselage sides. Run these tubes as straight as possible so the inner wires won't bind.
- Leave all tubes extra long in the radio compartment until you decide where the servos will go.

17. TRIAL FIT YOUR ASSEMBLED FUEL TANK INTO THE FUSELAGE (12)

- Now is the time to plan for your fuel tank installation. A 14 ounce tank is recommended. Place the tank as high as you can in the nose of the fuselage. Cushion the tank with foam rubber and check the fit. Modify the fuse if necessary for your tank. Drill the holes for fuel tubing through former G.
- Remove the tank for now. However, if you leave the tank in place, plug the fuel lines to keep out dirt and dust.

18. GLUE IN ALL THE 1/4 x 1/4 AND ALL 1/8 x 1/4 STRINGERS TO THE TOP AND BOTTOM OF THE FUSELAGE (13, 14, 15)

- Start by gluing the 1/4 x 1/4 stringers in place. Cut to size and glue in place. Note: The 1/4 x 1/4 stringer at the top rear of the fuselage glues from former A to beyond former E. The stringer is cut off at an angle to match the fin front. Wait until you mount the fin to cut this angle.

Cut to length and glue in the 1/8 x 1/4 stringers. The 1/8 x 1/4 stringers on the bottom rear of the fuselage need to be custom cut and sanded to fit at the back next to the 1/4 x 1/4 stringer you glued in first. Two of the stringers butt to the front of former E. The rest taper to the rear of the fuselage. Cut the long stringers first. The scrap can be used at the front of the fuselage. This gives you extra stringers so you can be selective on which ones to use.

The 1/8 x 1/4 stringer that is just above the fuse side runs from former G and butts to the front of former A, leaving the notch open for another stringer to be added after the cowl sheeting is added. Sand this stringer to fit. This other stringer (1/8 x 1/4) butts to the rear of the cowl sheeting and glues into all notches from former A to former E. This stringer therefore glues to the other 1/8 x 1/4 stringer that runs from G to A. Glue the cowl sheeting on in the next step before you glue on this next stringer.

19. GLUE THE COWL SHEETING TO THE STRINGERS AND FRONT FORMERS (16)

Sand the stringers at the front of the fuselage so the cowl sheeting will mate correctly.

Wet the cowl sheeting with a 50% solution of water and ammonia. Bend each cowl sheeting piece in position over the front formers and stringers and hold it in place with rubber bands until the balsa wood is dry.

Glue the curved sheeting in place. Fill in the slots below the cabane wires with balsa filler. Sand to shape when dry.

20. GLUE IN THE LAST 1/8 x 1/4 STRINGER (17)

Butt glue this stringer to the end of the cowl sheeting and run it back to former E, gluing it into all the notches as you go.

21. CUSTOM CUT FILLETS AND GLUE THEM BETWEEN THE STRINGERS AT THE REAR OF THE COCKPIT TOP AND BOTTOM (18)

Use 3/32" balsa scrap from the die cut sheets for fillet material.

22. GLUE FORMER L TO THE FRONT OF FORMER G

Sand the front of former G first, then glue L in place.

23. GLUE FORMER F TO THE FRONT OF FORMER A (19)

Sand the front of former A first. Glue the three former F pieces together on a flat surface. Glue former F to the front of former A.

24. GLUE IN THE 1/8 x 1/4 PIECES AT THE STAB SADDLE (20)

Cut pieces to fit between the back of former E and the tail on the inside of the fuse sides. Sand these pieces to a taper so they fit together.

Glue the 1/8 x 1/4 pieces in place.

25. ALIGN AND GLUE THE STABILIZER TO THE TOP OF THE FUSELAGE AGAINST FORMER E

- First align the fuselage to your building board as you did before using 1/8" scrap under the front of the wing saddle.
- Lay the stab onto the stab saddle. Center the stab side to side on the saddle by measuring from the fuse side out to each stab tip.
- Measure from each stab tip to a point at the center of the top of former L/G. Each measurement should be the same.
- Measure from each stab tip to the work surface. These measurements should be the same. The leading edge of the stab should be slightly (1/8") higher than the trailing edge because of the built in positive incidence of the stab.
- Mark the fuse and stab so you can line up the stab again.
- Remove the stab and apply epoxy to the stab saddle. Glue the stab to the saddle. Check the alignment again before the glue dries.

26. GLUE THE FIN TO THE TOP OF THE STABILIZER (21)

- Place the fin along the centerline you drew on the stab. The rear of the fin is even with the rear of the fuselage. You will notice a space under the rear of the fin. Fill this space with 1/4" scrap later after the elevators are covered and installed. The front of the fin is against the back of former E and the 1/4" stringer. Cut the angle on the back of the 1/4 x 1/4 stringer now. The fin should also be 90 degrees to the stab. Mark the fin position on the stab and fuse.
- Use epoxy and glue the fin to the fuse and stab. Make sure the fin is 90 degrees to the stabilizer and is lined up along the stab centerline.

IF YOU ARE INSTALLING A FOUR CYCLE ENGINE, SKIP AHEAD TO STEP 30

27. PREPARE THE 1/4" PLYWOOD ENGINE BOX FRONT (TWO CYCLE ENGINES ONLY) (22)

- A 2 cycle engine should be mounted inverted on the nylon mount provided. Hold the engine /mount assembly over the plan so the engine mount is in position next to the engine box front location. Position the engine on the mount so that the thrust washer is about 1/8" beyond the cowl front. Mark the engine position on the mount.
- Mark and drill the holes for the 6-32 engine mount screws in the ply 1/4 x 2-1/2 x 2-1/2 engine box front.
- Install the 6-32 blind nuts in the engine box front.

28. BUILD THE ENGINE BOX (TWO CYCLE ENGINES ONLY)

- Lay the engine box front face down. Position the top, bottom and side pieces on the engine box front. The side pieces fit inside the top and bottom pieces. The outside of all four pieces should be flush with the outside of the front piece.
- Use epoxy and glue the engine box pieces together.

29. GLUE THE ENGINE BOX TO THE FIREWALL (TWO CYCLE ENGINES ONLY) (23)

- Use epoxy and glue the engine box to the firewall in the position shown on the plan. Remember your 2 cycle engine should be mounted inverted so glue the box on correctly. Note: The box glues to former L also.
- Glue the 1/4 x 1/4 balsa bracing on all four sides of the engine box next to the firewall.

30. BUILD THE Balsa COWL (24,25,26,27)

- The cowl is built with a front and a back piece, stringers in between and sheeting over the stringers. Follow these instructions to get the shape of the cowl shown on the plan (the cowl is taller in back than the front and also slightly wider in the back). Stringers are 3/16".
- Drill clearance holes for 6-32 bolts in the cowl rear at the positions shown on the plans. These bolts hold the cowl onto the fuselage. On 2 cycle engine installations it may be necessary to alter the locations of the lower cowl attach screws to clear your particular engine/muffler set up.
- Four cycle engine only: Hold the engine/mount assembly over the plan so the engine mount is next to the firewall location. Position the engine on the mount so the thrust washer is about 1/8" beyond the cowl front. Mark the engine position on the mount. (You already did this for 2 cycle engines.)
- Lay the 1/8" ply cowl rear piece over some waxed paper on a flat surface. Position four stringers, cut slightly oversize, and the front cowl piece in position to the rear cowl as follows: a stringer in the top notch, the bottom notch and one in each of the side notches.
- Lay a right triangle next to the back of the top stringer. There should be 3/32" of space between the triangle and the top edge of the cowl front piece. Lay the right triangle next to the bottom of the bottom stringer. There should be 1/2" of space there. The two side pieces will have 3/32" of space when a right triangle is held there. Move the front piece so it is parallel to the back piece.
- Here's the trick: Use epoxy on all these glue joints (the four stringers, top and bottom piece) and hold or brace in the above position until dry.

You then have the basic shape of the cowl. The epoxy lets you reposition parts until all are in correct relation to one another. Wait until the glue is dry to proceed.

- Glue in the remaining stringers keeping the cowl braced as before. Let the epoxy dry thoroughly. Sand the stringer ends even with the plywood front piece.

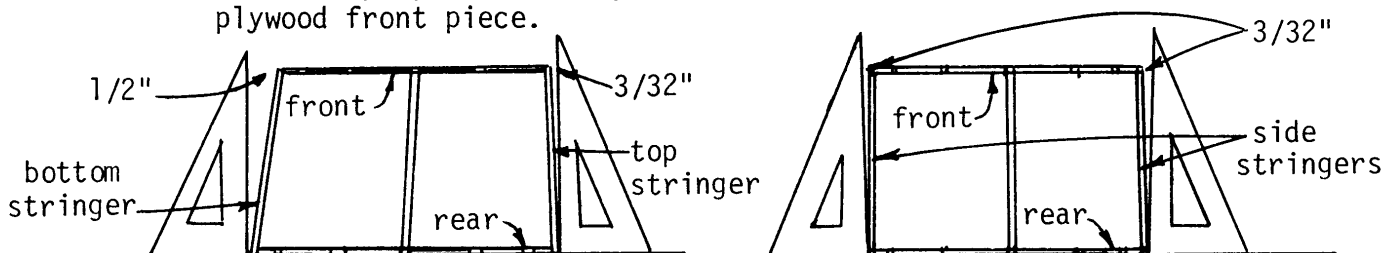

- Sheet the cowl using the 1/8" x 3-1/4" x 36" balsa provided. Cut the balsa into six pieces slightly longer than the cowl. Start with the top piece first, then glue on the bottom piece. Cut the pieces so they meet the next piece of sheeting in the middle of the stringer. Alternate sides until you are finished.
- Sand the sheeting even with the cowl front and rear. Sand the glue joints in the sheeting.

31. GLUE THE ABS COWL FRONT TO THE Balsa COWL; GLASS THE COWL (28)

- Remove the area of the cowl shown on the plan.
- Slightly sand the plastic cowl where the glue joint will be.
- Add some small custom-shaped balsa blocks from scrap to act as braces between the inside edges of the cowl and the ply cowl front. Glue in at least four of these blocks.
- Center the plastic cowl over the front of the balsa cowl. Use thick CA glue and glue the plastic cowl front to the cowl.
- Use 3/4 ounce glass cloth and glass the entire balsa cowl, overlapping the plastic cowl seam about 1/8". Use polyester resin. Let it dry completely.
- Sand the glass using 120 (medium fine) grit sandpaper.
- Put on a second coat of polyester resin, again letting it dry completely.
- Sand the cowl with 400 (fine wet or dry) grit sandpaper. The cowl is now ready to be primed and painted. This should be done later after fitting the cowl over the engine and cutting away the appropriate areas.

32. ATTACH THE COWL TO THE FUSELAGE (29)

- Hold the cowl in position against the firewall (the top of the cowl is even with the top of the fuselage). Tack glue or tape the cowl in this position. Cut away the cowl back to clear the engine box if necessary.

- Working through the hole in the front of the cowl, mark the hole positions onto the front of the firewall and the front of former L.
- Remove the cowl and drill the holes for 6-32 blind nuts through the firewall and former L and the plywood pieces behind it. Install the blind nuts. Epoxy the nuts in place.
- Trial fit the cowl to the fuselage using 6-32 bolts.

33. CONSTRUCT THE MAIN LANDING GEAR (30)

- Locate the 5/32" main gear wires, the 1/8" main gear brace and the two 3/32" main gear braces.
- Put the 5/32" main gear wire in the rear slot and the 1/8" wire brace in the front slot of the gear bed. Tape parts together. If you fly off grass, position the parts as shown in the photo, only do not use the shim. If you fly off pavement, use the 1/2" shim shown under the gear bed. In either case, the gear bed will be 90 degrees to the work surface when the axles are touching the work surface. (The plan shows the grass field set up.)
- Wrap the main gear and braces at the places shown on the plan using the soft wire provided. Solder the wrap wire to the gear wire after rechecking the positions of the wire parts. Use one 12" piece of wire at each of the six solder/wrap positions. Use low temperature silver solder and follow the manufacturer's directions carefully.

34. GLUE IN THE 3/8" Balsa BOTTOM BLOCK TO THE FUSELAGE

- Glue the two 3/8 x 2 x 2 blocks together so the grain runs front to rear. Note the angles at the front of the blocks.
- Glue the completed bottom block to the bottom front of the fuselage below the firewall. Line up the angle to the front of the firewall.

35. GLUE THE 3/8" PLYWOOD LANDING GEAR PLATE TO THE BOTTOM OF THE FUSELAGE (31)

- Glue the landing gear plate to the fuse bottom behind the bottom block. Use epoxy. Note: Make sure the widest slot (5/32") is toward the rear of the model and that the plate is centered over the fuselage.

36. ADD TAILWHEEL ASSEMBLY TO THE FUSELAGE (32)

- Final sand the end of the fuselage where the tailwheel assembly will be.
- Cut a slot in the rear of the fuselage for the nylon bearing.
- Glue the nylon bearing into the slot in the fuselage. Be careful not to get glue into the bearing as the tailwheel strut must be moveable.

37. ADD THE STAB FAIRING SHEETING (33)

- Cut out parts of former E between the stringers so the sheeting will fit. Glue the sheeting in place. Sand to blend in with the rear of the fin.

WING CONSTRUCTION

READ THIS FIRST!

Name	Dihedral	Shape	Span
Top Wing A (short)	no	swept	48"
Bottom Wing B (short)	yes	straight	48"
Top Wing C (long)	no	swept	52-1/2"
Bottom Wing D (long)	no	swept	52-1/2"

The Super Aeromaster can be built with three different configurations. Decide now which one you will build. Configuration #1 has two short wings, Configuration #2 has one long and one short wing and Configuration #3 has two long wings. See the information on each wing here to help you decide which wings to build. Flight characteristics are similar so the choice can be based on the desired wing area and visual appearance.

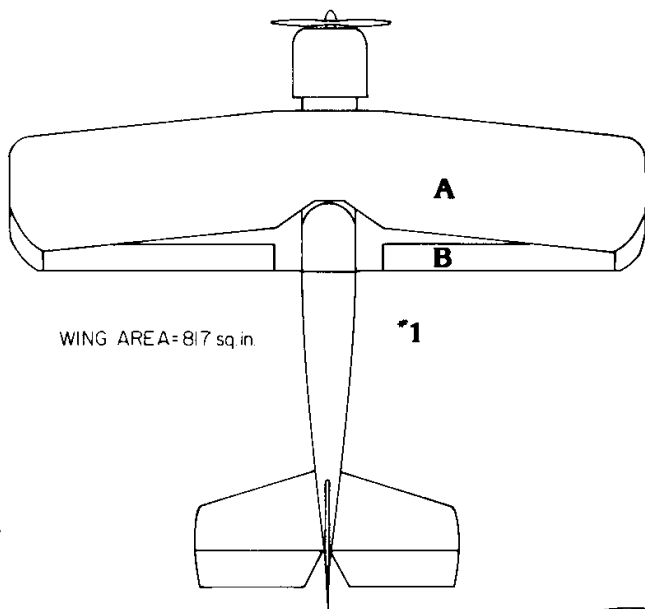

WING AREA = 817 sq. in.

#1

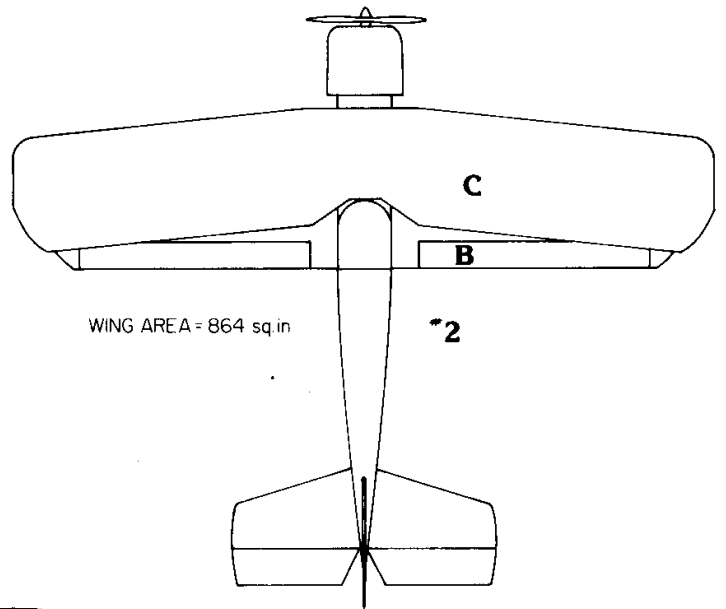

WING AREA = 864 sq. in.

#2

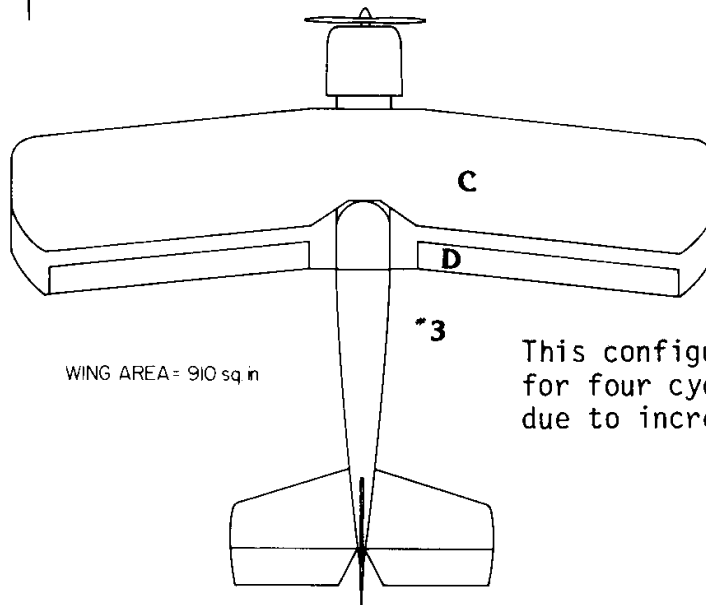

WING AREA = 910 sq. in.

#3

This configuration is suggested for four cycle engine installation due to increased flying weight.

Construction for all four wings follows. Make sure you build over the correct plan of the wings you want to build. The wings are similar in construction. Note however the slight differences as you read the instructions.

TOP WING A AND C (Configuration 1,2 and 3)

These wings are built flat with no dihedral and are built in one piece. Large wing C has the same number of ribs, they are just spaced farther apart. All wings are semi-symmetrical. The ribs and leading edge have a top and bottom. Refer to the plan before proceeding.

1. PREPARE THE MAIN SPAR, REAR SPAR AND LEADING EDGE (34)

- Lay the plans on a flat work surface and cover them with waxed paper. Use a small saw and cut all the angles needed to build one 3/8 leading edge, two 1/4 x 1/4 main spars and two 1/8 x 1/4 rear spars. The spars should be hard balsa with straight continuous grain. Do not use soft or cracked balsa for these pieces. We have included 4 extra 1/4 x 1/4 pieces for jig shims. Glue all these pieces together over the plan.
- Cut spars and leading edge to length shown on the plan. Note that the spars end in the middle of the end ribs that are glued together. Sand the leading edge at the center to match the rest of the leading edge shape.

2. PIN 1/4 x 1/4 x 24 Balsa SHIMS TO THE PLAN

- The front shim is placed under the leading edge of the wing. The rear shim is between the rear spar and the end of the ribs. See the plan for exact location.
- Pin the shims in place.

3. PREPARE THE WING RIBS (35)

- Remove the eight center section ribs (R2) and sixteen R1 ribs from the die cut sheets.
- Glue two R2 ribs together. Make three sets.
- Glue two R1 ribs together. Make two sets.

4. POSITION ALL THE RIBS (INCLUDING THE DOUBLE RIBS) OVER THE PLAN (36)

- Note- Notice that the ribs are semisymmetrical. Make sure you get them all oriented correctly. Use the rib drawings on the plans to help you. Also make sure the notches for the cabane support blocks in ribs R2 are down.
- Make sure the ribs are 90 degrees to the work surface. Pin the R1 ribs in position over the rear shim. Pin the R2 ribs to the work surface at 90 degrees to the work surface.

5. GLUE THE TOP MAIN AND TOP REAR SPARS TO THE RIBS (37)

- Make sure you don't lose the rib alignment when you glue the spars to the ribs.

6. GLUE ON THE LEADING EDGE

- Remove the pins from the leading edge shim so they are not in the way. Place the leading edge on the shim. This will place the leading edge in the correct position.
- Put waxed paper between the leading edge and the shim so you don't glue the shim to the leading edge.
- Glue the leading edge to the ribs.

7. GLUE THE TRAILING EDGE TO THE RIBS

- Notice that the angles are not the same on the trailing edge stock. The 90 degree angle glues toward the bottom of the rib.
- Glue the trailing edge pieces to the ends of the R1 ribs.
- Trim the trailing edge to length.

8. GLUE ON THE 1/4 x 9/16 x 8 REAR SPAR CAP

- Glue this cap piece to the back of the rear spar and the back of the R2 ribs.

9. GLUE ON THE TWO 1/4 x 9/16 x 3-1/2 CENTER SECTION TRAILING EDGE CAPS

- Shape the parts from the precut parts supplied. Make angle cuts on both ends.
- Glue these caps between the tapered trailing edge and the 8" cap piece.

10. TAPER THE SHORT CAP PIECES FROM THE LARGE CAP TO THE TRAILING EDGE (38)

- Draw lines as shown in photo 38 to guide you in your carving and sanding.
- Carve and sand the caps to the proper contour.

11. TURN THE WING OVER AND ALIGN IT TO THE BUILDING BOARD

- Remove the 1/4 square shims.
- Turn the wing over and pin the top spar to the board. Put the pins in at an angle so they are not in the way when you add the bottom spar. Place the 1/4 x 1/4 shims under the rear spar location to keep the wing panel straight.

12. GLUE THE BOTTOM MAIN SPAR AND THE BOTTOM REAR SPAR TO THE RIB NOTCHES

- Glue the 1/4 square main spar and the 1/8 x 1/4 rear spar to the ribs.

13. GLUE THE TWO 5/8 GROOVED CABANE WIRE BLOCKS TO THE NOTCHES IN THE CENTER RIBS (39)

- Both blocks glue to the first R1 ribs and the notches in the R2 ribs.

14. GLUE IN Balsa FILLERS BETWEEN THE FORWARD CABANE BLOCK AND THE LEADING EDGE (40)

- Remove the wing from the building board.
- Shape scrap filler pieces and trial fit. Excess trailing edge stock can be used as filler here.
- Glue the fillers in place. Realign the wing to the building board with the bottom side up.

15. GLUE ON THE BOTTOM LEADING EDGE SHEETING (41)

Note: This sheeting glues from the front of the leading edge to the rear of the spar and butts together at the center double rib. This sheeting stops at the inside of tip rib R1. Use the 1/16 x 2-1/2 x 24 sheeting provided.

- Cut out the area of the sheeting over the cabane blocks and trial fit.
- Glue the sheeting in place.

16. GLUE ON THE BOTTOM TRAILING EDGE SHEETING

- Use 1/16 x 2-1/2 x 24 sheeting. This sheeting glues from the front of the rear spar to 1/16" beyond the trailing edge piece and butts together at the center double rib. This sheeting also stops at the inside tip rib. Cut the sheeting for cabane block clearance. Trial fit.

- Glue the sheeting in place.

17. GLUE ON THE BOTTOM CENTER SECTION SHEETING (42)

- Use two pieces of 1/16 x 2-1/2 x 24 stock. This sheeting glues from the second R1 rib on one side of the center ribs to the second R1 rib on the other side. Do not cut the sheeting at the center ribs.

- Cut out the sheeting over the cabane blocks.

- Glue the sheeting in place.

18. GLUE ON THE BOTTOM CAP STRIPS

- Use the 1/16 x 1/4 x 36 balsa stock and custom cut the cap strips for the five outer R1 ribs.

- Glue the cap strips in place between the leading and trailing sheeting.

Note the position of the outer rib cap strip. The cap strip outer edge is flush with the double rib outer edge.

19. TURN THE WING OVER AND ALIGN AGAIN USING THE 1/4 SQUARE Balsa SHIMS

Note: When you sheet the top of the wing, you could build in some warps if you don't have the wing blocked up straight on your work surface.

Position the wing on the shims.

20. CUSTOM CUT AND GLUE IN THE 1/16 Balsa VERTICAL SHEAR WEB PIECES BETWEEN THE TOP AND BOTTOM SPARS, MAIN AND REAR (43)

Use the 1/16 x 3 x 24 balsa stock for the shear web pieces. Note that the vertical webbing goes behind the main spars and in front of the rear spars. The webbing also glues between the top and bottom main spars in the wing center section. There is no webbing at the rear spar center section.

21. GLUE ON THE 1/16 Balsa TOP LEADING EDGE SHEETING22. GLUE ON THE 1/16 Balsa TOP TRAILING EDGE SHEETING23. GLUE ON THE 1/16 TOP CENTER SECTION SHEETING24. GLUE ON THE 1/16 X 1/4 Balsa TOP CAP STRIPS

25. GLUE ON THE 3/32" WING TIPS

Trim all sheeting and wing parts even with the outside of tip ribs R1.

Center the wing tips on the center of the tip ribs from the leading edge to the trailing edge. Glue the tips in place.

26. ADD FILLER PIECES TO WING TIP, SAND TO SHAPE AND SHEET TOP AND BOTTOM OF WING TIPS (44,45)

Fit and glue 1/4 square and 1/8 x 1/4 tip spar extensions.

Glue on the filler pieces also. Sand parts to the shape shown on the plan.

Sheet with 1/16" balsa sheeting only at the leading edge and the trailing edge. The center of the wing tip is left open.

27. FINAL SAND THE WING

Round the leading edge slightly as shown on the plan.

Sand all glue joints and wing parts.

STOP HERE FOR NOW AND BUILD YOUR BOTTOM WING

BOTTOM WING B (CONFIGURATION 1 AND 2)

This wing is built in right and left panels and then joined before it is sheeted. The wing has 1-3/16" dihedral as shown on the plan.

1. PIN THE 1/4 SQUARE SHIMS OVER THE PLAN

Check the plan for location of the shims.

Pin the shims in place.

2. PREPARE THE WING RIBS

Separate two R7, four R3, two R4, two R5, six R6 and four R1 ribs from the die cut sheet for the two wing panels. Note: There is an extra R3 rib you will not use. Also you will not use the die cut sheet with R8, R9 and S3 parts. These are used on Wing D that you are not building.

Glue two R1 ribs together. Make two sets.

Separate the semi-symmetrical ribs into two sets, one for each wing panel.

3. PIN THE MAIN 1/4 x 1/4 BOTTOM SPAR IN POSITION AND PLACE ALL THE RIBS OVER THE MAIN SPAR IN THEIR CORRECT POSITIONS

The main spar ends at the middle of the double R1 ribs. Pin the spar in this position.

Align all the ribs 90 degrees to the bottom spar. Note that the ribs are semi-symmetrical. Make sure you get them all oriented correctly. Use the drawings on the plans to help you identify "up" from "down" on each rib.

Pin the ribs in place on the rear shim.

Use the 1/4 ply wing hold down to position rib R3 that glues next to rib R7. Note that rib R7 should be angled slightly to allow for the dihedral angle. Use the ply spar ties to help determine the angle.

4. GLUE ALL THE RIBS TO THE BOTTOM 1/4 SQUARE MAIN SPAR

Make sure all the ribs except R7 are 90 degrees to the spar and that the spar is fully pulled upwards into the rib spar notches before gluing.

5. GLUE ON THE 1/4 SQUARE Balsa TOP SPAR AND THE TOP AND BOTTOM 1/8 x 1/4 REAR SPARS

Slide the bottom rear spar under the ribs. Glue this spar in first. Be careful not to lose the alignment when you glue the ribs to the spar.

Glue the other spars to the ribs.

6. GLUE THE LEADING EDGE TO THE RIBS

Place waxed paper over the 1/4 shim and under the leading edge of the ribs. You don't want to glue the leading edge to the shim.

- Align the leading edge and glue it in place. Do not glue the leading edge to rib R7. Leave the space here for the plywood spar ties to be added later. The leading edge has a top and a bottom. Position it correctly on the ribs.

7. GLUE ON THE TAPERED TRAILING EDGE

Notice there is a correct way for the trailing edge to fit on the rib ends. The 90 degree angle is on the bottom toward the work surface.

- Glue the trailing edge in position.

8. GLUE IN THE FRONT AND REAR HOLD DOWNS

- Glue the 1/4 ply front hold downs in position between R3 and R7, using the leading edge spar tie as a spacer.

- Glue the shaped rear hardwood hold down in place between R3 and R7.

9. GLUE IN THE 1/2" Balsa FRONT FILLER PIECES (46)

- Glue these fillers above and below the wing hold down plates. Use the spar tie as a spacer. Turn the wing over to glue in the bottom filler pieces.

- Sand the fillers to the rib shape when the glue is dry.

10. BUILD THE OTHER WING PANEL

- Repeat steps 1-9, skipping step #2 if you already separated all the ribs from the die cut sheets.

11. SAND THE OUTER SIDE OF RIB R7 ON BOTH PANELS SO THE SPARS AND LEADING EDGE AND TRAILING EDGE ARE FLUSH WITH THE RIBS (47)

- Do a good job here so you will have a good glue joint. Use a long sanding block or T-Bar.

12. JOIN THE WING PANELS TOGETHER WITH THE SPAR TIES (48)

- Cut out the root R7 rib in two places where the main and rear spar ties will join the wings together. The main spar tie glues in front of the main spars; the rear spar tie glues behind the rear spars.

- Pin one panel down on a flat surface.

- Using epoxy, glue all spar ties, including the leading edge spar tie, to the panel on the work surface. Make sure all ties are securely glued.

- Block up the other panel 1-3/16" at the tip rib R1.

- Keeping the panel blocked up, glue the two panels together at the R7 ribs, gluing the spar ties to the blocked up panel at the same time.

13. ATTACH THE NYLON BELLCRANK TO THE BELLCRANK BED; GLUE THE 1/16" PLY AILERON BELLCRANK BED INTO THE WING (52) (Photo shows wing D here and throughout the rest of these wing B instructions. Wing D is flat and swept. Procedures for building both wings is similar. Use the photos for reference only.)

- Drill holes into the bed and attach the bellcrank and bushing to the bottom of the bed with a 4-40 bolt and hex nut. Use instant glue on the hex nut to keep the assembly from coming loose. Cut off the excess threads on the bolt.
 - Glue the bellcrank and bed assemblies in place in the slots in ribs R4 and R5.
14. GLUE ON THE TOP 1/16 TRAILING EDGE SHEETING AND THE TOP LEADING EDGE SHEETING (55)
- This step should be completed one wing panel at a time with that panel pinned flat over jig shims on your work surface.
- Glue the sheeting in place, butting it at the center.
15. TURN THE WING OVER AND REALIGN IT TO THE WORK SURFACE
- Block up the center of the wing. Pin the wing to the work surface to keep it straight. Place shims under the wing at various places to hold it straight while you do the next steps. Use 1/4 x 1/4 jig shims at the rear spar location to prevent building any twist into the panels.
16. GLUE ON THE BOTTOM LEADING EDGE SHEETING
- Trim pieces of 1/16 x 2-1/2 x 24 balsa to fit. Glue the sheeting in place.
17. GLUE IN SMALL RIBS R3B AND R3C INTO THE AILERONS AND R3A INTO THE WING CENTER SECTION
- Glue two R3B and two R3C ribs into each aileron. Use a 1/32" shim between R3B and the large R3 or R1 next to it. Remove the shim. You will cut along this space later when you cut out the ailerons. The space becomes clearance space for aileron movement.
 - Glue two R3A ribs onto the inboard sides of the R3 ribs as shown on the plans.
18. GLUE THE AILERON HORN BED INTO THE AILERON (56)
- Glue this 1/8" ply piece onto the two R3C ribs. Custom fit the bed so it is even with the bottom of the ribs.
19. MARK AILERON CUT LOCATION ON THE TOP TRAILING EDGE SHEETING (57)
- Using a hobby knife, mark through the sheeting from the bottom side at the slanted die cut lines on each rib. This gives you the cut line position when you cut out the ailerons. Do NOT cut along this line now. Only mark its position at each rib. Similarly mark the outlines at the end of each aileron and the rear of the rear spars.
20. GLUE ON THE BOTTOM TRAILING EDGE SHEETING
- Cut pieces of 1/16 x 2-1/2 x 24 to fit.
 - Glue the sheeting in place.

21. CUT THE STRIP OF BOTTOM TRAILING EDGE SHEETING AWAY FROM THE WING BETWEEN THE REAR SPAR AND THE FRONT OF THE AILERON (58)
- Mark the rear of the 1/8 x 1/4 rear spar on the bottom trailing edge sheeting.
 - Mark the front of the aileron on the bottom trailing edge sheeting. This line is about 7/16" back from the rear spar line.
 - Cut through only the sheeting along these lines. Use a metal straight edge to guide your cuts.
 - Cut this strip of sheeting between the two long cuts at each end. Remove the strip of sheeting. Partially cut the ends of the ailerons loose by cutting through the bottom sheeting along the outboard edge of rib R3 and the inboard edge of the tip rib R1.
22. CUT THROUGH THE RIBS ALONG THE DIE CUT LINES (59)
- Cut along the die cut lines on the ends of ribs R4, R5 and R6.
23. TURN THE WING OVER AND CUT THROUGH THE TOP TRAILING EDGE SHEETING AT THE FRONT OF THE AILERONS; CUT THROUGH THE TRAILING EDGE (60, 61, 62)
- Draw a line along the cut lines you made earlier.
 - Cut through the top trailing edge sheeting along this line using a straight edge to guide you.
 - Cut through the sheeting at both ends of this cut you just made and continue it down to trailing edge of the aileron.
 - Cut through the trailing edge of the aileron. Remove the ailerons.
24. GLUE IN THE 1/4 X 1/4 Balsa FILLERS IN THE AILERONS AT EACH HINGE LOCATION (63)
- Glue the pieces in place on the top sheeting at each of the 4 hinge locations.
25. SAND THE AILERON LEADING EDGE AND REAR SPAR AREA (64)
- Sand the front of the sheeting pieces even with the front of the ribs. Be very careful when you sand to keep the front of the ailerons straight. Use a sanding block or T-Bar longer than the aileron.
 - Cut away the rest of the rib material and sheeting behind the rear spars. Again use a sanding block and be careful to keep the edges straight.
26. ADD THE REAR SPAR CAP AND AILERON CAP; FINAL SAND THE AILERONS (65)
- Use 1/8 x 7/8 x 24 balsa and cut pieces to fit at the rear of the spars and at the front of the ailerons.
 - Lay the ailerons on a flat surface. Pin each wing panel in turn on a flat surface. Glue the four balsa caps in place.
 - Sand the caps so they are flush with the sheeting. Sand the top of the aileron caps to a small "V" shape as shown on the plan in the "Bellcrank to Aileron Linkage" drawing.

27. GLUE IN THE PLYWOOD 1/16 SERVO BED (66, 67)

- Cut away the rib material in the servo bed location. Work from the top side of the wing.
- Glue in S2 at the rear of the servo area between the top and bottom sheeting.
- Make S1 from the other S2 piece, using the drawing on the plan as a template. Glue S1 to the rear of the front spars in the servo bed area.
- Use your servo as a guide for placement of the servo bed in relation to the ribs. Place the servo so the wheel or arm lines up with the pushrod holes in ribs R3. Make provisions for attaching the servo to a servo tray if you want to mount the servo this way. If you use a tray, mount the tray to the servo bed, then glue in the bed. Otherwise, the servo can be attached to the bed via hardwood blocks screwed to the bed. Glue the servo bed to the wing center section.

*28. CUT AND GLUE ALL THE VERTICAL GRAINED SHEAR WEBBING PIECES TO THE SPARS AND RIBS

- Cut pieces of 1/16 x 3 x 24 balsa to fit behind the 1/4 x 1/4 main spars.
- Cut pieces to fit in front of the rear spars (1/8 x 1/4).
- Block up each wing panel in turn on the 1/4 x 1/4 shims as you glue in the shear web to keep the wing straight.

29. GLUE SCRAP 1/16 PLY TO R3 RIBS FOR PUSHROD WIRE SUPPORT (68)

- Cut two pieces of 1/16 x 1/2 x 1/2 from die cut scrap.
- Drill 3/32" diameter holes in each piece to match the rib holes.
- Glue these pieces over the pushrod holes in both R3 ribs next to the center section.

30. CONSTRUCT AND INSTALL THE 1/16" WIRE AILERON SERVO TO BELLCRANK LINKAGE

- Cut the 36" piece of wire to the length shown on the plan.
- Feed the wire through the holes in the R3 and R4 ribs. (or R8 in Wing D)
- Make a 90 degree bend in both ends of the wire.
- Cut a small piece of wire and wrap and solder it at the location shown.
- Attach the ends of the wire linkage to the last hole in the bellcranks.
- Check the assembly to see that it does not bind anywhere when you move the wire back and forth.

* Steps 28 through 41 are also used for Wing D construction.

31. GLUE ON THE TOP CENTER SECTION SHEETING

- The sheeting runs from R4 to R4 in one piece. Cut two pieces of 1/16 x 2-1/2 x 24 to fit, one toward the leading edge and one toward the trailing edge. Carefully re-jig the wing to prevent building in any twists.
- Mark the servo well opening but do not cut it out until the wing center section is glassed.
- Glue the sheeting in place. (Sheeting runs from R8 to R8 in Wing D)

32. GLUE ON THE BOTTOM CENTER SECTION SHEETING

- The center sheeting runs from R4 to R4 at the leading edge. The center sheeting piece at the rear spar runs from R5 to R5. (Sheeting runs from R8 to R8 and from R9 to R9 in Wing D.)
- Glue the sheeting in place. The wing should still be pinned to jig shims to prevent building in any twists.
- Cut out slots for aileron linkage in the bottom center section sheeting.

33. INSTALL THE BELLCRANK TO AILERON LINKAGE (69)

- Tape the top of the ailerons to the top sheeting of the wing in neutral position.
- Cut 1/16" threaded pushrod to length (not supplied).
- Bend the wire at 90 degrees at one end and attach this end to the bellcrank.
- Attach a clevis to the threaded end of the wire.

34. INSTALL THE NYLON HORNS

- Correctly position the horns on the ailerons with the clevis still attached.
- Cut the sheeting just enough so the horn rests on the plywood horn plate.
- Attach the horns to the plates with the #2 x 3/8 screws. Drill pilot holes (1/16") first.
- Attach the clevis to the horn. The aileron should be in the neutral position. Adjust the clevis as necessary.

35. CUSTOM CUT AND GLUE ALL CAP STRIPS TO THE WING TOP AND BOTTOM

- Use the 1/16 x 1/4 x 36 balsa stock and cut the cap strips to fit.
- Glue the cap strips in place between the leading edge sheeting and the trailing edge sheeting over the last five ribs on each side of the wing.

36. GLUE ON THE 3/32" WING TIPS

- Center the wing tips on the centerline of the tip ribs from the leading edge to the trailing edge.
- Glue in place.

BOTTOM WING D (CONFIGURATION 3)

This wing is swept with no dihedral and is built flat in one piece.

1. PREPARE THE MAIN SPARS, REAR SPARS, LEADING EDGE AND TRAILING EDGE (49)

- Lay the plans on a flat work surface and cover them with waxed paper.
- Use a small saw and cut all the angles needed to build the 3/8 shaped leading edge, the 1/4 x 1/4 main spars, the 1/8 x 1/4 rear spars and the tapered trailing edge. Be sure to position the leading edge properly as it has a top and a bottom.
- Construct each individual part by gluing the pieces together over the plans. Make both sets of spars now (top and bottom).
- Cut the spars to length; they end at the middle of the outer R1 ribs.

2. PIN THE 1/4 SQUARE BALSA SHIMS TO THE PLAN

- The front shim is located at the rear of the leading edge.
- The rear shim is between the rear spar and the trailing edge of the ribs. See the plan for exact location; the solid rectangles are the shim locations.

3. PREPARE THE WING RIBS

- Separate two R7, four R3, two R8, two R9, six R6 and four R1 ribs from the die cut sheet. (You will have an extra R3 rib which you will not use.) You will not use the R4, R5 ribs and the S2 parts. They are used in Wing B that you are not building.
- Glue two R1 ribs together. Make two sets.
- Glue two R7 ribs together. Add 1/16" balsa to the leading edge of the R7 ribs to make them the same length as the other ribs. (R7 ribs are also used in Wing B which has spar ties.)

4. PIN THE BOTTOM 1/4 x 1/4 BALSA MAIN SPAR TO THE PLAN

5. POSITION AND GLUE ALL THE RIBS, INCLUDING THE DOUBLE RIBS, TO THE MAIN SPAR (50)

- Make sure the ribs are 90 degrees to the spar and work surface. Pin the ribs to the rear shim and main spar in their correct positions. Use The 1/4 ply hold down as a spacer to help you position rib R3 that glues next to R7. Note that the ribs are semisymmetrical. Make sure you get them all oriented correctly. Use the rib drawings the plans to help you identify "up" from "down" on each rib.
- Glue the ribs to the bottom main spar after making certain that the spar is fully seated in the spar notch of each rib.

6. GLUE THE TOP MAIN SPAR AND TOP AND BOTTOM REAR SPAR TO THE RIBS

- Slide the bottom rear spar under the ribs. Glue this spar on first. Make sure the ribs stay in alignment when you glue the spars in place.
- Glue the other two spars in place.

7. GLUE ON THE 3/8 PREPARED LEADING EDGE

- Place waxed paper over the shim and under the leading edge and slide the shim in place under the leading edge.
- Glue the leading edge to the ribs.

8. GLUE THE TRAILING EDGE TO THE RIBS (51)

Notice that the angles are not the same on the trailing edge stock. The 90 degree angle glues toward the bottom of the rib.

- Position and glue the trailing edge to the ribs.

9. ATTACH THE NYLON BELLCRANK TO THE BED; GLUE THE 1/8 PLY AILERON BELLCRANK BED INTO THE WING (52)

- Drill holes in the bed and attach the bellcrank and bushing to the bottom of the bed with a 4-40 bolt and hex nut. Use instant glue on the hex nut to keep the assembly from coming loose. Cut off the excess bolt length close to the nut.
- Glue the bellcrank and bed assemblies in place in the slots in ribs R8 and R9.

10. GLUE IN THE HARDWOOD HOLD DOWN BLOCKS AT THE FRONT OF THE WING BEHIND THE LEADING EDGE (53)

- Position the 1/4 ply hold down blocks between ribs R7 and R3 on each side of R7. Glue these blocks to the ribs and the leading edge.

11. ADD THE FILLER ABOVE THE FRONT HOLD DOWN BLOCK

- Glue in the filler blocks.
- Sand the filler blocks to the rib shape when the glue is dry.

12. GLUE IN THE TAPERED REAR HARDWOOD HOLD DOWN BLOCK (54)

- Glue these blocks to R3, R7 and the trailing edge.

13. ADD THE 1/16 X 2-1/2 BALSA TOP LEADING EDGE SHEETING

- Butt glue the sheeting together at the center of the wing after cutting it to fit.

14. GLUE ON THE TOP TRAILING EDGE SHEETING (55)

- This 1/16 x 2-1/2 sheeting is cut to fit at the center of the wing. Glue the sheeting in place.
- Note the small piece of sheeting that glues at the rear edge of the trailing edge sheeting. Glue this sheeting in place also.

15. TURN THE WING OVER AND ADD THE BOTTOM FILLER BLOCK

- Reshim the wing at the rear spar location after you turn it over.
- Glue the filler to the bottom of the front wing hold down block. Sand the filler to the rib shape.

16. GLUE ON THE BOTTOM LEADING EDGE SHEETING

- Trim pieces of 1/16 x 2-1/2 x 24 to fit.
- Glue the sheeting in place.

17. GLUE IN SMALL RIBS R3B AND R3C INTO THE AILERONS AND R3A INTO THE WING CENTER SECTION

- Glue two R3B and two R3C ribs into each aileron. Leave 1/32" of space between the R3B ribs and the rib next to it. Note the angle of the R3C ribs. Use the ply horn bed as a guide to placement.
- Glue two R3A ribs onto the center section side of the outboard ribs R3.

18. GLUE THE AILERON HORN BED INTO THE AILERON (56)

- Glue this 1/8" ply piece onto the two R3C ribs.
- Custom fit so the bed is even with the bottom of the ribs.

19. MARK THE CUT LOCATION ON THE TOP TRAILING EDGE SHEETING OF THE AILERONS (57)

- Using a hobby knife, mark through the sheeting from the bottom side at the slanted die cut lines on each rib. This gives you the cut line position when you cut out the ailerons. Do NOT cut along this line now. Only mark its position at each rib.

20. GLUE ON THE BOTTOM TRAILING EDGE SHEETING

- Cut pieces of 1/16 x 2-1/2 x 24 to fit.
- Glue in place.
- Note the small piece of sheeting that glues at the rear of the bottom trailing edge sheeting. Glue this sheeting in place also.

21. CUT THE STRIP OF BOTTOM TRAILING EDGE SHEETING AWAY FROM THE WING BETWEEN THE REAR SPAR AND THE FRONT OF THE AILERON (58)

- Mark the rear of the 1/8 x 1/4 rear spar on the bottom trailing edge sheeting.
- Mark the front of the aileron on the bottom trailing edge sheeting. This line is about 7/16" back from the rear spar line.
- Cut through only the sheeting along these lines. Use a metal straight edge to guide your cuts.
- Cut this strip of sheeting between the two long cuts at each end. Remove

the strip of sheeting. Cut the bottom sheeting at both ends of the aileron on both panels.

22. CUT THROUGH THE RIBS ALONG THE DIE CUT LINES (59)

Cut along the die cut lines on the ends of ribs R8, R9 and R6.

23. TURN THE WING OVER AND CUT THROUGH THE TOP TRAILING EDGE SHEETING AT THE FRONT OF THE AILERONS; CUT THROUGH THE TRAILING EDGE (60, 61, 62)

Draw a line along the cuts you made earlier.

Cut through the top trailing edge sheeting along this line using a straight edge to guide you.

Cut through the sheeting at both ends of this cut you just made and continue it rearward to the trailing edge of the aileron.

Cut through the trailing edge of the ailerons. Remove the ailerons.

24. GLUE IN THE 1/4 X 1/4 Balsa FILLERS IN THE AILERONS AT EACH HINGE LOCATION (63)

Glue the pieces in place at each of the four hinge locations in each aileron.

25. SAND THE AILERON LEADING EDGE AND REAR SPAR AREA (64)

Sand the front of the sheeting pieces even with the front of the ribs. Be very careful when you sand to keep the front of the ailerons straight.

Cut away the rest of the rib material and sheeting behind the rear spars. Sand the rib ends even with the back edge of the spars.

26. ADD THE REAR SPAR CAP AND AILERON CAP; FINAL SAND THE AILERONS (65)

Use 1/8 x 7/8 x 24 balsa and cut pieces to fit at the rear of the spars and at the front of the ailerons.

Lay the ailerons on flat surface. Pin the wing to a flat surface. Glue the four caps in place.

Sand the caps so they are flush with the sheeting. Sand the top of the aileron caps to a small "V" shape as shown on the plan in the "Bellcrank to Aileron Linkage" drawing. Sand the ends of the ailerons and the TE also.

27. GLUE IN THE 1/16 PLY SERVO BED (66, 67)

Cut away rib material in the servo bed location. Work from the top side of the wing.

Glue in S3 at the rear of the servo bed.

Glue shear web at the front of the servo well.

Use your servo as a guide for placement of the servo bed. Place the servo so the wheel or arm lines up with the pushrod holes in ribs R3. Make provisions for attaching the servo to a servo tray if you want to mount the servo in this manner. If you use a tray, mount the tray to the servo bed, then glue in the bed. Otherwise, the servo can be attached to the bed via hardwood blocks screwed to the bed. Glue in the bed.

28. through 41 See steps 28 through 41 under "BOTTOM WING B" as they are the same for this wing"D".

FINAL ASSEMBLY

1. ALIGN THE FUSELAGE TO THE WORK SURFACE

- The line that runs along the top of the fuselage side to just in front of the stabilizer, the Fuselage Reference Line, should be lined up parallel to the work surface. Place the fuselage upside down in a Robart Super Stand or similar set up to hold the fuselage up off the work surface. Measure from the Fuselage Reference Line to the work surface at several places along the line. These measurements should all be the same. Clamp or tape the fuselage in this position. (Measurement A should equal A in the drawing below and on your model.) Measure on both sides of the model and from the stab leading edge to the work surface on each side. ($A'=A'$)

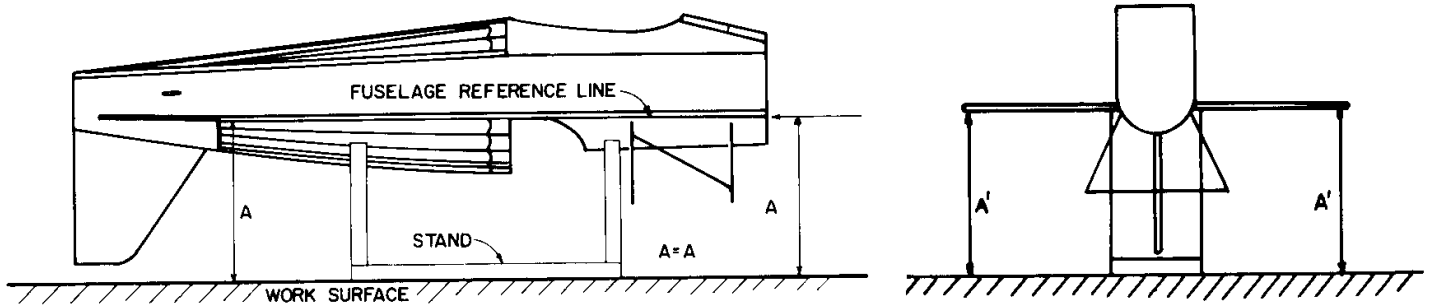

2. ALIGN THE BOTTOM WING TO THE FUSELAGE

- Lay the bottom wing in the wing saddle.
- Center the wing from side to side in the saddle. The distance from the fuselage side to the wing tip on each side should be the same. ($B=B$)
- Measure from each wing tip to each stab tip. These distances should be the same. ($C=C$)

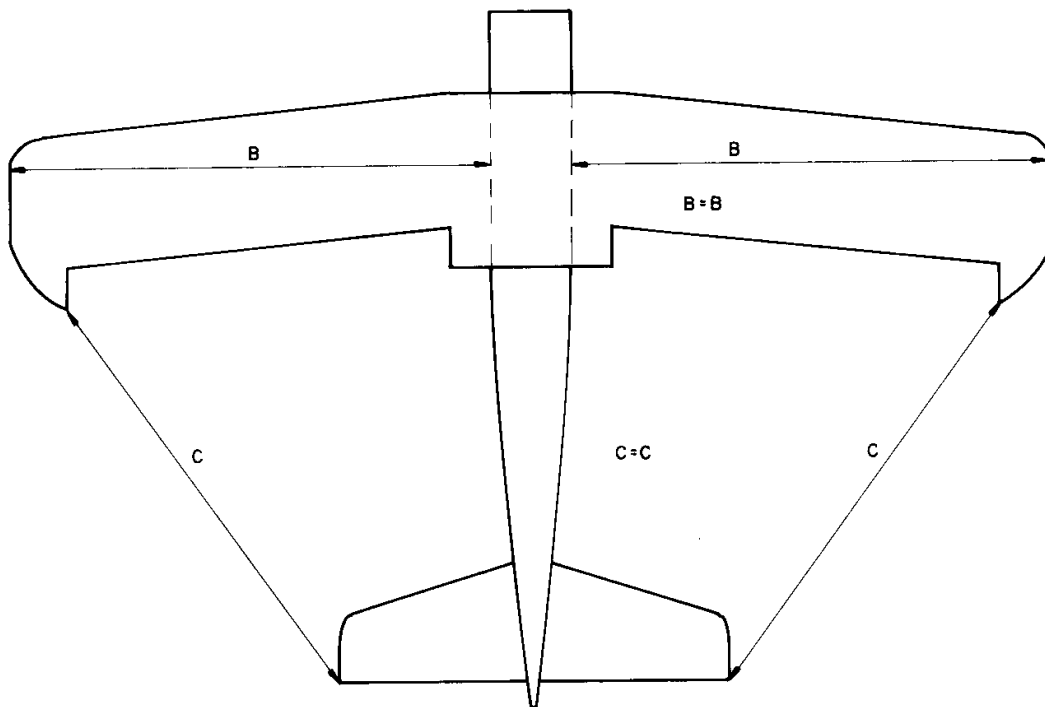

- Wing tip to work surface distance should be the same on both sides. ($D=D$)
- The bottom wing has 0 degrees incidence. This means the leading edge to work surface distance is the same as the trailing edge to work surface distance. ($E=E$)

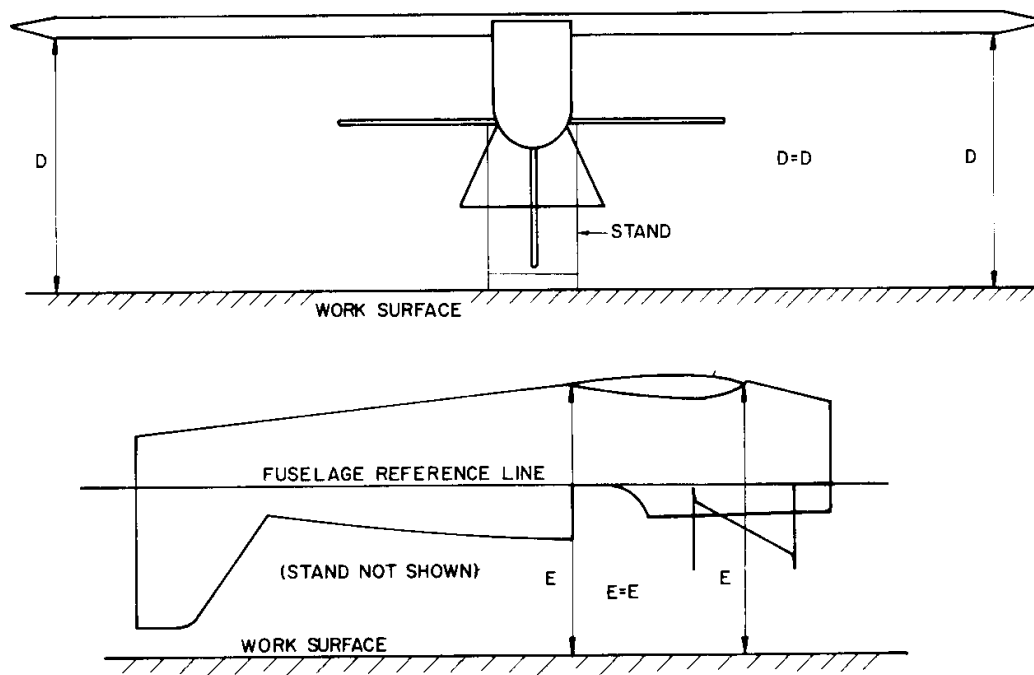

- Mark the position of the wing on the fuselage so you can easily place the wing in position again.

3. INSTALL THE WING BOLTS

- With the wing aligned to the fuselage, drill 3/16" pilot holes through the balsa fillers, plywood hold down plate in the wing and through the plywood plate in the fuselage. Drill two holes at the front and two holes at the rear. The rear holes are at an angle so the bolt head rests flat on the hold down piece.
- Remove the wing. Redrill the holes in the wing for 1/4-20 bolt clearance with a 1/4" drill bit. Counterbore the holes in the wing so the nylon bolt heads rest flat on the plywood plates in the front and flat on the hardwood hold downs in the rear.
- Tap the holes in the fuselage plates with a 1/4-20 tap.
- Trial fit the wing to the fuselage with the bolts. Cut the wing bolts off to shorten them. Leave the wing in place for now.

4. ATTACH THE TOP WING TO THE FUSELAGE (72)

- Turn the fuselage over. With the bottom wing attached to the fuselage, position the fuselage so the Fuselage Reference Line is parallel to the work surface and so is the bottom wing ($G=G$ in the drawing on page 35).
- The top wing has one degree of negative incidence in relation to the bottom

wing and Fuselage Reference Line. Place the top wing on the cabanes and line up the top wing to the fuselage and bottom wing making the same measurements you did with the bottom wing:

- Side to side
- Wing tip to stab tip
- Wing tip to work surface; top wing tip to bottom wing tip at trailing edge ($F=F$)
- Leading edge to Fuselage Reference Line should be about $1/32$ " less than the trailing edge to Fuselage Reference Line

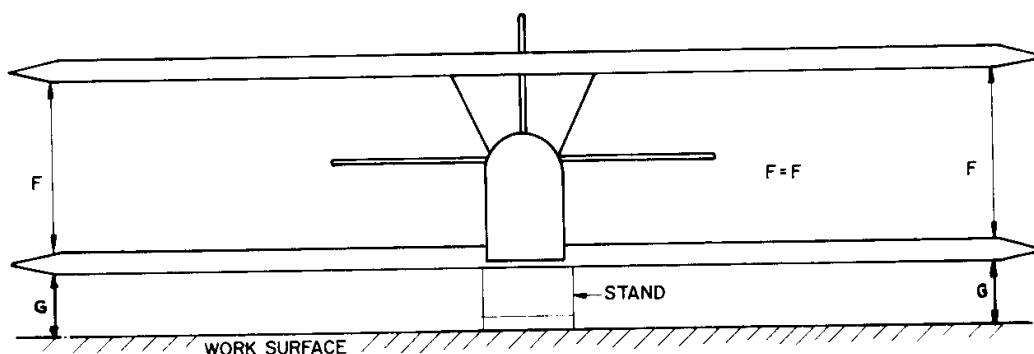

- Adjust the parts as necessary to arrive at the appropriate alignment. Mark the wing position in relation to the cabanes.
- Fill the slots in the cabanes blocks with silicone rubber and put car wax or similar material on the cabane wires. Immediately place the wing back on the cabanes. Remove the excess silicone that may ooze out of the slot. This silicone that you added makes a good seat for the wires and cuts down on vibration. Keep the wing aligned overnight until the silicone dries.
- Use the supplied metal cabane wire plates and mark the hole positions on the cabane blocks. Drill pilot holes ($5/32$ "); tap the holes with a 10-24 tap. Be careful not to drill all the way through the wing!
- Trial fit the top wing to the cabanes using the 10-24 nylon bolts. Remove both wings.

5. FUELPROOF THE ENGINE AREA

- Use epoxy or polyester resin and coat the front of the firewall, the front of former L and the inside of the cowl. This will help keep fuel from penetrating into the wood.

6. INSTALL THE FUEL TANK

- Feed extra long fuel lines through the holes in the front of former G/L. Place the fuel lines on the tank behind the firewall. Pull the tank into position by grasping the fuel lines in front of the firewall and pulling the tank forward.
- Brace the tank into position with scrap plywood and cushion the tank with foam rubber.
- Plug the fuel lines with screws to keep the lines clean until you attach the lines to the engine later.

7. OPTIONAL INTERPLANE STRUT CONSTRUCTION (73)

You may want to install interplane struts as shown on the red and white Super Aeromaster on the box label (Interplane struts connect the wings out near the wing tips). Here's how we did it:

Get the following parts:

12	Goldberg	#275	90 degree mounting brackets
12	Dubro	#190	1/16" threaded ball links
6	Dubro	#172	2-56 12" threaded rods
2	K & S	#1102	3/8" x 35" streamlined tube cut into six pieces of 11-1/2" each

Cut eight scrap plywood pieces about 3/8" x 1" and 1/8" thick. Cut out areas in the wing sheeting 3/8" x 1" and 1/16" down into the rib below the sheeting at the third rib location as shown on the plan by the solid rectangles. Cut the tops of the bottom wing and the bottom of the top wing.

Glue the plywood to the appropriate ribs. The ply pieces should be flush with the top of the sheeting and cap strips.

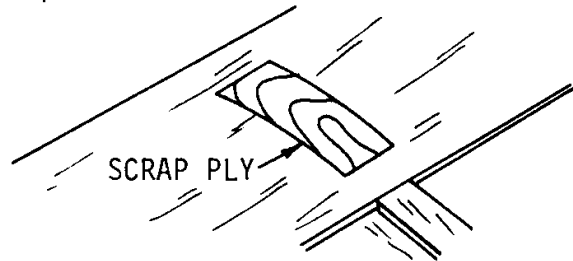
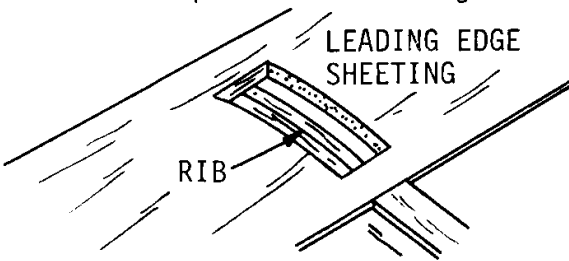

Drill a 1/16" hole in the non-hole side of the 90 degree brackets for ball link clearance.

Attach the ball to the bracket at the hole you drilled. The ball faces away from the bend in the bracket.

Attach the twelve brackets to the plywood blocks on top of the ribs with the screws that came with the brackets.

Measure between the ball links on the wings to determine the length of the wire and tube. (The wings should be attached to the fuselage.)

Cut streamlined tube and threaded wire to length. The wire should be longer than the tube to allow for the socket to be attached to the threads on the rod. Solder the brass coupler to the non-threaded end of the rod. Insert the wire into the tube. Thread a nylon socket onto both ends of the wire. Attach the tube/wire assembly, now called struts, to the ball links starting at the bottom ball.

Construct the other five struts and attach them to check the fit.

Remove the struts to be painted later when you paint the cowl and/or wheel pants.

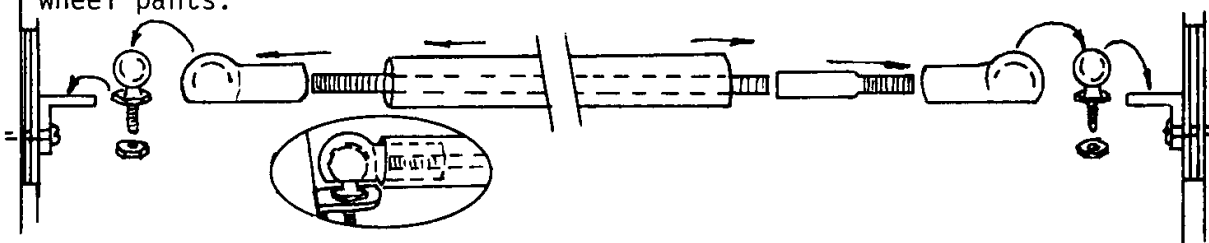

8. ADD THE OPTIONAL CABANE CROSS BRACE WIRES

- Use the stiffer wire provided and wrap and solder the cross braces as shown on the plans. Wrap the wire at least four times around the cabanes before you solder.

9. FINAL SAND ALL PARTS OF THE MODEL

- Use fine grit sandpaper and give the model a final sanding. Fill any "dings" in the wood with wood filler and sand smooth. Sand any glue joints and contours shown on the plan such as the curved edges of the bottom blocks below the firewall. The smoother you can get the wood on the fuselage and wings, the better your model will look after you cover it.
- Clean off the balsa dust with a tack rag or similar material. Wipe the model clean.

10. COVER THE MODEL WITH HEAT SHRINK COVERING

- Cut pieces slightly over size and attach the covering to the model. Be extremely careful when you trim the covering so you don't cut into the model itself and weaken the wood causing a structural failure. Use striping tape and/or trim covering to create your trim scheme or copy either one on the box label.

11. MOUNT THE ENGINE MOUNT AND ENGINE/MUFFLER (4 CYCLE ENGINE SHOULD BE SIDE-MOUNTED AND THE 2 CYCLE SHOULD BE MOUNTED INVERTED) (74, 75)

- Drill and tap holes in the engine mount for engine mount screws (not supplied). We suggest you use 6-32 bolts or 6-32 self tapping screws to attach the engine to the mount.
- Install the engine mount to the firewall or engine box.
- Attach the muffler to the engine. Note: On our two cycle prototypes, we used a Tatone #11314 Inverted Manifold Muffler. You could also use a Tatone Side Exhaust Manifold (#11354) or a Tatone Down Exhaust Manifold (#11334). Attach the engine to the mount with bolts or screws.

12. MODIFY THE COWL TO FIT OVER YOUR ENGINE (76)

- Attempt to install the cowl over the engine. Cut away any areas on the cowl for engine clearance. A Dremel tool and sanding drum are good tools to use for this job.
- Install the cowl to check your work. You should also cut any access holes in the cowl for carburetor adjustments etc.

13. PERMANENTLY INSTALL ALL CONTROL SURFACES

- Glue the hinges into the elevator and stabilizer.
- Use epoxy and glue the hinges into the hinge slots in the rudder. Drill a hole for tailwheel tiller arm. Glue these hinges into the fin and glue the tiller arm into the rudder.

- Glue hinges into the ailerons and wings.
- Check the glue bond at each hinge position to make sure the hinges are glued securely.

14. ATTACH THE MAIN GEAR (77)

- Place the gear in the slots in the landing gear block. The 5/32" wire goes in the rear slot and the 1/8" gear brace goes in the front slot.
- Place the metal hold down straps in position over the wire gear. Mark the hole locations on the plywood landing gear plate.
- Drill small pilot holes (1/32" or so) for the #2 x 3/8 screws provided at the marks you made.
- Fasten the gear to the fuselage using the screws and metal plates.
- Cover the wire gear with heat shrink covering and/or balsa if desired.

15. FINISH OFF CABIN AREA

- Use your imagination and finish the cockpit area. For instance you could add flooring just above the 3/16" fuse sides. Attach a pilot to this floor. Add an instrument panel and you're all set.
- Paint or cover all exposed areas so they won't show through the canopy to be added later.

16. ASSEMBLE THE WHEEL PANTS

- Cut and trim the wheel pant halves on their parting lines on the inside of the pant halves. You can score this line with an X-Acto knife and break on this line or simply cut on the line with a knife.
- Sand the edges of the wheel pant smooth. An easy way to do this is to lay your sandpaper down on a flat surface and move the pants over the sandpaper. This way you are assured of a straight, flat edge when you finish.
- Cut a starter hole in one half of each pant in the area of the wheel opening to make it easier to cut out the opening after the halves are glued together. Cut a starter hole at the join line.
- Using cyanoacrylate (instant glue), join the two pant halves together. Note that there is a right and a left half to the wheel pant. Make sure you have a good fit before you glue the two halves together.
- When the halves are joined, sand lightly along the join line on the outside of the pant to get a smooth appearance.
- Use your wheel and measure and mark the area to be cut out of the pant for the wheel opening. Cut out this area.

- Find the tape locations on the inside of the pant in the drawing below. Use 60-100 coarse sandpaper and sand the areas where you will put the tape.

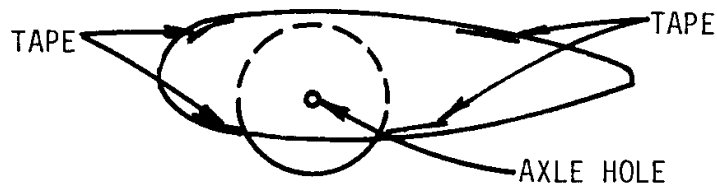

- Reinforce the inside of the wheel pants with fiberglass tape. Cut the tape into 1" squares. You should have 8 pieces of tape when you finish cutting. Use 5 minute epoxy and a piece of tape at each of the places you sanded. You can do this two different ways: 1- Put the epoxy on the inside of the wheel pant and then put the tape at the epoxied places on the inside of the pant. Force the glue into the tape with your fingers. 2- Put the tape on waxed paper, put epoxy on the tape and then put the tape in place on the inside of the pant. Press the tape in well and then remove the waxed paper. In either case, let the tape hang out of the wheel opening. Cut the excess off when the epoxy is dry.

17. TEMPORARILY MOUNT THE WHEEL PANTS

- Mark the position of the axle hole on the inner side of each wheel pant.
- Drill a clearance hole at this location for your gear wire or axle bolt.
- Mark the position of the brass plate on the gear. Do this by temporarily placing the wheel pant on the gear. Position the pant so it does not touch the ground and is level or in the correct position for your model. Mark the position of the brass plate on the gear and on the outside of the pant. Remove the wheel pant.
- Solder the brass plate to the gear using Sta-Brite silver solder. Position and solder the other brass plate in the same manner.
- Position the 1/8" plywood plate on the inside of the wheel pant opposite the brass plate on the gear. Temporarily put the wheel pant back on the gear to find this position. The ply plate is used as a backup plate for the brass plate so do a good job of lining these two plates up.
- When you have the correct positions for the ply plates, use 5 minute epoxy and glue them to the inside of the wheel pants. Let the ply plates dry.
- Drill the axle hole through the ply plates in the pants.
- Using the brass plate as a guide, drill two pilot holes through the wheel pants and the ply back up plate for the #2 x 3/8 screws.
- Trial fit the wheel pant assembly to the gear by attaching screws provided,

wheels and 5/32 wheel collars (not provided) to hold the wheels to the gear. If all is in the correct position, remove the assembly from the gear.

18. PAINT THE WHEEL PANTS

- Sand lightly with wet/dry 320-400 sandpaper but use it dry.
- Use K&B primer or automotive primer and prime the wheel pants.
- Sand the primer after it is dry. You need only to sand the primer lightly.
- Put on the final coat of paint. Spraying works the best for the final coat but brushing the paint will give you good results also.

19. MOUNT THE WHEELS AND WHEEL PANTS (78)

- Place the painted wheel pants, wheel collars (5/32"-not provided) and wheels in position on the axle.
- Gently bend the axles to give the wheel a slight amount of toe-in. This will let the model roll straighter down the runway.
- Tighten the wheel collar screws when the pants and wheel are in the correct position.

20. PAINT THE COWL; INSTALL THE COWL, PROP AND SAFETY NUT (79)

- Sand the cowl again if necessary to give it a good finish.
- Use K&B primer or similar primer and prime the cowl. Let the primer dry.
- Sand the primer.
- Spray or brush on the final coat of paint.
- When the paint is dry, install the cowl, propeller and AMA safety nut. Follow the engine manufacturer's recommendations on propeller size.

21. INSTALL WING SEATING TAPE

- Place wing seating tape, sticky side down, onto the wing saddle area. This protects the wing and gives it a good cushion to rest against. This tape also helps to keep dirt and fuel out of the radio compartment.

22. INSTALL THE CANOPY (80)

- Trim the canopy on the cut line with a modeler's knife.
- Sand the edges smooth with fine grit sandpaper.
- Wash the canopy with soap and water and wipe it dry.
- You can tint the canopy if you wish. Use Rit dye and follow the instructions included in the box of dye. Take the canopy out of the dye solution when you have the color you want. The longer you leave the canopy in the dye the darker it gets.

- Use cyanoacrylate glue sparingly and glue the canopy to the fuselage.
- Add trim tape or other material around the bottom of the canopy.

23. BALANCE THE MODEL

Note: The Center of Gravity (C.G.) shown on the plan is for Configuration #1. The C.G. for Configuration #2 is 3/4" in front of the rear cabane strut. The C.G. for Configuration #3 is 3/8" in front of the rear cabane strut.

- Temporarily place all pushrods and radio equipment in position in the fuselage and wing by taping it in place at the places shown on the plan as a starting point.
- Mount the wings on the fuselage. The fuel tank should be empty.
- Balance the model on the ends of your fingertips on the bottom of the top wing where the center of gravity is for your particular configuration.
- Move the radio equipment away from the heavy end of the model until the model balances from the front to back at the C.G.
- The model should also balance from side to side at the center of the fuselage. Move radio equipment accordingly.
- It may become necessary to add weight to the nose or tail to get the model to balance correctly. Try not to do this if possible as extra weight affects performance slightly.

24. INSTALL THE SERVOS, BATTERY AND RECEIVER IN THE FUSELAGE (81)

- Follow the radio manufacturer's recommendations wherever possible.
- Mount the throttle, elevator and rudder servos in the tray that came with your radio. Mount the tray to hardwood or plywood servo rails (not Supplied). If no tray came with your radio, mount the servos directly to the servo rails as shown on the plan. Cushion the servos with rubber grommets between the rail and servo mounting tabs.
- Wrap the battery and receiver in foam rubber and place in the fuselage.
- The on/off switch should be mounted through a hole in the fuselage so it can be accessed from the outside.
- The charging jack may also be positioned through the fuselage side for easy access.

25. INSTALL THE AILERON SERVO (82)

- Install the aileron servo in the tray that came with the radio.
- Fasten the tray to the servo bed.
- If you did not get a tray with your radio, install the servo directly to the servo bed via hardwood rails made from scrap.

26. INSTALL THE AILERON LINKAGE AND CONTROL HORNS

- Attach the "bellcrank linkage" wire to the servo output arm or wheel.
- Attach bellcrank to aileron linkage with a 90 degree bend in the wire. Position the control horns to the aileron horn beds with the #2 x 3/8 screws. Attach the other end of the linkage to the control horns with an adjustable clevis.

27. INSTALL THE RADIO LINKAGE, CLEVISES AND CONTROL HORNS INTO THE FUSELAGE (83)

- Place the throttle cable inside its tube. Attach one end to the throttle arm on the engine. Make at least one end adjustable.
- Place the threaded wire rods inside the tubes, with the threads toward the rear and outside of fuse through the exit holes.
- Attach clevises to the threaded ends of the rods.
- Attach the other ends of the rods to the rudder and elevator servos, using a 90 degree bend and cutting the wires and tubes to fit.
- Attach control horns to the rudder and elevator.
- Attach the clevises to the control horns.

28. ADJUST ALL THE THROWS OF THE CONTROL SURFACES

- Set up all the linkages so the control surfaces and servos are in neutral.
- Adjust the clevises so the following throws are set up:

Ailerons- 1/2" up and 1/2" down
 Elevator- 3/4" up and 3/4" down
 Rudder- 1-1/4" left and 1-1/4" right

- Adjust the throttle throw so the throttle arm has its full range of movement.

29. CHARGE BATTERIES AND DO A RANGE CHECK

- Make sure the batteries are fully charged.
- Run the antenna out the fuselage and attach it to the fin top. Do not cut the antenna wire!
- Follow the radio manufacturer's instructions and do a range check at your flying field before attempting to fly.

30. FLYING TIPS

Note: The following is a direct quote from the original designer, Lou Andrews:

"Assuming that the model is correctly balanced, warp free and all servos and surfaces in neutral and everything checked out, read on:

The Aeromaster has exceptionally fine ground handling characteristics and does not easily ground loop. The Aeromaster is a very docile and easy to fly model that can also be tossed around and made to perform almost violently if desired. It has a very clean and semi-fast rate of flight speed and the speed is rather constant during maneuvers. The Aeromaster also has a fantastic high glide ratio both in a dead stick approach or low motor approach and has to be slowed down by inducing angle of attack as in a three point landing approach. The Aeromaster can be brought up much higher on angle of attack than just mentioned without stalling out if desired. Two wheel landings can be had after first slowing model down with angle of attack and then raising the tail just before the touchdown. If you have enough room such as at big contests, long, low angle of attack approaches can be made with either two or three point landings. The model is extremely stable during landing maneuvers and also very responsive to all control surfaces except rudder. The rudder is most effective during maneuvers such as wing overs, spins, knife edge flight, etc. but a little slower on most other maneuvers and actually you don't ever use the rudder except for these maneuvers or to steer the model on the ground...Ailerons are used more than anything for most maneuvers combined with elevator and motor control...On the Aeromaster, the rudder will only yaw the model and not bank it...Because the Aeromaster is proportioned like the large bi-planes, torque from the motor has to be considered especially during takeoffs and landings. If you gun the motor from a standstill or when coming in very slowly the airplane will tend to bank to the left. It therefore is very important to slowly advance the motor speed on takeoff and landing. The best and most controllable takeoffs are to slowly roll the model on three wheels, raise the tail, advance the throttle slowly to full and away you go. From here on its all yours. Good flying."

We at Great Planes hope you have enjoyed building your Super Aeromaster.

Good Luck and Great Flying!

SUPER AEROMASTER PARTS LIST

<u>PART NUMBER</u>	<u>QUANTITY</u>	<u>DESCRIPTION</u>
AAROA21	1	Plastic Cowl/Wheel Pants
AAROF37	1	3-Ply 1/16 DC Cabane Brace/Dihedral Brace
AAROF45	1	3-Ply 1/8 DC Cowl Front, Bellcrank Bed
AAROF46	1	3-Ply DC Cowl Rear, Bellcrank Bed
AAROF50	1	Balsa 1/8 x 3-1/4 x 36 Cowl Sheeting
AAROP06	1	Plan-Wing A,B,C and D (2 sides)
AAROP08	1	Plan-Fuselage
AAROP09	1	Photo Sheet
AAROP10	1	Instruction Book
AAROW13	1	Balsa 1/16 x 3 x 24 Shear Web
BAL049	2	Balsa 3/16 x 3/16 x 36 Cowl Stringer
BAL126	5	Balsa 1/16 x 1/4 x 36 Cap Strips
CANPY016	1	Canopy
MM60LU	1	Motor Mount
WBNT105	2	Cabane Struts
WIRES01	1	Wire 1/16 x 36 Bellcrank Linkage
<u>AAROA11</u>	<u>1</u>	<u>DIE CUT PARTS</u>
AAROF38	2	Balsa 3/32 Formers A,D and F, Wing Rib 3C
AAROF39	2	Balsa 3/32 Formers B,C,E,S1 and S2
AAROF40	2	Balsa 3/32 Formers H,J, and Cowl Sheeting
AAROF48	1	Balsa 3/32 Formers F,G,K,L, and Stab Fairing
AAROW17	1	Balsa 3/32 Ribs 8,9 and S3
AAROW18	2	Balsa 3/32 Ribs 2,3A and 7
AAROW28	2	Balsa 3/32 Rib 3B,4,5 and 6
AAROW29	5	Balsa 3/32 Ribs 1 and 3
<u>AAROA12</u>	<u>1</u>	<u>FUSELAGE PARTS</u>
AAROF30	2	Balsa Shaped 3/16 Fuselage Side
AAROF31	2	Balsa Shaped 5/16 Box-Lok Fuselage Side
<u>AAROA13</u>	<u>1</u>	<u>FUSELAGE PARTS</u>
AAROR06	1	Balsa Shaped 1/4 Rudder
AAROS01	2	Balsa Shaped 1/4 Elevator
AAROW30	4	Balsa Shaped 3/32 Wing Tips
<u>AAROA14</u>	<u>1</u>	<u>FUSELAGE PARTS</u>
AAROR03	1	Balsa 1/4 x 2-15/16 x 6-9/16 Fin Rear
AAROR07	1	Balsa Shaped 1/4 Fin Center
AAROR08	1	Balsa Shaped 1/4 Fin Front
AAROS02	1	Balsa 1/4 x 3 x 18 Stab Rear
AAROS03	1	Balsa Shaped 1/4 Stab Front

<u>AAROA15</u>	<u>1</u>	<u>FUSELAGE AND WING PARTS</u>
AAROF11	4	Plywood Shaped 3/16 x 1-3/16 Cabane Strut Support Block
AAROF12	1	Plywood Shaped 3/8 Landing Gear Plate
AAROF20	2	Plywood Shaped 3/16 x 4-5/8 Cabane Strut Support Block
AAROF34	4	Plywood 1/8 x 1 x 2-7/8 Cabane Lock Plate
AAROF35	1	Plywood Shaped 1/4 Firewall
AAROF41	2	Plywood 1/4 x 7/8 x 3 Hold Down Plate in Fuselage
AAROF42	1	Plywood 1/4 x 2-1/2 x 2-1/2 Engine Box Front
AAROF43	2	Plywood 1/4 x 3/4 x 2 Engine Box Side
AAROF44	2	Plywood 1/4 x 3/4 x 2-1/2 Engine Box top and Bottom
AAROF47	2	Plywood 1/8 x 3/4 x 3/4 Cowl Block
AAROW20	2	Plywood 1/4 x 3/4 x 1-13/16 Front Hold Down-Bottom Wing
AAROW21	2	Plywood 1/8 x 3/4 x 2-3/4 Aileron Horn Bed
AAROW23	1	Plywood 1/16 x 2-1/2 x 3-7/8 Aileron Servo Bed

<u>AAROA16</u>	<u>1</u>	<u>HARDWARE BAG</u>
GLTP001	1	Fiberglass Tape 1 x 8
WBNT009	1	Wire 3/32 Tailwheel Assembly
WBNT040	1	Wire 5/32 Main Landing Gear
WBNT041	1	Wire 1/8 Main Landing Gear Brace
WBNT045	2	Wire 3/32 Elevator Tie
WBNT106	2	Wire 3/32 Main Landing Gear Brace
WBNT107	2	Wire 3/32 Cabane Brace
WIREF12	11	Wire for Wrapping Solder Joints
WIRE014	1	Wire-optional Cabane Cross Brace

<u>AAROM01</u>	<u>1</u>	<u>HARDWARE PARTS BAG</u>
BRSH001	2	Brass Bushings for Bellcrank
METAL007	2	Brass Plate-Wheel Pants
METAL010	4	Metal Cabane Hold Down Straps
NUTS002	2	4-40 Hex Nuts
NUTS003	8	6-32 Blind Nuts
NYLON01	2	Nylon Bellcrank
NYLON03	4	Nylon Control Horn
NYLON09	2	Nylon Hinges
NYLON13	4	Nylon 1/4-20 x 2 Wing Bolt
NYLON22	8	Nylon 10-24 x 5/8 Cabane Bolt
NYLON36	4	Nylon Landing Gear Straps
PLY3013	2	Plywood 1/8 x 1/2 x 1 Wheel Pant Screw Back Plate
SCRW002	4	2-56 x 5/8 Screw
SCRW003	2	4-40 x 1 Screw
SCRW024	16	#2 x 3/8 Screw
SCRW032	4	6-32 x 1/2 Sockethead Screw
SCRW033	4	6-32 x 3/4 Screw

<u>AAROA17</u>	<u>1</u>	<u>WING BED PARTS</u>
AAROF49	1	Balsa Shaped 1/2 Wing Bed-Right
AAROF53	1	Balsa Shaped 1/2 Wing Bed-Left

37. ADD FILLER PIECES TO WING TIP, SAND TO SHAPE AND SHEET TOP AND BOTTOM OF THE WING TIPS

- Fit and glue 1/4 square and 1/8 x 1/4 tip spar extensions to the tips.
- Glue on 1/4 square balsa filler pieces at the leading edge and 1/8 x 1/4 balsa filler pieces between the spar extensions on both the top and bottom of the wing tips.
- Sand the fillers to shape as shown on the plan.
- Sheet the tips with 1/16 x 2-1/2 sheeting only at the leading and trailing edges. The center of the wing tip is left open.

38. FINAL SAND THE WING

- Round the leading edge slightly as shown on the plan.
- Sand all parts of the wing including all glue joints. Fill in any "dings" with balsa filler and sand smooth.

39. GLASS THE CENTER SECTIONS OF BOTH WINGS (70)

- Cut a piece of 4 to 6 ounce glass cloth about 4" wide and lay it on the wing bottom center section.
- Use polyester resin, epoxy or CA and attach the glass cloth to the wing. Let the resin or glue dry thoroughly.
- Cut another piece of cloth and glass the top center section.
- Sand the glass when it is dry. Sand to a smooth finish.
- Apply a second coat of resin. Let it dry. Repeat the above for the other wing.

IMPORTANT: Omitting this step will result in a wing failure during flight and result in a crash. Make sure you glass both wings.

40. MARK AND CUT THE HINGE SLOTS FOR THE AILERONS

- Mark the hinge positions on the wing spar caps and on the aileron caps. Note that the ailerons are hinged at the top.
- Cut the hinge slots with an X-Acto knife or hinge slotting tool. The slots should be cut at the angles shown.
- Trial fit the hinges into the ailerons and wing. Do not glue the hinges until you cover the wing later. Final sand the ends of the ailerons and aileron openings so there is about 1/32" clearance at both ends.

41. CUT THE TOP CENTER SECTION SHEETING OUT OVER THE SERVO WELL (71)

- Cut the sheeting out over the well. Sand the edges smooth.

AAROA18	1	FUSELAGE AND WING PARTS
AAROR01	1	Balsa 1/4 x 3/4 x 20-3/4 Rudder, Fin, Stab Tip Stock
AAROW07	1	Balsa Shaped 3/8 x 24 Leading Edge (Set of 5)
AAROW08	4	Balsa Shaped 5/32 x 24 Trailing Edge
AAROW15	4	Balsa 1/8 x 7/8 x 24 Aileron and Spar Cap
AAROA19	1	STRINGERS/SPARS
AAROF06	30	Balsa 1/8 x 1/4 x 24 Stringers
AAROW06	17	Balsa 1/4 x 1/4 x 24 Spars/Stringers
AAROA20	1	SHEETING
AAROW05	25	Balsa 1/16 x 2-1/2 x 23-7/8 Wing Sheeting
AAROA22	1	FUSELAGE AND WING PARTS
AAROF18	2	Balsa 1/4 x 5/8 x 3-3/8 Rear Box-Lok Tie
AAROF36	2	Balsa Shaped 3/8 x 2 x 2 Bottom Block
ARROW10	1	Balsa Shaped 5/32 x 8-1/8 Trailing Edge Center
AAROW19	2	Hardwood Tapered 3/8 Rear Hold Down-Bottom Wing
AAROW22	2	Balsa 1/4 x 9/16 x 3-1/2 Wing Cap-Top Wing
AAROW25	1	Balsa 1/4 x 9/16 x 8 Wing Cap-Top Wing
AAROW26	2	Hardwood 7/16 x 3/4 x 7-15/16 Cabane Block-Top Wing
AAROW27	4	Balsa 3/8 Leading Edge Filler-Bottom Wing

IMPORTANT NOTICE

To further strengthen the joint between the hold-down plate and the fuselage sides, cut two "U-Shaped" 1/8" ply plates from scrap plywood. Use epoxy and glue these small plates to the fuse sides and to the under side of the hold-downs. Also glue 3/4" x 3/4" balsa triangle stock to the under side of the hold-downs and to the ply plates.

