

Spirit

INSTRUCTION BOOK

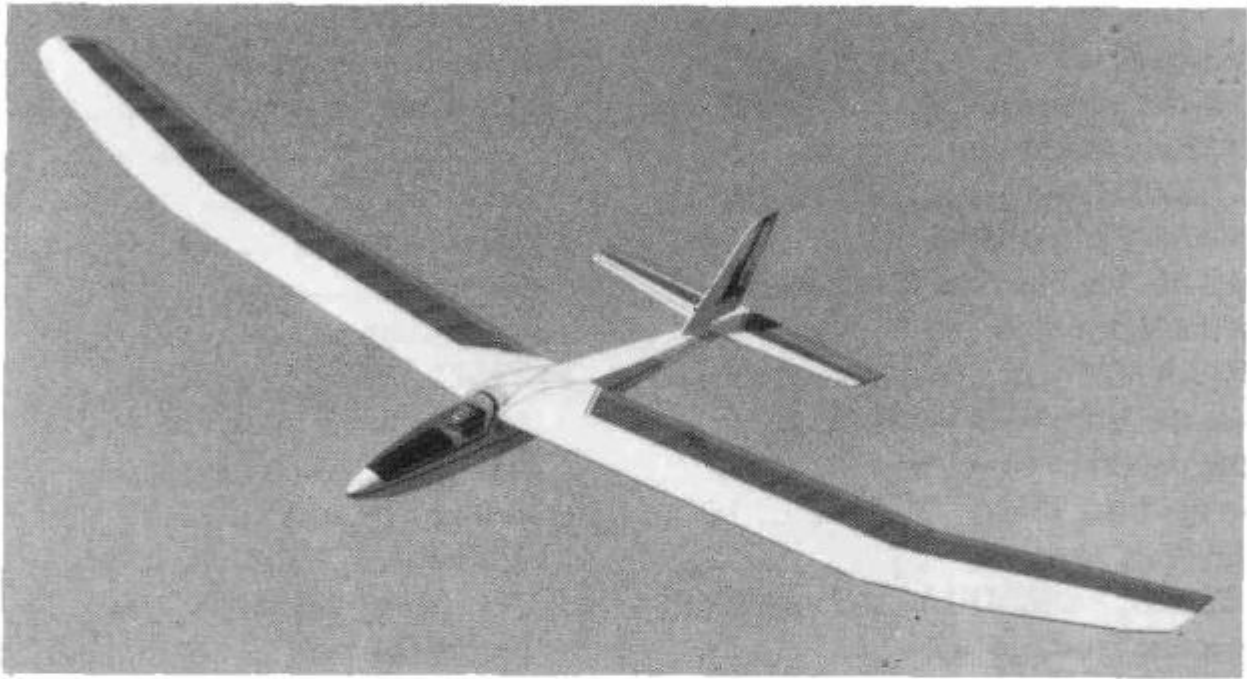

PLEASE READ THROUGH THIS INSTRUCTION BOOKLET IN ITS ENTIRETY BEFORE BEGINNING ASSEMBLY. IT CONTAINS IMPORTANT INSTRUCTIONS AND WARNINGS CONCERNING THE ASSEMBLY AND USE OF THIS MODEL.

WARNING! THIS IS NOT A TOY!

This R/C kit and the model you will build is not a toy! It is capable of serious bodily harm and property damage. **IT IS YOUR RESPONSIBILITY AND YOURS ALONE** - to build this kit correctly, properly install all R/C components and to test the model and fly it **only** with experienced, competent help in accordance with all safety standards and common sense as set down in the Academy of Model Aeronautics Safety Code. It is suggested that you join the AMA to become properly insured before you attempt to fly this model. **IF YOU ARE JUST STARTING R/C MODELING, CONSULT YOUR LOCAL HOBBY SHOP OR WRITE TO THE ACADEMY OF MODEL AERONAUTICS TO FIND AN EXPERIENCED INSTRUCTOR IN YOUR AREA.**

Academy of Model Aeronautics
5151 Memorial Drive
Muncie, IN 47302 1-800-435-9262



P.O. BOX 788 URBANA, ILLINOIS 61801 217398-8970

TABLE OF CONTENTS

<p>INTRODUCTION 3</p> <p> Precautions 3</p> <p> Other Items Required 3</p> <p> Supplies and Tools Needed 3</p> <p> Die Patterns 4</p> <p> Abbreviations 5</p> <p> Types of Wood 5</p> <p> Decisions you must make now ... 5</p> <p> Get Ready to Build 5</p> <p>TAIL FEATHERS 6</p> <p> Build the Fin and Rudder 6</p> <p> Build the Stabilizer and Elevator . 7</p> <p> Cut the Hinge Slots 8</p> <p>WING ASSEMBLY 9</p> <p> Build the Inner Wing Panel 9</p> <p> Build the Outer Wing Panel 12</p> <p> Join the Wing Panels 14</p> <p> Final Wing Assembly 15</p> <p>FUSELAGE ASSEMBLY 19</p> <p> Assemble Fuselage Sides 19</p> <p> Frame-up the Fuselage 20</p> <p> Assemble the Canopy 23</p> <p>FINAL ASSEMBLY 25</p> <p> Balance the Airplane Laterally ... 25</p> <p> Final Sanding 25</p> <p> Covering.....25</p> <p> Checking for Warps 26</p> <p> Glue the Hinges 26</p> <p> Mount the Tail Surfaces 27</p> <p> Assemble Pushrods 27</p>	<p> Install Radio Gear 28</p> <p> Control Throws 29</p> <p> Install the Spoilers in the Wing ... 29</p> <p> Balance the Model 29</p> <p> Final Hookups and Checks 30</p> <p>PRE-FLIGHT 31</p> <p> Charge the Batteries 31</p> <p> Find a Safe Place to Fly 31</p> <p> Range Check Your Radio 31</p> <p> Install the Wings 31</p> <p>AMA Safety Code 31</p> <p> General 31</p> <p> Radio Control 31</p> <p>FLYING 32</p> <p> Trim Flights 32</p> <p> Your First Hi-Start Launch 32</p> <p> First Flights 33</p> <p>THERMAL FLYING 33</p> <p> Facts About Thermals 33</p> <p> Thermal Soaring 34</p> <p> Pointers for Contest Flying 35</p> <p>SLOPE SOARING 35</p> <p> Flying 35</p> <p> Slope Landings 36</p> <p>POWERED LAUNCHING 36</p> <p>BALLASTING 36</p> <p>BUILDING NOTES 36</p> <p>PARTS LIST 37</p> <p>CONTEST PRACTICE CHART .. 39</p> <p>2-VIEW DRAWING 40</p>
--	---

Please inspect all parts carefully before starting to build! If any parts are missing, broken or defective, or if you have any questions about building or flying this airplane, please call or write us at the address below and we will be glad to help. If you are calling for replacement parts, please look up the part numbers and the kit identification number (stamped on the end of the kit box) and have them ready when calling. Thank you.

Great Planes Model Mfg., Inc.

P.O. Box 788

Urbana, IL 61801 (217) 398-8970



P.O. BOX 788 URBANA, ILLINOIS 61801 217398-8970

INTRODUCTION

Congratulations! You are about to enter the exciting world of silent flight. Soaring offers a freedom that no other type of flying can offer! It is your knowledge and your SPIRIT'S flying abilities in a fight against gravity. With a little practice and some help from mother nature you will be able to defeat gravity and enjoy flights that can last for hours and cover many miles at incredible altitudes.

Thank you for purchasing the Great Planes **SPIRIT** sailplane. It has been designed to give you many hours of relaxing flying, and has also been engineered to provide a truly enjoyable building experience.

PRECAUTIONS

1. You must build the plane according to **the plans and instructions**. Do not alter or modify the model as doing so may result in an unsafe or un-flyable model. In a few cases the plans and instructions may differ slightly from the photos. In those instances you should assume the plans and written instructions are correct.

2. You must take time to **build** straight, true and strong.

3. You must use a proper R/C **radio** that is in first class condition.

4. You must properly install all R/C and other components so that the model operates properly on the ground and in the air.

5. You must **test** the operation of the model before the first and each successive flight to insure that all equipment is operating, and you must make certain that the model has remained structurally sound. Be sure to check the nylon clevises often, and replace if they show signs of wear.

6. You must **fly** the model **only with the competent help** of a well experienced R/C pilot if you are not already an experienced and knowledgeable R/C pilot at this time.

Note: We, as the kit manufacturer, can provide you with a top quality kit and great instructions, but ultimately the quality and "fly-ability" of your finished model depends on how **you** build it; therefore, we cannot in any way guarantee the performance of your completed model, and no representations are expressed or implied as to the performance or safety of your completed model.

Remember: Take your time and follow directions to end up with a well-built model that is straight and true.

OTHER ITEMS REQUIRED

Radio having at least 2 channels (a third channel is required for optional spoilers)

Iron-on Covering Material (2 rolls)

Latex Foam Rubber Padding (1/4" **thick**)

#64 Rubber Bands

Hi-start or other Launching Device

BB's or Lead Shot for Balancing

The Optional Spoilers Also Require:

1 - 3/16" x 1/4" x 36" Balsa Stick

2 - 30" Lengths of Braided Fishing Line

2 - 30" Lengths of 1/8" Plastic Tubing

The Optional Bolt-On Wing Also Requires:

1 - Small Sheet of 1/4" Birch Plywood

1 - Small Piece of 1/16" Birch Plywood

SUPPLIES AND TOOLS NEEDED

2 oz. Thin CA Adhesive

2 oz. Medium or Thick CA Adhesive

2.5 oz. 5-Minute Epoxy

Hand or Electric Drill

Drill Bits: 1/16", 5/64", 1/8", 9/64" (13/64" **and** 17/64" for Wing Bolt Option)

Sealing Iron

Heat Gun

Razor Saw

Hobby Knife, #11 Blades

Pliers

Screw Drivers

T-Pins

Assorted Rubber Bands

Straightedge

Masking Tape

Cellophane Tape

Vinyl Tape

Sandpaper (coarse, medium, fine grit)*

T-Bar Sanding Block (or similar)

Waxed Paper

Lightweight Balsa Filler

1/4-20 Tap, Tap Wrench (for bolt on wing option)

Dremel Moto Tool or Similar (optional)

***NOTE:** On our workbench, we have four 11" T-Bar sanders, equipped with #50, #80, #100 and #150-grit sandpaper. This setup is all that is required for almost any sanding task. We also keep some #320-grit wet-or-dry sandpaper handy for finish sanding before covering.

DIE PATTERNS

Do not punch out die-cut parts until ready to use!

SPRTF01

2 PER KIT



BALSA 3/32" X 3-1/4" X 38-1/2"

SPRTF06

1 PER KIT



BALSA 1/8" X 3" X 9-7/8"

SPRTF02

2 PER KIT

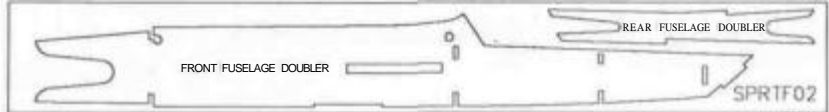

BALSA 3/32" X 3-1/4" X 24"

SPRTW07

2 PER KIT

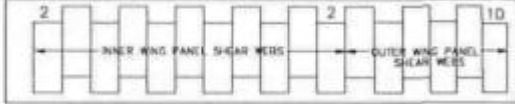

BALSA 1/16" X 3" X 15"

SPRTF03

1 PER KIT



PLY 1/8" X 3" X 19"

SPRTF05

1 PER KIT



PLY 1/8" X 4" X 11-7/8"

SPRTF04

1 PER KIT

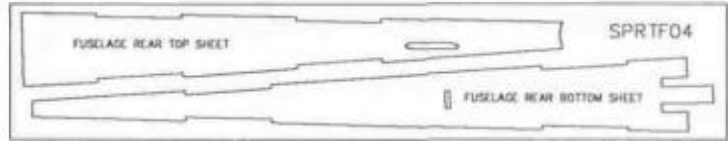

BALSA 3/32" X 4" X 21"

SPRTS01

1 PER KIT

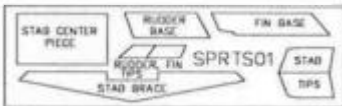

BALSA 3/16" x 3" x 9-7/8"

SPRTW02

2 PER KIT



BALSA 1/16" X 3" X 23-7/8"

SPRTW03

2 PER KIT



BALSA 1/16" X 3" X 23-7/8"

SPRTW08

1 PER KIT

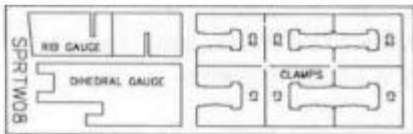

PLY 1/8" X 3-7/8" X 11-7/8"

SPRTW01

1 PER KIT



BALSA 1/8" X 3" X 23-7/8"

SPRTW05

1 PER KIT

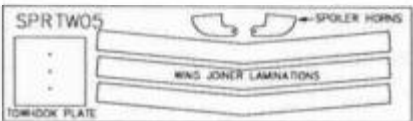

PLY 1/16" X 3-3/8" X 11-7/8"

SPRTW04

1 PER KIT

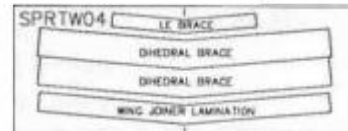

PLY 1/8" X 3-3/4" X 10-1/2"

SPRTW06

1 PER KIT



PLY 1/32" X 3-1/4" X 9-3/4"

COMMON ABBREVIATIONS USED IN THIS BOOK AND ON THE PLANS:

Elev	=	Elevator
Fuse	=	Fuselage
LE	=	Leading Edge (front)
Lt	=	Left
Ply	=	Plywood
Rt	=	Right
Stab	=	Stabilizer
TE	=	Trailing Edge (rear)
"	=	Inches

TYPES OF WOOD

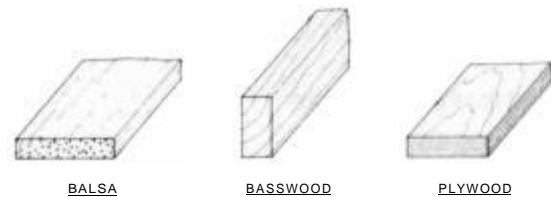

GET READY TO BUILD

NOTE: It will be helpful to build on a piece of "Celotex", or other semi-soft (and flat) surface, into which you may easily stick pins to firmly hold down the parts while building and to avoid warps.

DECISIONS YOU MUST MAKE NOW

WING CONFIGURATION

The SPIRIT kit has three different wing options: a two-piece rubber band on wing, a one-piece bolt on wing or a one-piece rubber band on wing. The two-piece wing is the easiest version to build and is recommended for beginners. Some experienced sailplane pilots may prefer the one-piece bolt on wing, but the large wing can present transportation problems in today's small cars. The one-piece rubber band wing would be the next best choice for beginners.

SPOILERS

The SPIRIT can be built either with or without spoilers. Spoilers act as airbrakes and make it easier for experienced pilots to precisely land on target during contests. They can also be helpful in losing altitude quickly. Due to the added complexity encountered when installing spoilers, they are NOT recommended for first time builders. If you are a beginner and may eventually want spoilers, install just the spoiler tubing now and the rest of the spoiler pans can be installed when you are ready.

1. Unroll the plan sheet. Re-roll the plan inside out and let it uncurl while you read through this instruction book. This will help the plan lay flat and get you acquainted with the building process. **NOTE: Because there are several options to consider when building the SPIRIT, you should read the instruction book through before building and then go back and cross off the steps you won't use to build your model.**

2. Remove all parts from the box. As you do, figure out the name of each part by comparing it with the plans and the parts list at the back of this book. Write the part **name** or **size** on each piece to avoid confusion later. Use the die-cut patterns shown on page 4 to identify the die-cut parts and mark them. If any of the die-cut parts are difficult to punch out during construction, do not force them! Instead, first cut around the parts with a hobby knife. After punching out the die-cut parts, use your T-Bar or sanding block to **lightly** sand the edges to remove any die-cutting irregularities.

INSTRUCTIONS IN BOXES LIKE THIS ARE VERY IMPORTANT AND SHOULD BE FOLLOWED CAREFULLY

"TAIL FEATHERS"

BUILD THE FIN AND RUDDER

You'll need the following parts:

SPRTS02	3/16" x 3/8" x 30" Balsa Stick
SPRTS03	1/8" x 3/16" x 30" Balsa Stick
SPRTS01	3/16" Die-Cut Tail Parts
SPRTF08	3/16" Balsa Triangle

D 1. Tape or pin the **plan** down to your flat work surface. Tape a piece of waxed paper over the fin and rudder portion of the plan (so you don't glue the parts to the plan).

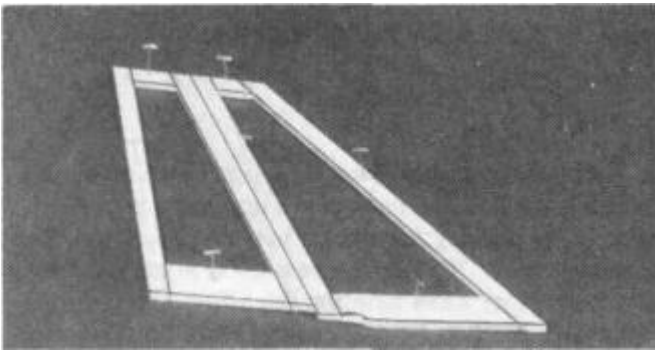

D 2. Using the plan as a guide, cut pieces of 3/16" x 3/8" balsa (from the 30" sticks, SPRTS02) to make the **Rudder and Fin Framework**. NOTE: Cut the Fin L.E., the Rudder L.E. and the Rudder T.E. from a single SPRTS02 (This will leave enough long pieces for the stab). Punch out the die-cut **Fin Tip, Rudder Tip, Fin Base and Rudder Base** from SPRTS01. Sand the edges if necessary and pin them in place on the plan and glue the parts together using thin CA glue. NOTE: **Do not glue the fin to the rudder!**

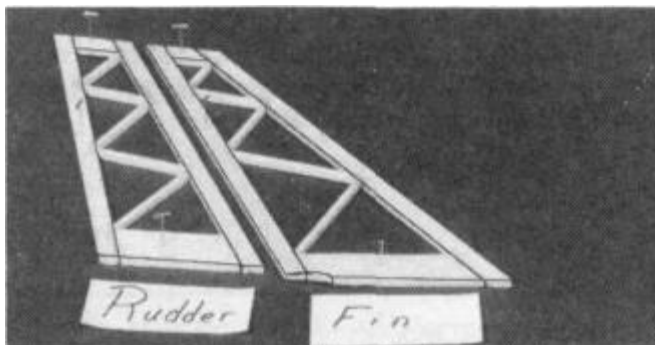

D 3. From the 1/8" x 3/16" x 30" sticks (SPRTS03), cut the diagonal "**ribs**" to fit between the rudder and fin framework, and glue them in place. NOTE: It is **not** necessary to get these ribs in the **exact** position shown on the plan.

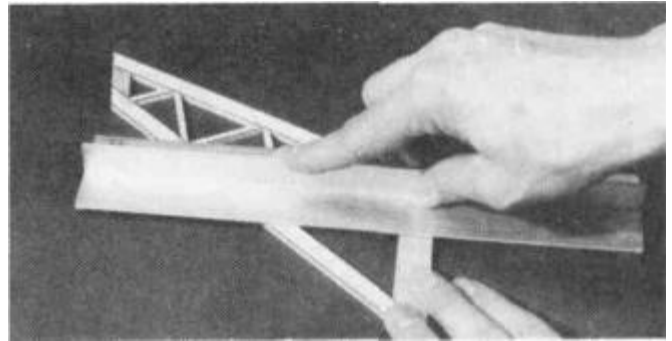

D 4. Remove the fin and rudder assemblies from the plan and examine them for any open or bad joints. Fill any gaps with thick CA, then use your sanding block with medium grit sandpaper to sand both sides of the framework smooth.

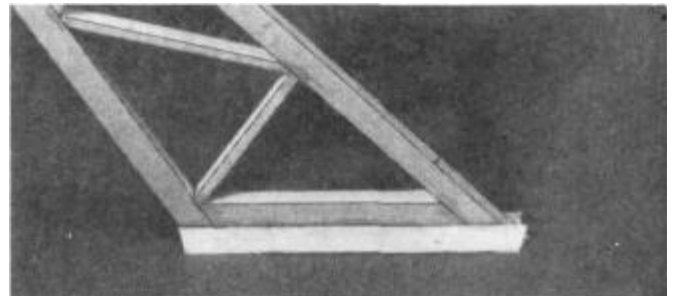

D 5. Cut two 4-1/8" lengths of 3/16" **Balsa Triangle** from SPRTF08 and glue them along the bottom of the fin. The bottom edges of the triangle should be flush with the bottom of the fin.

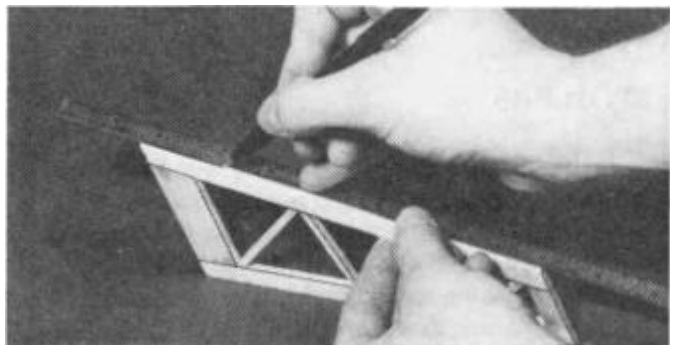

D 6. Carefully draw a **centerline** all around the edges of the rudder and fin (this will help to maintain symmetry when sanding).

D 7. Using a sanding block and **coarse** (50 or 80-grit) sandpaper, sand the leading edge of the rudder to the V-shape as shown on the plans (a small razor plane works great for initial shaping). Sand the three remaining edges to a smooth rounded shape. Sand the top and the leading edge of the fin to a nice rounded shape*. NOTE: **The trailing edge of the**

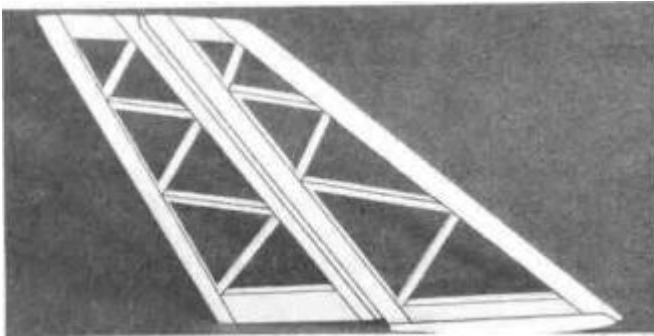
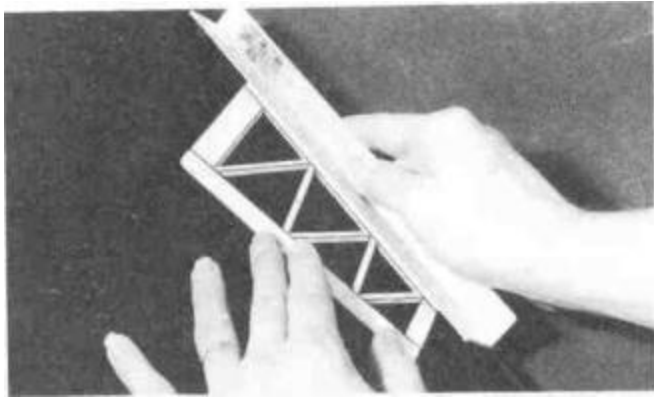

FIN must remain square, do not sand it! Sand the triangle stock to blend with the leading and trailing edges of the fin. Also, cut or sand the bottom of the triangle stock to match the contour of the 3/16" die-cut fin bottom.

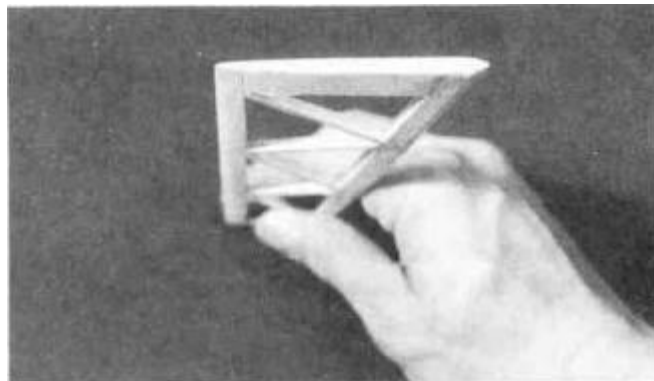

*** MAXIMUM PERFORMANCE TIP -** Sand both sides of the rudder to a taper as shown on the plans. This requires a little more work but will help to reduce drag and thus increase performance of the sailplane.

BUILD THE STABILIZER AND ELEVATOR

You'll need the following parts:

SPRTS02	3/16" x 3/8" x 30" Balsa Sticks
SPRTS03	1/8" x 3/16" x 30" Balsa Sticks
SPRTS01	3/16" Die-Cut Tail Parts
SPRTS04	Tapered Elevator

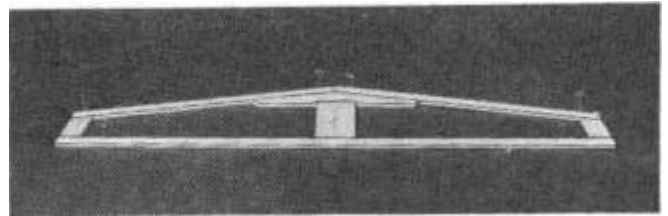

D 1. Tape waxed paper over the stabilizer drawing on the plan. In the same manner as the rudder, cut the 3/16" x 3/8" balsa pieces and using the die-cut Stab Tips, Stab Center and Stab Brace from SPRTS01, assemble the stab framework using thin CA glue.

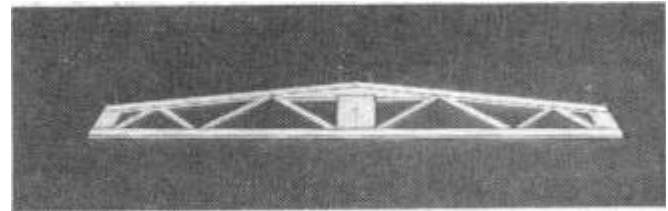

D 2. Cut the 1/8" x 3/16" "ribs" to length and glue them in place.

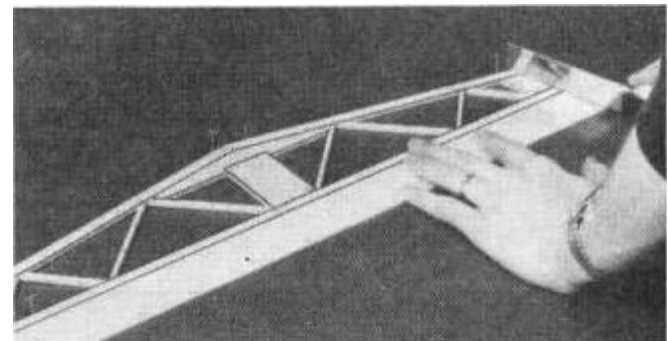

D 3. Pin or tape the elevator (SPRTS04) in place behind the stab and use your razor saw to cut the ends off to match the stab.

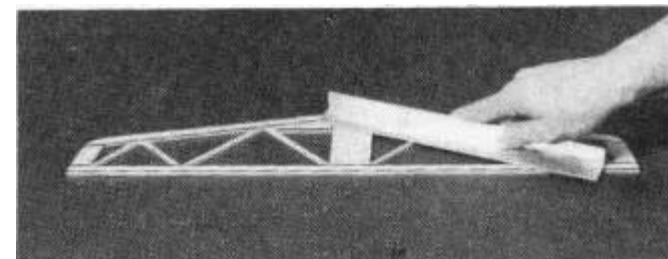

D 4. Remove the stab from the plan and examine it for any open or bad joints. Fill any gaps with thick CA, then use your sanding block with medium grit sandpaper to sand both sides smooth. Draw a centerline around the stab edges.

D 5. Tape the elevator to the stab using masking tape and sand the leading edge of the stab, the stab tips and the elevator tips to a smooth rounded shape. The tips of the elevator should blend in nicely with the stab lips.



D 6. Remove the elevator and draw a center line down its leading edge. Use your sanding block to sand the same V-shape as you did on the rudder. The trailing edge should also be sanded to a smooth rounded shape.

CUT THE HINGE SLOTS (Do not glue)

NOTE: One-piece molded polypropylene hinges are supplied in this kit. If you choose to use these hinges or the "pinned"-type hinges, you may cut the hinge slots at this time. However, if you choose to use the one-piece hinges that are paper covered for CA glue installation, you may wait until after covering before cutting the hinge slots.

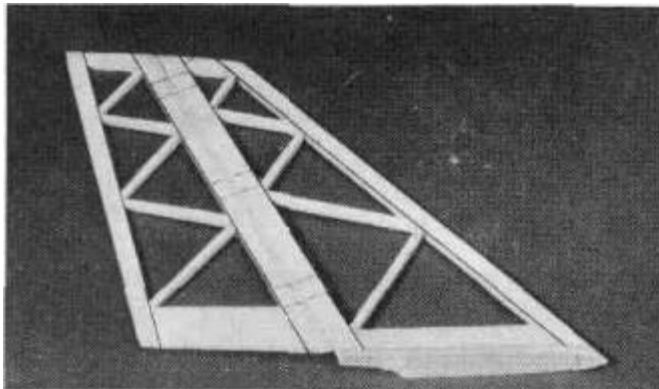

D 1. Lay the rudder and elevators on the plan and mark the **hinge** locations. Place the rudder against the fin TE and transfer the marks over to the fin. Place the elevator against the stab TE and transfer the marks over to the stab.

CAUTION!!!: You must use extreme care when cutting hinge slots with a hobby knife, to avoid cutting yourself! If the balsa part breaks while you are pushing on the knife, the blade could go into your hand before you know it! A good precaution is to wear leather gloves while performing the following steps.

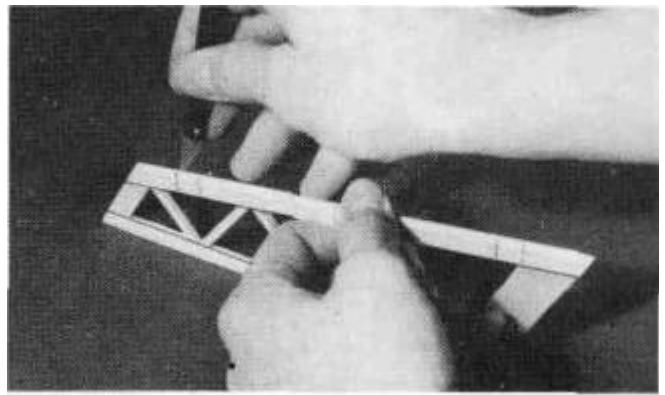

D 2. Draw accurate centerlines down the trailing edge of the stab and the fin. Cut the hinge slots **on these lines** using a hobby knife or a slotting fork and slotting hook. (The recommended hinge slotting technique is listed below).

A. Begin by carefully cutting a **very shallow slit** at the hinge location. This first cut is to establish your cut in the right place, so concentrate on staying on the centerline and **don't cut too deep!**

B. Make three or four more cuts in the same line, **going slightly deeper each time.** As you make these additional cuts, work on going straight into the wood. Continue this process while **"wiggling"** the knife handle forward and backward until the blade has reached the proper depth for the hinge.

C. Trial fit the hinge into the slot. If the hinge is difficult to push in, re-insert the knife and move it back and forth in the slot a few times to enlarge the slot.

D 3. IMPORTANT! Condition or "break-in" the hinges by folding them back and forth several times.

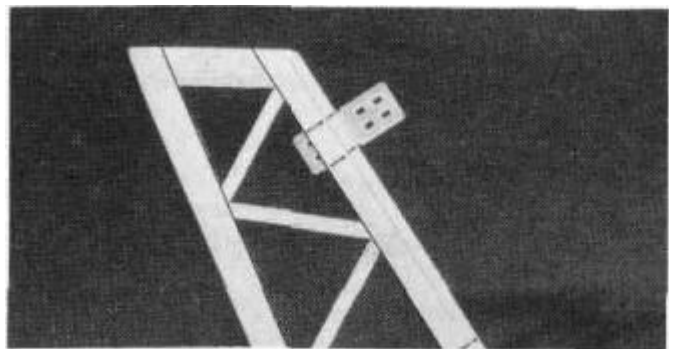

D 4. Insert the hinges into the slots and trial fit the rudder and elevator in place on the fin and stab. **Do not glue the hinges until after you have covered the model.**

WING ASSEMBLY

BUILD THE INNER WING PANELS

You'll need the following parts:

SPRTW01	1/8" Die-Cut Balsa Wing Ribs
SPRTW02	1/16" Die-Cut Balsa Wing Ribs, W2, W2S
SPRTW03	1/16" Die-Cut Balsa Wing Ribs, W2, W4-W10
SPRTW04	1/8" Die-Cut Plywood Dihedral Braces
SPRTW07	1/16" Die-Cut Balsa Shear Webs
SPRTW08	1/8" Die-Cut Plywood Clamps and Gauges
SPRTW10	Shaped Balsa Leading Edge
SPRTW11	Shaped, Notched Balsa Inner Trailing Edge
SPRTW13	1/8" x 5/16" x 23-1/2" Basswood Spars
SPRTW17	1/16" x 3" x 24" Balsa Wing Sheeting

NOTE: The wing is designed to be built as a two-piece wing; however, we also describe how to build a one-piece wing which can be either held on with rubber bands or 1/4 - 20 nylon wing bolts (not included).

D 1. Tape the plan to your flat work surface, and cover the wing drawing with waxed paper. **NOTE:** If your work space is limited, you may cut the wing drawings apart from the rest of the plans.

D 2. The Shaped Wing Leading Edges (SPRTW10) are fastened together by thin strips of balsa. Separate them by carefully cutting **between** the LE'S. Sand away the excess balsa that remains along the edges after cutting them apart, using a sanding block with 100-grit sandpaper.

D 3. Before using the 1/8" x 5/16" x 23-1/2" **Basswood Spars** (SPRTW13), examine them carefully for possible imperfections. Look for knots, soft spots, diagonal grain and any other imperfections. If possible, position each spar so the imperfections are on the outer half of the wing panel (toward the tip), where they will be least affected by high stress. If the spars are warped slightly, "balance them out" by installing the warped spars in opposite directions (see sketch).

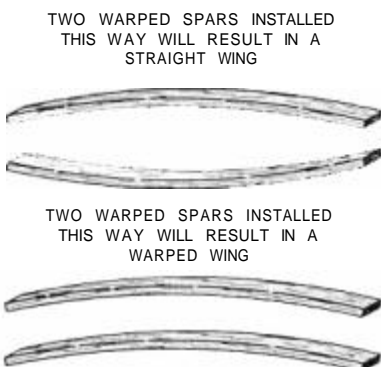

D 4. Carefully punch out all the die-cut 1/16" **Balsa W2 and W2S Wing Ribs**. Sand the edges **slightly** to remove any die-cutting irregularities.

NOTE: Follow step 5 below through step 7 on page 15 to build the LEFT wing panel, then repeat these steps to build the RIGHT wing panel.

DD 5. Pin one of the notched balsa **Inner Trailing Edges** (SPRTW11) to the plan lining up the notches in the TE with the notches on the the plan.

DD 6. Place one of the 1/8" x 5/16" x 23-1/2" Basswood Inner Spars (SPRTW13) on the wing plan and pin the spar down with crossed T-pins as shown in the following sketch. **NOTE:** The spars may be cut slightly oversize, the excess will be cut off later.



DD 7. Place the seven **W-2 ribs** (from SPRTW02 and SPRTW03) and the two **W-2S ribs** (from SPRTW02) on the spar in their approximate positions, work the ribs into the notches on the trailing edge but do not glue anything yet.

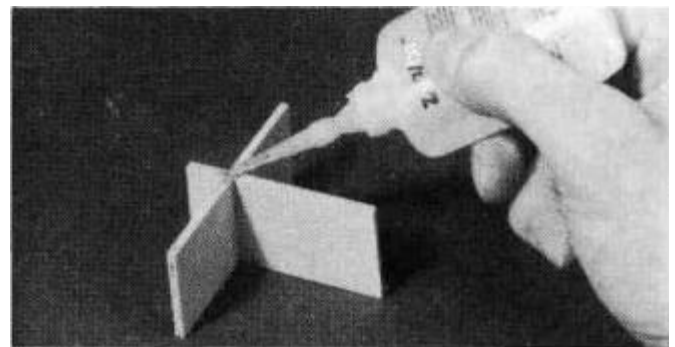

DD 8. Punch out the two **Rib Gauge Pieces** from the 1/8" die-cut plywood sheet (SPRTW08) and assemble them using CA. Notice that one end of the gauge is slanted at a 5 degree angle for positioning the end ribs. The other 3 ends are perpendicular and can be used to keep parts 90 degrees to the work surface.

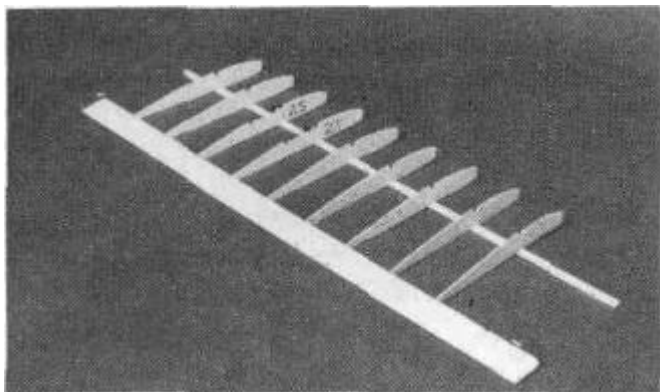

DD 9. Make sure the ribs are properly positioned according to the plans and glue them in place using thick CA at the spar joint and a drop of thin CA at the trailing edge joint. Use the square end of the rib gauge to keep the ribs perpendicular to the work surface. **NOTE: if you are installing spoilers, cut out the embossed area on the two W2S ribs and make sure you install these ribs in the proper locations.**

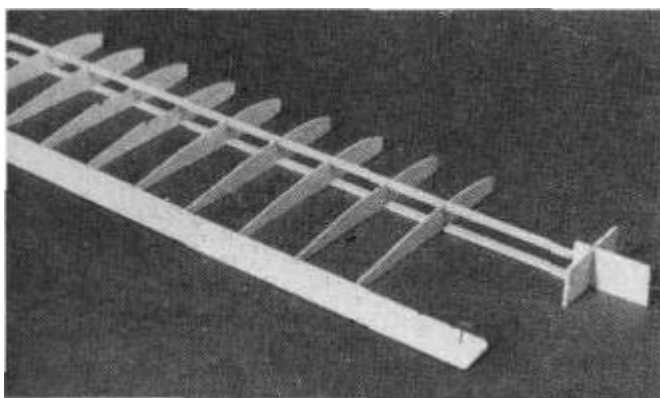

DD 10. Trial fit the top 1/8" x 5/16" x 23-1/2" Basswood **Inner Spar** (SPRTW13) into the notches in the ribs by carefully pushing the spar completely down into the notches. Make sure the top spar is lined up lengthwise with the bottom spar. Remove the spar and glue it in place by applying thick CA to the notches before the spar is put back in place.

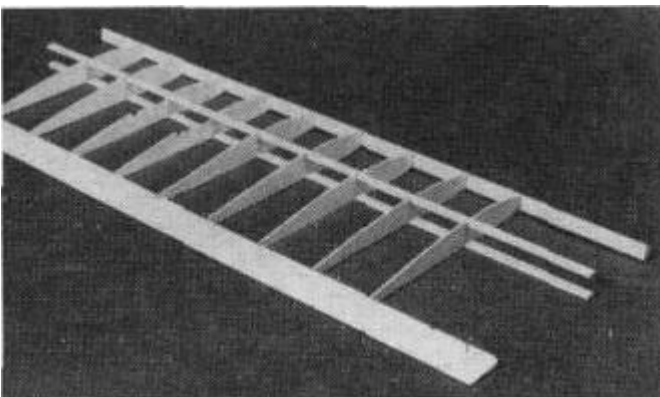

DD 11. Position a **Pre-shaped Leading Edge** (SPRTW10) in place over the plans. **NOTE: These leading**

edges are NOT symmetrical. Refer to one of the section views on the plans to determine which way they should be installed. Carefully hold the leading edge against one of the end W-2 ribs and note that it is wider than the front of the rib. This is because the 1/16" balsa leading edge top sheeting will be added later. Align the lower surface of the leading edge with the bottom of the rib and glue it in place with a drop of thin CA. Lift up the other end of the leading edge, align it with the bottom of the opposite end W-2 and glue it with a drop of thin CA. Go down the line and glue the remaining ribs to the leading edge one at a time so you can make sure they are aligned.

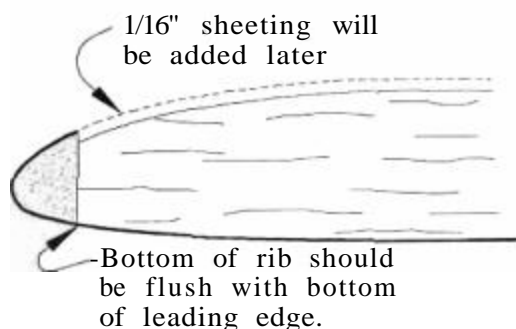

DD 12. Locate the **1/16" Balsa Die-Cut Shear Web Sheet** (SPRTW07) and notice that all of the shear webs are not the same. The webs between the number 2's are for use on the inner panel. The webs between the 2 and the 10 are for the outer panel and each one of these is a different size so keep them in the sheet until they are ready to be used. Punch out all of the "2" shear webs.

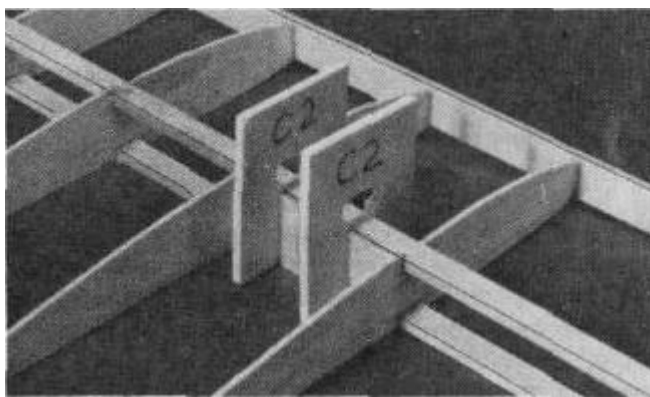

DD 13. Trial fit one of the webs in place between the first two W-2 ribs. You may have to sand it slightly to get it to fit. Glue the shear web in place on the back of the spars using thick CA. The webs should be centered (up and down) between the spars. It is important to do a good job of gluing these in place as they are responsible for most of the wing's strength. C-2 Clamps from the 1/8" Die-Cut Plywood Sheet SPRTW08 can be used to help hold the webs in place while the glue cures.

DD 14. Install the remaining balsa shear webs. Note that the webs are only installed between the ribs already glued in place. Three webs are also installed on the front of the spars

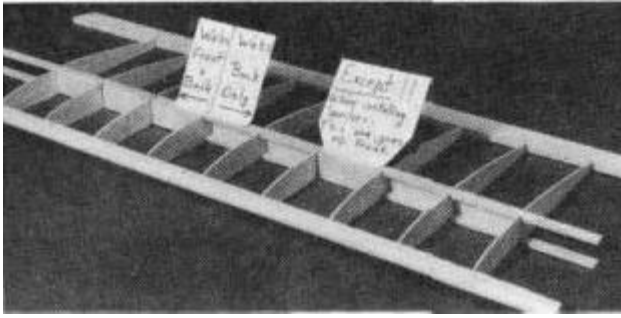

in the first three rib "bays". NOTE: if you are installing spoilers in the wing or may add them in the future, install the web between the two W2S ribs on the FRONT of the spars to make room for the spoiler horn.

IF YOU ARE BUILDING A ONE-PIECE WING, SKIP AHEAD TO "BUILD THE OUTER WING PANEL" ON PAGE 12. STEPS 15 THROUGH 22 ARE FOR A 2-PIECE WING ONLY.

DD 15. Locate the 1/8" die-cut sheet (SPRTW04) that contains the **Dihedral Braces**, the **Leading Edge Brace** and the **Wing Joiner Lamination**. Line a ruler up with the two embossed cut marks and draw a line across both of the dihedral braces.

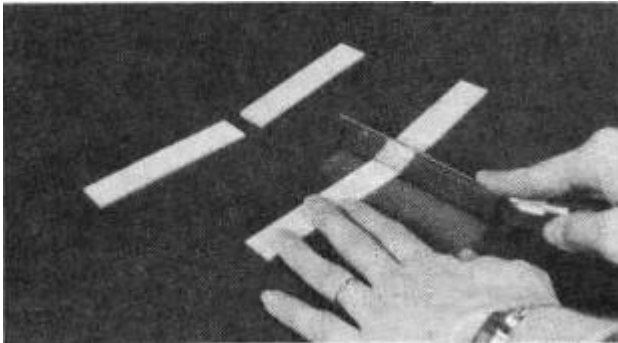

DD 16. Punch out the two dihedral braces and cut them in half with a razor saw along the lines you just drew. **Note: these braces are supplied in one piece for the bolt on wing option.** Also punch out the wing joiner lamination from that sheet and set it aside for the next step. The leading edge brace is not used in a two-piece wing.

DD 17. Punch out the three C1 clamps from the 1/8" die-cut plywood sheet (SPRTW08). Test fit two of the dihedral brace "halves" to the "root" (inner) end of the inner panel spars. One brace should be installed on the front of the spars and the other on the back. The edge that you cut with the razor saw should be near the end of the spars and it should be placed so that it slants in at the top (towards the middle of the wing). Use the C1 clamps to hold the braces in place and test fit the wing joiner lamination into the box formed. This "box" will be referred to as the "joiner box". The wing joiner lamination is used to make sure the spars remain the correct distance apart. (See photo at the top of the next column.)

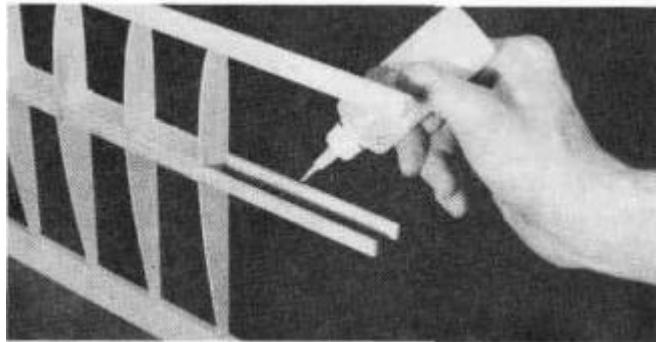
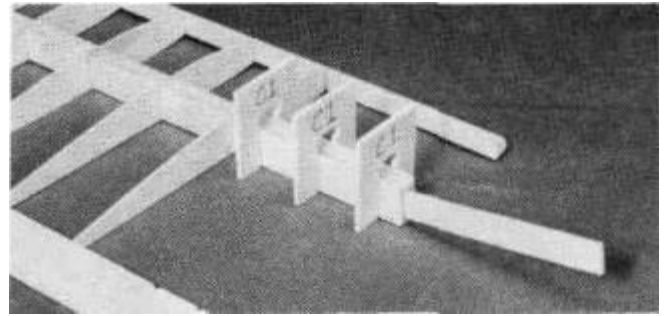

DD 18. Remove the clamps and apply a bead of epoxy along the spar edges (thick CA will also work but be very careful to get things aligned properly before the glue cures). Install the braces and hold in place with the C1 clamps. A good glue joint is important here but be careful not to get any excess glue inside the box formed by these braces or the wing joiner will not fit inside. Also test the size of the joiner box with the joiner lamination while the glue is curing.

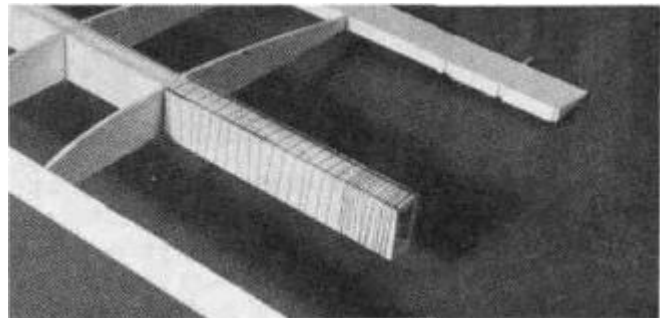

DD 19. Tightly wrap the joiner box with a strong thin thread and then soak it with thin C/A. This will add a lot of strength to the joiner box. Do not overlap the thread or allow it to build up too thick.

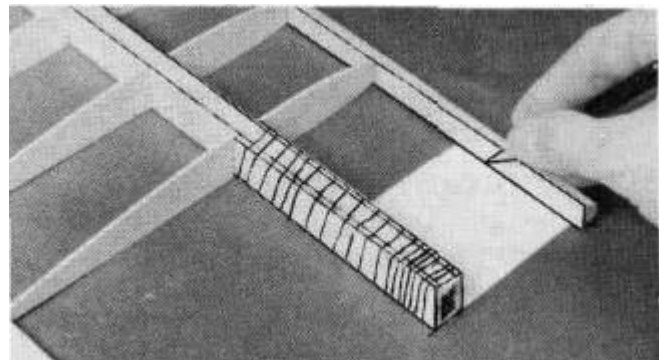

DD 20. Locate one of the 1/16" x 3" x 30" **Balsa Sheets** (SPRTW 17) and cut it into 6 pieces 2-3/8" long. Slide one of the sheets in place in front of the joiner box and trim to fit. Use another sheet to shim up the front edge (See sketch nextpage). **Glue** it in place with thick CA.

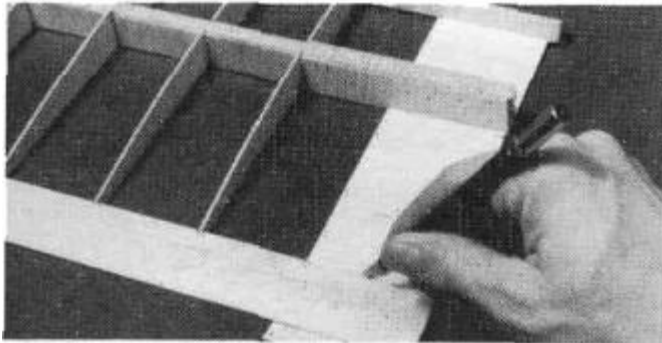
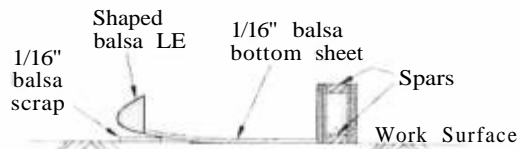

DD 20. Glue another piece to the rear of the joiner box and then cut a third piece to fit behind the second and glue it in place.

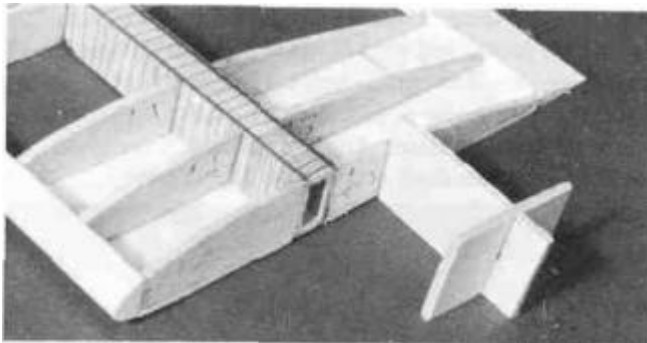

DD 21. Punch out three W1A ribs and three W1B ribs from the 1/8" die-cut balsa rib sheet (SPRTW01). Test fit these ribs into position. A little sanding may be necessary to make them fit properly. Glue these ribs into place using thick CA. The end rib should be tilted in at the top using the slanted end of the rib gauge to give it the correct angle.

DD 22. Cut and sand the leading edges, trailing edges and spars to their correct length. Lay the panel over the plans to determine the correct lengths.

BUILD THE OUTER WING PANEL

You'll need the following parts:

SPRTW03	1/16" Die-Cut Balsa Wing Ribs W4 - W10
SPRTW07	1/16" Die-Cut Balsa Shear Webs
SPRTW10	Shaped Balsa Leading Edge
SPRTW 12	Shaped, Notched Balsa Outer Trailing Edge
SPRTW14	1/8" x 5/16" x 15-1/8" Basswood Outer Spars
SPRTW15	7/8" Shaped Balsa Wing Tip Block

DD 1. Lay one of the **Outer Trailing Edges** (SPRTW 12) in place over the plan and cut it to length just past the last notch. Align the notches in the trailing edge with the notches on the plans and pin it in position. **NOTE: The un-notched end of this trailing edge will be used later if you are installing spoilers.**

DD 2. "Cross pin" one of the 1/8" x 5/16" x 15-1/8" **Basswood Outer Spars** (SPRTW 14) in place.

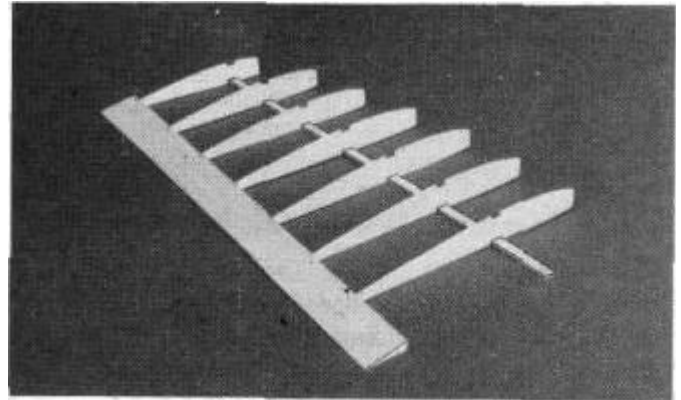

DD 3. Punch out the 1/16" (W4-W10) **Tip Ribs** out of one of the SPRTW03 die-cut sheets. Glue the ribs in place with a thick CA at the spar joint and a drop of thin CA at the trailing edge joint. Use the rib gauge to keep the ribs perpendicular.

DD 4. Trial fit the top 1/8" x 5/16" x 15-1/8" **Basswood Outer Spar** in place by carefully pressing the spar into the notches until it is flush with the top of the ribs. Remove the spar and apply thick CA to the notches. Replace the spar and allow the glue to cure.

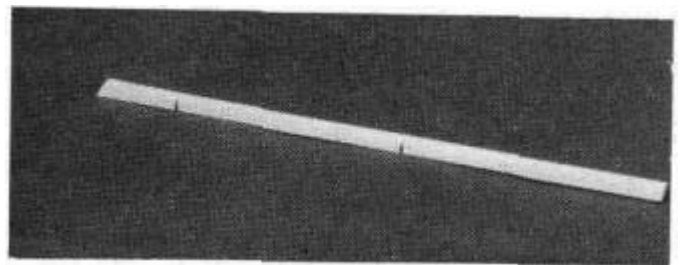

DD 5. Lay one of the remaining **Pre-Shaped Leading Edges** over the **LEADING EDGE TEMPLATE** at the top right corner of the plans. Use this drawing as a reference to cut the leading edge to length and to cut the relief notches. **It is a good idea to cut the leading edge approximately 1/4" longer on both ends to be on the safe side.** It can be cut to the correct length after it is installed. The relief notches do not need to go all the way through the leading edge but should go within 1/8" of doing so. **NOTE: You must make a "Right" and a "Left" L.E.**

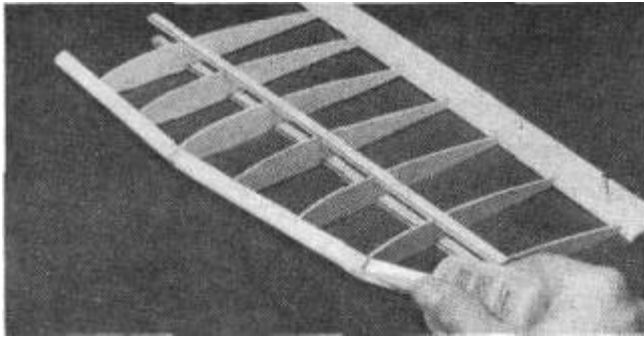

DD 6. Carefully bend the leading edge to the angle shown on the plans and position it against the ribs. The bends should be at ribs W6 and W9. Align the leading edge with the top and bottom edges of the ribs and glue it in place starting at ribs W6 and W9.

DD 7. Locate the remaining 1/16" Die-Cut Shear Webs from sheet (SPRTW07). **NOTE: These remaining shear webs are actually tapered to match the taper of the wing.**

DD 8. Punch out the remaining 6 shear webs and lay them end to end so that the end of one web is the same size as the end of the one next to it as shown in the sketch below. This is the order and direction they will be installed in the wing. The thinnest web goes between ribs W9 & W10 and the thickest web goes between ribs W4 & W5.

NOTE TAPER OF WEBS

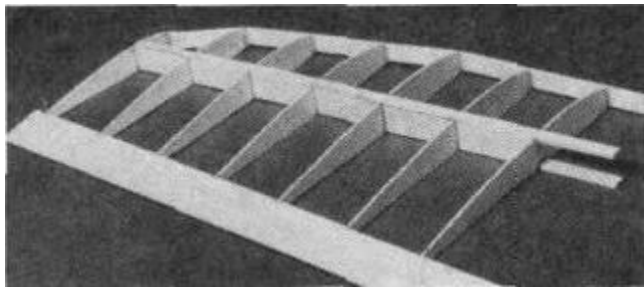

DD 9. Glue the webs into their respective places using thick CA. The thinnest end of each web goes towards the tip of the panel. The C-2 clamps can be used to help hold the webs in place while the glue cures.

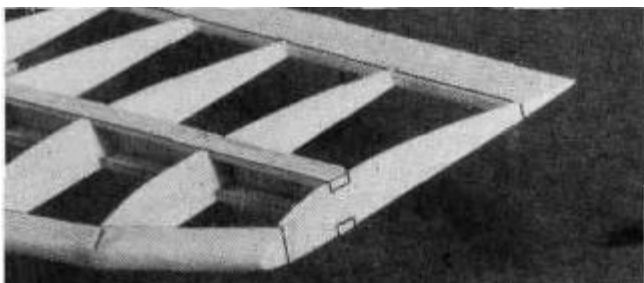

DD 10. Cut and sand the trailing edge, spars and leading edge flush with rib W10. Also cut these to the correct length at the other end using the plans as a guide.

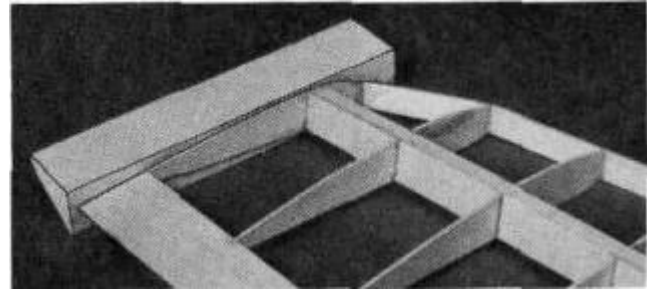

DD 11. Glue the 7/8" x 1-1/4" x 6-1/4" Tapered Wing Tip Blocks (SPRTW15) to W10 with thick CA. The sketch below and the cross sections on the plan shows how the block should be attached to get the correct tip shape.

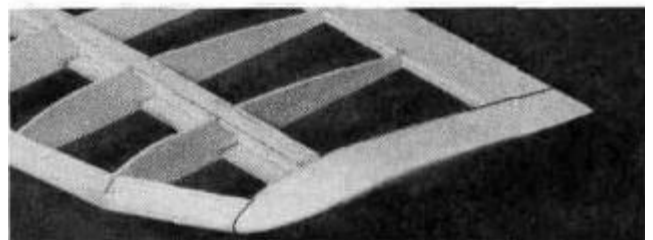
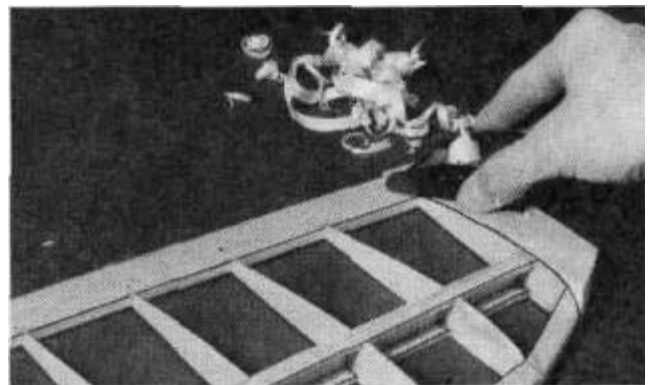
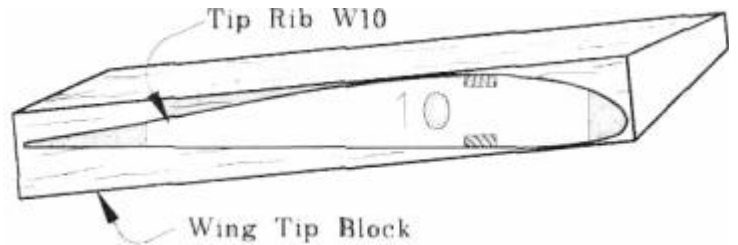

DD 12. Carve and sand the wing tip to blend in with rib W10. Be careful not to change the shape of W10 while sanding the tip. There are three section views on the left wing plan to show you the desired shape.

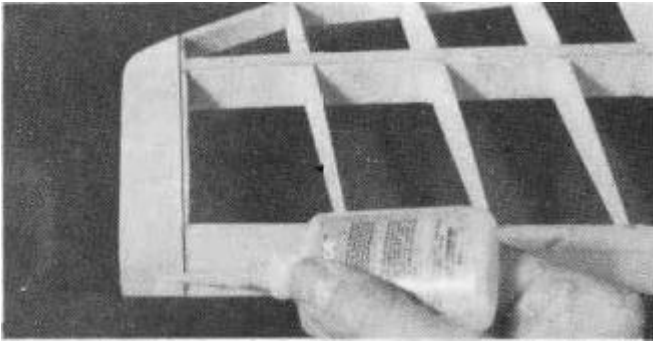

DD 13. Apply several drops of thin CA to the rear portion of the balsa wing tip. Allow the glue to soak into the wood and cure. The glue will help harden the wood and protect it from damage.

sand the leading edge, spars and trailing edge so they are all even and of the correct length.

NOTE: The SPIRIT'S wing is designed to be just under the legal maximum projected wing span for 2-meter sailplanes (approximately 78-3/4"). Be very careful when joining these panels to get the right amount of dihedral and to keep the panels the correct length or you could very easily build a wing that is too long for competition in the 2-meter class.

JOIN THE INNER AND OUTER WING PANELS

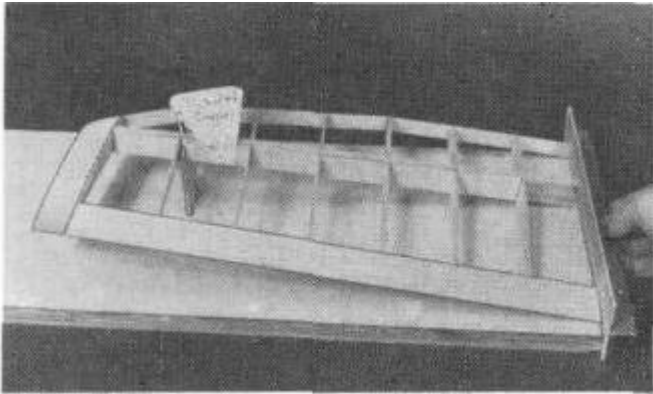

DD 1. Prop up the **outer panel** 2-5/8" (from the work surface to the bottom of W10) using the **lower** notch of the **Dihedral Gauge** (from SPRTW08) next to rib W9. Use a sanding block to carefully sand the leading edge, spars and trailing edge to achieve vertical surfaces on each. Check your progress by occasionally setting the panel on the plans to make sure you are not sanding any "sweep" (forward or backward tilt) into the wing.

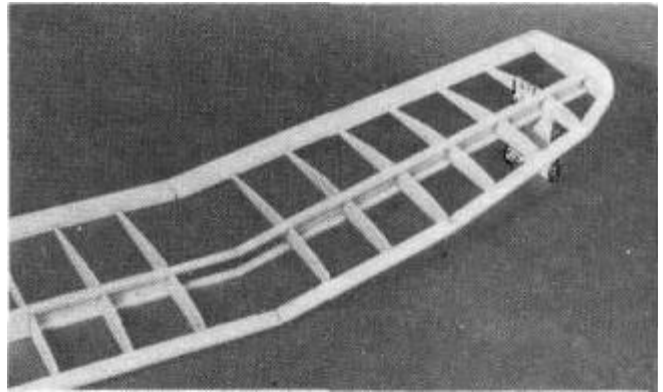

DD 3. Test fit the inner and outer panels together over the plan to make sure the leading edges, spars, and trailing edges all meet up nicely when the tip panel is blocked up the required 2-5/8" at the bottom of rib W 10 (Use the **lower** notch of the dihedral gauge at W9 as shown on the plans to obtain the correct angle). Sand any ends if needed to make everything fit well.

DD 4. With the dihedral gauge in place. Apply thick CA or epoxy to the leading edge, trailing edge and spar joints to "tack glue" the two panels together. Hold everything in place until the glue has cured.

DD 5. Punch out two of the 1/32" **Plywood Polyhedral Braces** from the die-cut sheet (SPRTW06) and test fit them in place against the front and back of the spars. Sand them if needed to achieve a good fit.

DD 6. When satisfied with the fit apply a generous bead of epoxy or thick CA to the spars and install the braces on both sides of the spars. Use the die-cut **C2 clamps** (from SPRTW08) to hold everything in place. The photo at the top of the next page shows this procedure.

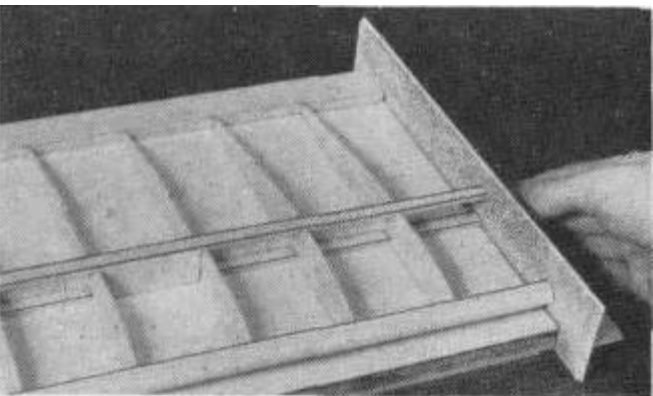

DD 2. With the **inner panel** flat on the work surface,

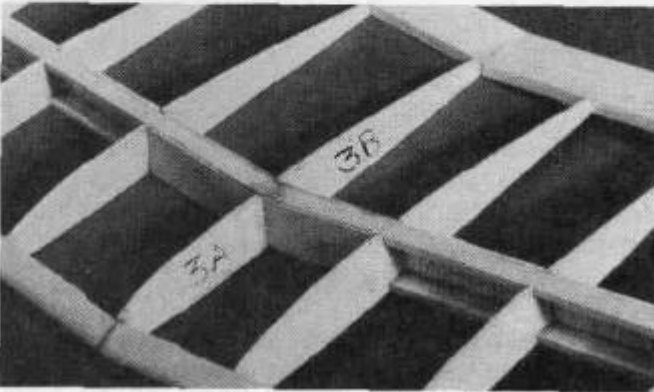
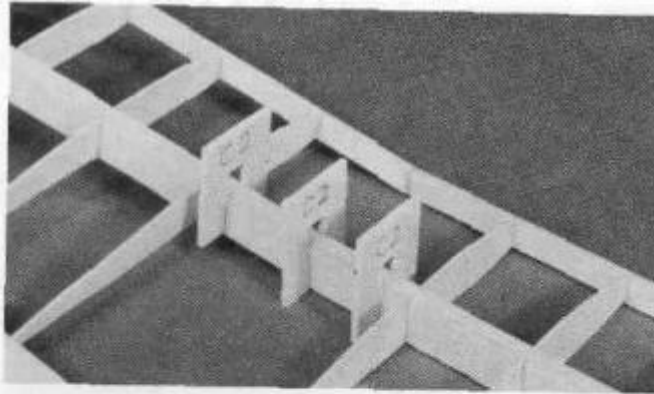

DD 7. Glue the 1/32" Plywood Polyhedral LE Brace (from SPRTW06) in place against the leading edges. Install ribs **W3A** and **W3B** between the inner and outer panels using thick CA as shown in the photo. A little sanding may be necessary to achieve a good fit. Use the rib gauge to tilt the ribs to the proper angle.

D 8. Now go back to step 5 on page 9 and assemble the other half of the wing.

FINAL WING ASSEMBLY

IF YOU ARE BUILDING A ONE-PIECE WING SKIP AHEAD TO STEP 4

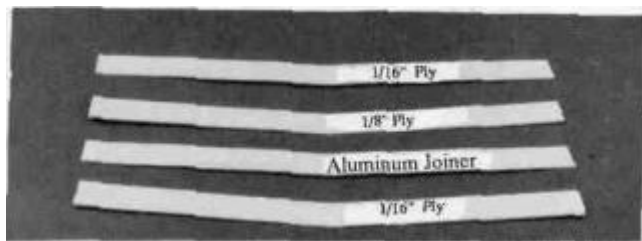

D 1. Punch out three of the 1/16" and one of the 1/8" Plywood Wing Joiner Laminations (SPRTW05 / SPRTW04) and find the aluminum joiner. Lightly sand the edges of each to remove any high spots.

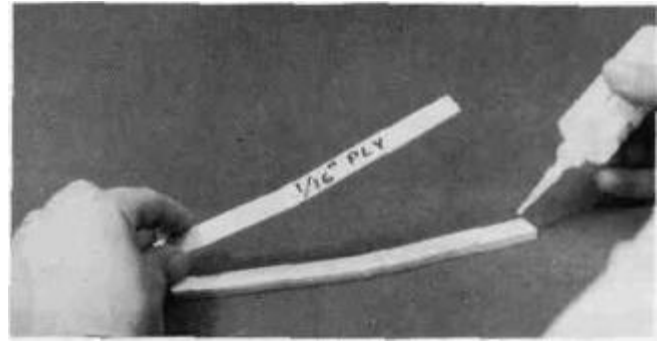

D 2. Use either epoxy or thick CA to glue one of the 1/16" laminations to the 1/8" laminations. Apply as much pressure (clamps, clothespins, weights, etc.) as possible while the glue is curing and be sure to accurately line up the two pieces. Next, glue this lamination assembly and the other 1/16" lamination, one on each side, to the aluminum joiner using epoxy (The aluminum joiner and the 1/8" Lamination should be in the middle). Clamp together until the glue cures.

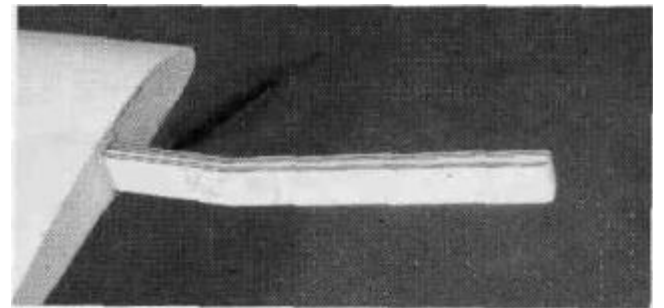

D 3. Sand the edges of the finished "wing joiner" to remove any glue globs and test fit it in the wing joiner box. Some sanding may be required to get a nice smooth **but not** loose fit.

IF YOU ARE BUILDING THE TWO-PIECE WING SKIP AHEAD TO STEP 15

D 4. Prop up one wing half 2" (as measured from the work surface to the bottom of rib W3) and sand the root (Inner) end of the trailing edge, spars and leading edges to achieve vertical surfaces as you did earlier for the outer panels. Do the same for the other wing panel.

D 5. Test fit the two inner panels together by laying one panel flat on the work surface and propping up the other panel 4" (at the bottom of rib W3). Use the dihedral gauge next to the last W2 rib to achieve the correct angle. Make sure that each spar, etc. just touches the opposite spar, etc. of the other panel. Carefully sand the longest ends until a good joint is achieved between each member.

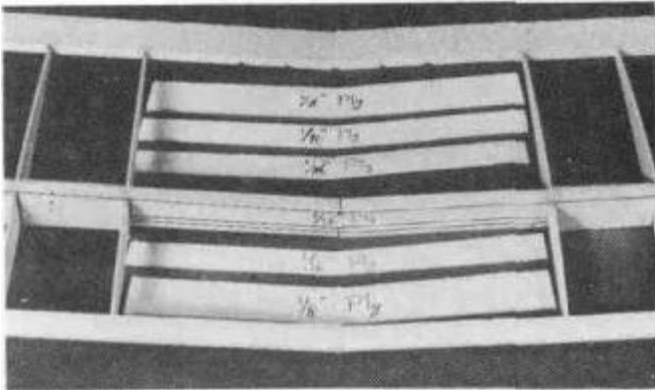

D 6. Punch out all four of the **Wing Joiner Laminations**, the **Dihedral Braces** and the **Leading Edge Brace** from the die-cut sheets SPRTW04 and SPRTW05. Test fit all of the pieces in place and sand them if necessary to make them fit nicely. The wing joiner laminations are installed between the spars and arc sandwiched in place by the dihedral braces. The C1 clamps can be used to hold everything in place.

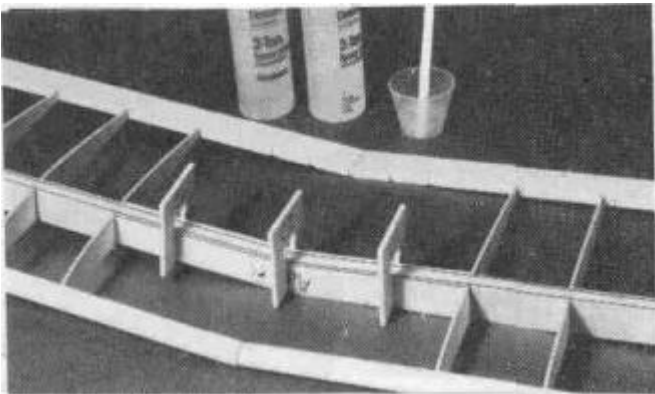

D 7. When satisfied with the fit, mix up a batch of epoxy (30 minute cure time is ideal, 5-minute is too fast), coat the joiner laminations with a layer of epoxy and install the joiner laminations between the spars. Quickly apply some epoxy to the dihedral braces and hold them in place using the C1 clamps. Also apply some glue to the leading and trailing edges and pin them together to keep them aligned with one another. Wipe off any excess epoxy that may have squeezed out before it cures. After the glue cures sand off any glue globs that may have formed.

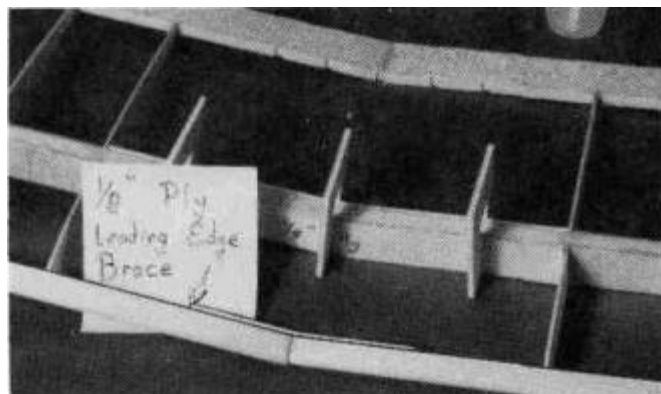

D 8. Glue the 1/8" **Plywood Leading Edge Brace** in

place using thick CA. It should be centered (up and down) on the leading edge because 1/16" sheeting will be added later.

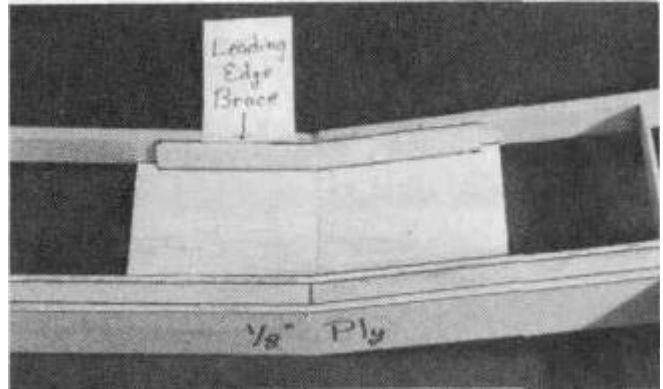

D 9. Locate one of the 1/16" x 3" x 24" **Balsa Sheets** (SPRTW17) and cut it into 6 pieces 2-3/8" long. Slide one of the sheets in place in front of the dihedral brace, trim it to fit and glue it to the LE and the dihedral brace with thick CA.

D 10. Glue another piece to the rear of the dihedral brace. then cut a third piece to fit behind the second and glue it in place.

IF YOU ARE BUILDING A ONE-PIECE WING THAT WILL BE ATTACHED WITH RUBBER BANDS, DISREGARD STEPS # 11,12,13 and 14 and instead just glue all six W1A and W1B ribs in place.

D 11. Punch out six **W1A ribs** and six **W1B ribs** from the 1/8" die-cut balsa rib sheet (SPRTW01). Test fit these ribs into position. A little sanding may be necessary to make them fit properly. Glue all six **W1B** ribs into place using thick CA (the two center W1B ribs arc glued together). Glue the **outer** two **W1A** ribs into place but the remaining four W1A ribs will not be added until later.

D 12. Cut a piece of 1/4" birch plywood (not included) to fit between the leading edge and the spars. It will be called the **Front Wing Bolt Plate** and should be approximately 2-1/8" x 2-5/16". Glue the wing bolt plate in place with either epoxy or thick CA. Add strips of 3/16 triangle stock wherever possible along the joints to help reinforce it.

D 13. Glue a W1A rib to each side of the wing bolt plate. Trim the other two W1A ribs to fit together on top of the wing bolt plate and glue them in place. Cut out a section of these two W1A ribs to clear the wing bolt as shown in the sketch on the top of the next page.

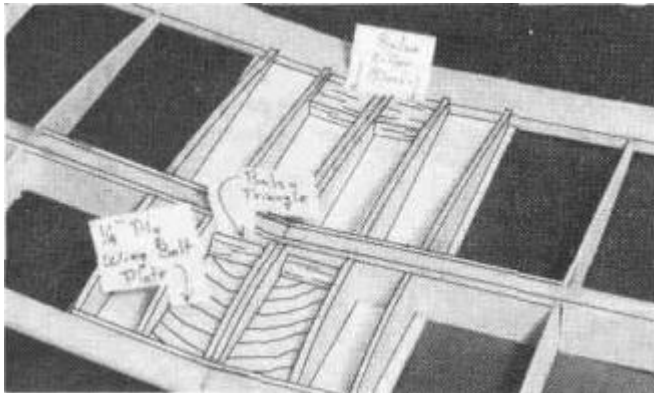
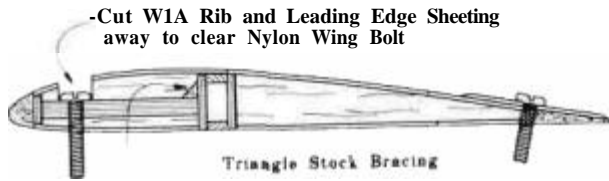

D 14. Add a 5/16" x 1" x 7/8" balsa filler block (not included) on each side of the middle W1B ribs near the trailing edge and sand them flush with the top of the ribs.

STEPS 15 - 18 APPLY TO ALL WING CONFIGURATIONS

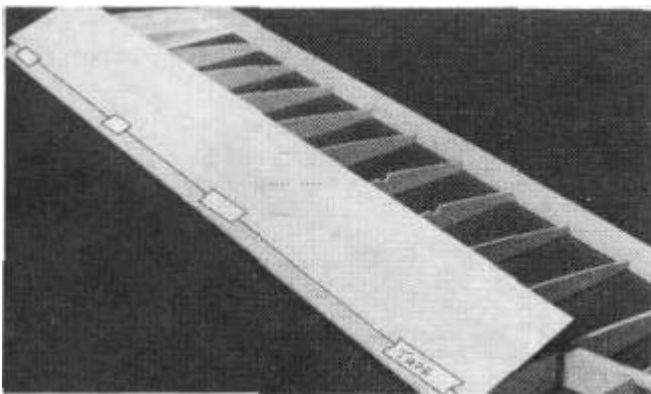

D 15. Set the 1/16" x 3" x 24" **Balsa Leading Edge Sheeting** (SPRTW17) in place on the inner panel. The outer end of the sheeting should cover rib W3A. Cut off the excess sheeting even with rib W1A. Sand the top L.E. of the ribs if necessary to allow the sheeting to be flush with the L.E.

D 16. With the 1/16" sheeting in place against the leading edge apply several strips of masking tape to hold it in place

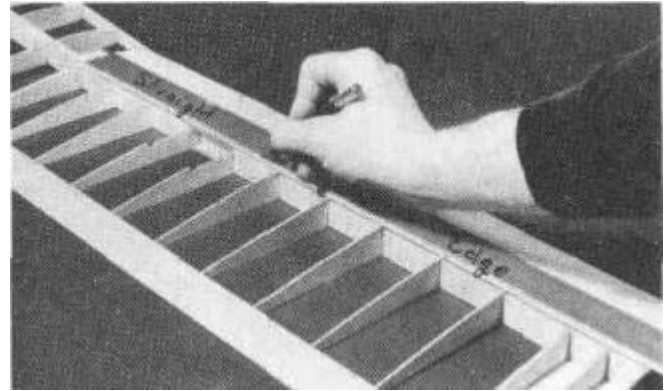

and act as a lunge for the gluing process. Press the sheeting into place and trim it flush with the back edge of the spar using a modeling knife and straightedge.

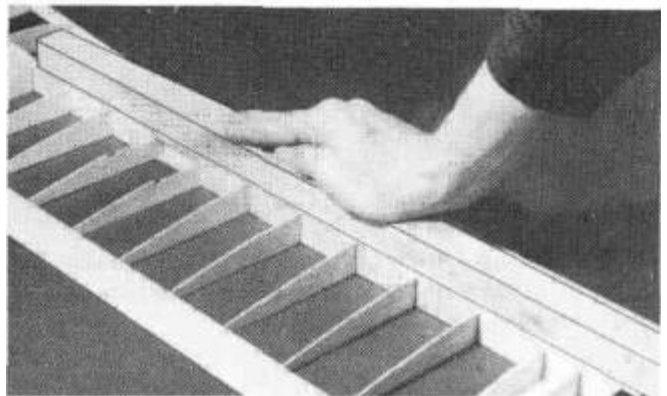
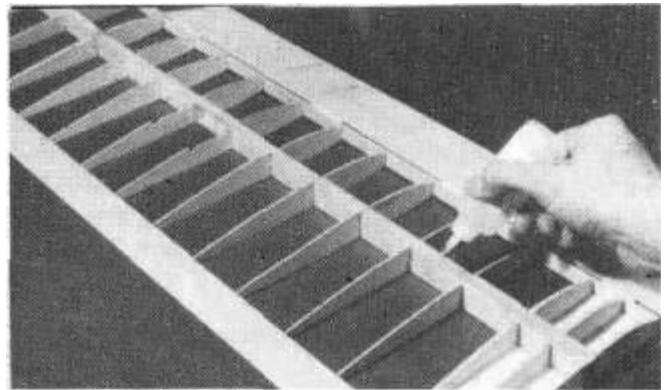

D 17. Lift the sheeting up and apply a bead of thick CA along the top spar. Quickly press the sheeting down into place and hold until the glue has cured. A **straight** strip of wood the length of the panel can be a big help when trying to hold the sheeting down evenly.

D 18. Apply a small bead of thin CA between the pieces of masking tape along the leading edge. When all of the glue has cured, remove the tape, flip the wing over and securely glue the sheeting to the ribs using thin CA as shown in the photo at the top of the next page. Poke some pin holes in the center sheeting where the center W1A rib is and apply a drop of thin CA to each hole.

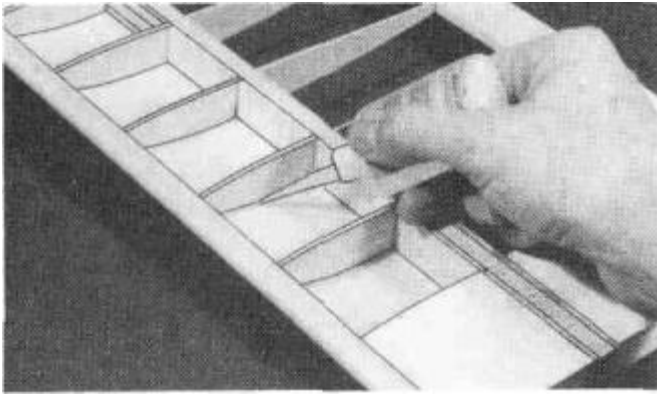

IF YOU ARE NOT INSTALLING SPOILERS SKIP TO STEP 28

D 19. Cut one 6-1/4" long spoiler from the UN-NOTCHED scrap end of each Outer Panel Trailing Edge (SPRTW12). Also cut two pieces of 3/16" x 1/4" balsa 6-9/32" long, four pieces 1-1/4" long, two pieces 1" long and two pieces of 1/16" x 1/8" balsa 6-9/32" long. This wood is not supplied in the kit but can be purchased at your local hobby dealer. Set half of the pieces aside for the other side of the wing.

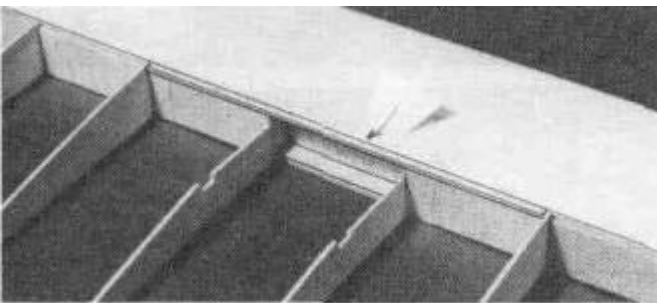

D 20. Glue the 1/16" x 1/8" x 6-9/32" piece of balsa to the back edge of the sheeting between the W2 ribs as shown on the plans and in the photo.

D 21. Glue the 3/16" x 1/4" x 6-9/32" piece of balsa in its notch on the W2S ribs. It should also be glued to the W2 ribs at the ends and it should be flush with the TOP of the ribs.



D 22. Test fit the spoiler in its bay and sand it if necessary to achieve a 1/32" gap around the sides and trailing edge. Use a strip of masking tape to temporarily hinge the spoiler in place.

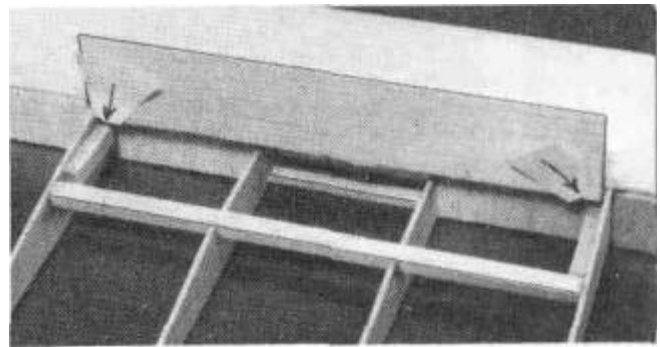

D 23. With the spoiler in place, glue the 3/16" x 1/4" x 1-1/4" pieces of balsa to ribs W2. These are the spoiler rests and should be positioned so they hold the spoiler flush with the top surface of the wing. **NOTE: It is important that the spoiler sit flush with the top of the wing or it will unnecessarily disrupt the airflow over the wing.**

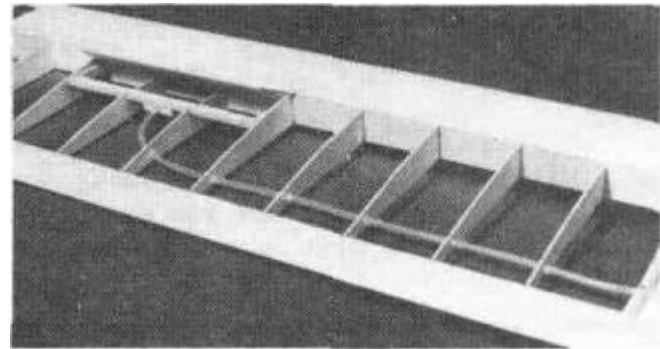

D 24. Drill 1/8" holes in the ribs as indicated on the plans and snake a 1/8" diameter nylon tubing (Inner pushrod tube or antenna tube, not included) through the ribs. Cut a 1/8" wide, 1/8" deep notch in the middle of the 3/16" x 1/4" x 1" piece of balsa and glue it to the bottom of the 3/16" x 1/4" x 6-9/32" piece trapping the end of the spoiler tube in the notch as shown in the photo.

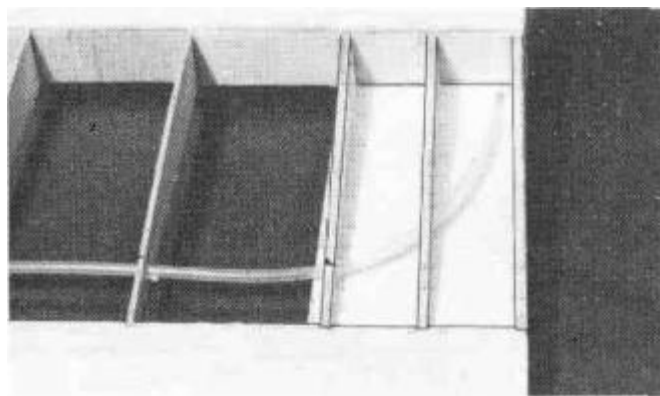

D 25. If you are using the spoiler setup shown on the plans, the spoiler tube should exit the bottom of the wing just behind the wing joiner box and the nylon tube should protrude approximately 4" to help the spoiler string clear the servos in the fuselage. Drill a 1/8" hole in the bottom center section sheeting for the tube, insert the tube in place and glue the tube to every rib and the sheeting using thick CA.

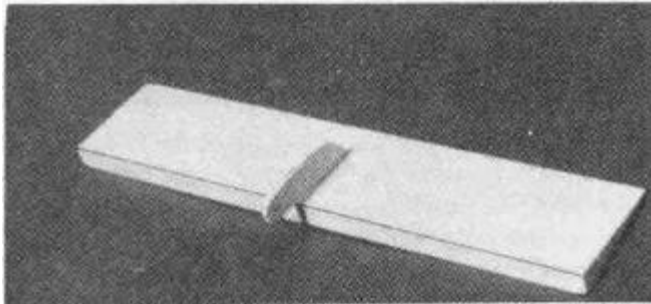
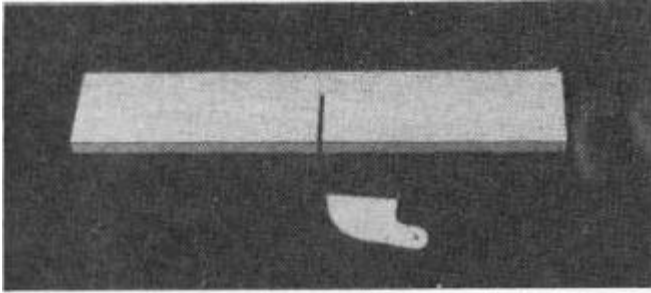

D 26. Drill a 1/16" hole in each **1/16" Die-Cut Plywood Spoiler Horn** (SPRTW05) at the indentation. Cut a 1/16" wide slot in the spoiler for the spoiler horn using a razor saw (a hack saw blade will also work fine) and glue the horn in place. It should be flush with the top surface of the spoiler as shown on the plans. This completes the assembly of the spoilers until after the wing is covered.

D 27. Assemble the spoiler on the other wing panel.

STEPS 28 AND 29 APPLY TO ALL WING CONFIGURATIONS.

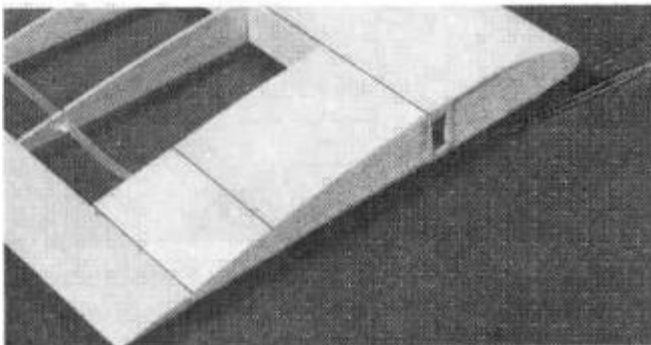

D 28. Use the remaining piece of 1/16" balsa sheeting to sheet the top inboard center section out past rib **W1B** as shown in the photo. Thick CA should be used for this step. Pre-cut the sheeting to fit first near the spars, and cut a second piece to fit between the first piece and the trailing edge. Glue these in place and if you built a two-piece wing, sand the sheeting flush with the **W1A** and **W1B** ribs at the wing root.

D 29. If you built a two-piece wing, trial fit the two wing halves together using the plywood wing joiner. Sand the root of each panel if necessary to achieve a nice close joint between the two wings. If there are large gaps, glue a sheet of 1/16" balsa to the root of the panels to fill the gaps. Sand

these sheets to match the contour of the wing and be careful not to add much to the wingspan with these extra sheets.

D 30. Sand three edges (two short and one long edge) of each 1/16" **Plywood Wing Protector** (SPRTW18) to a taper as shown on the plans and glue them in place on top of each trailing edge. They should be oriented so the unsanded edge is flush with the back of the trailing edge and they should be placed 9/16" away from the root of the wing. These will protect the wing trailing edge from being dented.

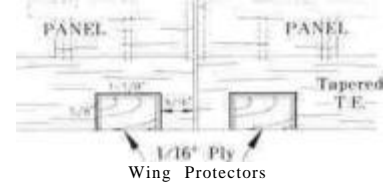

FUSELAGE ASSEMBLY

You'll need the following items:

- SPRTF01 3/32" Balsa Fuselage Sides, Wing Saddle Tripler
- SPRTF02 3/32" Balsa Fuselage Doublers
- SPRTF03 1/8" Plywood From Fuselage Bottom
- SPRTF04 1/16" Balsa Rear Fuselage Sheeting
- SPRTF05 1/8" Plywood Formers
- SPRTF07 1/8" Square x 24" Balsa Stringer
- SPRTF08 3/16" x 30" Balsa Triangle
- SPRTW05 1/16" Plywood Towhook Plate

ASSEMBLE FUSELAGE SIDES

D 1. Pin or tape the fuselage plan to your flat work surface and cover it with waxed paper. Pin one of the 3/32" Die-Cut Balsa Fuselage Sides (SPRTF01) down ABOVE the FUSELAGE SIDE VIEW so you can use the plan for reference. This is going to be the **LEFT** fuselage side.

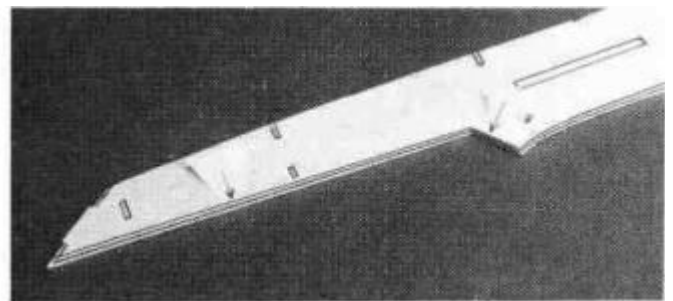

DD 2. Trial fit one of the 3/32" **Die-Cut Balsa Front Fuselage Doublers** (SPRTF02) onto the 3/32" **Balsa Fuselage Side**. The doubler should line up with the fuselage where the canopy will sit. The arrows in the photo point out this area. Spread a thin layer of thick CA on the doubler and glue it to the fuselage side.

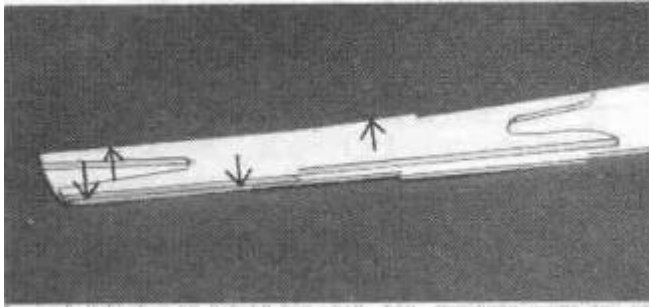

DD 3. Glue the 3/32" **Die-Cut Balsa Rear Fuselage Doubler** (SPRTF02) in place making sure it lines up with the fuselage sides at the rear of the doubler where the arrows in the photo arc pointing.

DD 4. Glue one of the 3/32" **Die-Cut Balsa Wing Saddle Triplers** (SPRTF01) in place on top of the front fuselage doubler. Do not let the tripler overlap the notches for the formers.

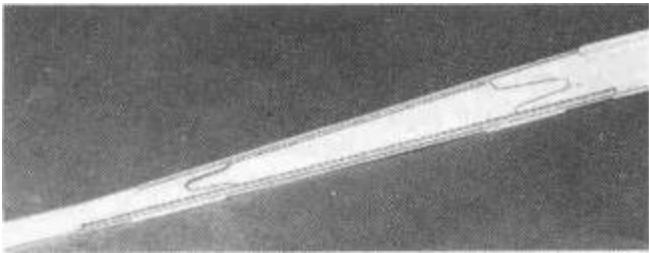

DD 5. Cut one of the 1/8" **Square Balsa Stringers** (SPRTF07) to fit between the notch for former F5 and the rear doubler and glue it in place making sure it is lined up flush with the top edge of the fuselage side (excluding the tabs). Cut another 1/8" sq. balsa stringer to fit along the bottom between the rear doubler and the notch for former F5 and glue it in place. Make sure it is lined up flush with the bottom edge of the fuselage side (excluding the tabs).

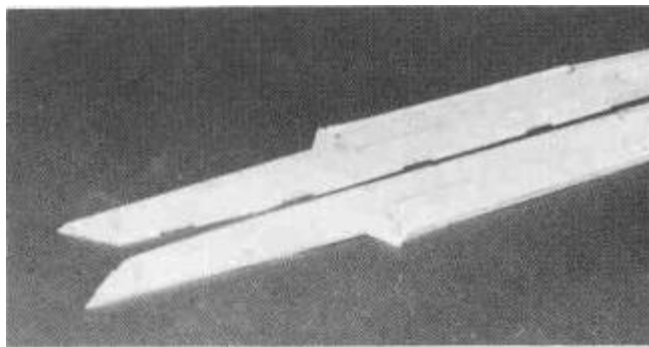

D 6. Go back to step 2 and assemble the **RIGHT** fuselage side. The easiest way to do this is to pin the other fuselage side upside down above the one you just built as shown in the photo. **MAKE SURE YOU ARE NOT BUILDING TWO IDENTICAL SIDES, THEY SHOULD BE THE OPPOSITE OF EACH OTHER.**

FRAME-UP THE FUSELAGE

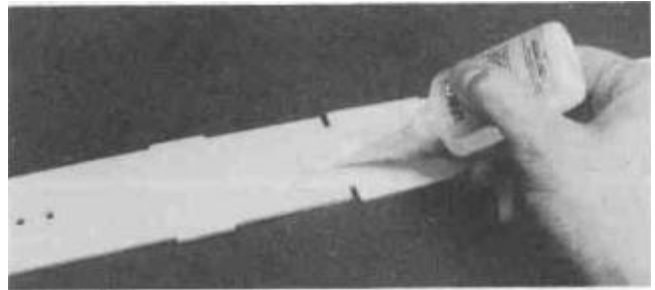

D 1. Lay a piece of waxed paper over the **FUSELAGE TOPVIEW**. Assemble but do not glue **glue** yet 1/8" Die-Cut Plywood Front Fuselage Bottom (SPRTF03) and the 3/32" Die-Cut Balsa Rear Fuselage Bottom (SPRTF04) together over the **FUSELAGE TOP VIEW** on the plans. The 1/8" plywood bottom should be installed with the three towhook hole marks **DOWN** so you can tell where to drill the towhook holes after the fuselage is assembled. Make sure the bottoms are aligned with the plan and that both pieces are pushed firmly against the work surface to even up the bottoms. If the joint is a nice tight fit, apply thin CA to the joint. If the joint is a little loose, take the bottoms apart, apply thick CA and reassemble them.

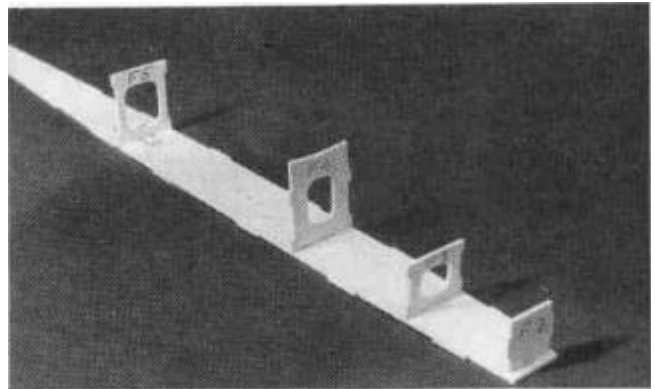

D 2. Trial fit all of the 1/8" **Plywood** Formers (except F1) in the respective notches in the fuselage bottom and sand them if needed to make them fit properly. Use thick CA to "Tack" glue the formers in place. The notches in the fuselage sides will align the formers correctly.

D 3. Align the fuselage sides with the fuselage bottom and position the formers so they will key into the notches. Remove the assembly from the work surface and use rubber bands to hold it all together.

D 4. Check the fit of the 1/16" Plywood Tow-hook Plate (SPRTW05) in its slot between formers F4 and **F5**. Enlarge the slot if needed to make the plate fit and glue it to the

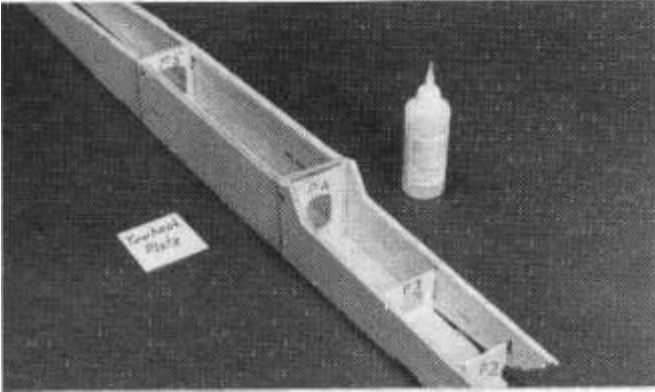

fuselage bottom with thick CA. Use the fuselage sides to help position it.

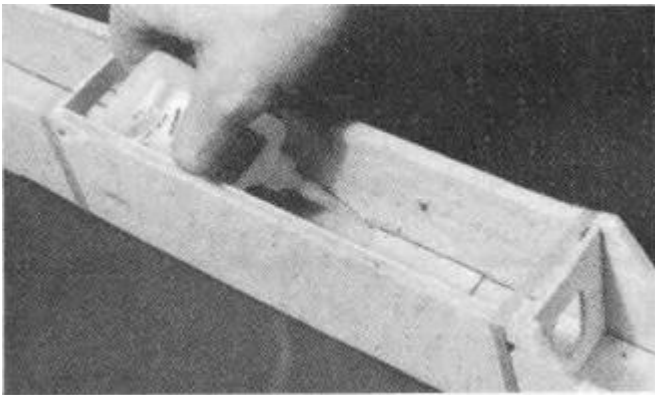

D 5. Spread the fuselage sides out and apply thick CA to formers F4 and F5 and the fuselage bottom between them. Reassemble, check to make sure the sides are pressed firmly against the formers and the bottom is fully seated against the sides, and allow the glue to cure.

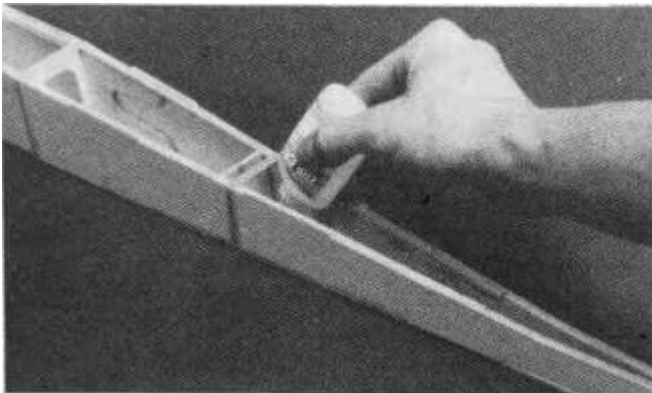

D 6. Pull the rear fuselage sides together and make sure that the sides are pressed firmly against former F6 and that the bottom is fully seated against the fuse sides. A couple of C2 clamps can be used to hold the tail of the fuselage together and rubber bands will help around the formers. Apply a couple of drops of thick CA on the back edge of the rear fuselage doubler and a bead of thin CA along the bottom sheeting

joints and around former F6. Take your time applying the thin CA and be sure to get the bottom and the sides pressed together nicely. Thick CA can then be added to these joints to add strength.

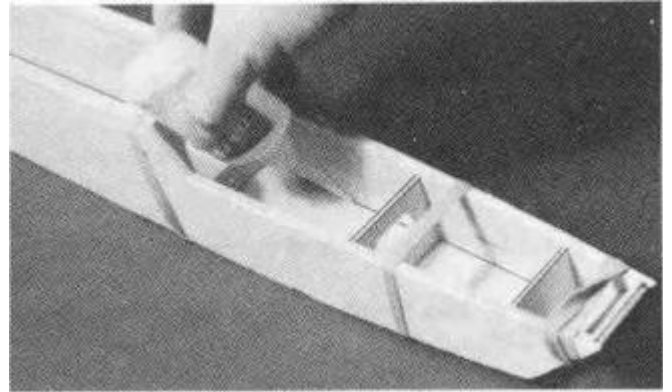

D 7. Pull the front fuselage sides together and trial fit the 1/8" Plywood Former F1 in place. Apply thick CA to the front fuselage bottom and the formers, install F1 and pull the fuselage sides together. A few rubber bands can be used to help hold the assembly while the glue cures.

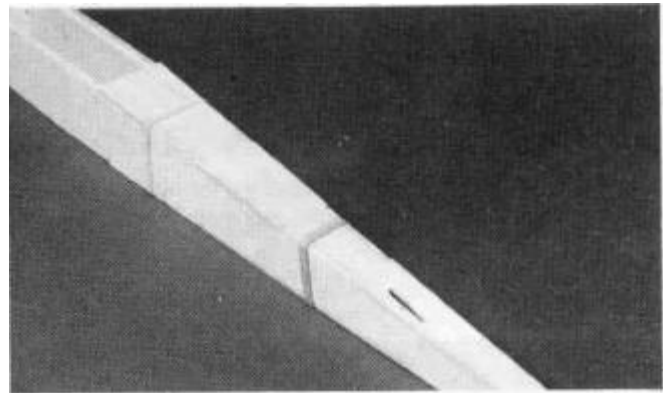

D 8. Trial fit the 3/32" **Balsa Rear Top Fuselage Sheet** (SPRTF04) in place*, and when satisfied with its fit apply a bead of thick CA along the 1/8" balsa stringers, the fuselage doublers and the fuselage sides and glue it in place. ***NOTE: The top sheeting should be installed so the rudder pushrod cut-out is on the left side of the fuse. Check the plans for the proper orientation.**

D 9. Cut the 3/16" **Balsa Triangle** (SPRTF08) into the following lengths:

- two pieces - 4-5/8" long
- four pieces - 2" long
- two pieces - 4-1/16" long
- two pieces - 2-7/8" long
- one piece - 1-1/4" long

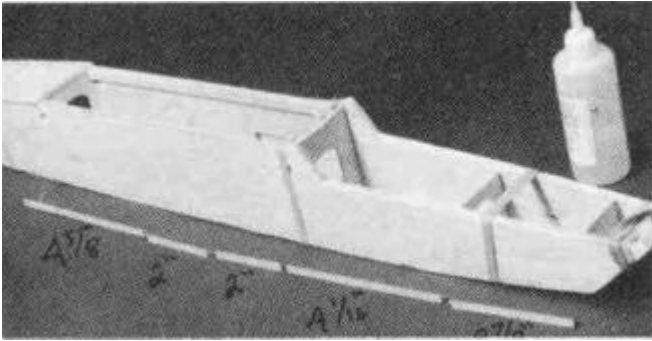

These pieces should be glued with thick CA. They are pressed into the corner between the fuselage bottom and the fuselage doubler in the following places:

Glue the 4-5/8" pieces behind the towhook plate.

Glue the 2" long pieces on top of and in front of the towhook plate.

Glue the 4-1/16" long pieces between formers F3 and F4.

Glue the 2-7/8" long pieces between former F2 and F3.

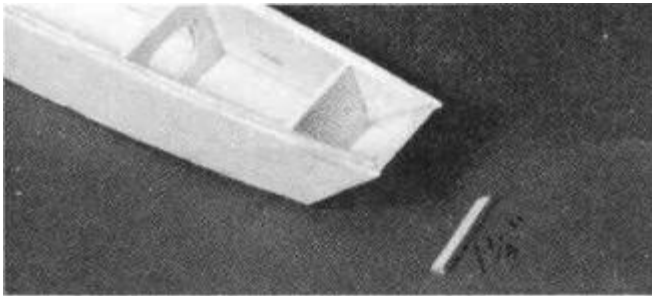

And glue the 1-1/4" long piece along the bottom between formers F1 and F2 to seal the gap there.

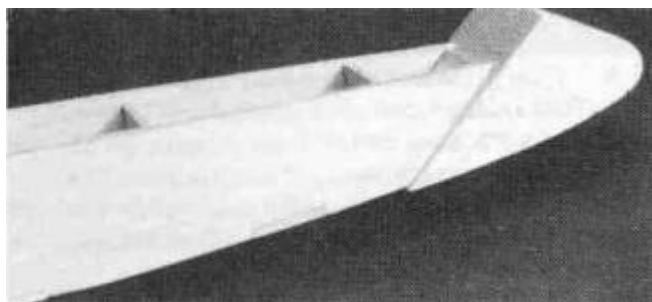

D 10. Sand the fuselage sides and bottom flush with the front of former F1 and glue the **Shaped Balsa Nose block** (SPRTF10) in place with thick CA. The bottom of the nose block should overlap the fuselage bottom by about 1/32" to allow for sanding to final shape.

D 11. Drill three 9/64" (1/8" is light but will work) holes in the 1/8" plywood bottom for the towhook. There should be three indentations to show you where to drill. Gently Tap the **three** 4-40 Blind Nuts (NUTS001) into the holes (from the

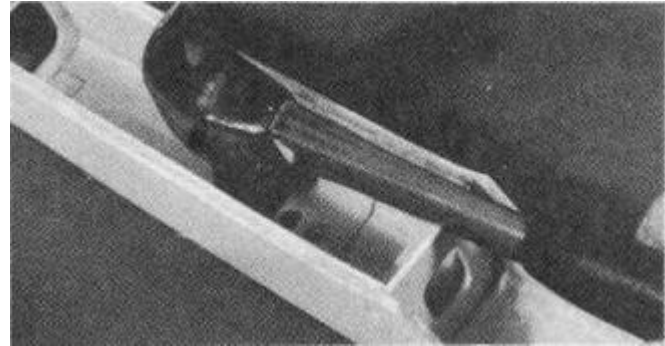
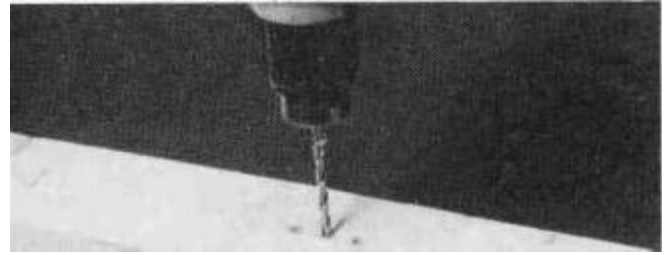

inside of the fuselage) with a hammer and put a drop of thick CA around the outside edge of each blind nut (be careful not to get glue inside the blind nut!).

IF YOU ARE NOT BUILDING A BOLT-ON WING SKIP AHEAD TO "ASSEMBLE THE CANOPY".

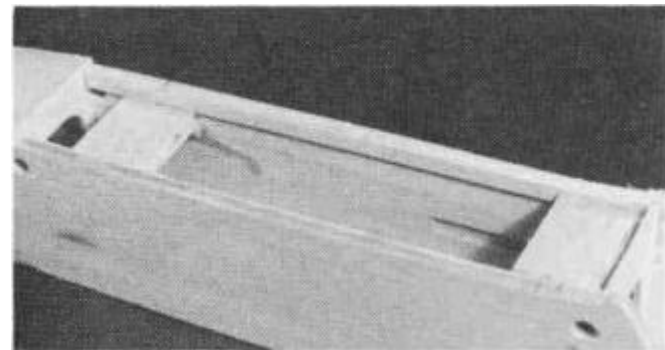

D 12. Cut two pieces of 1/4" birch plywood (not included) which will be drilled and tapped for the wing bolts. The front piece should be approximately 2-1/32" x 1" and the rear piece should be approximately 2" x 1". You will want to measure your fuselage to make the parts fit properly. You should cut the wing saddle tripler away so the blocks can glue directly to the fuselage doubler. Securely glue these in place with thick CA or epoxy. Glue triangle stock around each one for extra strength.

D 13. Glue a 1/16" Plywood Rear Wing Bolt Plate (not included) on top of the wing trailing edge to protect it from being crushed by the rear wing bolt (see the wing plan top view for the approximate size and shape).

D 14. Insert the 1/4" wing dowels in the holes in the fuselage and temporarily rubber band the wing in position on the fuselage and use a string as shown in the sketch to make sure it is on straight. Make a couple of marks on the wing and fuse to help you make sure it stays in position while drilling the wing bolt holes.

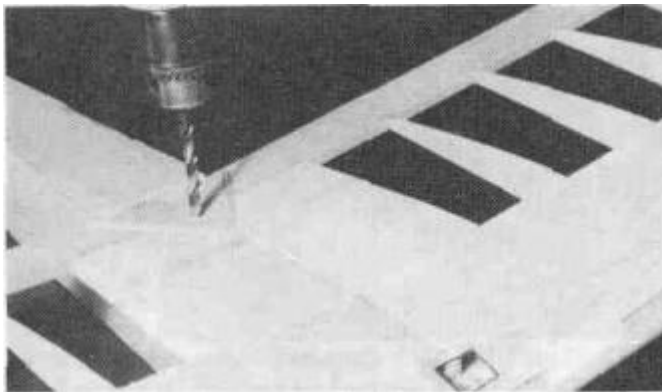
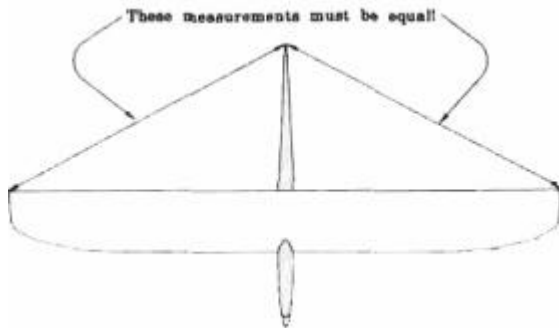

D 15. Drill a 13/64" hole through the wing and 1/4" ply plate in the fuse approximately 1" behind the front of the leading edge. Drill another 13/64" hole approximately 1-1/4" in front of the rear of the trailing edge as shown on the FUSELAGE SIDE VIEW of the plans.

D 16. Remove the wing and enlarge the two holes in the wing to 17/64". Use a 1/4 - 20 tap to thread the holes in the fuselage blocks. Test fit the wing in place with 1/4 - 20 nylon bolts (not included). Cut the 1/16" top sheeting away to clear the front wing bolt.

ASSEMBLE THE CANOPY

You'll need the following items:

SPRTF06	1/8" Balsa Canopy Base
SPRTF05	1/8" Plywood Canopy Front and Back
CANPY044	Clear Canopy
SPRTF12	Formed ABS Cockpit

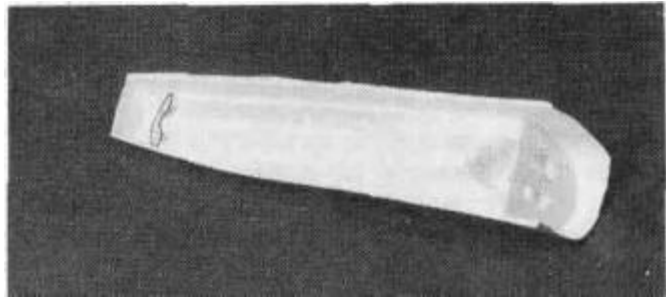

D 1. Trial fit the 1/8" Plywood Canopy Back (SPRTF05) and the 1/8" Plywood Canopy Front (SPRTF05) in place in the Formed ABS Cockpit (SPRTF12). Sand them if necessary for a good fit and then glue them in place with thick CA.

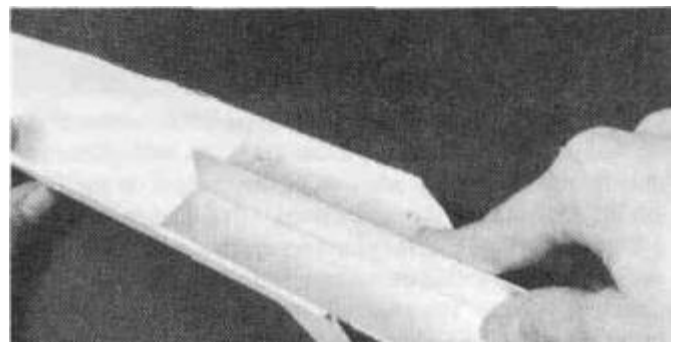

D 2. Sand the bottom edges of the canopy front and back flush with the bottom of the cockpit. Be careful not to sand through the cockpit. A small flat file works well for the front former.

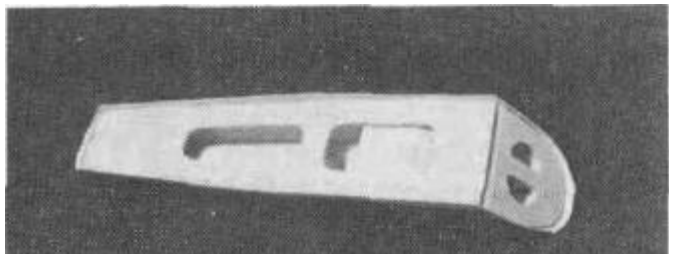

D 3. Check the fit of the 1/8" Balsa Canopy Base (SPRTF06) in the cockpit. Sand the sides of the base until it will easily fit into the cockpit. When satisfied with the fit glue it in place with thick CA.

D 4. Cut and sand off the extra cockpit material flush with the edges of the canopy back, canopy base, and canopy front. Saturate the front edge of the canopy base with thin CA and allow it to soak in and cure. This is where the canopy hold down dowel will rest. Sand the front and back edges of the base flush with the Canopy Front and the Canopy Back.

D 5. Paint the cockpit with the color scheme of your choice. Test the paint you are going to use on a piece of the plastic you cut off to make sure it will not affect the plastic. Regular plastic model paints usually work well for this. Do not paint the edges of the cockpit where the canopy will attach or the glue will not hold as well. Striping tape can be used to cover that seam. Lightly sand the edges to help the canopy adhere.

D 6. The canopy may have a Plastic Film on either or both sides. Check for this and remove it if you find one. Tint the **Canopy** (CANPY044) if you wish, using powdered clothing dye that you can buy at the grocery store (Rit, etc). Use very warm water (warmer than you can leave your hand in) but do not use very hot water or the canopy may deform. The warmer the water and the longer you leave the canopy in the dye, the darker the tint will be. Liquid dyes do not seem to work as well.

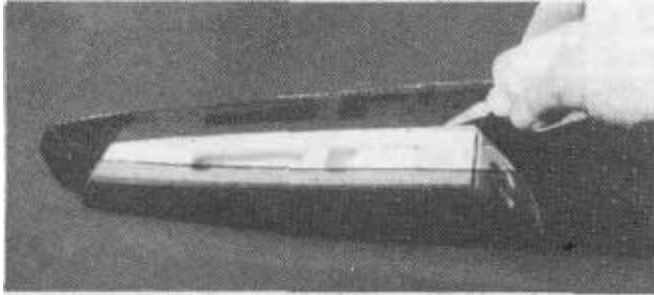

D 7. Set the cockpit inside the canopy and line the cockpit up with the scribe lines in the canopy. The scribe lines are only for reference while positioning the cockpit, do not try to get the cockpit to fit the scribe lines. Glue the canopy to the cockpit using CA. Use the glue very sparingly by holding the cockpit in place inside the canopy and apply glue a drop at a time to the seam. The glue will seep in along the seam and provide a nice clean glue joint. Work your way around the canopy and don't get in a hurry or you may get too much glue in there and it will run down the canopy. Be careful not to twist or move the cockpit once you start gluing it in place.

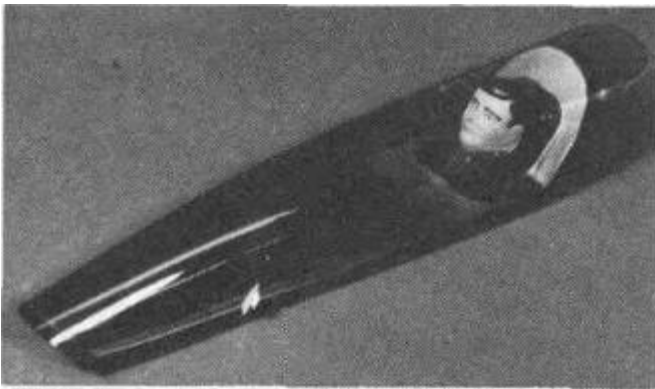

D 8. Trim the canopy flush with the base and the front but **do not trim the back yet!** A small pair of scissors works well for trimming the canopy. Temporarily mount the wing in place on the fuselage. **VERY CAREFULLY** trim the back of the canopy, **A LITTLE AT A TIME**, to fit over the wing. Take your time and use the outlines on the plans and the wing for guides.

D 9. Test fit the canopy onto the fuselage. You can sand the edges of the canopy slightly or you can sand the fuselage/nose block if needed to get it to fit properly. You can also add a layer of balsa to the back edge of the nose block to take up any extra gap if needed.

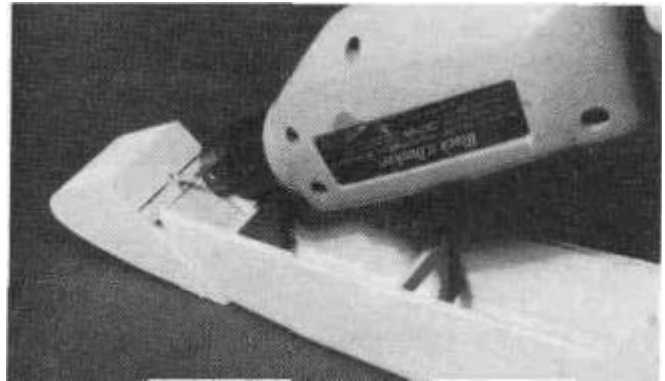

D 10. Measure up along the nose block 1/4" from the fuselage side and make a mark. Do this on both sides of the nose block and then draw a line across between the two marks. Measure to the middle of this line and make another mark. Drill a 1/8" diameter hole about 1" deep at approximately the angle shown on the plans right where you made the last mark.

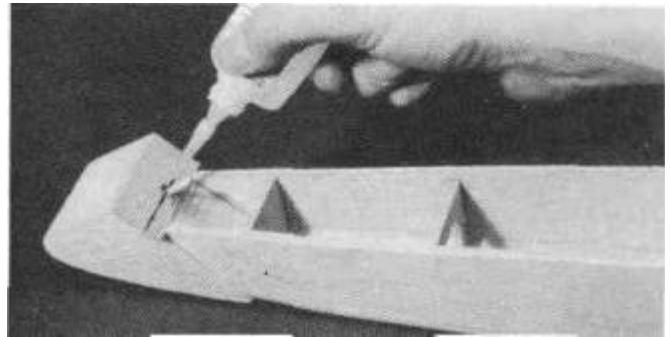

D 11. Insert the 1/8" diameter Canopy Hold Down Dowel (DOWEL033) into the hole and slide the canopy into place to make sure it fits nicely. The dowel should hold the canopy down against the fuselage. If it is too loose you can either enlarge the hole slightly and move the dowel down or you can build up the top surface of the canopy base with thin plywood and/or thick CA. Glue the dowel in place with at least 1/4" extending.

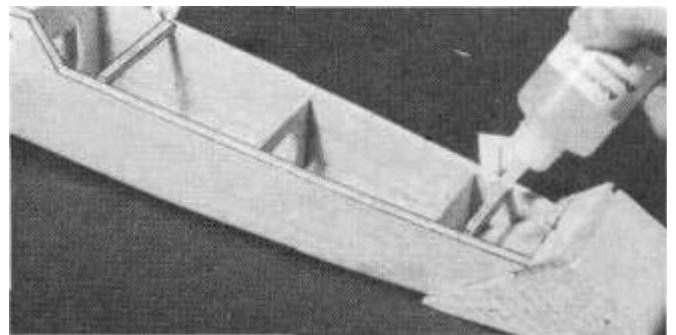

D 12. Cut two pieces of 1/8 x 3/16" balsa (from SPRTS03), one 1-7/8" long and the other 1-1/4" long. Wedge the longer piece between the fuselage sides above the receiver compart-

merit and wedge the other one between the sides in the weight compartment. These pieces are called the **Canopy Aligners**. Lift the aligners so that they are slightly above the sides. Apply a small drop of thick CA to the middle of each aligner and carefully slide the canopy into place. Push down on the canopy to force the aligners against the canopy base (with the canopy aligned with the fuselage sides) and hold it until the glue has cured (a couple of minutes). Carefully remove the canopy and securely glue the aligners to the canopy base with more CA.

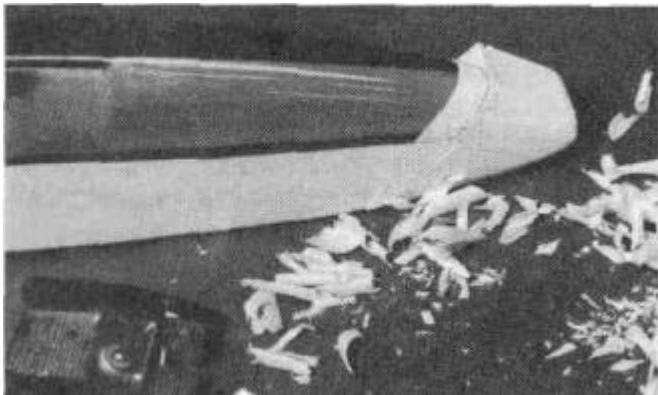

D 13. Apply a couple strips of masking tape around the front of the canopy to protect the plastic and install the canopy on the fuselage. Use a razor plane, hobby knife or sanding block with coarse grit sandpaper to rough carve the nose block to shape.

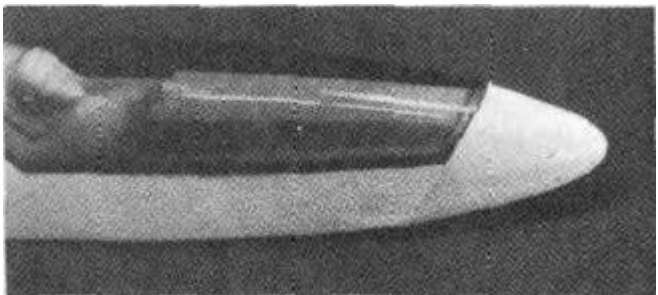

D 14. Use your sanding block with medium and then fine grit sandpaper to smooth out the nose block and fair it in with the canopy and the fuselage.

FINAL ASSEMBLY

BALANCE THE AIRPLANE Laterally

SPECIAL NOTE: Do not confuse this procedure with "checking the C.G." or "balancing the air-

plane fore and aft". That very important step will be covered later in the manual.

Now that you have the basic airframe nearly completed, this is a good time to balance the airplane **laterally** (side-to-side). Since the wing is the major factor on a sailplane, we will only be concerned with it. Here is how to do it:

1. Set the wing on a flat surface and hold it so that both wing tips are level. Let go of the wing and notice which wing tip drops. Do this several times and if the same wing tip keeps dropping push a thumbtack or small nail through rib W 10 into the wing tip that keeps rising.

2. Perform this test several times until the wing balances or the same wing tip does not drop every time and then glue the tacks or nails in place with a drop of thin CA.

FINAL Sanding

Check over the entire structure carefully, inspecting for any poorly glued joints, gaps and "dings". Apply additional glue and/or balsa filler as necessary, then sand the entire structure smooth using progressively finer grades of sandpaper. Sand the fuselage corners to a rounded shape as shown **on** the cross sections of the plans.

Covering

There are many different types of covering materials available these days but the iron-on type coverings are by far the easiest to use and in most cases the best suited for the job. There are also several different brands of iron-on coverings available. We recommend you use Top Flite Super Monokote for covering your SPIRIT due to this covering's higher strength. Sailplanes, which usually have higher "aspect ratio" wings (long and thin), gain a great deal of strength from the covering. This is evident by gently twisting the wing before and after it is covered, it is hard to believe the difference. Because of this, the higher strength coverings are best suited for sailplanes.

The following are some covering tips we have learned over the years but you should **follow the instructions included with your covering material**.

- Sand the surfaces as smooth as possible before starting to cover the plane. The finished covering job will only be as smooth as the surface you started with.

- Use a fresh single-edge razor blade or hobby knife blade and replace the blade as soon as it starts showing signs of dulling.

- Set the iron to the proper temperature by first applying a "test strip" on a scrap of balsa.

- Work outward, start by tacking the covering in place at the comers and then start in the middle and work your way out to the comers, gently pulling any wrinkles out as you go.
- Securely seal all edges! Make sure the edges are firmly sealed down to prevent the covering from pulling away at the seams when shrinking the panel.

NOTE: When covering the fin, begin by applying a 1/2" wide strip of covering on each triangle. Next, cover the rest of the fin with pre-cut pieces that have a straight edge to overlap (1/8"+ overlap) the strips you previously applied. This is a tip you should remember as it makes it a lot easier to cover "compound" curves.

Because the fin has to glue on top of the stab and the stab has to glue to the fuse you do not want to cover where these surfaces will glue to each other. The following instruction will explain how to do this.

D 1. Position the stabilizer on the fuselage and aligned with the fuselage using the procedure at step 3 on page 27. Hold it in place and mark along the fuselage/stabilizer joint with a felt pen to show where not to cover.

D 2. Position the fin in place on top to the stab. Make sure **it** is centered and pointing straight ahead, and mark around the base with a felt tip pen.

D 3. When applying the covering to the top and bottom surfaces of the stab, do **each** side with **two** pieces of covering. Do not cover between the lines. Cut the covering to fit around the lines **before** you iron it in place. Also **do not** cover each surface of the slab with one sheet of covering and then cut the covering away between the lines. Doing this leaves "cut lines" in the wood and greatly weakens the stab structure.

Recommended Covering Sequence:

1. Strips as described in above note
2. Fin left side
3. Fin right side
4. Rudder left side
5. Rudder right side
6. Bottom of elevator
7. Top of elevator
8. Stab bottom right side
9. Stab bottom left side
10. Stab top right side
11. Stab top left side
12. Fuse bottom
13. Fuse sides
14. Fuse top
15. Bottom of left wing panels (inner and outer)
16. Bottom of right wing panels (inner and outer)

17. Top of left wing panels (overlap covering 1/4" at LE and TE)
18. Top of right wing panels (overlap covering 1/4" at LE and TE)
19. Spoilers if installed

CHECKING FOR WARPS

This is a very important step and should be done every once in a while throughout the flying season. A sailplanes wing is **most efficient** when it is not twisted or warped at all. "Washout" (wing trailing edge twisted up at the tip) helps make a poor wing design fly better by adding some stability (preventing stalls) at slow speeds but it cuts down on the wing efficiency at normal speeds. The SPIRIT'S wing is designed to fly well at slow speeds without any washout and therefore we recommend you check to make sure the wings are "flat" using the following procedure.

D 1. Set the wing so an inner panel is resting on a flat surface. Any warp (twist) will show up by causing a corner of the panel to rise off of the work surface.

D 2. To remove the warp, gently twist the wing in the opposite direction while a helper glides an iron or heat gun over the covering on both the top and the bottom of the panel to re-shrink the covering. Hold the twist until the covering cools and then recheck for warps. It may take several tries to get a warp out but it is worth it as you will end up with a sailplane that flies straight and true and responds to air currents like a high performance sailplane should.

D 3. Follow the same procedure to check all four wing panels and then go back and double check them. Sometimes you put a warp in one panel while trying to fix another. You should also look at the tail surfaces as they too can warp.

GLUE THE HINGES

D 1. Lay the rudder and elevator on the plans and mark on the leading edge of each part the locations of the hinges. Now use a sharp hobby knife to cut slits in the covering at the hinge locations. Trial fit the hinges to make sure you have "found" the slots which you previously cut. In the same manner, slit the covering at the hinge locations in the stab and fin TE.

D 2. When gluing the hinges it is important that plenty of glue gets inside the hinge slot. If you just put glue **on the** hinge, most of it will be wiped off as the hinge is inserted into the slot. A good way of getting glue into the slot is to scoop up some epoxy with a plastic soda straw, then pinch the end of the straw, insert it into the slot, and squeeze the straw to force the glue into the slot. Apply epoxy to the hinges, insert

them into place (up to the middle of the hinge) and wipe away **all** excess epoxy with a tissue (for best results dampen the tissue with rubbing alcohol).

MOUNT THE TAIL SURFACES

D 1. Use your sanding block with medium grit sandpaper to chamfer (slightly round) the ends of the **1/4" Hardwood Wing Dowels** (DOWEL030) Insert the 1/4" wing dowels in the holes and secure with thick CA. (**Omit this step if you are using a bolt-on wing.**)

D 2. Rubber band or bolt the wing onto the fuselage making sure it is square and centered with respect to the fuselage.

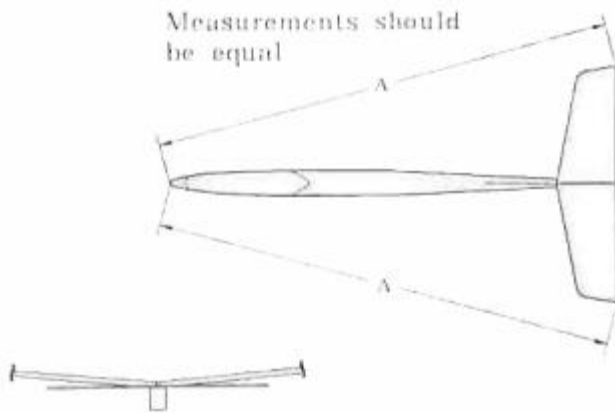

D 3. Position the stabilizer on the fuselage and measure to get it centered and properly aligned. Glue the stabilizer to the fuselage with either thick CA or epoxy. Check its alignment with the wing while the glue is curing to make sure they are level with each other.

D 4. Position the fin in place on top of the stab. Glue the fin in place on top of the stab and fuse using either thick CA or epoxy. Check to make sure it is pointing straight at the nose and is vertical (90 degrees) to the stab.

ASSEMBLE PUSHRODS

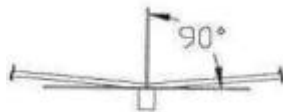

D 1. Harden the balsa in the area of the control horns (on both sides of the control surfaces) by poking several holes with a pin, then apply thin CA glue and allow it to soak in and cure.

D 2. **Tack glue the Nylon Control Horns (NYLON03) in**

place on the rudder and elevator with a drop of thin CA. Use the plans as a reference for positioning the horns (Rudder on the **left**, elevator on the **bottom**). Drill two 3/32" holes through the control surfaces using the control horns as guides. Temporarily mount the horns with the 2-56 x 3/8" Screws (SCRW001) and the **Nylon Nutplates** which were attached to the horns,  2-56 X 3/8" Screw

D 3. Cut 4-1/4" off both threaded ends of the 36" Wire (WIRES 17) and then cut two pieces 12" long from the remaining piece of wire. Bend them as shown on the plans except without the Z-bends. The Z-bends are not bent until later. Wipe off each wire using a paper towel dampened with rubbing alcohol to remove any **oil**.

D 4. **Cut the pushrods from the 1/4" Square Balsa Sticks** (SPRTF09). The elevator pushrod should be 17-3/4" long and the rudder pushrod should be 15-1/4" long.

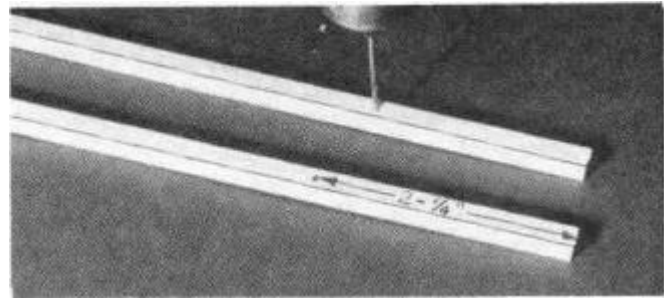

D 5. Drill a 5/64" hole 2-1/4" in from both ends of each pushrod.

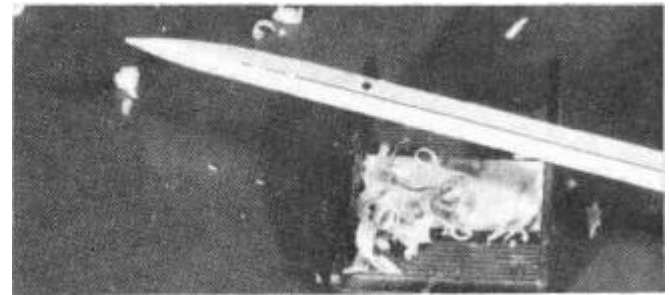

D 6. Use either a hobby knife, razor plane or coarse sandpaper to taper **three** sides on each end of both pushrods. The taper should start about 1-1/2" from the end. (One of the sides with the 1/16" holes should remain flat).

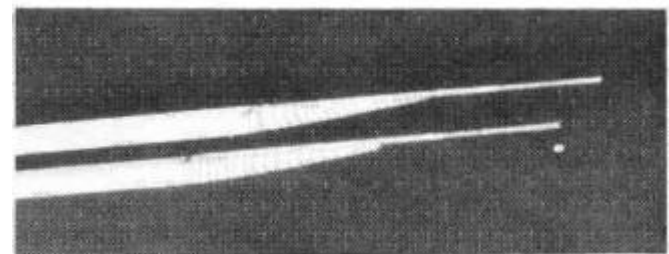

D 7. Insert one threaded piece of wire into each pushrod. Insert the 12" pieces of wire into the other end of each

pushrod. Tack glue the wires in place with a couple drops of CA. Firmly wrap the end of the pushrod with strong thread and apply thick CA to hold everything in place as shown on the plans and in the photo.

INSTALL RADIO GEAR

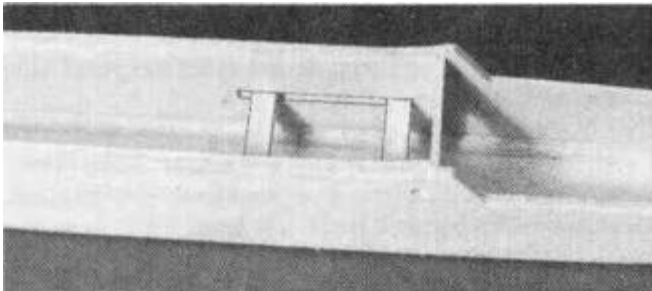

D 1. Slide one of the 1/4" x 3/8" **Basswood Servo Rails** (SPRTF11) into its slot in the fuselage doubler. Slide it all the way forward and glue it in place with thick CA. Slide the other servo rail into place and then slide it all the way to the back. **Do not glue it yet!** Position one of your servos in place and use it to position the rear servo rail. **Do not** push the rear servo rail up tight against the servo but rather leave about a 3/32" **gap** between the servo "body" and the rear servo rail. This will give you enough room to put the servos in and out without removing the rails. Glue the rear servo rail in place.

D 2. Position both of the servos together in the middle of the rails and mark where the holes for the servo mounting screws should be drilled. Remove the servos and drill 1/16" holes where the marks are. Install the servos, with the wires exiting forward, using the servo mounting screws that came with the radio.

D 3. Cut three "arms" off of two X-type servo horns using wire culling pliers or a razor saw as shown in the following sketch.

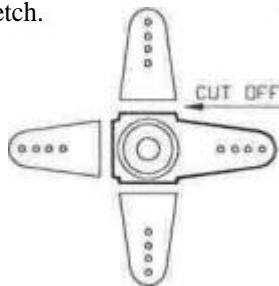

D 4. Read and follow the instructions that came with your radio to install or charge the batteries and get the servos ready for mounting. Plug the servos and the battery pack into the receiver and turn on the **transmitter first** and then the receiver. Adjust the trim levers to their neutral positions and allow the servos to return to their neutral positions. Install the

two servo horns you cut earlier with the arms facing opposite directions as shown on the plans. Operate the transmitter sticks to make sure the servo horns turn freely without hitting each other or the fuselage sides. If they do, cut or sand them until they will operate freely. Turn off the **receiver first** and then the transmitter.

D 5. Screw a **Nylon Clevis** (NYLON17) onto the threaded portion of each pushrod. Slide the pushrods into the fuselage. The rudder pushrod exits the top of the fuselage just in front and to the left of the fin. The elevator pushrod exits the hole in the rear of the fuselage. Snap the nylon clevises into the outermost hole in the servo horns. The rudder pushrod goes to the left servo and the elevator pushrod goes to the right servo. **With the control surfaces in their neutral position**, use a felt tip marker to make a small mark on each pushrod wire where they cross the holes in the control horns. Remove the pushrods from the fuselage and make a Z-bend in each wire with the first bend starting where the marks are.



(Airplane shown not covered, for reference)



D 6. Cut any excess wire off 1/4" past the Z-bend and reinsert the pushrods into the fuselage. Remove the nylon control horns from the elevator and rudder and install the horns onto the pushrods. Both pushrods should connect to the control horns through the second hole from the inside. Reinstall the control horns to the elevator and rudder. Adjust the nylon clevis or the bends in the wire until the control surfaces are at neutral when the servo horn is perpendicular to the centerline of the fuselage.

D 7. If you are installing spoilers, mount the spoiler servo between formers F3 and F4. It can be mounted on servo rails, or on its side with servo tape. Cut 3 arms off of an X-type servo horn as you did for the tail surfaces and mount a #2 x 3/8" (not included) screw in the outer hole. Adjust the servo and your transmitter so the horn is almost pointing towards the rear of the plane when your transmitter stick is in the "spoilers closed" position. The horn should rotate towards the front of the plane when the transmitter stick is moved to the "spoilers open" position. Which way the transmitter stick moves to open the spoilers is up to you. Both directions are used by today's pilots.

D 8. Pack the receiver in at least 1/4" of foam and install it in between formers F3 and F4. If you are installing spoilers, mount the receiver behind the rudder and elevator servos. The receiver antenna can run down through the fuselage but try to route it as far away from the servos and servo wires as possible. Allow the excess antenna to trail from the fuselage. **DO NOT CUT THE ANTENNA!**

D 9. The receiver switch can be taped to former F3 with double sided foam tape. Because the canopy is so easy to remove, there is no need for the switch to be accessible from the outside (this helps cut down on aerodynamic drag and accidental shut-offs during launching as well).

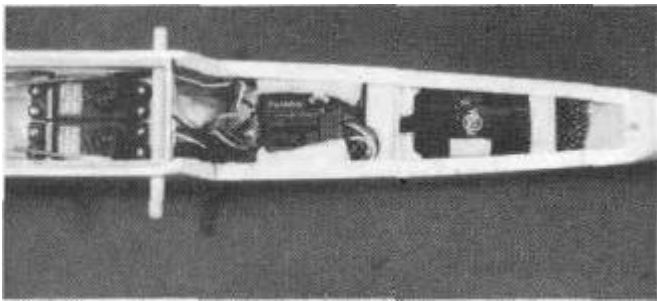

D 10. The battery pack should be wrapped in 1/4" of foam also and it should be positioned between formers F2 and F3.

D 11. Hook up your radio system and test the operation of all controls. The controls should move smoothly without any binding or looseness.

CONTROL THROWS

We recommend the following CONTROL SURFACE THROWS:

ELEVATOR: 1/2" up, 1/2" down

RUDDER: 1-1/2" Rt., 1-1/2" Lt

NOTE: Throws are measured at the **widest part** of the elevator and rudder. These control surface "throws" are approximate and provide a good starting point for the first flights with your SPIRIT. You may wish to change the throws slightly to provide the smoothness or quickness that you prefer.

Move the pushrod wires (Z-bends, nylon clevises) in or out on the control horns and servo horns to achieve the desired movements. If your radio is equipped with "endpoint adjustments" you may set the throws from the transmitter.

INSTALL THE SPOILERS IN THE WING (OPTIONAL)

D 1. Thread a 30" long piece of braided fishing line through the spoiler tubing in the wing.

D 2. Thread one end of the string through the small hole in the spoiler horn and use a piece of a round toothpick to hold the line in the horn. Allow about 1/2" to hang out the other side of the horn for fine adjustments.

D 3. Tape the spoiler in position in the wing using a strip of cellophane, vinyl tape or a strip of covering. The tape should be flexible enough to allow the spoiler to close on its own. **The tape should also be replaced every once in a while as it will eventually rip.**

D 4. Glue a small lead weight on the bottom side of the spoiler to help it close. 1/4 oz. is usually enough since the airflow will keep the spoilers closed when the plane is flying.

D 5. Mount the wings on the fuselage and pull the ends of the spoiler strings up to the spoiler servo. Position the spoiler servo horn at the rearward end of its swing and wrap one spoiler string around the screw in the horn. With the spoilers taped or held closed, apply a drop of thick CA to glue the string to itself and form a small loop. Remove that string and perform the same steps to the other string. The two strings should be the same length (be careful not to glue the two strings together) and the spoilers should open and close together. Small adjustments can be made at the toothpick end if needed.

BALANCE THE MODEL

NOTE: This section is **VERY important and must not be omitted!** A model that is not properly balanced will be unstable and possibly unflyable.

D 1. The balance point (CG-Center of Gravity) is shown on the plan, and is located under the spar. This is the balance point at which your model should balance for your first flights. Later, you may wish to shift the balance up to 3/8" **behind** the spar to change the flying characteristics. Moving the CG **forward** of the spar will add some stability but it will **decrease** the overall performance of the sailplane and make it stall easier at slower speeds. Moving the balance **behind** the spar makes the model more agile with a lighter and snappier "feel" and **improves** the sailplane's response to air currents. It also makes the model **less stable** and can cause the sailplane to "tuck under" or dive when its flying speed increases. If you fly the SPIRIT with its CG behind the spar (usually only contest flying), pay close attention and do not

let it gain excessive speed. If it does tuck under and you have plenty of altitude, give the plane a little down elevator and allow it to go on under. When it starts to climb up the back of the "outside loop" its airspeed will drop and you can pull out with some up elevator or roll out with full rudder. If you don't have plenty of altitude, gently pull out with up elevator but **be careful** and **don't "jerk"** it up or you may over stress the wing.

D 2. With the wing attached to the fuselage, and all parts of the model installed (ready to fly), lift the model by picking it up with a finger on each bottom inner spar. If the tail drops when you lift, the model is "tail heavy" and you must add weight to the nose to balance. If the nose drops, it is "nose heavy" and you must add weight to the tail to balance. The model should hang with a **slight** nose down attitude. Add BB's or lead to the weight compartment between formers F1 and F2 to correct a tail heavy model. In the unusual circumstance that you would have a nose heavy model, you can switch the receiver and battery or even move the receiver behind the servos. Getting the weight farther back helps correct the "nose heaviness".

FINAL HOOKUPS AND CHECKS

D 1. Attach the **4-40 Threaded Towhook** (WBNT148) to the bottom of the fuselage by threading a 4-40 Nut (NUTS002) and a #4 Washer (WSHR005) all the way onto the towhook and screwing the towhook into the front hole for the first flights. With the towhook threaded almost all the way into the blind nut, make sure the towhook is facing straight back and tighten the 4-40 nut to secure it. After the first flights the towhook can be moved back to the center hole for most flying conditions. For contest flying you may want to try the rear hole as it can help achieve a higher launch but **be careful** as the sailplane will be more apt to "Pop Off the line".

D 2. A piece of self adhesive foam rubber weather stripping can be applied to the front of the fuselage bottom to help protect it from getting nicked up during landings.

D 3. The canopy is held in place with a rubber band. Loop a medium size rubber band through the cut-out in the canopy back. Thread the rubber band through itself and then hook it on the little extension on former F4. To remove the canopy, pick up on the back until the front is clear of the dowel. To put the canopy back on Just do the opposite.

D 4. Make sure the control surfaces move in the proper direction as illustrated in the sketch to the right.

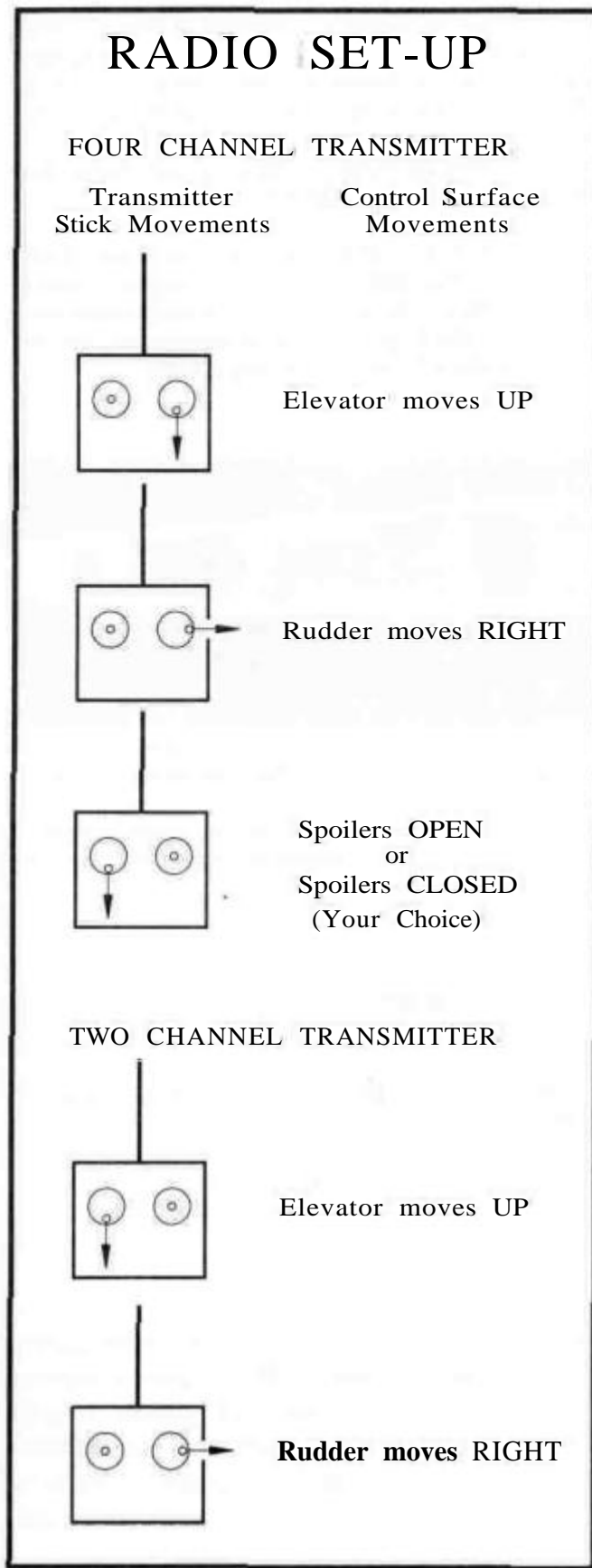

PRE-FLIGHT

CHARGE THE BATTERIES

Follow the battery charging procedures in your radio instruction manual. You should always charge your transmitter and receiver batteries the night before you go flying, and at other times as recommended by the radio manufacturer.

FIND A SAFE PLACE TO FLY

The best place to fly your R/C model is an AMA (Academy of Model Aeronautics) chartered club field. Ask your hobby shop dealer if there is such a club in your area and join. Club fields are set up for R/C flying which makes your outing safer and more enjoyable. The AMA can also tell you the name of a club in your area. We recommend that you join AMA and a local club so you can have a safe place to fly and also have insurance to cover you in case of a flying accident. (The AMA address is listed on the front cover of this instruction book).

If a club and its flying site are not available, you need to find a large, grassy area at least 6 miles away from any other R/C radio operation and away from houses, buildings and streets. A schoolyard may look inviting but it is usually too close to people, power lines and possible radio interference.

If you are not thoroughly familiar with the operation of R/C models, ask an experienced modeler to check to see that you have the radio installed correctly and that all the control surfaces do what they are supposed to.

RANGE CHECK YOUR RADIO

Wherever you do fly, you need to check the operation of the radio before every time you fly. This means with the transmitter antenna collapsed and the receiver and transmitter on, you should be able to walk at least 100 feet away from the model and still have control. Have someone help you. Have them stand by your model and, while you work the controls, tell you what the various control surfaces are doing.

INSTALL THE WINGS

If you built a two-piece wing it is a good idea to wrap the top of the center joint with a strip of vinyl tape. Rubber

band the wing to the fuselage using eight (8) #64 rubber bands.

If you built a bolt-on wing. Use two 1/4 - 20 nylon bolts to hold the wing in place. Cut the bolts to the proper length so they will not interfere with the controls inside the fuselage. Tighten the bolts so the wing is held firmly in place but do not over tighten.

AMA SAFETY CODE

Read and abide by the following Academy of Model Aeronautics Official Safety Code:

GENERAL

1. I will not fly my model aircraft in competition or in the presence of spectators until it has been proven to be airworthy by having been previously successfully flight tested.
2. I will not fly my model aircraft higher than approximately 400 feet within 3 miles of an airport without notifying the airport operator. I will give right of way to, and avoid flying in the proximity of full scale aircraft. Where necessary an observer shall be utilized to supervise flying to avoid having models fly in the proximity of full scale aircraft.
3. Where established, I will abide by the safety rules for the flying site I use, and I will not willfully and deliberately f

RADIO CONTROL

1. I will have completed a successful radio equipment ground check before the first flight of a new or repaired model.
2. I will not fly my model aircraft in the presence of spectators until I become a qualified flyer, unless assisted by an experienced helper.
3. I will perform my initial turn after **takeoff** away from the pit, spectator and parking areas, and I will not thereafter perform maneuvers, flights of any sort or landing approaches over a pit, spectator or parking area.

FLYING

First of all, if you are flying with other flyers check to make sure they are not flying or testing on the same frequency as your model.

Try to find an experienced pilot to help you with your first flights. Although the SPIRIT is very easy to fly, an experienced pilot can save you a lot of time and possible aggravation by helping you get your model in **the air** smoothly for the first couple of flights.

TRIM FLIGHTS

It is a good idea to do a couple of trim flights before each flying session to make sure the plane is still in trim and the radio is working properly. The model will survive a hard landing from 5 feet much better than it will one from several hundred feet. The first few trim flights should be done over a grass field. The longer the grass the better (more cushion).



Turn on the transmitter first and then the receiver and hold the SPIRIT under the wing with the nose pointed slightly down and directly into the wind as shown in the photo. It is very important that you launch the model with the wings level and the nose pointing at a spot on the ground about 50 feet in front of you. Have a friend stand off to the side of you and tell you whether the nose is pointing up or down. Show your friend the picture above so he will know what to look for. If the sailplane is launched with the nose up or launched too hard it will climb a few feet, stall and fall nose first straight

down. With the nose pointed down slightly the sailplane will accelerate down until it picks up enough flying speed then level off and glide forward. The plane should be launched with a gentle push forward. With a little practice you will be able to launch it just the right speed so it soars straight ahead in a long and impressive glide path. Adjust the trims on your transmitter to get the plane to fly straight ahead in a smooth glide path.

Once you get the hang of launching it you can try turning the plane during the trim flights by **gently** applying a "touch" of right or left rudder. You can also try "flaring" the landings by **slowly** applying a touch of up elevator (pull the stick back) as the plane nears the ground. The SPIRIT will continue to fly just a few inches off the ground for a surprisingly long distance. It is important you don't "over-control" the model. **Make any control inputs slowly and smoothly rather than moving the transmitter sticks abruptly.**

YOUR FIRST HI-START LAUNCH

A hi-start is the most popular way to launch your SPIRIT. It consists of 25'-100' of rubber tubing and 200' - 400' of string with a parachute or streamer at the end. One end of the rubber is staked down directly upwind of the launch point. One end of the string is attached to the other end of the rubber and the end of the string with the parachute has a loop or ring and is attached to the towhook on the sailplane.

TYPICAL HI-START LAUNCH

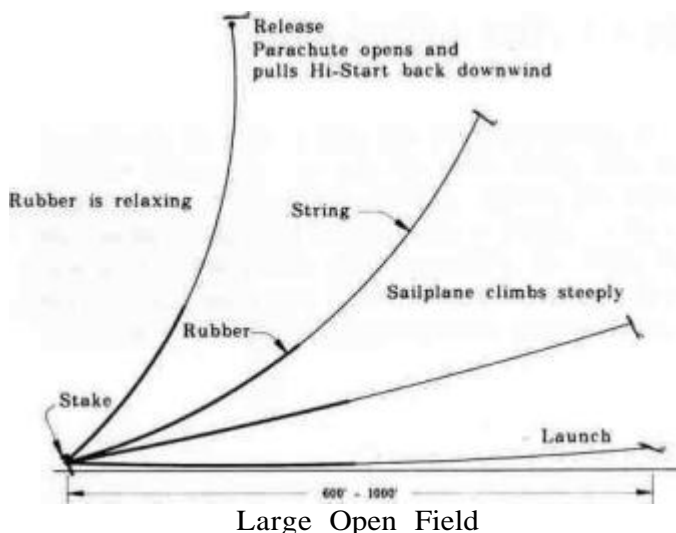

Follow the directions that came with the hi-start and lay it out directly into the wind. Place the stake at the far **upwind** edge of the flying field so the parachute will blow back onto the flying field.

Turn on your transmitter and then your receiver and hook the parachute up to your plane's towhook. Pull the plane back approximately twice as far as the rubber is long (ie. 100' of rubber = pull back 200') or whatever the hi-start instructions state. A "fish scale" is handy for determining the correct amount of pull. For your first flights pull the plane back until there is approximately 8 lbs. of tension. More tension can be used after you get acquainted with the launching procedure.

Hold the plane above your head with the wings level and the nose pointed slightly up and directly into the wind. Give the plane a healthy push forward to get it flying and it will climb up like a kite. You should not have to touch the elevator during the launch but use the rudder stick to keep it going straight up. As the rubber relaxes the plane will fly off the hi-start and the parachute will bring the end of the string back towards you.

FIRST FLIGHTS

Find a **BIG OPEN** field for your first flights. The bigger the better as you won't have to worry about where you need to land. Ground based objects (trees, poles, buildings, etc.) seem to attract model airplanes like a magnet. **Again, we would like to recommend you find an experienced pilot to help you with these first flights.**

NOTE: You need to remember that your radio control responds as if you were sitting in the cockpit. When you push the transmitter stick to the right, the rudder moves to the plane's right! This means that when the plane is flying towards you it may seem like the rudder controls are reversed (when you give "right" rudder the plane turns to your left-which is the planes "right") It is sometimes easier to learn to fly the plane if you always face your body in the direction the plane is flying and look over your shoulder to watch the model.

Don't worry about accomplishing very much on your first flights. Use these flights to get the "feel" of the controls and the SPIRIT'S flying characteristics. Try to keep the plane upwind and just perform some gentle "S" turns (always turning into the wind) until it is time to set up for landing. Have a helper adjust the trims on your transmitter (a little at a time) until the plane will fly straight and level with the transmitter sticks in their neutral positions. It can be very hard for a beginner to fly a plane straight towards him as he would have to do if the plane were downwind and every mistake takes the plane a little farther downwind. When it is time to land just continue performing the gentle S-turns upwind and let the plane glide onto the ground. Don't worry about where the plane lands, just miss any trees, etc.

Practice flying directly into the wind (upwind of yourself) without letting the plane get off course and then turn and come downwind until the plane is even with you and try it again. When you are comfortable with flying directly into the wind, start letting the plane go behind you (downwind) a little before you start back upwind. Continue this until you can fly directly towards you from downwind without getting disoriented. At this point you can start to establish a "landing pattern" and bring the sailplane in for a landing from downwind. This enables the plane to be flown as slowly (ground speed) as possible for accurate landings.

THERMAL FLYING

Thermal soaring is one of the most intriguing of all aspects of flying and the SPIRIT was designed to **excel** at thermal soaring even in the hands of a novice. It can be hard for the average person to understand how a plane can fly for hours and gain altitude **without a motor**. The following paragraphs and some flying time should help educate you about this unique style of flying.

FACTS ABOUT THERMALS

Thermals are a natural phenomenon that happen outside, by the millions, every single day of the year. Thermals are responsible for many things including forming several types of clouds, creating breezes, and distributing plant seeds and pollen. If you have ever seen a dust devil (which is nothing more than a thermal that has picked up some dust), you have seen a thermal in action. Their swirling action is very similar to that of a tornado's but of course much gentler. Most thermals have updrafts rising in the 200-700 feet per minute range but they have been known to produce updrafts of over

5,000 feet per minute (that's over 50 miles/hour straight up!) These strong thermals can rip a plane apart or carry the plane out of sight before the pilot can get out of the updraft

Thermals are formed by the uneven heating of the earth and buildings, etc. by the sun. The darker colored surfaces absorb heat faster than the lighter colors which reflect a great deal of the sun's energy back into space. These darker areas (plowed fields, asphalt parking lots, tar roofs, etc.) get warmer than the lighter areas (lakes, grassy fields, forests, etc.). This causes the air above the darker areas to be warmer than the air over the lighter areas and the more buoyant warm air rises as the cooler, denser air forces its way underneath the warmer air. As this warm air is forced upward it contacts the cooler air of the higher altitudes and this larger temperature difference makes the thermal rise quicker. The thermal is gradually cooled by the surrounding cooler air and its strength diminishes. Eventually the thermal stops rising and any moisture contained in the once warm air condenses and forms a puffy cumulus cloud. These clouds, which mark the tops of thermals, are usually between 2000 and 5000 feet high.

TYPICAL THERMAL

Wind causes thermal
to drift downwind

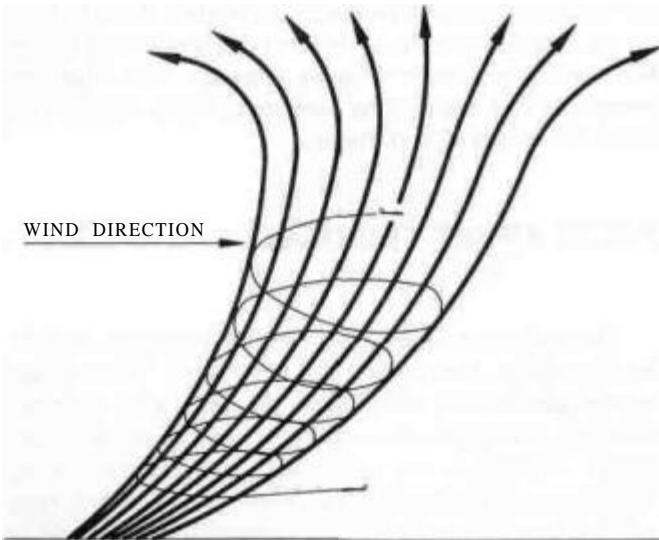

THERMAL SOARING

It takes a lot of concentration to thermal soar effectively. A sailplane can fly along the edge of a thermal and unless the pilot is carefully watching the model he may not realize the opportunity to gain some altitude. Because most thermals are relatively small (a couple hundred feet in diameter or less at 400' altitude.) compared to the rest of the sky, the sailplanes will rarely fly directly into the thermal and start rising. Generally, the sailplane will fly into the edge or near a thermal and the effects the thermal has on the plane may be **almost** unnoticeable. As the sailplane approaches a thermal, the wing tip that reaches the rising air first will be lifted before the opposite wing tip. This causes the plane to "bank" and turn away from where we would like the plane to go.

When you are thermal soaring, try to fly as **smoothly** and straight as possible. Trim the plane to fly in a straight line and **only** touch the controls when you have to. Watch the sailplane carefully and it will tell you what it is encountering.

When the sailplane flies directly into a thermal it will either start rising or stop sinking. Either case is reason enough to start circling (especially in a contest where every second counts). Fly straight ahead until you feel like you are in the strongest lift, **fly a couple of seconds farther** (so your circle will be centered in the strongest lift) and then start circling in a fairly tight but smooth turn. When the sailplane is low the turns have to be tighter to stay in the strongest lift. As the plane gains altitude, the turns can be larger and flatter. **The flatter the turn the more efficient the plane is flying**, but don't be afraid to really "crank" it into a steep bank when you are low. If you see the plane falling off on one side of the turn, move your circle over into the stronger lift. Thermals move along with the wind so as you circle you will be swept along with it. Be careful when thermaling that you don't get so far downwind you can't make it back to the field to land.

If the sailplane is flying along straight and all of a sudden turns, let the plane continue to bank (you may have to give it some rudder to keep it banking) until it has turned 270 degrees (3/4 of a full circle). Straighten out the bank and fly into whatever turned the plane. If you encounter lift, and you won't every time, start circling just as you did when flying directly into a thermal.

Thermals are generated all day long, but the strongest thermals are produced when the sun is directly overhead. 10:00 am - 2:00 pm seems to be the best time to get those "killer" thermals. Some of these thermals can be very large and you may find it hard to get out of them. If you find yourself getting too high, **don't dive** the plane to get out of the lift. Sailplanes are very efficient aircraft and they will build up a lot of speed and could "blow up" in the rough air of a thermal. The easiest way to lose altitude is to apply full rudder and full up elevator. This will put the plane into a tight

spin that will not over stress the airframe but it will enable it to lose altitude very quickly. This is especially helpful if the sailplane gets sucked into a cloud or it gets too high to see. The twirling action will give the sun a better chance of flashing off of the wing and catching your attention. When you are high enough and want to leave the thermal, add a little down trim to pick up some speed and fly 90 degrees to the direction of the wind. If you are not real high and want to find another thermal, you may want to look upwind of the last thermal. The same source that generated this thermal is probably producing another. Just watch out for "sink" it is often found behind and between thermals.

As you might expect, with all this air rising, there is also air sinking. This air is the sailplane pilot's nightmare that can really make soaring challenging. "Sink" is **usually** not as strong as the thermals in the same area, but it can be very strong. Down drafts of many hundreds of feet per minute are common on a good soaring day. These down drafts can make a sailplane look like it is falling out of the air. Because of this, it is important that you do not let the sailplane get too far downwind.

When encountering sink, immediately turn and fly 90 degrees to the direction of the wind (towards you if possible). Apply a little "down elevator" and pick up some speed to get out of the sink as fast as possible. **Every second you stay in the sink is precious altitude lost.**

POINTERS FOR CONTEST FLYING

Pay Attention! - Pay close attention to the sailplanes flying before you, watch them and try to establish where and when the thermals are being formed. Thermals are often formed in cycles and can be fairly regular so if you keep track of the time intervals you will have a pretty good idea of when and where a thermal may be generated.

Watch the birds! - Thermals suck up small insects that many birds love to eat. A bunch of swallows flying around in one area may indicate a thermal. Soaring birds (hawks, vultures, eagles etc.) are the best thermal indicators. They not only show you where the thermal is but they also show you where the center is. These "Masters of the sky" will often fly right along with sailplanes.

Practice those landings! - Most thermal contests are won or lost during the landing. Establish a particular landing pattern and try to stick to it for all landings. Learn to shift your pattern to account for the wind and particular flying field characteristics. Spoilers can be very useful during contest landings. They allow you to bring the sailplane in for a landing higher or faster than normal to guard against any last minute sink or

gusts and dump the extra altitude and speed at the last second. They can also be used to help control your skid. Opening the spoilers will stop the plane from sliding a little quicker. You can also "steer" the plane while it is sliding along the ground. Don't expect to be able to "horse it around" but you can gain valuable inches by using the rudder to guide it towards the spot as it slides to a stop. Be very careful not to "ground loop" the plane since you will lose your landing points if the plane flips over.

Concentrate! - Keep your eye on your sailplane during your contest flights. Have a helper or your spotter watch the other sailplanes in the air. Sometimes your sailplane will wiggle so quickly or gently that you may miss it if you are not paying close attention. If you find a productive thermal, don't leave it because your helper tells you that someone else has found a different one.

Know your sailplane! - Learn what your sailplane will and won't do and fly within this envelope. This will allow you to ride thermals downwind while knowing when you have to head back to make your landing safely.

Learn from the wind! - Keep track of which way the wind is blowing. If the wind suddenly shifts, there is some thermal action fairly close to you. The air is probably being either sucked up into a thermal or falling out of some sink. In either case it is often a good idea to fly in the direction the wind is blowing if your sailplane is in the general area. This will take you towards a thermal if there is one or away from the sink, both of which are desirable.

SLOPE SOARING

FLYING

Slope soaring is a type of flying that is very popular in hilly regions and along the coasts. This type of soaring is possible when the wind is blowing directly up a hill or cliff. As the wind hits the slope it is forced up producing lift which can be utilized by real sailplanes, hang gliders, birds and even model sailplanes.

To be able to slope soar, you need a slope with a smooth piece of land (or water) out in front of it and a breeze blowing pretty close to straight up the slope. The higher and steeper the hill or cliff the better. Also the larger and smoother the land out in front the better. The air flowing along hits the hill, is forced up and can generate a very large area of lift. Behind the hill is a large area of turbulent air that can be very dangerous to try to fly in. The faster the wind is blowing the stronger the lift and turbulence will be.

To fly off a slope, stand near the edge and throw the sailplane (nose down) into the wind. As the sailplane flies out into the "band*" of lift it will begin to gain altitude. Turn and fly parallel to the slope and make all of your turns into the wind (especially when you are close to the slope). You will be surprised at the altitude you can gain just from slope lift. Thermals will often be "popped loose" by these slopes. If you catch a thermal and follow it downwind, be very careful to stay high enough to make it back to the slope without flying through the turbulent air behind the slope. If you don't have enough altitude you may want to land a good distance behind the slope if possible to avoid this turbulent air.

SLOPE LANDINGS

Landings can be very tricky on some slopes. On gentle slopes you can often fly very close to the top of the slope and "slide" into the top of the slope without encountering any turbulent air. On steeper slopes you may have to be a little more aggressive to get the plane out of the lift. In any case it is a good idea to talk to the local flyers to plan your landing before you launch your plane.

POWERED LAUNCHING

Your SPIRIT can also be launched with either an electric motor or a fuel powered engine. "Power pods" are available for both electric motors and fuel powered engines and are easily mounted on top of the wing with rubber bands. These power pods will allow you to launch your SPIRIT from smaller fields than would be possible with a hi-start. They do however, cut down on the soaring performance of the sailplane due to their added weight and aerodynamic drag.

Since each power pod has its own set of instructions we will not explain their use any further here.

BALLASTING

In strong wind conditions, you may want to add ballast (weight) to the sailplane to increase its wing loading which increases its normal flying speed. Increasing the

weight of your sailplane does not directly change its "glide ratio" but it does make it fly faster which makes it sink a proportional amount faster. Because of this faster sink rate, you need to be very cautious when ballasting for a thermal contest. In duration type contests only use ballast on very windy days that also have a lot of thermal activity.

Add the weight as near as possible to the CG of the plane. 6-8 oz. will make a noticeable difference in the sailplane's flying speed and more can be added if needed. **Make sure to recheck the CG of the plane after adding ballast, it should remain where it was.**

Have a ball! But always stay in control and fly in a safe manner.

GOOD LUCK, WE HOPE YOU CATCH MANY THERMALS!

BUILDING NOTES

Kit Purchase Date: _____

Where Purchased: _____

Price: _____

8-Digit # on End Flap of Box: _____

Date Construction Started: _____

Date Construction Finished: _____

Date of First Flight: _____

Finished Weight: _____

Wing Loading (Weight ÷ 4.69): _____

Comments: _____

PARTS LIST

PART # QTY. DESCRIPTION

PACKED LOOSE IN KIT

CANPY044	1	SPIRIT Canopy
SPRTD01	1	SPIRIT Decal Sheet
SPRTF10	1	Shaped Balsa Nose Block
SPRTF12	1	ABS Formed Cockpit
SPRTP01	1	Full Size Plan Sheet
SPRTP02	1	Instruction Book
SPRTW15	2	Tapered Balsa Wing Tip Block
WIRES 10	1	36" Wire W/ Threaded Ends
ALUM010	1	Aluminum Wing Joiner

SUB-PACK DIE-CUT FUSE PARTS

(SPRTA01)

SPRTF01	2	3/32" Balsa Fuselage Sides, Wing Saddle Tripler
SPRTF02	2	3/32" Balsa Fuselage Doublers
SPRTF03	1	1/8" Plywood Front Fuselage Bottom
SPRTF04	1	3/32" Balsa Rear Fuselage Sheeting

SUB-PACK DIE-CUT WING RIBS (SPRTA02)

SPRTW01	1	1/8" Balsa Ribs 1A,1B,3A,3B
SPRTW02	2	1/16" Balsa Ribs 2, 2S
SPRTW03	2	1/16" Balsa Ribs 2, 4-10
SPRTW07	2	1/16" Balsa Shear Webs

SUB-PACK MISC. DIE-CUT SHEETS

(SPRTA03)

SPRTF05	1	1/8" Plywood Formers and Canopy Ends
SPRTF06	1	1/8" Balsa Canopy Base
SPRTS01	1	3/16" Balsa Tail Pans
SPRTW04	1	1/8" Plywood Dihedral Braces
SPRTW05	1	1/16" Plywood Wing Joiners, Towhook Plate, Spoiler Horn
SPRTW06	1	1/32" Plywood Polyhedral Braces
SPRTW08	1	1/8" Plywood Clamps and Gauges

SUB-PACK LONG STICKS fSPRTA04)

SPRTF07	4	1/8" Square x 24" Balsa Stringer
---------	---	-------------------------------------

PART # QTY. DESCRIPTION

SUB-PACK LONG STICKS (Cont.)

SPRTF08	2	3/16" x 24" Balsa Triangle
SPRTF09	2	1/4" Square x 18" Balsa Pushrod
SPRTS02	3	3/16" x 3/8" x 30" Balsa Tail Frame
SPRTS03	2	1/8" x 3/16" x 30" Balsa
SPRTW13	4	1/8" x 5/16" x 23-1/2" Bass- wood Inner Spar
SPRTW14	4	1/8" x 5/16" x 15-1/8" Bass- wood Outer Spar

SUB-PACK L.E. / T.E. / ELEVATOR / WING

SHEETING (SPRTA06)

SPRTS04	1	3/16" x 1-1/2" Tapered Balsa Elevator
SPRTW10	1	Shaped Balsa Leading Edges
SPRTW 11	2	1/4" x 1-1/4" Tapered, Notched Inner Wing T.E.
SPRTW12	2	1/4" x 1-1/4" Tapered. Notched Outer Wing T.E.
SPRTW17	3	1/16" x 3 x 30" Balsa Wing Sheeting

SUB-PACK HARDWARE AND SMALL

PARTS (SPRTM01)

DOWEL030	2	1/4" x 3-1/2" Hardwood Wing Dowel
DOWEL033	1	1/8" x 1-1/4" Canopy Hold Down Dowel
NUTS001	3	4-40 Blind Nut
NUTS002	1	4-40 Hex Nut
NYLON03	2	Small Nylon Control Horn and Nutplate
NYLON09	1	Nylon Hinges (12 per Tree)
NYLON17	2	Nylon Clevis
SCRW001	4	2-56 x 3/8" Machine Screw
SPRTF11	2	1/4" x 3/8" x 2" Basswood Servo Rail
WBNT148	1	4-40 Threaded Towhook
WSHR005	1	#4 Flat Washer

2 - VIEW DRAWING

Use this drawing to plan your trim scheme

