

# SEAHAWK



by ANDY LENNON

## Fly off land or water



PHOTOS BY ANDY LENNON

**T**HE SEAHAWK IS an older big brother of the Swift (which, as of this writing—late May '92—is being very successfully flight-tested). There is a distinct family resemblance.

The Seahawk may be easily and quickly converted from tricycle landing gear to central and wing-tip floats for water flying. The low-wing configuration permits this change. The horizontal tail is in a conventional location.

### SEAHAWK FEATURES

The wing incorporates the NASA safe wing modification (*Model Airplane News*, June 1990) and features Youngman flaps. These are similar to Fowler flaps, but are actuated by two pairs of arms for each flap. They increase the wing's area by 102 square inches and have a coefficient of lift maximum of 2.60 for the area of the wing that is flapped. The basic airfoil section of the Eppler 197, which I'm using on the Swift, has a maximum coefficient of lift of 1.17.

The Youngman flap was a British development and was used on the Fairey Firefly and Gannet, both British naval aircraft. Extension of the Seahawk's big, slotted flaps requires a powerful servo. The Futaba servo S131S with 69.5 ounce/inches of torque proved adequate, provided the model was slowed down at low rpm and in a slight climb. It has since been replaced by a Futaba S125 sail servo of 129 ounce/inches of torque. Flaps extended, landing speeds are in the low 20s in mph. One very pleasing characteristic is that the model noses down gently on flap extension. The nose-down pitch of the deployed flaps must exceed the nose-up pitch generated by the increase in the angle of downwash impacting on the horizontal tail.



### SPECIFICATIONS

- Wing span: 64 inches
- Wing area: 655 square inches (4.54 square feet)
- Gross weight: Land—110 ounces; water—121 ounces
- Wing loadings: Land—24.3 ounces/square feet; water—26.6 ounces/square feet
- Engine: O.S\* Max .46 SF
- Prop: 11x8 APC
- Power loadings: Land—239.9 ounces/cubic inches displacement; water—263 ounces/cubic inches displacement
- Central float beam loading: 3.36 ounces/square inches
- Sections: Wing—Eppler E197; Tail—Eppler E168
- Flap area: 102 square inches
- Flap type: Youngman flap

This model's structure is based on the principles outlined in the recent articles on stressed-skin design (see the September and October '92 issues of *Model Airplane News*).

The design of the central and wing-tip floats are detailed in *RCM* articles on hull and float design, (February, March and April 1991). The central float is based on the short after-body hull, with a stern-post angle of 8 degrees. Its beam is 6 inches at its widest point.

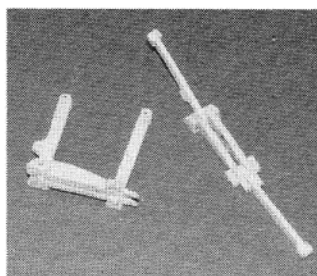

1. Two sets of flap arms.

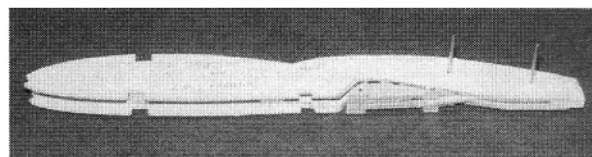

2. Flap-support ribs and fairings showing the flap retracted.

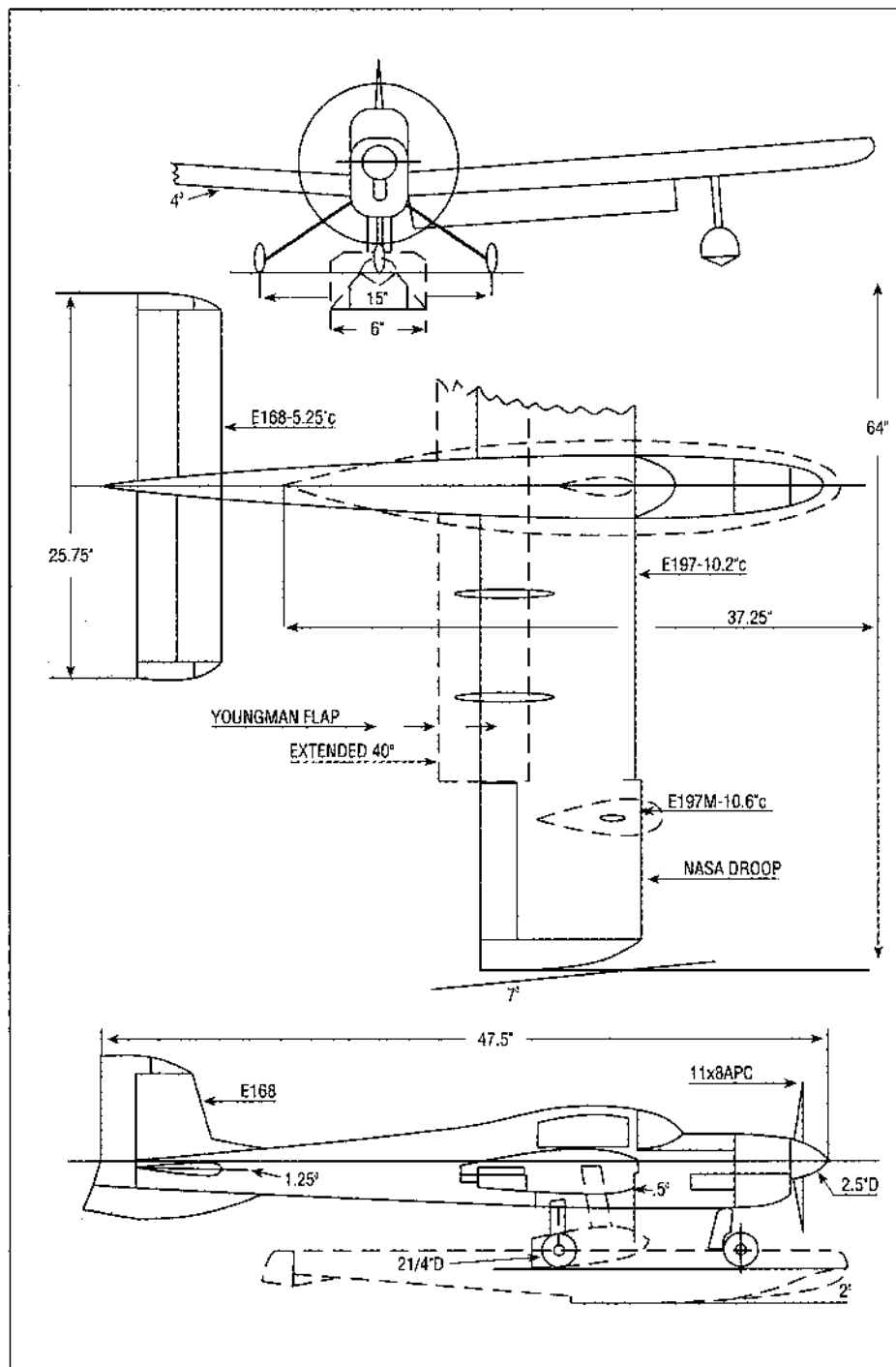

### CONSTRUCTION

This isn't a beginner's model. For a reasonably experienced modeler, the drawings and photographs provide ample detail for "kitting" the various metal, plastic, plywood and

**The Seahawk may be easily and quickly converted from tricycle landing gear to central and wing-tip floats for water flying.**

balsa sheet, strip and block parts.

The following focuses on assembly procedures and sequence. For example, the 1/8-inch brass tube on the elevator's 3/32-inch wire horn should be slipped onto the wire before making the second bend, for obvious reasons. Let's start with assembly of the component parts of the Youngman flaps.

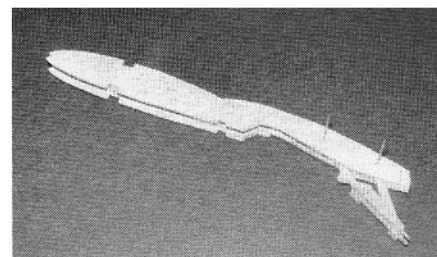

3. Flaps extended, showing flap action.

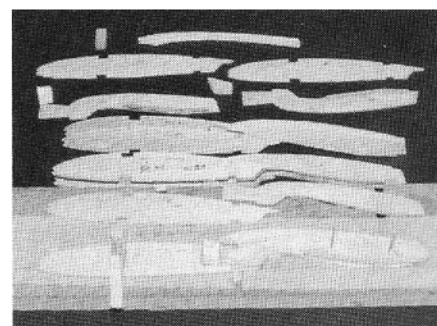

4. The flap-support rib-assembly jig and component parts and assemblies.

### YOUNGMAN FLAPS

Start by assembling four sets of ply arms and flap ribs as shown in the drawings and in photo 1. Four sets of support ribs are

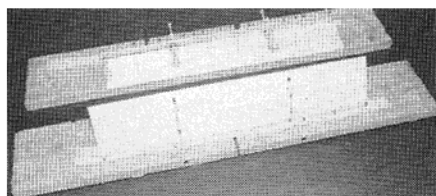

5. Flap assembly in progress.

needed. Photos 2 and 3 illustrate how the arms and supports function as the flaps are extended. Photo 4 shows the jig for these assemblies; note the two completed assemblies and various components. Accurate location or pivots is essential.

Photo 5 shows the assembly of flap skins, ribs and arms. The upper skin leading edges have been glued to those of the lower skins.

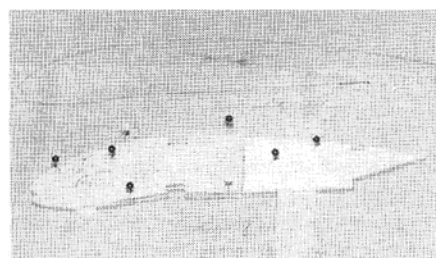

6. Rib I—assembly fixture

The strip of plastic film under the leading edges will help you avoid cementing the flaps to the base. Soften the top surface of the upper skins with liquid ammonia, and carefully glue the skins to the ribs and lower skin trailing edge. Sand the flaps to the dimensions of the drawing.

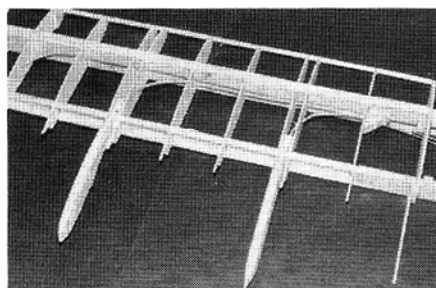

7. The unskinned wing structure showing flap and aileron cable sheaths installed.

**WINGS**

In addition to the four sets of flap-support ribs (photo 4), other sub-assemblies precede wing assembly. These are rib H, rib A and rib I, forming the wing-tip, float-strut sockets in photo 6.

The flap-support ribs in photo 7 position the flaps in relation to the wing itself. Carefully use the flaps for this purpose. Photo 7 also shows the cable plastic sheaths for aileron and flap in the left wing panel.

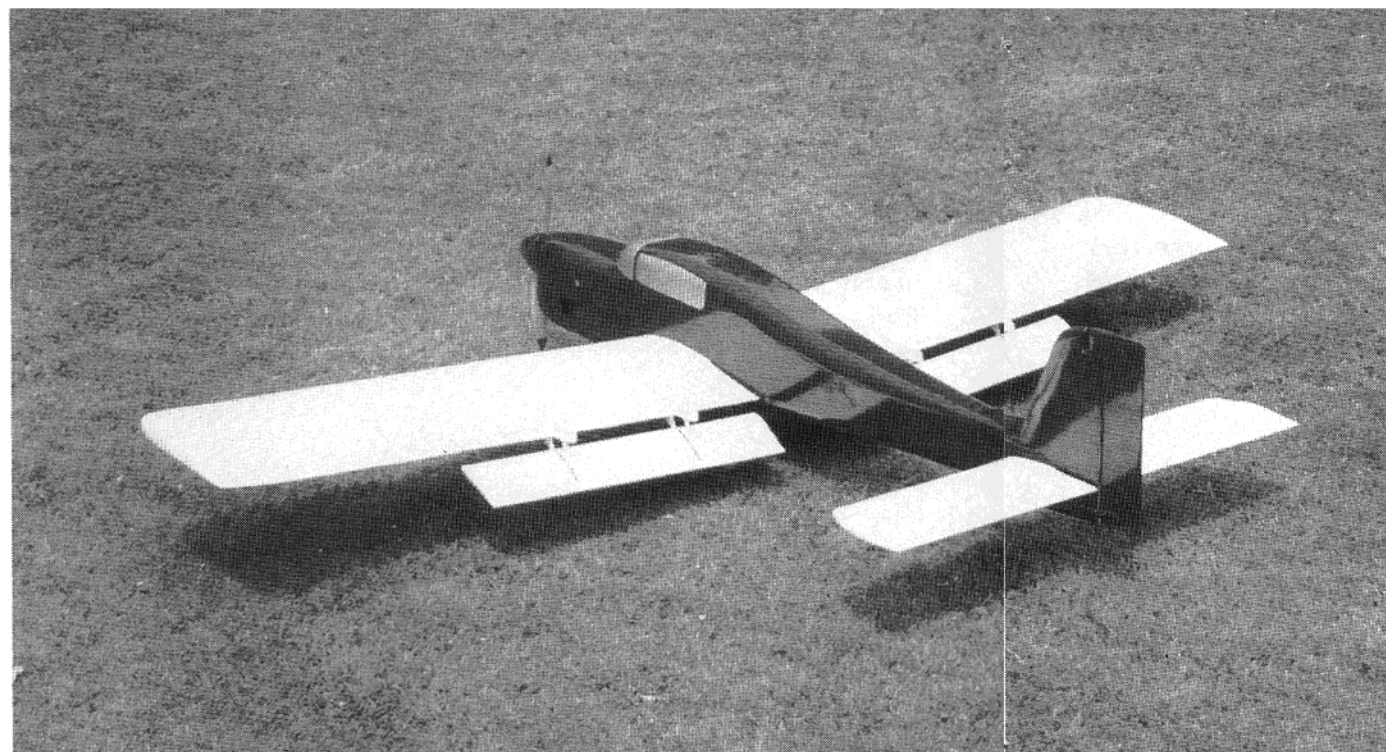

Youngman flaps fully extended. These add 102 square inches to the wing area.

These sheaths should be bent over a candle flame or heat gun so as to produce smooth, uninked curves before installation (see drawing). Similarly, the Sullivan\* steel cables should be bent, as shown on the drawing, before installation. Silicone lubricant squirted into the sheaths will reduce friction substantially. In photo 7, note the sheath guides and balsa-and-ply webs on the spars.

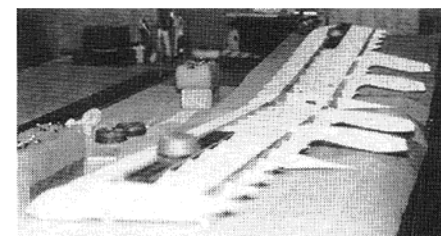

8. The wing-assembly fixture. The 1/4-inch-square balsa strips beneath the spars provide support.

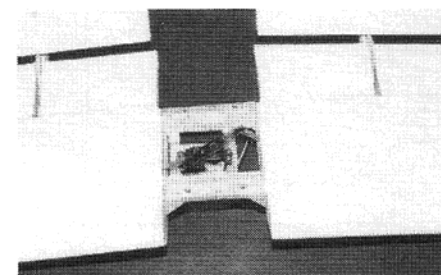

9. Center section, showing special flap servo arm and flaps extended, viewed from below.

This panel is ready to be skinned. Photo 8 portrays the wing-assembly fixture. This is composed of three pieces of pressed-wood shelving; two are angled at the wing's dihedral of 4 degrees.

The drawings, lightly rubber-cemented to the shelving, ensure proper positioning of the spars and ribs. The 1/4-inch-square balsa strips run spanwise under the spars as in photo 8. Raise them above the surface as shown.

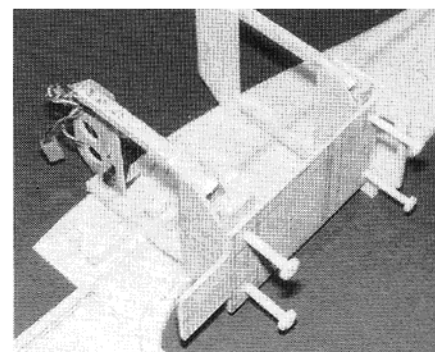

10. Bulkheads no. 4 and 5 showing wing landing gear and fuselage attachment.

Photo 9 shows the completed wing with servos installed and flaps extended. The special flap horn shows. Note that the rear arm of this horn is 5/32 inch longer than the one in front. This provides equal flap movement. (See drawing Plate 2.)

**FUSELAGE**

Sub-assemblies for the fuselage are:

- Bulkhead no. 1 with nose-wheel brackets bolted on the back and the motor mount bolted in front.

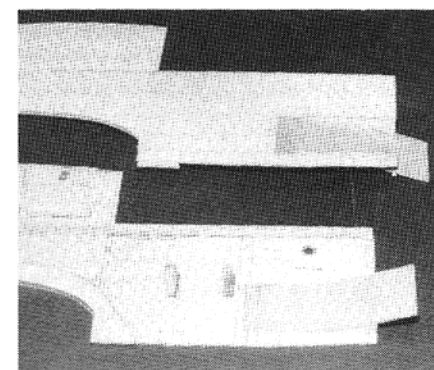

11. Details of cooling outlets in fuselage sides.

- Bulkheads 2, 3, 5, 6, 7 and 8 as per drawings, Plate 1.
- Bulkhead no. 4 and the receiver on-off switch.

Photo 10 shows the positioning of bulkheads 4 and 5 so that bolt holes in the bulkheads, wing mounts and landing-gear or float mounts will be correctly aligned. Note the over-wing doubler and 1/4-inch-square balsa servo rail mounts.

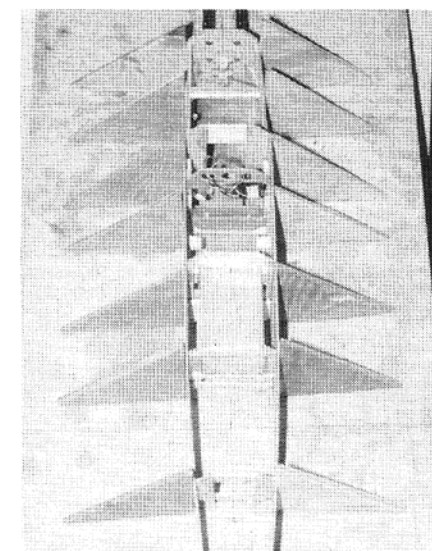

12. Fuselage-assembly fixture. The receiver and battery box are installed.

Photo 11 shows the side-skin sub-assemblies—cooling air outlets, a ply servo mount for the engine and a hole for the glow-plug heating jack.

Photo 12 is of the fuselage assembly jig with bulkheads, side skins and battery-receiver box installed.

While the frame is in the fixture in photo 12, install elevator and rudder cable sheaths.

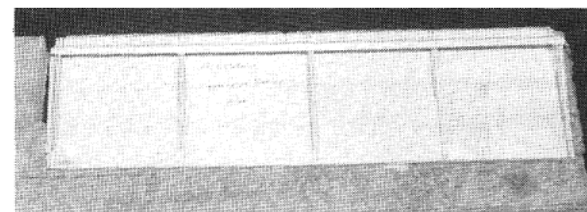

13. Aileron assembly in progress—typical.

ply servo rails, and receiver and battery. Run the aerial through the 1/8-inch-diameter holes in bulkheads. It will end up in the fin.

Add top and bottom skins; corners are last. See Plate 3 (and photo 19) for corner treatment.

**CONTROL AND TAIL SURFACES**

Photo 13 shows typical construction of ailerons, elevators and rudder. Note that a ply rudder horn is used.



14. Elevators and stab taped together ready for MonoKote covering.

The vertical fin is best installed on the fuselage. Take care to thread the radio's aerial through the holes in the fin ribs. Align the fin vertically, add side skins and dorsal fin block, and sand to conform to the drawing. The stab is assembled on a flat surface, top skin down. Use 3/4-inch triangular stock strip to raise the leading edge to conform to the rib contours. Add spars, ribs and top skin. Photo 14 shows the horizontal tail

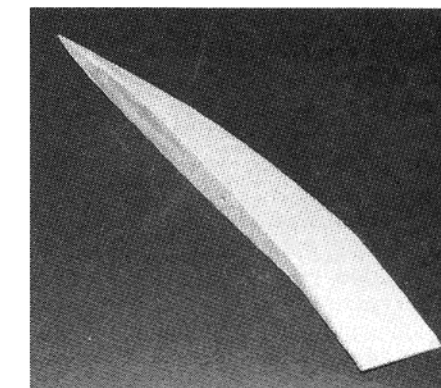

15. The detachable ventral fin used for water flying. The 3/16-inch D dowels haven't been installed.

plane with elevators masking-taped in position ready for MonoKote\* covering and elevator hinging. Plate 3 provides the hinging/covering sequence. It's recommended that you cover this assembly before you install it in the fuselage.

Photo 15 details construction of the ventral fin. It's easily installed for water flying and provides directional stability for flying on floats. The 3/16-inch diameter dowels haven't been installed in these photos.

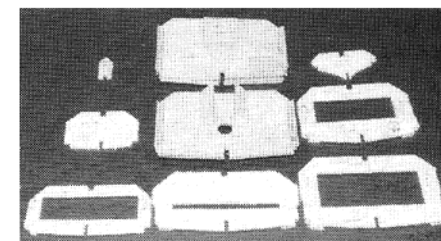

16. Central float bulkheads.

The "double" aileron servo horn shown on Plate 2 provides a 2:1 differential. The upgoing aileron moves much more than the downgoing, eliminating adverse aileron yaw. Use of rudder for turns isn't needed.

**CENTRAL AND WING-TIP FLOATS**

Photo 16 is of the central float bulkheads.

# SEAHAWK

Bulkhead nos. 2 to 7 are sub-assemblies; nos. 1 to 9 are balsa sheet.

Assemble the central float as depicted in photo 17. At this point, install the water-rudder ply servo mount, the servo, and the sheath and cable from servo to water rudder horn. Add top skins, 1/4-inch-square balsa chin strips, keels and bottom skins. Nose and stern blocks are then installed and shaped. Water rudder and hinge are glued with CA.

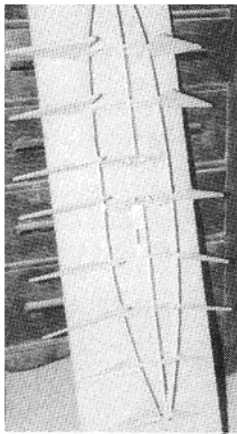

17. Central float assembly fixture—the water-rudder ply servo mount shows.

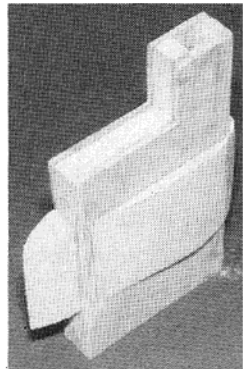

18. The assembled and shaped float strut. The raised portion has been deleted from the drawings.

Photo 18 portrays the assembled and shaped float strut. The upper forward turret has been deleted from the Plate 3 drawings as unnecessary. Note the servo-cable channel. This unit is to be installed in the "in-fuselage" mount—but not in the float until last.

Photo 19

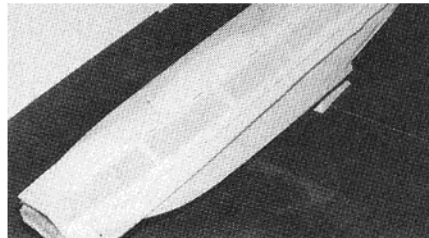

19. Tracing paper pinned to the float-top corner and marked to show outline for 3/16-inch-thick corner sheeting.

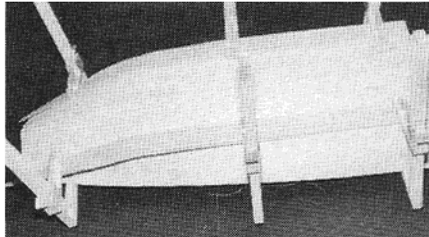

20. Chine flare spray strips are clamped to the forebody bottom while cement sets.

shows how to obtain the outline of the float upper 3/16-inch-balsa corner strips using transparent paper. The procedure for assembling these strips, for both fuselage and

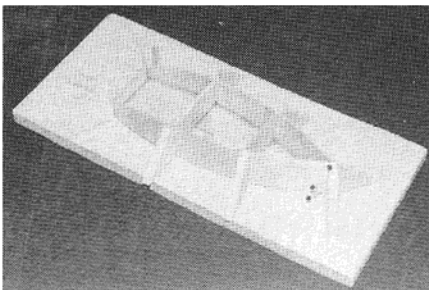

21. Wing-tip float-assembly fixture.

float, is given on Plate 3.

Photo 20 shows the chine flare spray strips clamped in position while the cement is setting up. Photo 21 is of the wing-tip float assembly. Top and bottom sheeting is applied next. Top and nose blocks are then added and shaped.

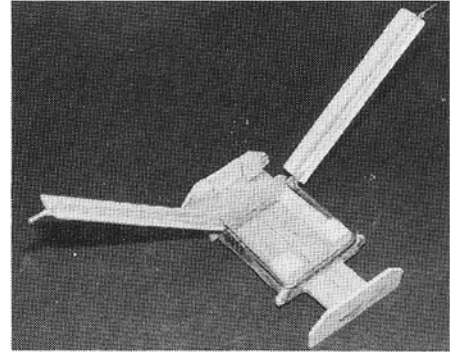

22. Main landing gear installed. Note bolting blocks.

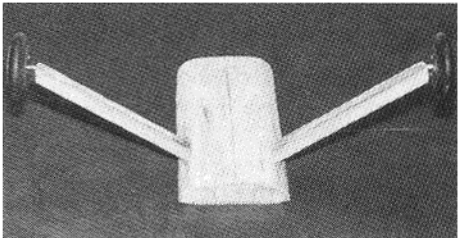

23. The completed main landing-gear assembly.

## LANDING GEAR

The 5/32-inch-diameter music-wire landing-gear legs have fairings shaped to streamline the cross section. The U-bend in the nose-wheel leg is replaced by a coil as shown in

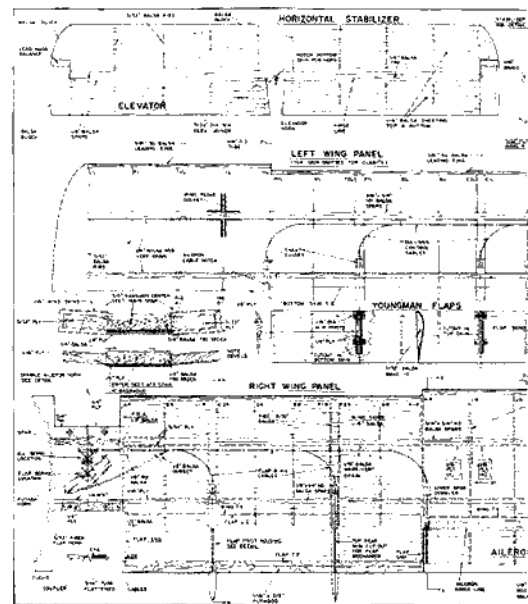
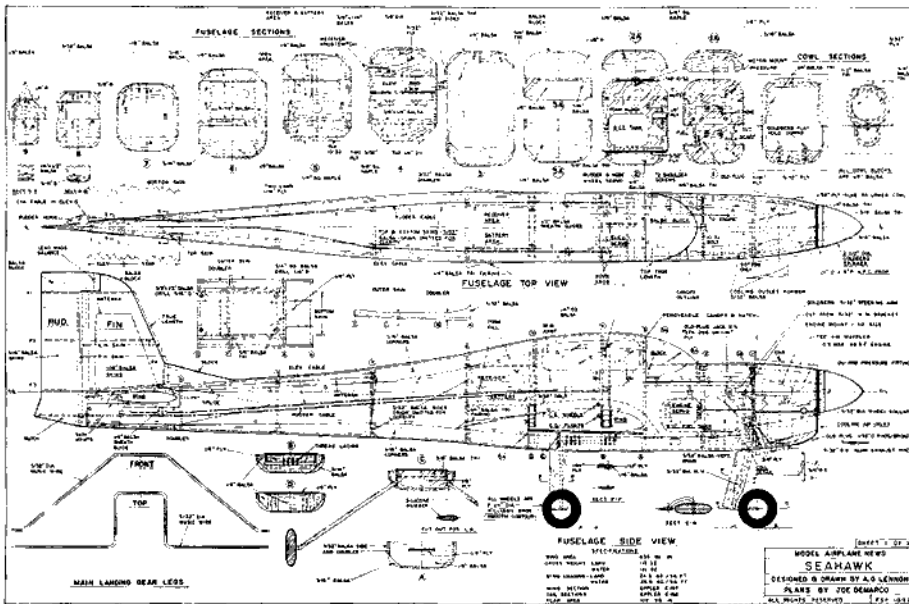
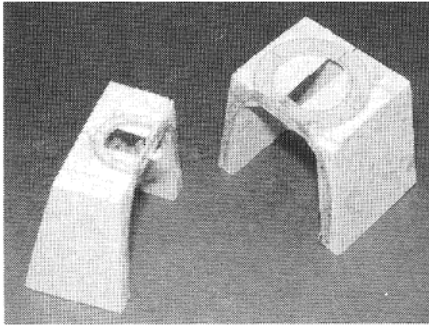

Plate 1 of the drawings and will prove more rugged.

Photo 22 shows the main-gear installation in the "in-fuselage" landing-gear mount. Note the four balsa bolting blocks. Photo 23 shows the finished main landing-gear assembly.

The float strut is assembled into a similar structure as detailed on Plate 3. For water flying, the central float assembly replaces



24. The cowl sub-assemblies ready for shaping inside and out.

the main landing-gear assembly; the nose-wheel gear is removed by loosening the steering-arm screw, and the ventral fin is plugged into position.

### ENGINE COWL

Photo 24 is of the 1/2-inch balsa sheet and ply parts assembly; the lower portion is hollowed out. In photo 25, the cowl has been tack-glued to the fuselage and shaped and sanded to fit the drawing. An old 2 1/2-inch-diameter spinner backplate guides the shaping of the ply spinner ring. The engine was installed at this point.

On final assembly, the upper cowl is glued

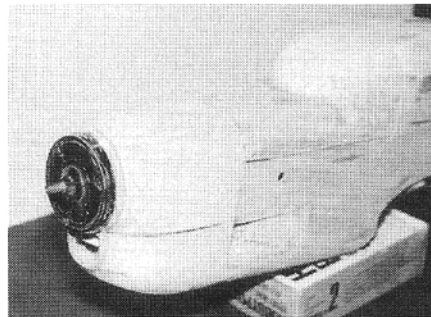

25. The cowling tack-glued to the fuselage for external shaping and sanding. An old, 2 1/2-inch-diameter spinner backplate is useful.

with CA to bulkhead no. 1 as shown on Plate 1. Install 3/32-inch ply with two Goldberg\* hold-downs to the lower cowl to hold the rear lower cowl. Photo 24 shows the single, front, flat hold-down in position.

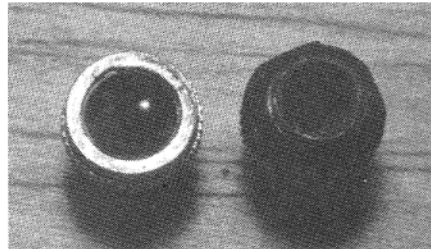

26. A 5/32-inch steel ball in screened half of two-piece aluminum fuel-line filter.

### CONTROL-SURFACE BALANCING

As the drawings show, the ailerons, the elevators and the air rudder are mass-balanced by weights (lead sheet or wire) ahead of the hinge line. This technique brings the surfaces' CG to the hinge line and prevents

potentially damaging flutter. (It's a full-scale practice).

The Seahawk is very clean aerodynamically and can achieve very high speeds in diving. This author has used surface mass balancing on many fast models—with no flutter. It's inexpensive insurance.

### CG LOCATION

Plate 1 shows the CG location at 25 percent of the wing's mean aerodynamic chord. Add ballast as required to achieve this CG location.

### ENGINE STARTING

To avoid lower cowl removal, and for safety, the glow plug is energized by a plug wired to the external power source and inserted in a jack situated well away from that dangerous rotating prop as shown on Plate 1 and in photo 27.

Starting the engine with the model inverted on your field box brings the engine upright for easier starting and avoids hydraulic lock that may occur when starting an inverted engine. Fuel and oil trapped above the cylinder head and under the piston can result in engine damage

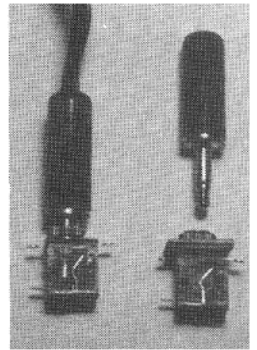

27. Jack and plug for glow-plug heating. Jack is well away from the dangerous prop. Radio Shack No. Jack 274-296, Plug 274-286

(Continued on page 105)

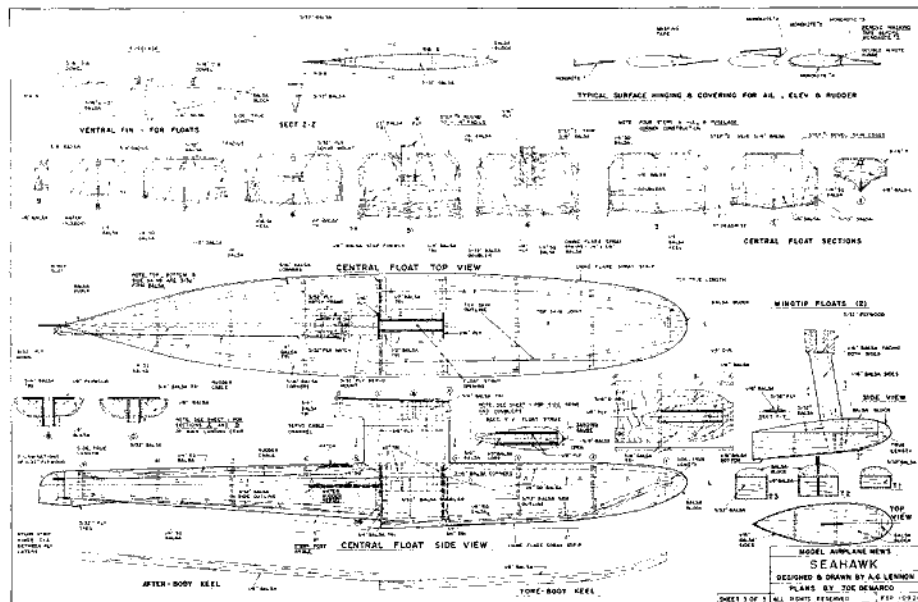
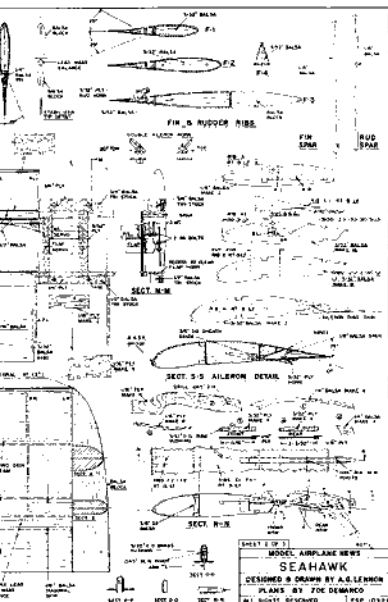

ORDER THE FULL SIZE PLANS ON PAGE 114

will fall into the unscreened half of the filter, preventing fuel from flowing into the muffler. Ball bearings are stocked by most bicycle shops. Mine cost a nickel each.

## **FLYING**

Here's where the fun begins! The Seahawk is fast, stable, yet responsive. Flaps aren't needed for takeoffs—both land and water; and the model has demonstrated knife-edge flight capability with wheeled landing gear.

Use low rates on aileron and elevator for high-speed flight, and high rate if flaps are down. On a very windy day, land flaps up. On calm days, flaps are almost mandatory, unless water-flying. The glide is so shallow, flap up, that it's easy to overshoot the runway. With flaps down, engine idling, very steep, slow approaches are possible. Happy one-piece landings.

*\*Here are the addresses of the companies mentioned in this article:*

*Sullivan Products, P.O. Box 5166, Baltimore, MD 21224.*

*MonoKote/Great Planes Model Distributors, P.O. Box 9021, Champaign, IL 61826.*

*Carl Goldberg Models, 4734 West Chicago Ave., Chicago, IL 60651.*

*O.S./Great Planes Model Distributors.* ■