

PIPER

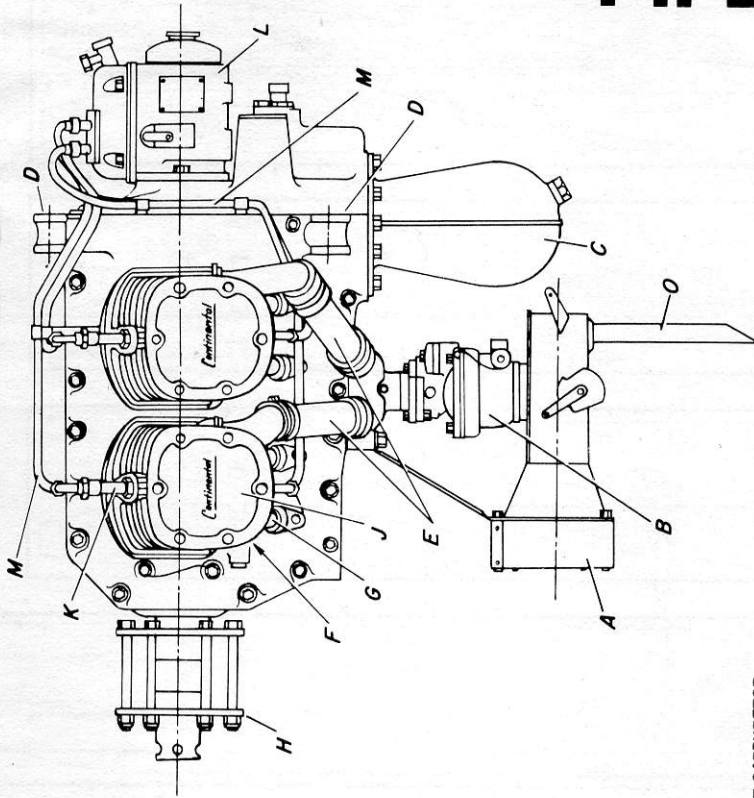

SPECIFICATIONS

HORSEPOWER	65 (2300 R.P.M.)
TYPE	AIR COOLED, HORIZONTAL OPP.
BORE	3.875"
STROKE	3.625"
DISPLACEMENT	171 CU. INCHES
NORMAL R.P.M.	2150 (CRUISING)
COMPRESSION RATIO	6.3:1



SIDE VIEW



SCALE IN FEET

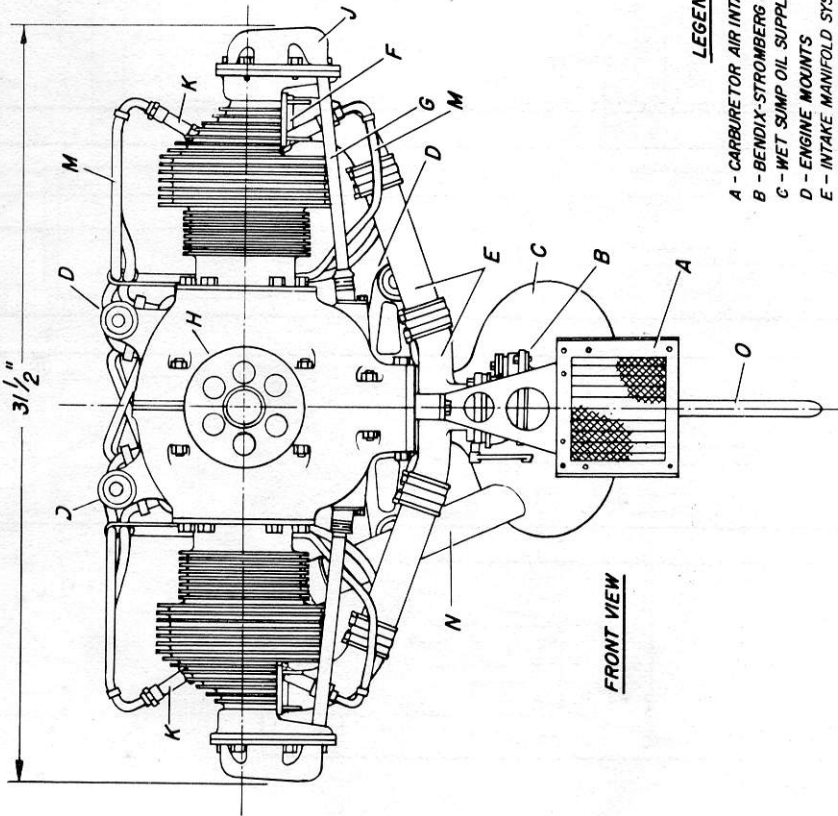

FRONT VIEW

LEGEND

- A - CARBURETOR AIR INTAKE
- B - BENDIX-STROMBERG UPDRAFT CARBURETOR
- G - WET SUMP OIL SUPPLY - 4 QTS.
- D - ENGINE MOUNTS
- E - INTAKE MANIFOLD SYSTEM
- F - EXHAUST PORTS (MANIFOLDS NOT SHOWN)
- G - VALVE PUSH RODS
- H - PROPELLER HUB
- J - VALVE COVERS
- K - SPARK PLUGS (2 PER CYLINDER)
- L - EISEMANN AM-4 MAGNETOS (2)
- M - IGNITION HARNESS
- N - OIL TANK FILLER NECK
- O - VENT

NOTE - THE CONTINENTAL A-65, 65 HORSEPOWER ENGINE IS ONE OF THE MOST POPULAR LIGHT AIRCRAFT ENGINES EVER MADE. THIS ENGINE AND ITS 50, 75 AND 80 H.P. COUNTERPARTS - ALL VERY SIMILAR IN APPEARANCE - ARE PROBABLY BEST KNOWN FOR THEIR DEPENDABILITY AS USED IN THE MOST POPULAR PIPER AND AERONCA LIGHTPLANES (AS WELL AS MANY OTHERS) FOR OVER TWENTY YEARS.

CONTINENTAL MOTORS CORPORATION
AIRCRAFT ENGINE DIVISION
MUSKEGON, MICH.

CONTINENTAL A-65-8

IDENTIFICEER DE UITGEKAPTE ONDERDELEN ALVORENS MET DE BOUW VAN UW J-3 TE BEGINNEN.

IDENTIFIEZ LES PIÈCES ESTAMPÉES AVANT D'ENTAMER LA CONSTRUCTION DE VOTRE J-3.

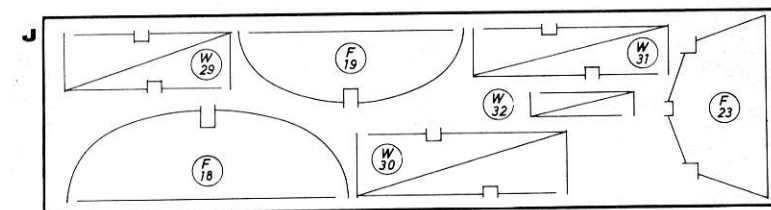
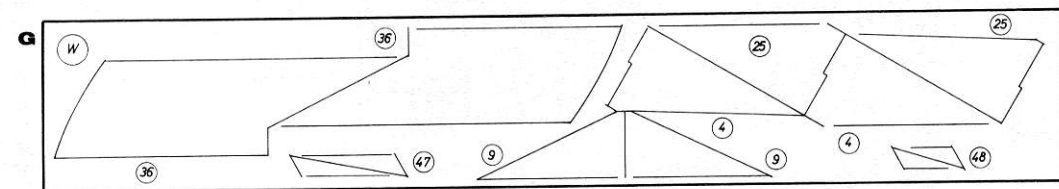
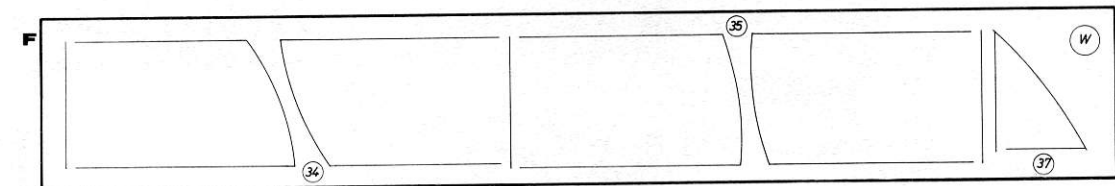
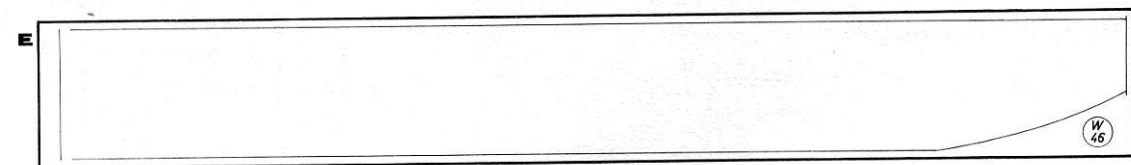
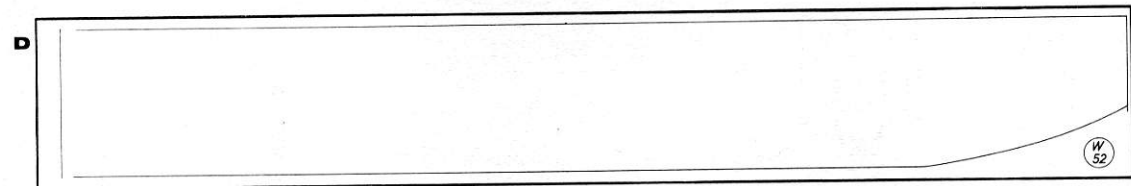
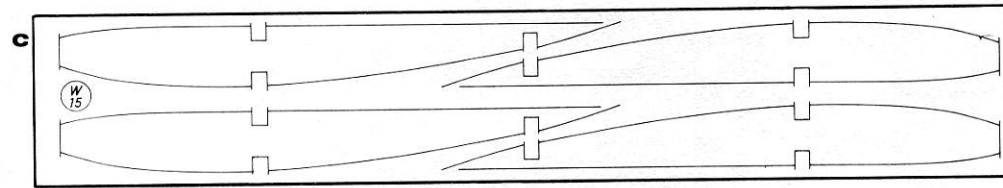
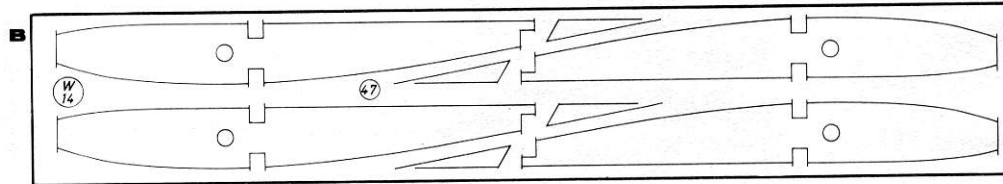
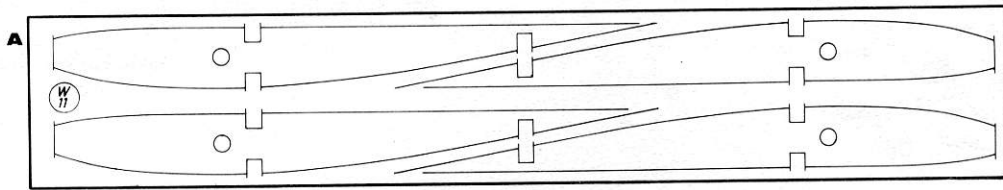

IDENTIFIZIEREN SIE DIE GESTANZTE TEILE BEVOR SIE MIT DEM BAU ANFANGEN.

IDENTIFY YOUR DIE-CUT PARTS BEFORE STARTING BUILDING PROCEDURE OF YOUR J-3.

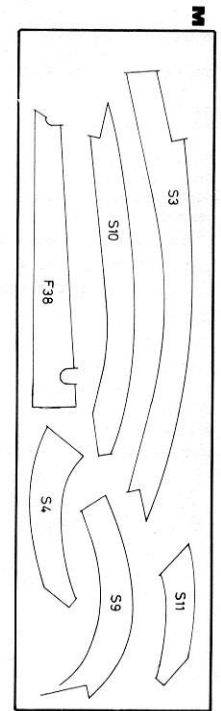
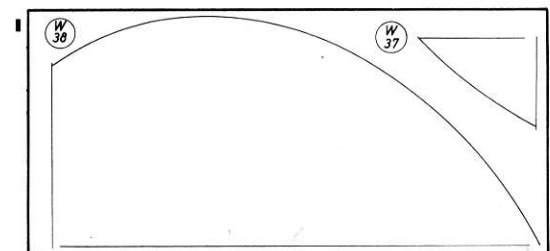
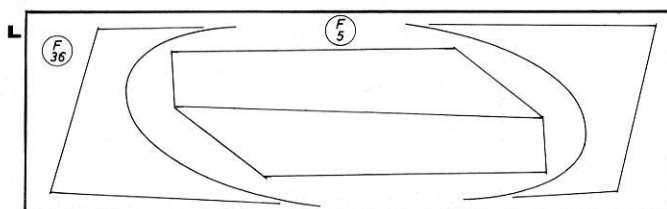
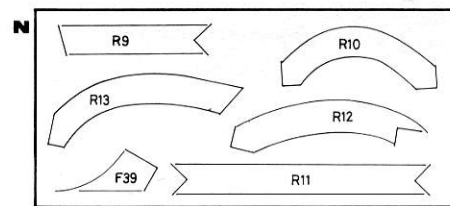
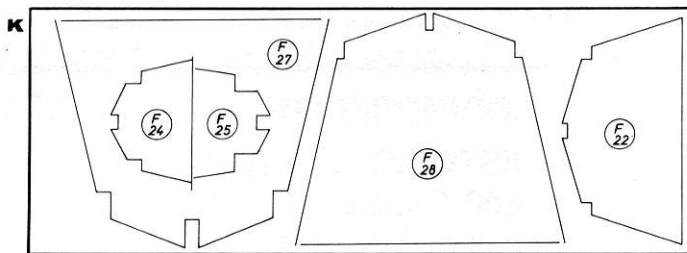
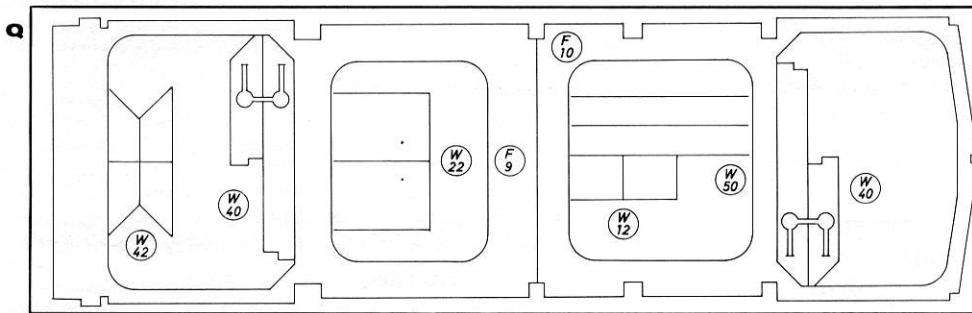
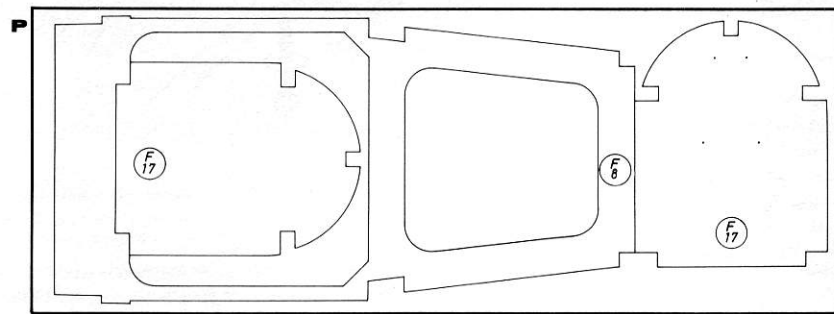
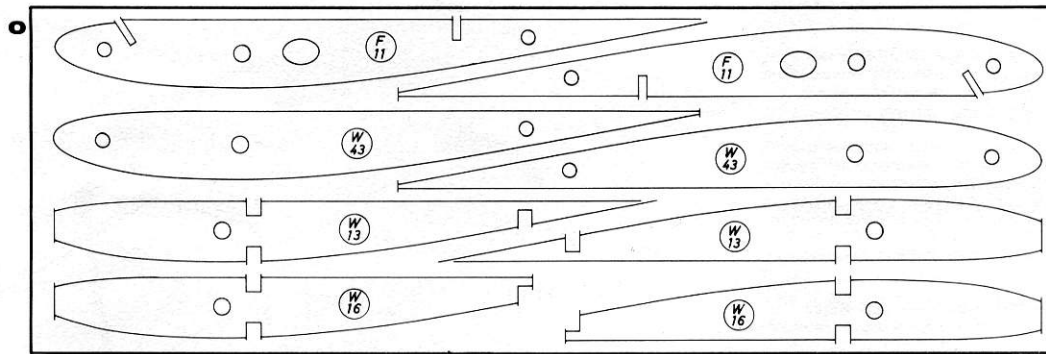

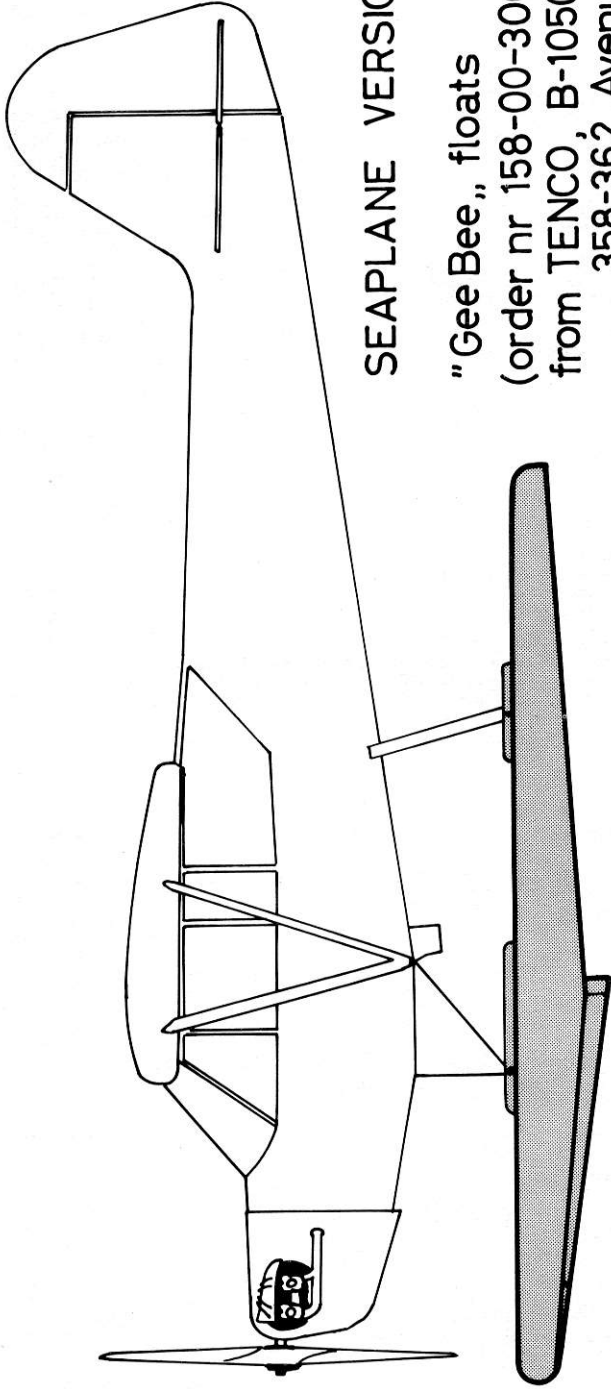

SEAPLANE VERSION

"Gee Bee", floats
(order nr 158-00-30071
from TENCO, B-1050 BRUXELLES
358-362, Avenue de la Couronne)

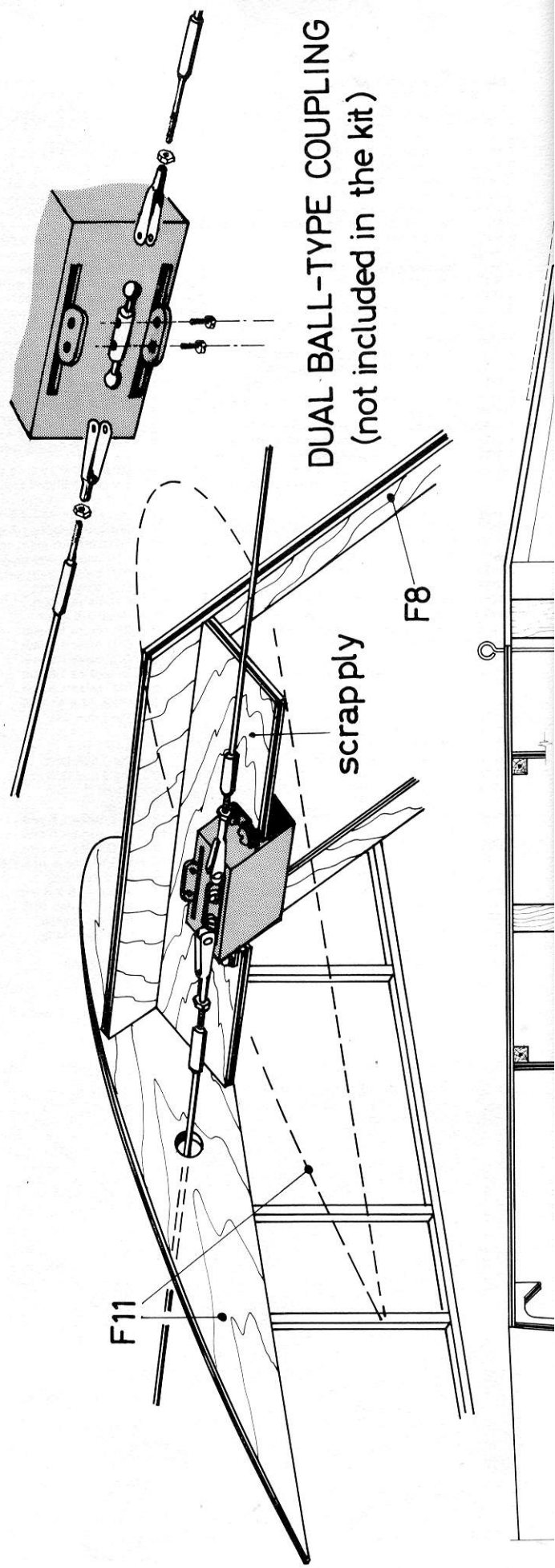

DUAL BALL-TYPE COUPLING
(not included in the kit)

scrapply

F11

F8

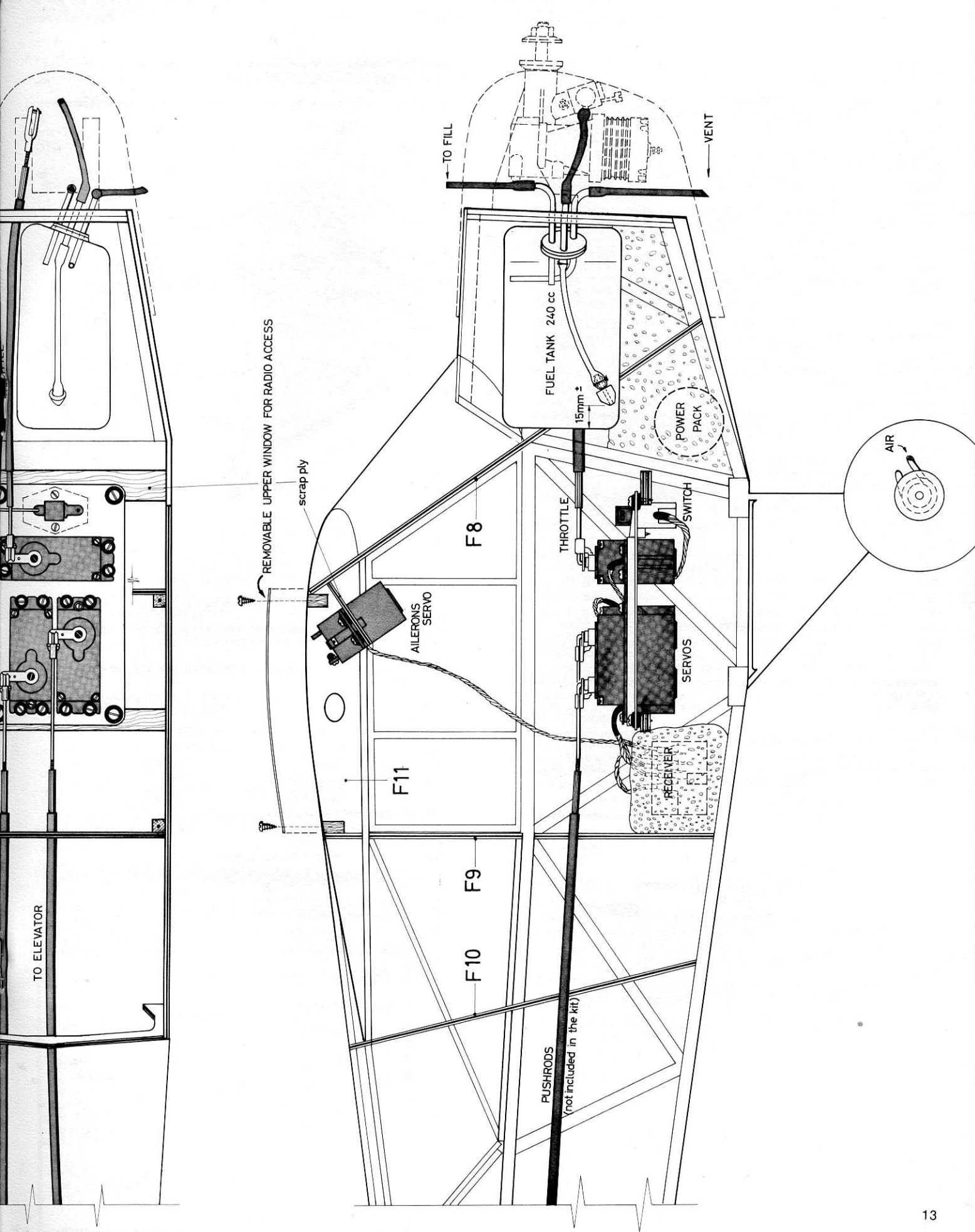

PIPER L-4B «GRASSHOPPER»

The first lightplane ever to have been built literally by the thousands, the PIPER CUB is undoubtedly one of the most pleasant aircraft one can turn into a flying scale-model. The life-size CUB being an ideal scale-subject, what you obtain with the SVENSON-kit is a model built from conventional materials with a very strong frame and an extremely low weight. The very low wing-loading of the model guarantees remarkable flying characteristics.

SVENSON chose to present the military 'Grasshopper'-version of the Piper-aircraft : quite typical of that version is the famous 'green house' which offered the pilot all-around visibility. However, for those who may wish to build the civilian, better-known 'CUB'-version, we have also mentioned the necessary modification on the drawings and we have included the necessary material in the kit.

This model should be powered by an engine from .15 to a maximum of .40 cu.in. The power necessary to fly the model being very low, we would recommend any good engine in the .19/.25 capacity-range, which will give the model a realistic 'scale'-speed, with enough reserve yet for those less than calm flying days. Although this model can certainly fly with rudder, elevator and throttle, a four-channel R/C set will allow the aileron-function.

The 'SVENSON' Piper Cub therefore, is an ideal model for the tyro and the pro alike : the beginner can safely attempt his first flights with a model that looks like a real airplane, and the pro can incorporate a wealth of details into a very realistic scale-model.

Before starting with the actual building of this model however, we would strongly advise that you carefully read the assembly instructions that follow. Construction occurs through the various numbers indicated on the drawings, i.e. start fuselage construction with piece F1 and end up fuselage construction with piece F44.

We at SVENSON wish you lots of fun during the building of your PIPER and uncounted happy landings thereafter

Building the wing

Wings are being built flat, directly onto the plans. Do protect your plans with a plastic sheet (an ideal material to use is the back-up sheet from any iron-on covering, i.e. FLITE-KOTE, SOLARFILM, etc.) in order to prevent the glue from sticking to your plans. For general construction, we would advise using an aliphatic-resin type of glue (such as TITEBOND, which we have found to be ideal for model-use) rather than the faster-setting cellulosic types of cement.

Pin down onto the plan the W1 lower leading edge planking. Also pin down onto the plan the lower trailing edge plankings W2 and W3, gusset W4, planking W5, cap-strips W6, planking W7, cap-strips W8 and gusset W9.

Glue and pin lower main spar W10 into place on planking W5, W6, W7 and on every cap-strip W8.

Glue into place all four ribs W11 - check that each rib is exactly perpendicular to the plan.

Glue into place the wing-hook reinforcement piece W12 against the root rib W11.

Glue into place the 3mm-ply strut-rib W13.

Glue into place ribs W14 to W15 - allow time to dry completely.

Glue into place the 3 mm-ply main strut rib W16.

Slightly curl the W1 planking upwards so that it can come in contact with the lower front part of every rib. Block that planking into place with the appropriate length of balsa strip and then glue that planking to each and every wing rib.

Glue into place the reshaped W17 leading edge to the W1 planking as well as to the front tip of every wing rib.

Glue into place the 6 mm sq. front top balsa strip W18.

Glue into place the 6 mm sq. rear top balsa strip W19.

Glue into place the vertical trailing edge webbing W20 (balsa 10 X 1,5 mm).

Prepare the hardwood 8 mm sq. W21 strut-anchoring blocks by drilling a 3 mm. dia hole through the block and inserting in that hole the appropriate length of plastic tubing (check details with sketch A on plan).

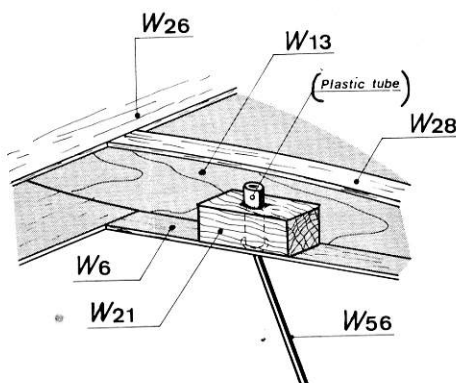

Epoxy-gluе both blocks W21 against W13 rib and W6 cap strip.

Assemble the 90° nylon aileron-bellcrank on its W22-platform, using the screw, washer and nut supplied.

Cut a 55 cm-length of 1,5 mm dia piano-wire and bend its end as illustrated hereunder.

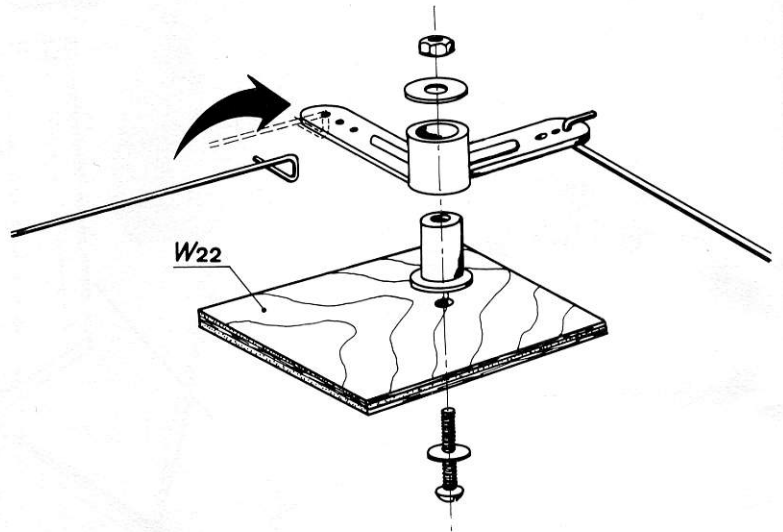

Insert the bent end of your wire into the outer hole of the nylon bellcrank, as shown above.

Install the whole push-rod assembly by sliding the right end of the wire through the hole in rib W14 and guide that wire through every rib until it comes out at the wing root.

Carefully glue platform W22 with its nylon bellcrank to spar W10 and to planking W7 (see sketch B).

PLEASE NOTE : to ensure that there be no binding in the aileron push-rod, you may slide short + 10 mm lengths of 2 mm i.d. plastic tubing onto the rod, and glue the tubings to every second rib.

Glue W23 top trailing edge into place.

Glue the top aileron-hinge-planking W24 into place.

Glue gusset W25 into place.

Glue front top leading edge W26 into place.

Glue center section planking W27 into place (watch wood grain !).

Glue into place the 6 X 1,5 mm balsa cap-strips W28.

Glue into place the wing-tip triangles W29-30-31-32 and the 6 X 3 mm W33 strip into place - Allow time to dry completely.

Glue the wing-tip planking pieces W34-35-36-37.

After the whole wing panel has dried thoroughly, take it off from the building board and glue the bottom wing-tip-planking W38 into place.

Glue into place the front wing-tip block W39.

Epoxy-gluе the strut-supporting half ribs W40 and W40-bis into place.

Give the entire wing panel a careful sanding.

DOCUMENTATION

HISTORIC AVIATION

3850-C Coronation Rd.

Eagan, MN 55122 U.S.A.

Mr. Piper & His Cubs

7.95 \$

The Piper Cub Story

3.95 \$

J3 Cub Service Manual

5.00 \$

Add \$1.00 handling fee
for orders under \$15.00.

Install both W41 strut-anchors, epoxy-glye them both in the slots of the W40 and W40-bis half-ribs, and secure them with both W42 plates. (See detail in sketch C).

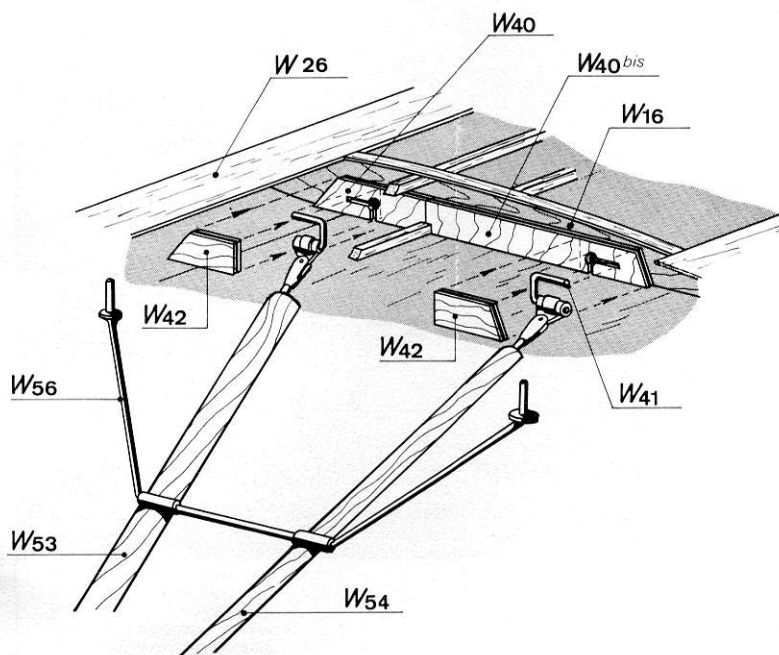

Glue the 3 mm ply root rib W43 into place.

Glue the alignment 6 mm dia dowel-stubs W44 into place.

Screw in the W45 attaching wing hook.

Repeat above procedure for the other wing panel.

Building the ailerons

Pin down onto the plan the lower planking W46.

Glue into place the aileron-ribs W47 as well as the tip rib W48.

Glue into place the slanted W49 planking.

Drill two 3 mm holes in the 3 mm-ply control-horn platform W50, in order to mount the nylon control-horn.

Glue the W50 platform into place and drill the two holes through the bottom planking W46.

Glue 8 mm sq. balsa hinge supports W51 against the slanted W49 planking.

Glue top planking W52 into place.

Sand the entire aileron.

Epoxy glue the nylon control horn into place.

Make the necessary hinge slots in the aileron as well as in the wing leading edge where the hinges are to come. The best tool to use is the GOLDBERG hinge-slotting kit.

Temporarily connect the aileron to the wing with the hinges in place.

Install the aileron push-rod as per plan.

PLEASE TAKE NOTE : the hinges will be definitely glued in and secured with tooth-picks during the finishing of the model.

Building the wing-struts

The right-wing struts are shown full-size on the plans. A precise adjustment of the strut-length is made possible by the threaded ends at each end of the strut.

Prepare the two halves of W53 and W54 from the shaped hardwood supplied.

Provide the necessary recesses for the W55 threaded rods.

Insert the W55 threaded rods in their recesses and then epoxy glue the two halves of W53 and W54 together.

Bevel cut W53 and W54 according to the drawing, assemble both W53 and W54 together flat on the plan, and, when dry, wrap the necessary length of sewing thread around the beveled ends of W53 and W54, smearing the thread with epoxy.

Epoxy glue the mid-strut (W56) anchoring tubes.

PLEASE TAKE NOTE : make sure you build a right wing and a left-wing strut : the anchor tubes for the mid-strut will be on the opposite side when building the left-wing strut !

Building the fuselage

Pin down on the plan the 6 mm sq. balsa strips F1 and F2, glue the vertical tail post F3 (balsa 6 X 12 mm) as well as all the 6 mm sq. balsa braces F4 to both F1 and F2.

PLEASE NOTE : the front part of each fuselage side (see F16 - full size view) must be built separately from the main fuselage sides, directly on the full-size sketch.

Glue into place the F5 planking, through which the rudder and elevator push-rods will have to leave the fuselage.

Glue into place the 3 mm. sq. hardwood spars F6 and F7.

Repeat the above procedure for the left-hand fuselage side, make sure you turn it around before gluing F5-F6 and F7, so as to ensure you have built yourself one left AND one right fuselage side !!!

Join both fuselage sides with cabin formers F8, F9 and F10 (3 mm plywood formers). Check for a **perfect** alignment of this assembly !!

Glue into place the F11 cabin wing ribs - **again**, check for alignment !!!

Glue into place the cabin spars F12 (3 mm sq. hardwood spars).

Assemble the fuselage rear end, using the balsa 6 mm sq. F13 spacers : bevel both F3 vertical tail posts before gluing, the rear ends of the fuselage sides. Again, carefully check for the alignment (as per top view of the fuselage plan) of both the fuselage sides and the F13 spacers.

Glue the hardwood landing gear blocks F14 into place.

Shape and glue into place the 3 mm-balsa bottom F15, making sure the grain is perpendicular to the fuselage center-line.

Carefully mate both F16-assemblies and the F17 firewall : when you are satisfied with the alignment, glue the whole assembly together.

Assemble the F18 instrument panel, the half former F19 and the cowling spar F20 together, then glue this assembly together.

Again, check alignment !!!

Temporarily screw the nylon engine mount into place, epoxy glue the engine mount anchoring nuts to the rear of the firewall.

Now cement the F21 1,5 mm balsa top sheeting to the cowl assembly.

Now cement the F21bis 8 mm balsa bottom sheeting to the F16 assembly.

Glue into place the F22, F23, F24 and F25 fuselage half-formers.

Glue into place the 6 mm sq. balsa 'spine'-spar F26 into place.

Glue together the F27 and F28 half formers and then glue this sub-assembly into place.

Glue the 6 mm. sq. balsa side-spars F29 into place.

Shape and glue into place the 3 mm balsa-sheet cabin rear floor : make sure the wood grain runs perpendicular to the fuselage center-line !

Glue into place the 3 mm sq. hardwood cabin spars F31 and F32.

Sheet the cabin sides with 3 mm balsa-sheet (F33), tailoring to suit.

Where indicated on the drawings, cut out the cabin-side sheetings and insert the 3 mm ply inserts (made from 3 mm plywood scrap) in which the cowl screws will have to be screwed.

Assemble directly on the plan the F35 window spars.

Glue the window spars together.

PLEASE NOTE : if you wish to provide for the operating door and window (in the right fuselage side ONLY !) make small cloth-hinges which will be necessary later on to hinge both door and window. The outline of the operating door and window is shown on the fuselage plan view.

If you have chosen the **civilian J-3 'CUB'-version**, DO NOT FORGET to add an F36 part between formers F9 and F10 on both sides of the fuselage !

Shape and glue into place the F37 front wing fairings : do not forget to provide for a hole in these fairings : in that hole will come the W44 alignment dowel-stubs, once the fairing blocks have been glued against the cabin wing-ribs F11.

Glue into place the stabilizer-saddles F38.

Shape and sand the stab-fairings F40 : do NOT glue them permanently at this stage !!

Glue into place the 3 mm-dowel cabin straightening braces F41 and F42.

Carefully sand the entire fuselage.

Building the stabilizer

Both halves of the stabilizer are built simultaneously, flat on the plan .

Pin down the main spars S1 and the leading edges S3 and S4 directly on the plan.

Glue the 6 X 3 mm balsa ribs S2, S3, S4 and S5.

Glue the 6 mm dia. reinforcing dowels S6 and S7 into place.

Glue the 6 mm scrap-balsa gussets into place.

Pin down the elevator leading edges S8 as well as the trailing edges S9, S10 and S11 on the plan.

Glue the ribs S5 and 6 mm scrap-balsa triangular gussets.

Glue the joining 6 mm dowel S12 into place.

Temporarily install the four stabilizer hinges.

Building the fin

Pin the 6 X 12 mm balsa R1 post on the plan.

Pin, and glue together the 6 X 12 mm balsa R2 piece and the 6 mm. sq. R3 piece.

Pin and glue the fin-top R4 (balsa 6 mm sq.).

Pin the 6 X 12 mm balsa leading edge R5.

Glue the various 6 X 3 mm balsa spars R6 into place.

Building the rudder

Pin the 6 mm sq. balsa vertical rudder post R7 on the plan.
 Glue the balsa 6 X 12 mm control-horn reinforcement R8 into place.
 Pin and glue together the various pieces of the rudder trailing edge R9, R10, R11, R12 and R13.
 Glue ribs R6 (balsa 6 X 3 mm) and R14 (balsa 6 X 12 mm).
 Temporarily install rudder hinges.
 Shape and sand rudder to plan contour.

Assembling the empennage (Tail unit) :

this assembly can only occur once the stabilizer, fin and rudder have been covered. We do very strongly advise using the fantastic SUPER-COVERITE material : it has a true fabric structure and will give you a realistic finish, once painted with a 'flat'-type of paint (See 'finishing the model').
 Position the stabilizer on the fuselage, the parts S6 and S7 of the stabilizer resting on the F38 saddles. Check that the stabilizer is horizontal, and does not 'tilt' one way or the other !!!
 Position the fin. The vertical R1 post should be glued against the F3 fuselage posts. Check that the rudder is absolutely perpendicular to the stabilizer !
 Drill a 1,5 mm dia hole in the vertical post R1 and in the stabilizer main spars S1 where indicated on the plan.
 Epoxy glue the 1,5 mm dia. wire stab-struts in the holes you have previously drilled.
 Install the steerable tail wheel assembly into place.

Building the main landing gear

Bind and solder together the various elements of the landing gear. Using the F14 landing blocks in the fuselage, you will be able to determine the distance between the front and the rear legs of the landing gear.
 Fill the space between the front and rear legs with 3 mm sheet balsa (F43) using epoxy glue.
 Shape the rubber dampers F44 from 15 X 15 X 40 mm balsa scrap-blocks.
 Install the landing gear in the fuselage using small drilled metal plates and wood screws.



SVENSON MODELS BELG.		
Metal parts for Piper CUB J3		
part	quantity	diameter
A	1	3 mm
B	1	3 mm
C	1	2 mm
D	4	2 mm
E	2	2 mm
F	1	15 mm
G	1	15 mm
H	2	15 mm

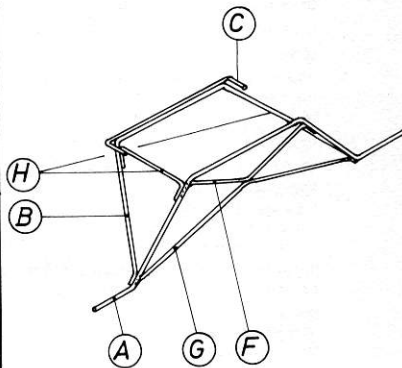

Assembling the moulded cowl

Glue both halves of the engine cowl together using 'plastic kit'-type glue.
 Reinforce the seam with a narrow strip of fiberglass cloth.
 Drill out the necessary holes for engine-cooling, needle valve, and exhaust gases. Do not forget to provide for an easy access to the engine glow-plug.
 Attach the cowl to the fuselage with wood screws driven in the F34 plates.

Assembling the cabin

Glue the windshield into place.
 Cut out the side windows as well as the top window and glue all parts into place.



PACKING LIST

W 1	Bottom leading-edge planking	2	Balsa 750 X 43 X 1.5 mm	F31	Cabin spar	1	Hardwood 3 mm sq.
W 2	Bottom trailing-edge planking	2	Balsa 310 X 43 X 1.5 mm	F32	Cabin side-spar	2	Hardwood 3 mm sq.
W 3	Bottom aileron-hinge planking	2	Balsa 445 X 20 X 1.5 mm	F33	Cabin-side planking	1	Balsa sheet 3 mm
W 4	Gusset between W3 and W2	2	Die-cut balsa 1.5 mm	F34	Cowl mounting plate	4	Plywood-scrap 3 mm
W 5	Bottom wing-root planking	2	Balsa sheet 1.5 mm	F35	Window spar	1	Hardwood 3 mm sq.
W 6	Cap-strip for the mid-strut rib	2	Balsa 11 X 1.5 mm	F36	Window-frame for J-3 version	2	Die-cut balsa 3 mm
W 7	Bottom aileron-bellcrank planking	2	Balsa sheet 1.5 mm	F37	Front wing-fairing block	2	Balsa 45 X 45 X 30 mm
W 8	Bottom cap-strip	12	Balsa 6 X 1.5 mm	F38	Stabilizer saddle	2	Die-cut balsa 6 mm
W 9	Bottom wing-tip gusset	2	Die-cut balsa 1.5 mm	F39	Gusset between rudder and fuselage	1	Die-cut balsa 6 mm
W10	Bottom main spar	2	Balsa 6 mm sq.	F40	Fairing block between rudder-fuselage and stabilizer	2	Balsa 130 X 20 X 20 mm
W11	Wing rib	8	Die-cut balsa 1.5 mm	F41	Cabin straightening brace	2	3 mm dia. hardwood dowel
W12	Wing-hook reinforcement plate	2	Die-cut plywood 3 mm	F42	Cabin straightening brace	3	3 mm dia. hardwood dowel
W13	Mid-strut rib	2	Die-cut plywood 3 mm	F43	Landing gear leg fairing	2	Balsa sheet 3 mm
W14	Wing-rib	8	Die-cut balsa 1.5 mm	F44	Rubber damper	2	Balsa 15 X 15 X 40 mm
W15	Wing-tip ribs	4	Die-cut balsa 1.5 mm				
W16	Main strut-wing-rib	2	Die-cut plywood 3 mm	S 1	Main stabilizer spar	2	Balsa 6 X 12 mm
W17	Leading edge	2	Shaped balsa	S 2	Root rib (stabilizer)	2	Balsa 6 X 12 mm
W18	Top main spar	2	Balsa 6 mm sq.	S 3	Leading edge	2	Die-cut balsa 6 mm
W19	Rear spar	2	Balsa 6 mm sq.	S 4	Leading edge	2	Die-cut balsa 6 mm
W20	Vertical aileron webbing	2	Balsa 10 X 1.5 mm	S 5	Stabilizer ribs	12	Balsa 6 X 3 mm
W21	Mid-strut anchoring block	4	Hardwood 8 mm sq.	S 6	Leading-edge reinforcement	1	Hardwood dowel 110 mm/6 mm
W22	Aileron-horn plate	2	Die-cut plywood 3 mm	S 7	Trailing-edge reinforcement	1	Hardwood dowel 150 mm/6 mm
W23	Top trailing-edge planking	2	Balsa 310 X 43 X 1.5 mm	S 8	Elevator leading edge	2	Balsa 6 X 12 mm
W24	Top aileron hinge planking	2	Balsa 510 X 20 X 1.5 mm	S 9	Elevator trailing-edge	2	Die-cut balsa 6 mm
W25	Gusset between W24 and W23	2	Die-cut balsa 1.5 mm	S10	Elevator trailing-edge	2	Die-cut balsa 6 mm
W26	Top leading-edge planking	2	Balsa 750 X 43 X 1.5 mm	S11	Elevator trailing-edge	2	Die-cut balsa 6 mm
W27	Top wing-root planking	2	Balsa sheet 1.5 mm	S12	Elevator joining piece	1	Hardwood dowel 150 mm/6 mm
W28	Top cap-strip	16	Balsa 6 X 1.5 mm	S13	Fin and stabilizer-strut	1	1.5 mm dia. piano-wire
W29	Wing-tip triangle	2	Die-cut balsa 3 mm				
W30	Wing-tip triangle	2	Die-cut balsa 3 mm	R 1	Fin vertical post	1	Balsa 6 X 12 mm
W31	Wing-tip triangle	2	Die-cut balsa 3 mm	R 2	Fin base	1	Balsa 6 X 12 mm
W32	Wing-tip triangle	2	Die-cut balsa 3 mm	R 3	Fin base	1	Balsa 6 mm sq.
W33	Wing-tip triangle	2	Die-cut balsa 3 mm	R 4	Fin top	1	Balsa 6 mm sq.
W34	Wing-tip top-planking	2	Die-cut balsa 1.5 mm	R 5	Fin leading edge	1	Balsa 6 X 12 mm
W35	Wing-tip top-planking	2	Die-cut balsa 1.5 mm	R 6	Fin spar	1	Balsa 6 X 3 mm
W36	Wing-tip top-planking	2	Die-cut balsa 1.5 mm	R 7	Rudder vertical post	1	Balsa 6 mm sq.
W37	Wing-tip top-planking	2	Die-cut balsa 1.5 mm	R 8	Control-horn mounting plate	1	Balsa 6 X 12 mm
W38	Wing-tip bottom planking	2	Die-cut balsa 1.5 mm	R 9	Rudder trailing-edge	1	Die-cut balsa 6 mm
W39	Wing-tip block	2	Balsa 70 X 40 X 30 mm	R10	Rudder trailing-edge	1	Die-cut balsa 6 mm
W40	Strut-supporting half rib	2	Die-cut plywood 3 mm	R11	Rudder trailing-edge	1	Die-cut balsa 6 mm
W40bis	Strut-supporting half rib	2	Die-cut plywood 3 mm	R12	Rudder trailing-edge	1	Die-cut balsa 6 mm
W41	Strut-anchors	4	2 mm dia piano-wire	R13	Rudder trailing-edge	1	Die-cut balsa 6 mm
W42	Strut-anchor-plates	4	Die-cut plywood 3 mm	R14	Rudder rib	1	Balsa 6 X 12 mm
W43	Root wing-rib	2	Die-cut plywood 3 mm				
W44	Alignment dowel stub	4	Hardwood dowel 6 mm dia.				
W45	Attaching wing-hook	2	Steel				
W46	Bottom aileron planking	2	Die-cut balsa 1.5 mm				
W47	Aileron rib	12	Die-cut balsa 1.5 mm				
W48	Aileron tip-rib	2	Die-cut balsa 1.5 mm				
W49	Slanted aileron planking	2	Balsa 440 X 10 X 1.5 mm				
W50	Control-horn mounting plate	2	Die-cut plywood 3 mm				
W51	Hinge-support	6	Triangular balsa 8 X 8 mm				
W52	Aileron top-planking	2	Die-cut balsa 1.5 mm				
W53	Main strut	4	Shaped hardwood				
W54	Rear strut	4	Shaped hardwood				
W55	Threaded rod 2 mm	4	Steel				
W56	Mid-strut	2	2 mm dia. piano wire				
F 1	Fuselage-side bottom spar	2	Balsa 6 mm sq.				
F 2	Fuselage-side top spar	2	Balsa 6 mm sq.				
F 3	Vertical post	2	Balsa 6 X 12 mm				
F 4	Fuselage-side brace	1	Balsa 6 mm sq.				
F 5	Push-rod exit planking	2	Die-cut balsa 3 mm				
F 6	Center fuselage side spar	2	Hardwood 3 mm sq.				
F 7	Top fuselage side spar	2	Hardwood 3 mm sq.				
F 8	Front cabin former	1	Die-cut plywood 3 mm				
F 9	Center cabin former	1	Die-cut plywood 3 mm				
F10	Rear cabin former	1	Die-cut plywood 3 mm				
F11	Cabin wing rib	2	Die-cut plywood 3 mm				
F12	Cabin spar	2	Hardwood 3 mm sq.				
F13	Fuselage spacer	1	Balsa 6 mm sq.				
F14	Landing gear block	2	Hardwood 20 X 10 mm				
F15	Fuselage bottom	1	Balsa sheet 3 mm				
F16	Front fuselage side sub-assembly (F1-2-4)	1	Balsa 6 mm sq.				
F17	Firewall former	2	Die-cut plywood 3 mm				
F18	Instrument panel	1	Die-cut balsa 3 mm				
F19	Cowl half-former	1	Die-cut balsa 3 mm				
F20	Cowl top-spar	1	Balsa 6 mm sq.				
F21	Cowl planking	1	Balsa sheet 1.5 mm				
F21bis	Cowl bottom	1	Balsa sheet 8 mm				
F22	Fuselage top half-former	1	Die-cut balsa 3 mm				
F23	Fuselage top half-former	1	Die-cut balsa 3 mm				
F24	Fuselage top half-former	1	Die-cut balsa 3 mm				
F25	Fuselage top half-former	1	Die-cut balsa 3 mm				
F26	Fuselage spine spar	1	Balsa 6 mm sq.				
F27	Slanted cabin half-former	1	Die-cut balsa 3 mm				
F28	Slanted cabin half-former	1	Die-cut balsa 3 mm				
F29	Fuselage side-spar	2	Balsa 6 mm sq.				
F30	Cabin rear-floor	1	Balsa sheet 3 mm				

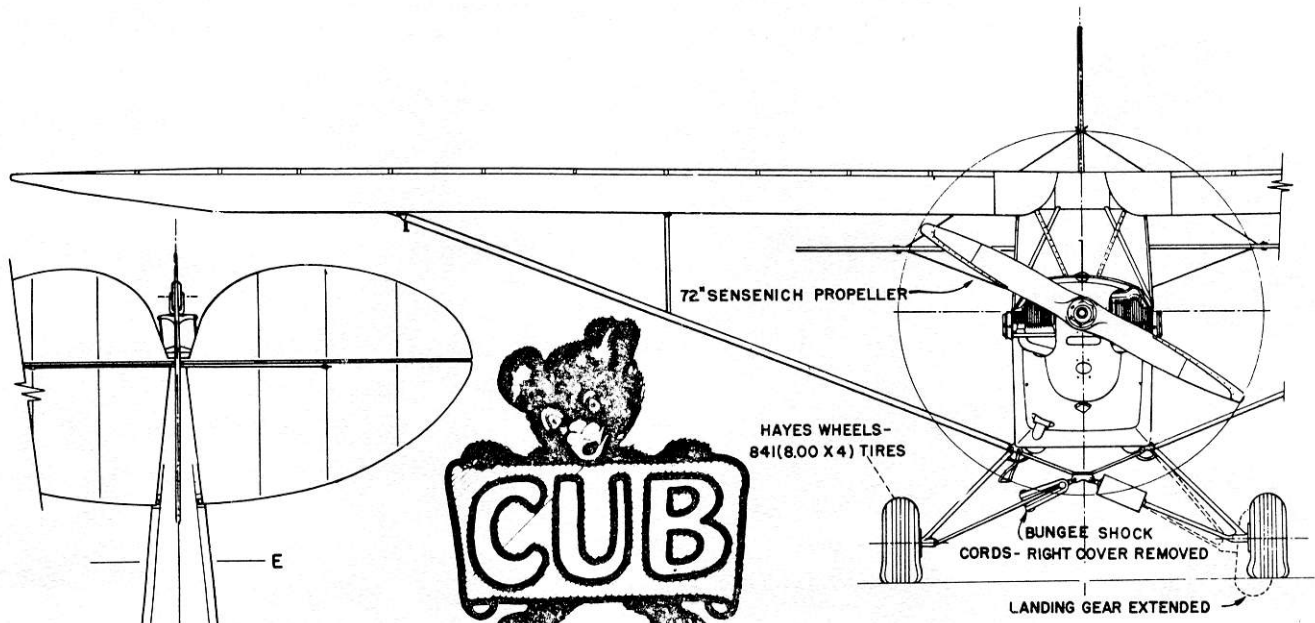

Specifications: Length 22' 4½"; Height 6' 8"; Span 35' 2½"; Empty weight 680 lbs; Useful load 540 lbs, Gross weight 1220 lbs; Wing loading 6.83 lbs/sq ft; Power loading 18.8 lbs/hp. Powerplant: J3C-65, Continental A65-8; J3F-65, Franklin 4AC-176; J3L-65, Lycoming O-145 (this is the engine shown on the plans)—All four cylinder, horizontally opposed, air cooled engines, rated 65 hp at sea level; Fuel capacity, 12 U. S. gallons; Oil capacity, 4 quarts; Fuel consumption, 4.08 gallons per hour. Performance: Top speed 87 mph; Cruising speed 75 mph; Landing speed (stalling) 38 mph; Rate of climb at sea level 450 feet/minute; Service ceiling 11,500 feet; Normal range 220 miles; Gliding ratio 10 to 1.

