

CAN YOU NAME

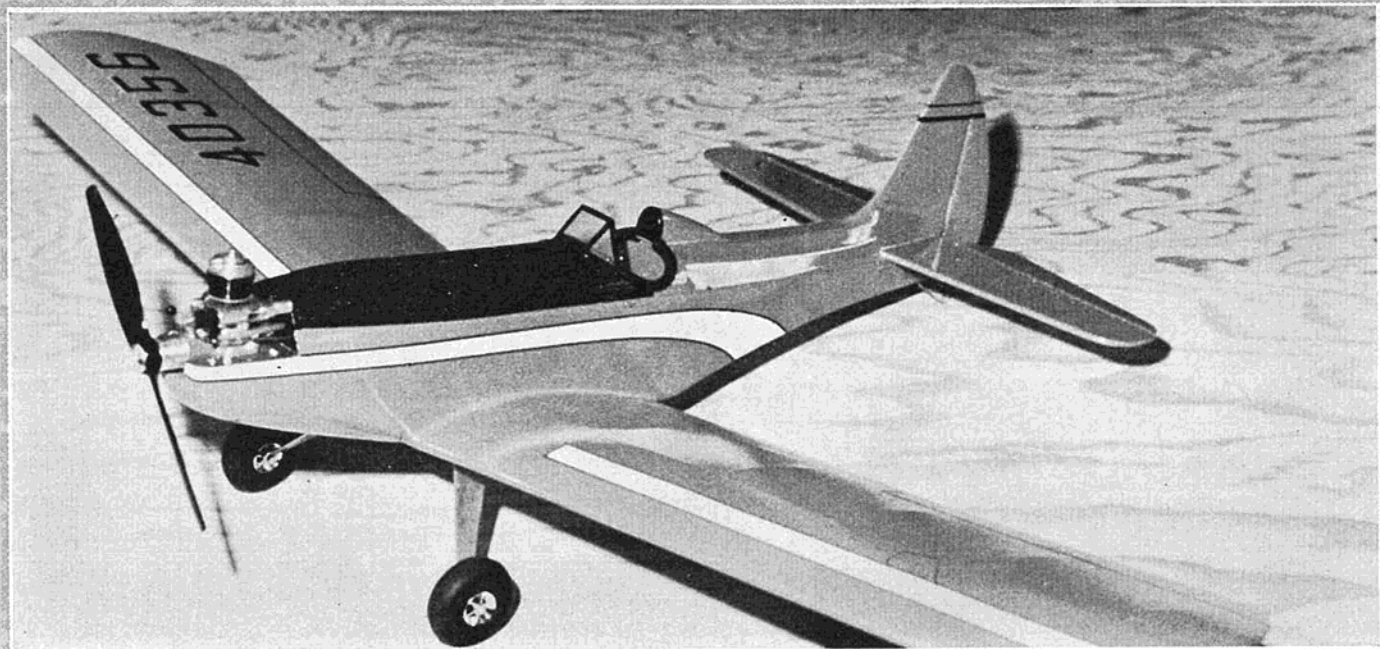

. . . RCM'S 'PLANE ON THE COVER'?



A sensation wherever it's been shown or flown, Herb Abrams' .09 powered low-winger for proportional control lacks only a name. If yours is selected by RCM, you'll win a new proportional system, actuator, and a two-year subscription. Interested? Read on

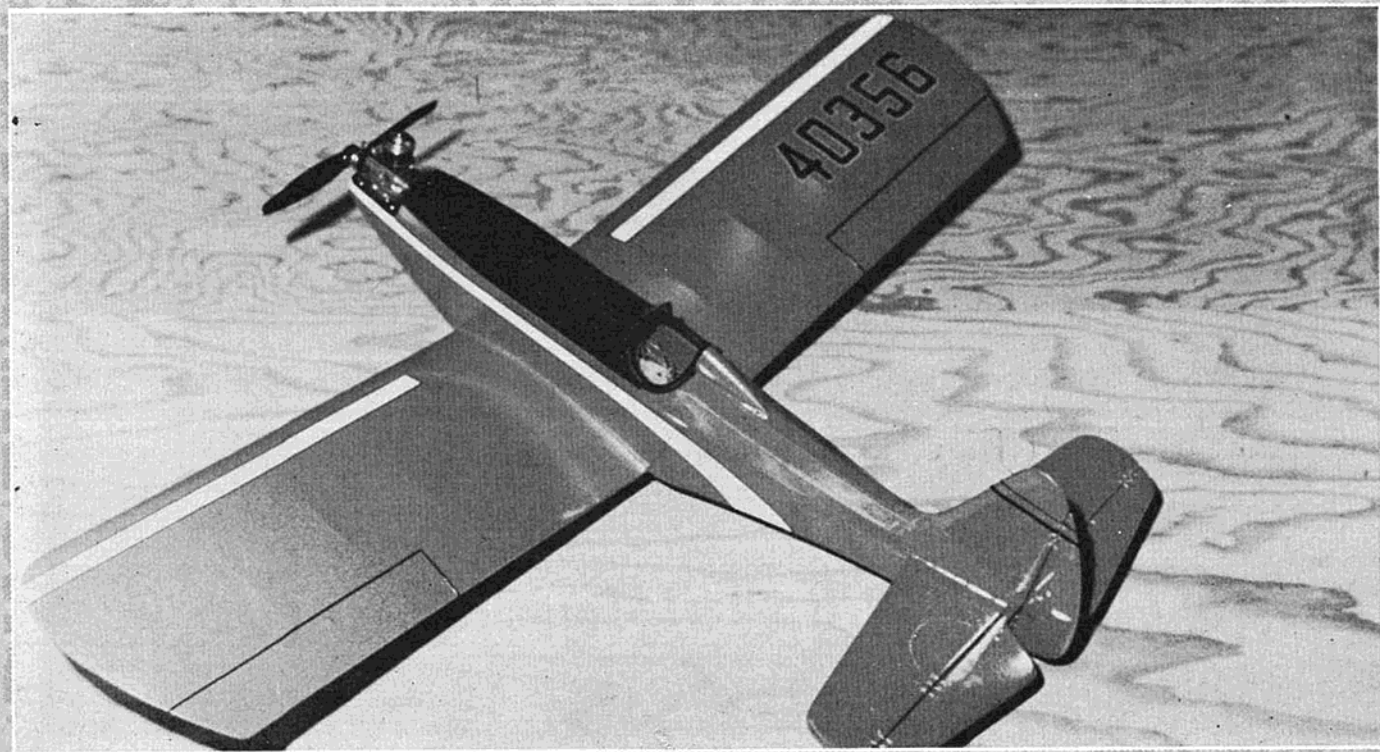

DATA SHEET

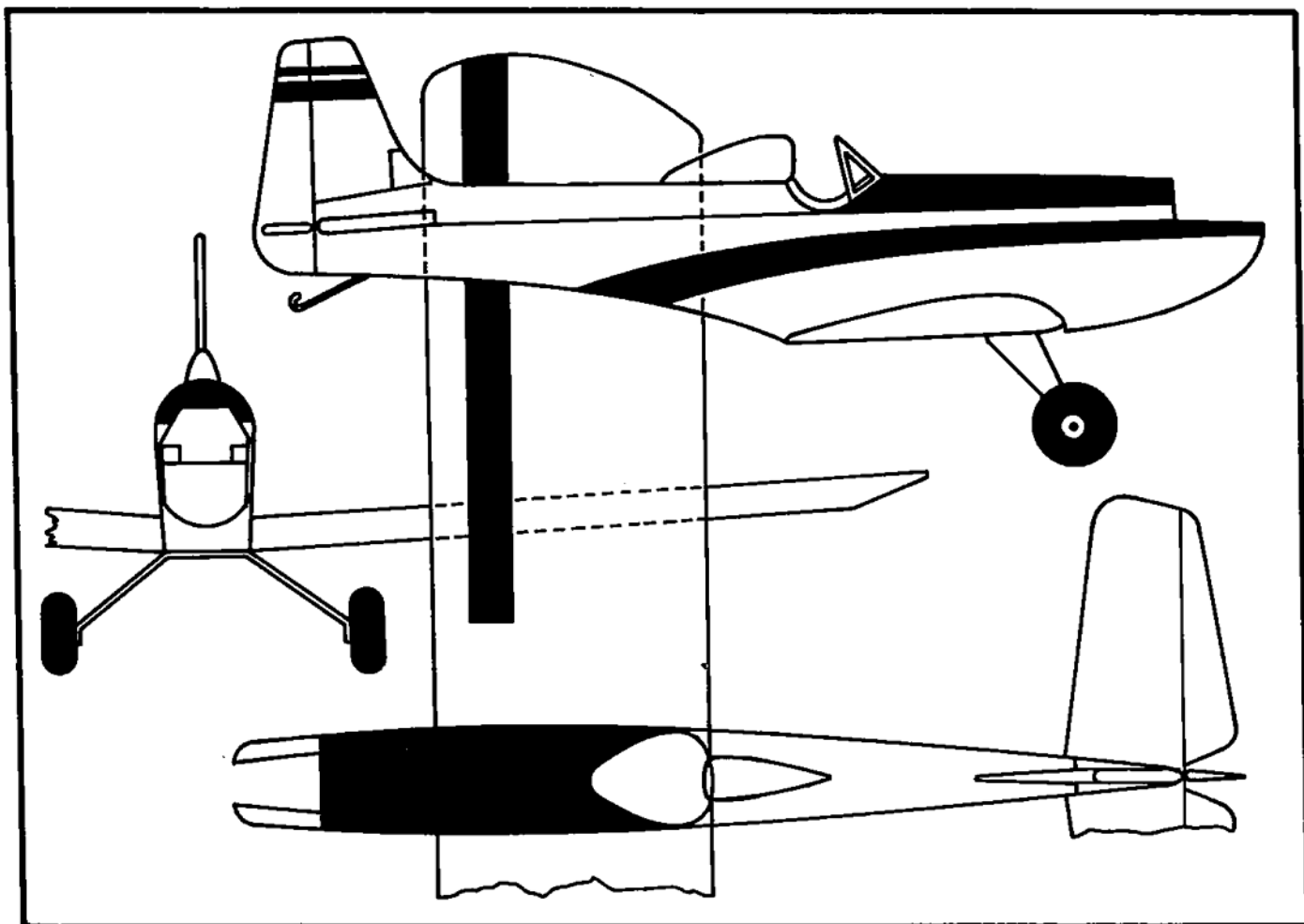

ENGINE

.049 to .10. Cox .09 Medallion with throttle recommended.

DIMENSIONS

Wingspan: 36" Chord: 7"
Total Wing Area: 252 square inches
Fuselage Length: 25" Max. Fuselage Width: 2½"
Engine Thrust Offset: 3 degrees down
3 degrees right

FLIGHT CHARACTERISTICS

Sport design for single channel proportional control of rudder, elevator, and throttle. Very short ROG's, fast, stable, and responsive. Limit elevator movement to minimum on first flights.

RC EQUIPMENT

Prototypes used Min-X 1200S superhet single channel proportional system with Rand LR-3 Galloping Ghost actuator.

MATERIAL LIST

Wings:

- (1) ½" x ½" x 36"
- (1) ¼" x 1" x 36"
- (1) ¼" x 2" x 36"
- (1) ¼" x 3" x 36"
- (2) ¾" x ¾" x 36"
- (1) ¼" x 1" x 36"
- (1) ¾" x 3" x 36"
- (2) ¼" x ¾" x 36"
- (1) ⅛" x 3" x 36"

Tail Group:

- (1) ⅛" x 3" x 36"

Fuselage:

- (2) ¾" x 3" x 36"
- (1) ¾" x 3" x 36"
- (2) ½" x ½" x 36"
- (1) ⅛" x 3" x 8" (scrap)
- (1) ¾" x 6" x 12" plywood
- (1) 1" x 3" x 6"
- (1) 1" x 3" x 8"
- (1) ¾" x ¼" x 12" motor mount stock

THIS outstanding little low-wing design was originally conceived by Jack Lemon and Ellsworth Miller in 1957, and in its original configuration, was flown with escapements and pulse proportional for rudder only sport and contest work. My first encounter with this spritely looking machine occurred one Sunday morning when I stopped by Jack's house on the way to the flying field. It didn't take much arm-twisting to get Jack to agree to take it out to the field. The ensuing flights were beautiful — the plane was fast enough to provide a challenge, yet slow enough to make me want to try it!

After flying it on rudder-only, I could hardly wait to try it out on Galloping Ghost. The addition of elevator would add a new dimension to its flying and utility. Learning that Ellsworth Miller had built four of these models on almost a production basis, I purchased two of the existing models for my experiments. Even though they were, by now, eight years old, I found them to be in perfect condition.

Elevators were quickly added and a Rand LR-3 actuator installed. Radio equipment consisted of a Min-X Pulsemite 1200 transmitter and receiver combination. Back at the field, once again, we learned our first lessons about this airplane — the first flights were quite short, consisting of take-offs and snap rolls into the ground. The vicious stalls and subsequent snap rolls were caused by our failure to block the wing to the proper incidence angle. Several repeated attempts to fly the model ended in the same manner, yet the model sustained no damage whatsoever. Ellsworth had designed the airplane as strong as possible in order to withstand this type of activity — the design emphasis having been to build it simply, yet strong, the slight additional weight penalty being of less severity than the damage a less well-constructed model would sustain. He had proved to be an able designer!

After determining the proper incidence, plus making a few additional changes, the model performed beyond all expectations. With proportional rudder and elevator plus throttle control on the Cox Medallion .09, the plane is one of the most outstanding sport fliers we have ever encountered. It is a fairly fast model, responsive to command, and capable of some pretty fancy maneuvers! Although the size would dictate an .049 engine, and if built quite lightly this size engine would probably suffice, we used a Cox Medallion .09 with throttle on all prototypes. Don't let the power to size ratio frighten you, since the continually moving surfaces on pulse-proportional control induces drag that must be offset by additional engine power. **You can fly this plane — and you'll enjoy every minute of it!**

You can also win a new Min-X 1200 proportional transmitter and receiver and Rand LR-3 actuator, complete with wiring harness, if you submit the best name for this design. Originally called the Penetrator because of its ability to fly in high winds, we discovered that this was the name for a leading Class I contest design. From this dilemma came the idea of the Name-The-Plane Contest. As an added incentive, RCM is adding a two-year subscription for the winner. Let's get on with construction.

Wing

The wing is simplicity itself, with only a few additional hints needed to help the constructor. The panels are built using the lower sheeting as a base. The trailing edge filler strip should be finished to final shape prior to the installation of the ribs. If the latter are left a little thick at the trailing edge, they can easily be blended to match the filler strip after installation. Do not sheet the top of the wing until the panels have been joined to the center section, and until the spars, gussets, and wing tips have been added.

Sheet the center section to the middle of the $\frac{1}{4}$ " thick center ribs and then add the top sheeting and capstrips. I would suggest that the plywood landing gear plate be epoxied in place and that 1" wide reinforcing strip be applied at the dihedral joints. When the wing is completed, sand lightly, then spray the entire structure with two coats of thin dope before covering.

Fuselage

The actuator mounting plate is used to key the fuselage square. The two side doublers, along with formers F2, F3, and F4, form a box which is held square by the mounting plate F6. If all of these members are glued with HobbyPox, the box can be made at one time and held in place with rubber bands and masking tape. The box should be turned over on a flat surface while drying in order to prevent any possible twisting.

The wing-nest sheeting is applied and finished flush. This is accomplished in order to provide an inner lock joint with the sides. The motor mount assembly can be positioned in this inner structure at this time, gluing firewall F1 in position at the same time. The ends of the motor mounts will have to sprung-in to bear against F2. Again, HobbyPox glue should be used at this point. A soft balsa nose block glued in place and finished flush completes this structure. The sides can now be glued in place and the addition of former F5 and the $\frac{3}{16}$ " square hard balsa used for the vertical stabilizer added to complete the basic fuselage.

The pictorial drawing illustrates the manner in which the fuselage sides are trimmed to match Former F1. Filler

NAME THE PLANE

(Continued from Page 30)

pieces have been added to form the contour. A notch is shown which provides excess stock for trimming. Provision has been made for the motor control push rod housing, the latter being $\frac{3}{8}$ " nylon tubing which is glued in place. Plastic balsa can be used to fill and blend the area above the motor mounts.

A very practical feature of this plane is the use of a full-length hatch which exposes all of the gear for checking and inspection. This hatch is cut from soft balsa with $\frac{1}{16}$ " plywood formers on the ends and at position F2 to hold the hatch pin.

The stringers adjacent to the vertical stabilizer must be trimmed to be fit into position. These stringers are notched on the ends so that the cockpit cover and tail fillet will blend properly. Note the angle of incidence of the wing is $2\frac{1}{2}$ degrees positive and that the angle of the horizontal stabilizer is 2 degrees. The fuselage sides must be trimmed prior to final assembly so that the final incidence angle between wing and stab is $\frac{1}{2}$ degree. The object is to have the model fly in a tail-high position.

A note about using the Cox throttle in this installation — the position of the motor control pushrod will not match the Cox throttle linkage at the rear of the exhaust restrictor, so the linkage is simply moved to the front of the exhaust restrictor, using the same screw that holds the linkage from the carburetor.

Elevators

The elevators are made from $\frac{3}{16}$ " soft sheet balsa with $\frac{3}{16}$ " dowel epoxied in

(Continued on Page 70)

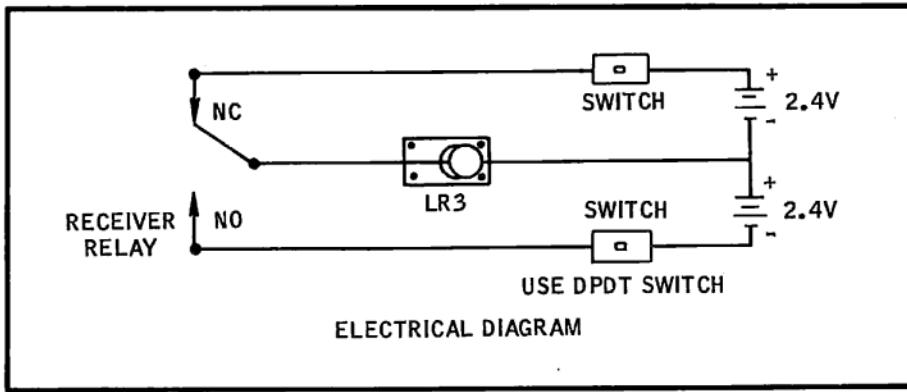

place to join the two halves. A long control horn is used to limit the control motion.

Radio Installation

Before going into the actual radio installation, let's clear up some confusion about Galloping Ghost for the benefit of the newcomer to radio control. Quite simply speaking, GG is "getting the most with the least." That is, proportional control of the rudder and elevator, along with throttle control, from a single channel system and only one actuator. There are three variables transmitted from the Galloping Ghost trans-

mitter — pulse rate, pulse width, and tone-on or tone-off. These are transmitted via the pulse coder and received by the superhet receiver. They are, in turn, mechanically decoded by the actuator. The latter moves the control surfaces to give the desired proportional control. Now, let's apply these commands to the Rand LR-3 actuator and see what happens:

The rate information controls the position of the elevator cam plate in relation to how fast the actuator motor os-

(Continued on Page 73)

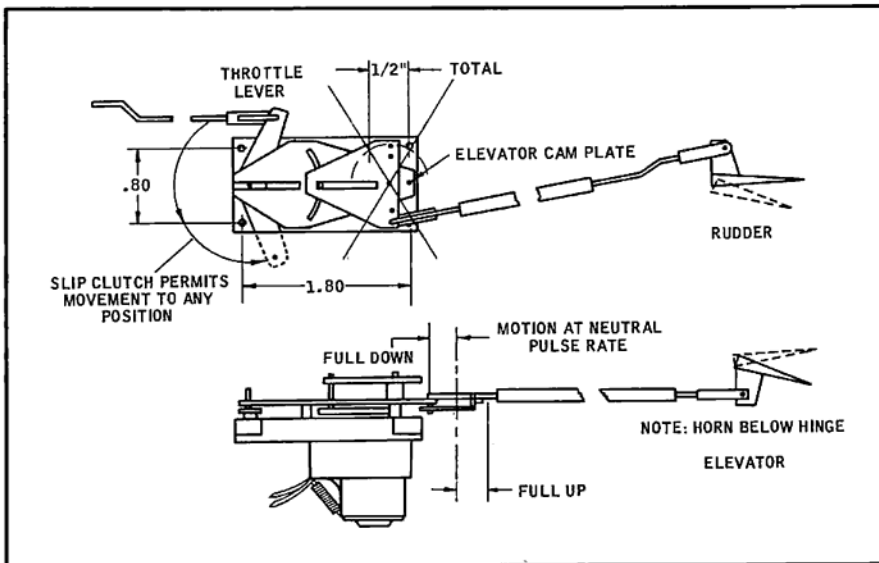

cillates. At high pulse rates, the crank does not have time to move very far. Therefore, the effect is for full down elevator. At low pulse rates the crank has time to move about 270 degrees with the effect of up elevator. At neutral pulse rates the crank swings back and forth approximately 100 degrees ($\frac{5}{16}$ "), which motion causes the elevator to move up and down equally for effective neutral elevator.

The pulse width variable causes the actuator motor to turn more in one direction than the other, which means that the rudder assumes an average position to the right or left.

A steady tone-on or steady tone-off causes the actuator to turn 360 degrees five times for full throttle con-

trol, provided by the adjustable arm on the actuator. Signal-off is used for low motor in order to provide a fail-safe operation in case of any system malfunction. The controls are moved rapidly through their extreme positions during throttle changes giving effective neutral control action at the rudder and elevator.

During all periods of operation, the control surfaces are moving, or cycling, through their positions, giving a neutral position 1 until the transmitter stick is moved, at which time the surfaces move toward the given signal. Due to the high rate of the pulses, the wiggle of the control surfaces is barely perceptible in flight.

The trim lever setting on the transmitter selects the neutral pulse rate, and

therefore, the amount of control surface motion. As in ordinary multi aircraft, the pushrod adjustment is used for flight trim. The transmitter trim levers are used for in-flight trim.

The receiver used in the prototypes is the new Min-X SH-1 superhet receiver, the smallest production relay superhet on the market today, measuring $1\frac{5}{16}$ " x $1\frac{7}{16}$ " x $1\frac{15}{16}$ " and weighing only two ounces. Two alkaline energizers or three 225 ma nicad button cells can be used for the receiver power supply. A separate power supply is used for the actuator, consisting of four 500 ma nicad pencells or 450 ma button cells. Many tests were conducted with several different receivers and various switcher circuits for eliminating the two separate sets of batteries. It was found that, regardless of whose receiver was used, that a 50% loss in range could be expected when using a common battery supply to the actuator and receiver. In addition, we tried operating the actuator on 3.6 volts using the switcher. It turned out to be a disadvantage, since the actuator is set up on 2.4 volts to move proportionally with a 70-30 width change. Many factors effect this relationship, such as the actuator itself, motor, torque and speed characteristics, and the spring rate of the centering spring. On 2.4 volts, measured at the actuator, motor control will be normal. If 2.4 volts is used through a switcher, a voltage drop occurs, so that the actuator will have less than two volts and motor control will not be reliable. The diagram shows the proper method of wiring. Connect the leads to the actuator so that the throttle control moves to low throttle on low motor signal — signal OFF. Simply reverse the leads if it moves in the wrong direction. With the transmitter signaling left turn, note the position of the actuator rudder plate. Connect the rudder pushrod to the appropriate side to give left rudder. Adjust the pushrod length for neutral. Connect the elevator pushrod as illustrated. Observe the motion of the elevator with the stick and trim in the neutral position, which is 6 pulses per second. Adjust the length of the pushrod so that the elevator moves approximately the same amount above and below the center line. Connect the pushrod on the furthest "out" position on the elevator horn for initial flights. Be sure all of your control linkages are free. Watch for binding of your Kwik Links at the control horns, caused by too much tension, or keepers that are too tight, or misalignment of pushrod to control horn.

Flight Trim

Balance the airplane as shown. The airplane will take off in 10 or 15 feet and be quite sensitive to the controls. If there is any tendency to gallop, increase the pulse rate and lengthen the elevator pushrod to compensate. Good flying — and don't forget to send in your selection for a name for this plane!