

The Mirage 550

Wingspan:	54"
Wing Area:	464 sq. "
Length:	39"
Flying Weight:	40-46 oz.
Power:	Turbo 550 electric

INSTRUCTIONS

Watch the Mirage—the beautiful Mirage! It's really there, but listen closely and you may not even hear it! Electric flying at its best—relaxed, quiet and fun! **Mirage's** excellent flying characteristics make her very easy to fly, yet still capable of exciting aerobatics like loops, rolls, stall turns and more. Whether for training or sport flying, you have one of the finest electric airplanes available.

Your successful first flight begins right here. Before starting assembly, please read carefully through this instruction booklet. It won't take that long, and building your model and installing your equipment will seem easier, since you will know where you are going.

WARNING

While this aircraft is an excellent first choice for novice pilots, a radio-controlled model is not a toy and is not intended for persons under 16 years old. Keep this kit out of the reach of younger children, as it contains parts that could be dangerous. A radio-controlled model is capable of causing serious bodily injury and property damage. It is the buyer's responsibility to build this kit correctly and to properly install the motor, radio, and all other equipment. Test and fly the finished model only in the presence and with the assistance of another experienced R/C flyer. The model must always be operated and flown using great care and common sense, as well as in accordance with the Safety Code of the Academy of Model Aeronautics (5151 Memorial Drive, Muncie, IN 47302, 1-800-435-9262). We suggest you join the AMA and become properly insured prior to flying this model. Also, consult with the AMA or your local hobby dealer to find an experienced instructor in your area. Per the Federal Communications Commission, you are required to use only those radio frequencies specified "for Model Aircraft."

Mirage 550

CARL GOLDBERG PRODUCTS, LTD.

P.O. Box 88 Oakwood GA 30566 Phone #678-450-0085 Fax # 770-53-63 www.carlgoldbergproducts.com

ITEMS NEEDED TO COMPLETE THIS KIT

- 1 RADIO GUIDANCE SYSTEM (2-3 CHANNEL MINIMUM REQUIRED, 4 CHANNEL RECOMMENDED)
- 1 6 CELL 7.2v BATTERY PACK (1500 -1900 MAH)
- 1 2 OZ. BOTTLE CA GLUE

- 1 EPOXY
- 1 TUB Balsa-TINTED CGP FILLER
- 2 ROLLS COVERING
- FUEL-PROOF PAINT FOR COWL AND WHEELPANTS
- 1 BATTERY CHARGER

NECESSARY TOOLS AND SUPPLIES.

- MISCELLANEOUS RUBBER BANDS, INCLUDING SEVERAL #64
- WAXED PAPER
- MODELING KNIFE AND RAZOR BLADES
- SANDPAPER (ASSORTED GRITS, INCLUDING COARSE (80), MEDIUM (150) AND FINE (220-320))
- SANDING BLOCK
- "T" PINS (at least 75)
- FLAT BUILDING BOARD (24" x60") SOFT ENOUGH TO PUSH PINS INTO
- ELECTRIC DRILL AND ASSORTED DRILL BITS
- SCISSORS
- SMALL SCREWDRIVER
- MASKING TAPE
- LONG NOSE PLIERS
- COVERING IRON AND HEAT GUN

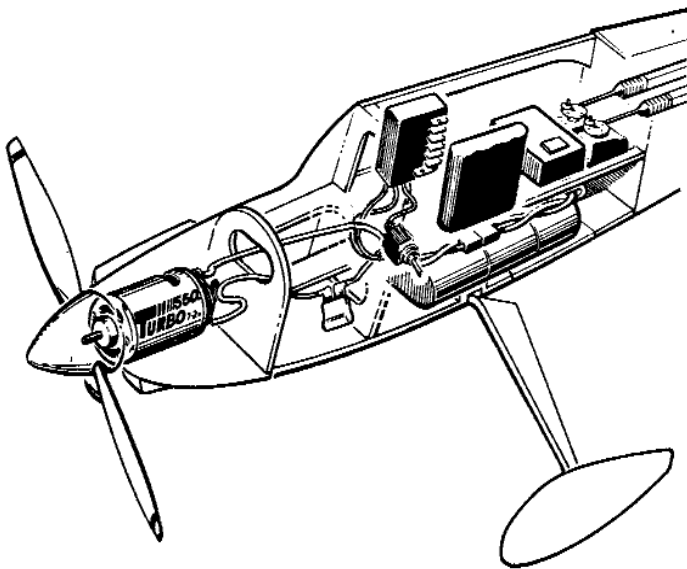

ELECTRONIC SPEED CONTROL OPTION

If you will be using a three-channel radio system, an electronic speed control gives you variable motor speeds. You can select any power setting: full power for take-off and climb-out, half power for lazy cruising, or cut power to glide in for landing. The speed controller replaces the third servo that would normally be connected to the motor "on-off" switch. You also save some weight, because the controller is lighter than the servo and pushrod. Speed controllers are somewhat expensive, but having one will add a lot to your flying enjoyment.

There are many good speed controllers on the market. Even those designed for R/C cars will work well in your **Mirage**. The most important thing in selecting a speed controller is that it must be able to run continuously for at least five minutes at 15 to 20 amps. Ask your hobby dealer for advice. More installation information is given later in this book.

An experienced R/C flight instructor is strongly recommended for learning how to fly.

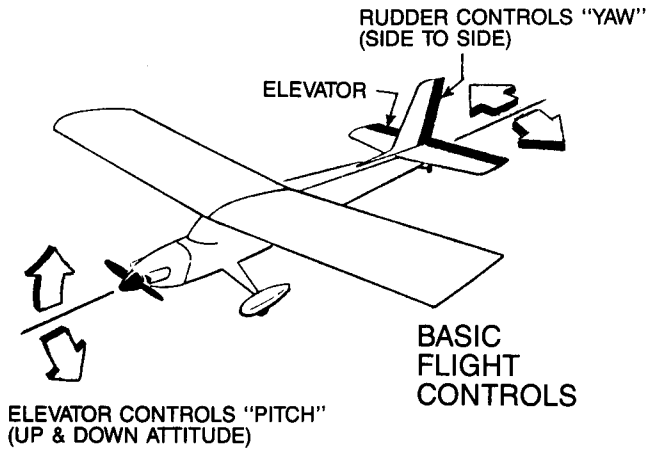

SELECTING RADIO CONTROL EQUIPMENT

The Mirage was designed to fly on two or three-channel radio control equipment. A two-channel system gives you two separate controls; one channel is used for the rudder which controls left and right direction, a second channel operates the elevator, which controls climbing, level flight, and descent. A three-channel system provides you with control of the motor: either on/off with the switch that is included in the kit, or "variable speed" with an optional electronic speed controller available from various manufacturers.

We recommend you purchase a 4 (or more) channel system with at least three servos and use the third channel for on/off control. Not only is the added dimension of motor control much more fun, but landings are much easier since you can "go around" if your first approach is not as good as you want. Also, by purchasing a 4-channel set now, you will not need to get one as you move up to more sophisticated models.

Radio sets are battery powered with either dry cells (small flashlight type batteries) or more reliable rechargeable nickel-cadmium batteries (ni-cads). Sets powered with ni-cads come equipped with a recharging unit, and are more expensive than dry-cells sets. However, if you intend to do a lot of flying, the cost of routinely replacing worn out dry cell batteries will be much greater than the higher initial cost of a re-chargeable ni-cad radio system; something to consider. Many of the radio systems now available feature "servo reversing" switches which allow you to reverse the response of the servo. This feature simplifies radio installation and is a worthwhile consideration when selecting a radio system. You may find radios with more sophisticated features such as dual rates, exponential and control mixing, etc. These features are not needed for general sport flying, and are typically used by more advanced flyers.

When selecting a radio, remember that there are many radio frequencies available. Not all of these frequencies can be legally used to operate model airplanes. Tell your dealer that you want a radio with a model "Airplane" frequency.

WARNING: Per the Federal Communications Commission, there is only one group of frequencies for radio control aircraft use. According to the law, it is your responsibility to use the designated aircraft frequencies to operate your model airplane.

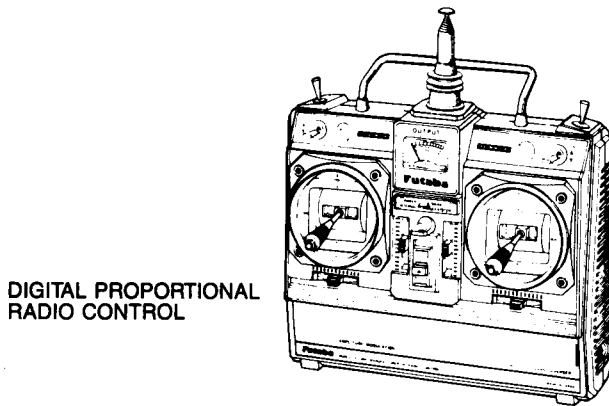

DIGITAL PROPORTIONAL RADIO CONTROL

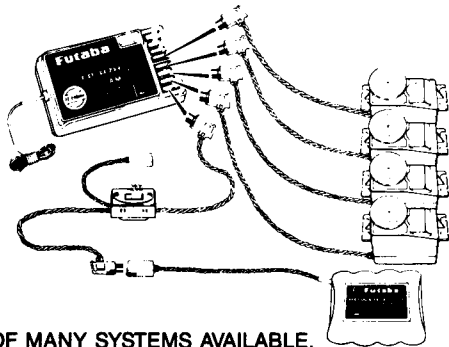

ONE OF MANY SYSTEMS AVAILABLE, PLEASE SEE YOUR LOCAL DEALER OR CLUB FOR ADVICE ON SELECTING YOUR RADIO.

The number of channels your radio control set has will determine how many controls you can use in your model.

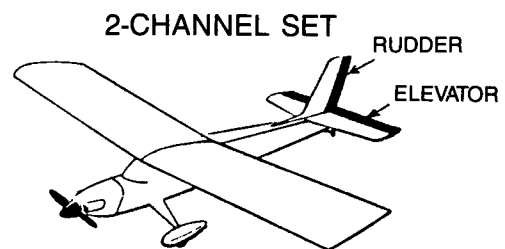
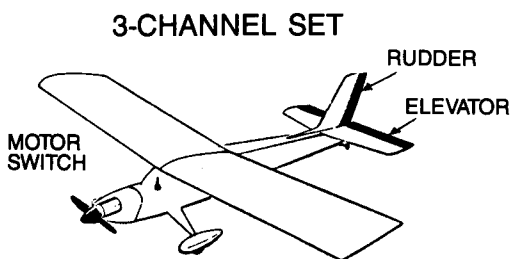

MOTOR & PROPELLER

We include the Carl Goldberg TURBO 550 Motor with your Mirage because it has the best performance/value ratio. It will provide you with a good climb for 4 minutes or more, on a standard 6-cell battery and an 8-4 prop. If you don't mind spending more, you can power your Mirage with a power unit such as the Challenger 05 Flight System manufactured by Astro Flight with similar results. For the ultimate in performance select a cobalt motor, again such as an Astro Flight system. There are geared systems which will give even more thrust but you may want to reserve that type of power plant for a competition type plane.

The Turbo 550 Motor System is equipped with an in-line fuse. Without a fuse, the motor or battery could be permanently damaged if the prop is stalled or jammed while the motor is running. If you will be using another brand of motor make sure it has a fuse—if it doesn't, ask your dealer how to install one. It isn't that difficult.

An 8-4 nylon propeller is included in the kit—the best all around prop with the TURBO 550 Motor. Some wooden 8-4 props may give better climb. If you use a geared or cobalt motor please refer to manufacturer's recommendations.

HOW MANY BATTERIES?

To get in the most flying each session we suggest you purchase three battery packs. While one pack is cooling and waiting to be charged, a second pack can be on charge and the third can be in your plane ready for use. Of course, you can fly with only one pack, but you may have to wait up to 40 minutes between flights.

BATTERY CHARGERS

There is quite a selection of chargers available and most work quite well. For the best advice, see your dealer. If you can't, here is a brief description of the various stypes of charges and how they work.

Some chargers use 12 volts, as does a car battery, while others use 120 volt house current. Some will work on both. Most quick chargers charge in 20 minutes or less. A handy, though not mandatory accessory for your charger is a digital voltage meter.

BASIC CHARGERS—With a Mechanical Timer. This type works well but must be used with care to avoid overcharging your batteries. Generally they are the least expensive.

AUTOMATIC WITH DELTA (PEAK) DETECTION. Generally more expensive but very easy to use—just hook up and come back in 20 minutes. They usually operate only from a 12 volt power supply.

AUTOMATIC WITH HEAT SENSOR. Generally the most expensive and work very well. Simply plug in and come back in 20 minutes. Battery must be cool before start of charge cycle. These chargers are available in 12, 120, and 12/120 volt power requirements.

Additional information on batteries and chargers is found in the "Balancing & Flying Your Model" section later in this book.

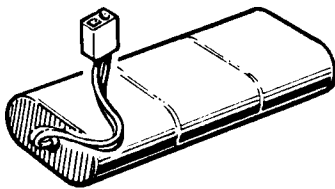

INTRODUCTION

USING THIS INSTRUCTION MANUAL

Before you start gluing and sanding, take some time becoming familiar with the plans and looking through this entire Instruction Booklet. It is designed to guide you through the construction process step by step, so build in the order given in this book. Balancing, setting up and flying the model are also covered.

Like a full-size airplane, the **Mirage 550** is built from basic structures (stabilizer, fin, wing, etc.), which are then assembled into the complete airplane. Special procedures or comments will usually be explained before a step, so you will be prepared. If a step begins with a statement like "Note," "Warning," or "Important," it is a good idea to read through the step before doing it.

A check-off box appears at the beginning of each step. Check these boxes as you build, so you can tell at a glance what steps you have completed. Some steps are repeated and must be marked twice, as in the case of the left and right wing panel.

HOW TO READ THE PLAN

There is one plan sheet in this kit, showing the Fuselage (Body), the Wing, and the Tail Parts. Everything on the plan is drawn to full-size and shape and shows how the finished parts fit together.

The plan is drawn to show the model completely assembled, but as a result, the areas inside or underneath are covered up, making it hard to understand how these parts fit together. Therefore, for clarity, some parts are drawn with hidden lines, others with breakaway views, and some are entirely removed from the structure and shown separately.

For example, on the fuselage, the left side of the completed model has been removed to show the details inside. Sometimes a surface is broken away to reveal the detail behind or underneath. Dashed lines indicate details that are hidden behind or under another part of the surface.

FUSELAGE DRAWN WITH LEFT SIDE
REMOVED TO REVEAL INNER
FUSELAGE DETAILS

THE WING IS SHOWN CUT
THROUGH AT THE CENTER—
THIS IS A "SECTION" VIEW

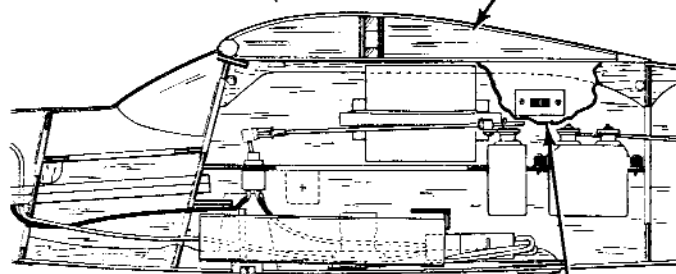

DASHED LINES SHOW
WIRES "HIDDEN"
BEHIND BATTERY

FUSELAGE SIDE
"BREAK-AWAY" VIEW
TO SHOW HOW SWITCH
IS MOUNTED

The model is made from four varieties of wood: balsa, bass, birch, and various plywoods. Each kind of wood has its own characteristic *end grain pattern* (as viewed from the end) which has been drawn on the plan. You can easily use these end grain patterns to identify what kind of wood is shown for a part, if you are in doubt.

HOW TO USE THE PLAN

The plan is used in several ways. The wings, stabilizer, and fin are assembled directly over the plan. Each wood part is matched over its corresponding location printed on the plan and pinned in place. To prevent ruining your plan from gluing your wings, etc. to it, cover the area you are working on with waxed paper.

The paper the plan is printed on can expand or contract slightly with changes in temperature or humidity. Because of this, a pre-formed part such as the notched wing trailing edge may not exactly match the plan. This is no problem, as slight deviations in the outline or size will not noticeably affect flight performance.

Because the fuselage plugs together and is self-aligning, it is not built directly over the plan. As you assemble the fuselage, you will find the plan helpful in identifying parts and how things fit together.

The plan also shows the installation of a typical radio, battery and all remaining equipment and hardware needed to complete the model. By referring to the examples shown, you should be able to install your own radio, etc., even if it is not the same as what is shown on the plan.

IDENTIFYING PARTS

Parts for the wing are bundled together; likewise, parts for the tail assembly are also grouped. Die-cut plywood and balsa sheets of common sizes are bundled together, so they are less likely to be damaged during shipping and handling. The various screws, hinges, and fittings are packaged in plastic bags.

PREPARING FOR ASSEMBLY

Set a flat, warp-free pinning board on your work bench. Any material that accepts pins, such as insulation board, soft plywood, or dry-wall (sheet rock) will work. **Important: any warps or bends in the pinning board will result in wings or tail surfaces that are also warped or bent, making your model more difficult to fly.** Make sure that the pinning board is flat by laying a straight edge across it. You may be able to correct a warped board by shimming its low areas.

Position the area of the plan (such as the stabilizer) on which you are going to build over the pinning board and tape it in place so the plan lays flat and wrinkle free.

Place a sheet of waxed paper over the work area to prevent **SUPER JET** from sticking to your plan and ruining it.

CONSTRUCTION TIPS

In assembling your model, the following tips will prove helpful. **IMPORTANT: ALWAYS READ A FEW STEPS AHEAD.** This will alert you to coming instructions and will help you plan accordingly.

You may find it convenient to empty all of the small parts from the hardware bags into a common container, such as a margarine tub. This will help you find items quickly.

Punch out only the die-cut (D/C) parts you need as you proceed. This will help you keep track of parts, especially the small ones.

After completing each section of the aircraft, you may want to go back and re-glue the joints, just in case some area has been missed. Be careful not to use too little glue, which will leave the model weak, or too much glue, which can make the model heavy. Properly glued joints are important to the overall strength of the model. **SUPER JET™** is recommended for most parts of the assembly, although **JET Epoxy** may be used when more time is needed for careful placement.

WOOD PARTS IDENTIFICATION

Be careful when removing parts (such as fuselage sides) from die-cut sheets. Long parts are fragile until glued into a structural unit. If necessary, use a razor knife or razor saw to assist in the removal of parts from sheet. Sometimes a little trimming and sanding can improve parts where desired. Save scrap until model is completed, in case you should miss a part. Scrap is used also in some building steps on the plan. Other easily recognized parts, such as motor bearers are not shown here.

ABOUT THE WOOD IN THE KIT

We strive to supply good quality materials in your kit. Wood parts are inspected with regard to the function they will serve. If an imperfection is spotted in a scrap corner of a die-cut sheet and doesn't affect actual parts, the sheet is considered acceptable. Also, internal stresses in wood are relieved as it is cut into parts. These relieved stresses may cause some parts to bow. Bows in wood parts (such as leading edges) readily straighten out as they are glued into a structural unit.

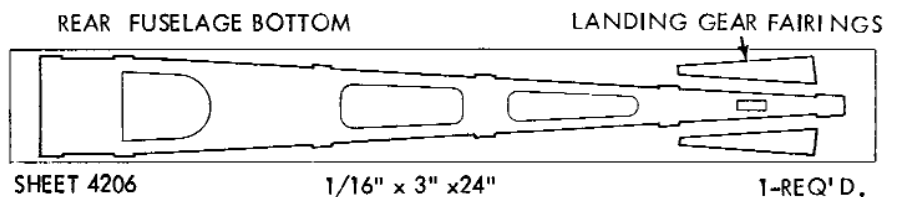
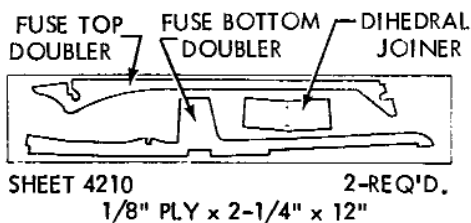
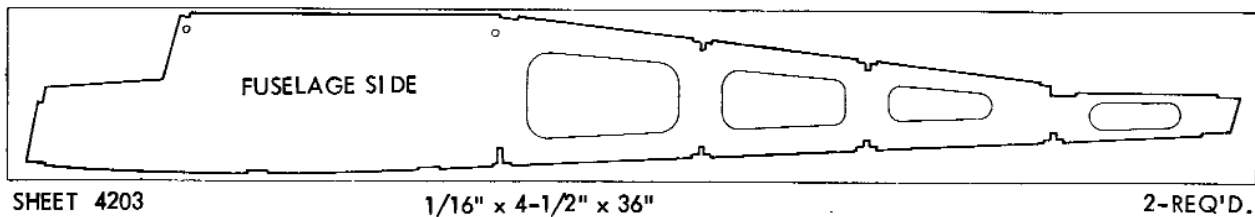
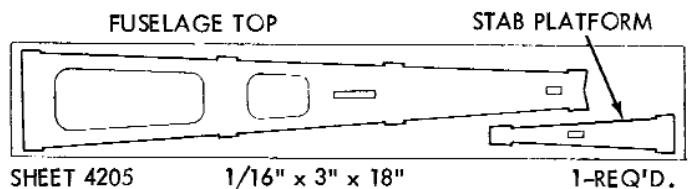
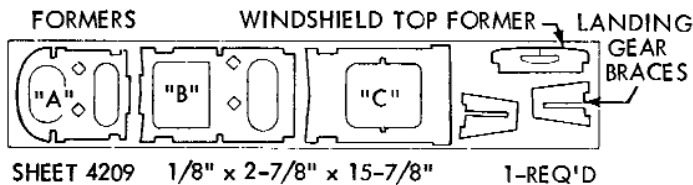
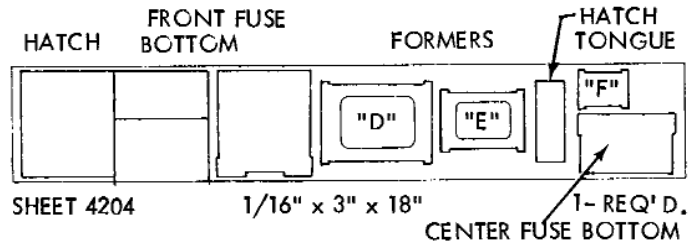
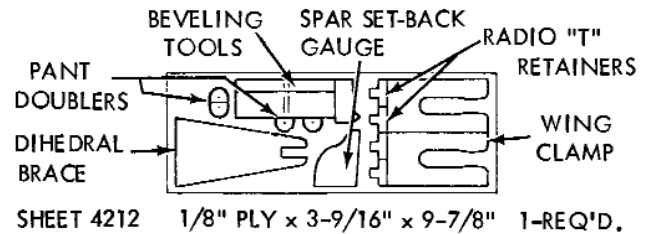
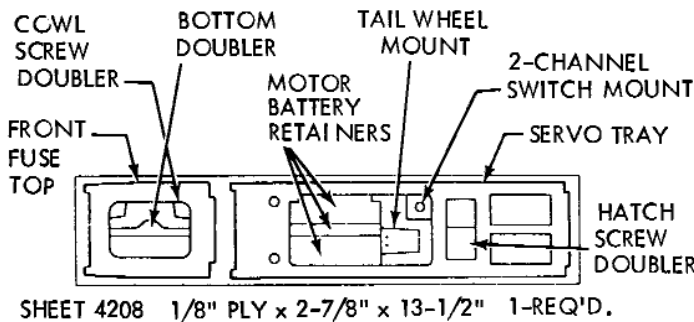
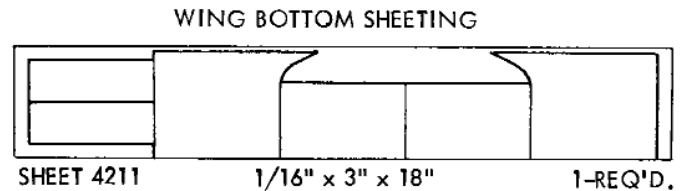
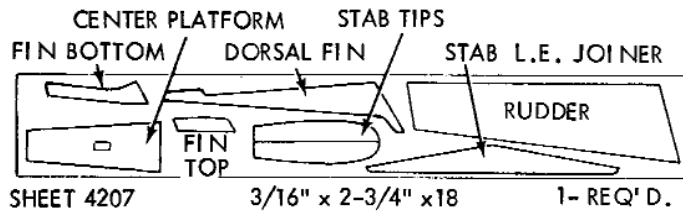
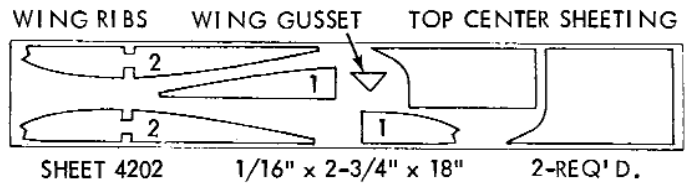
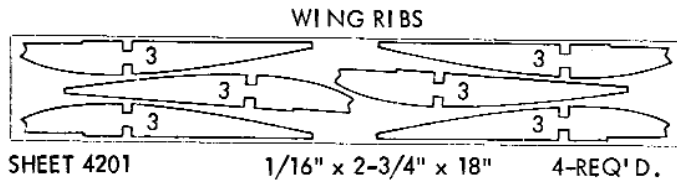

MAJOR PARTS & COMPONENTS
SHOWN HERE BEFORE COVERING

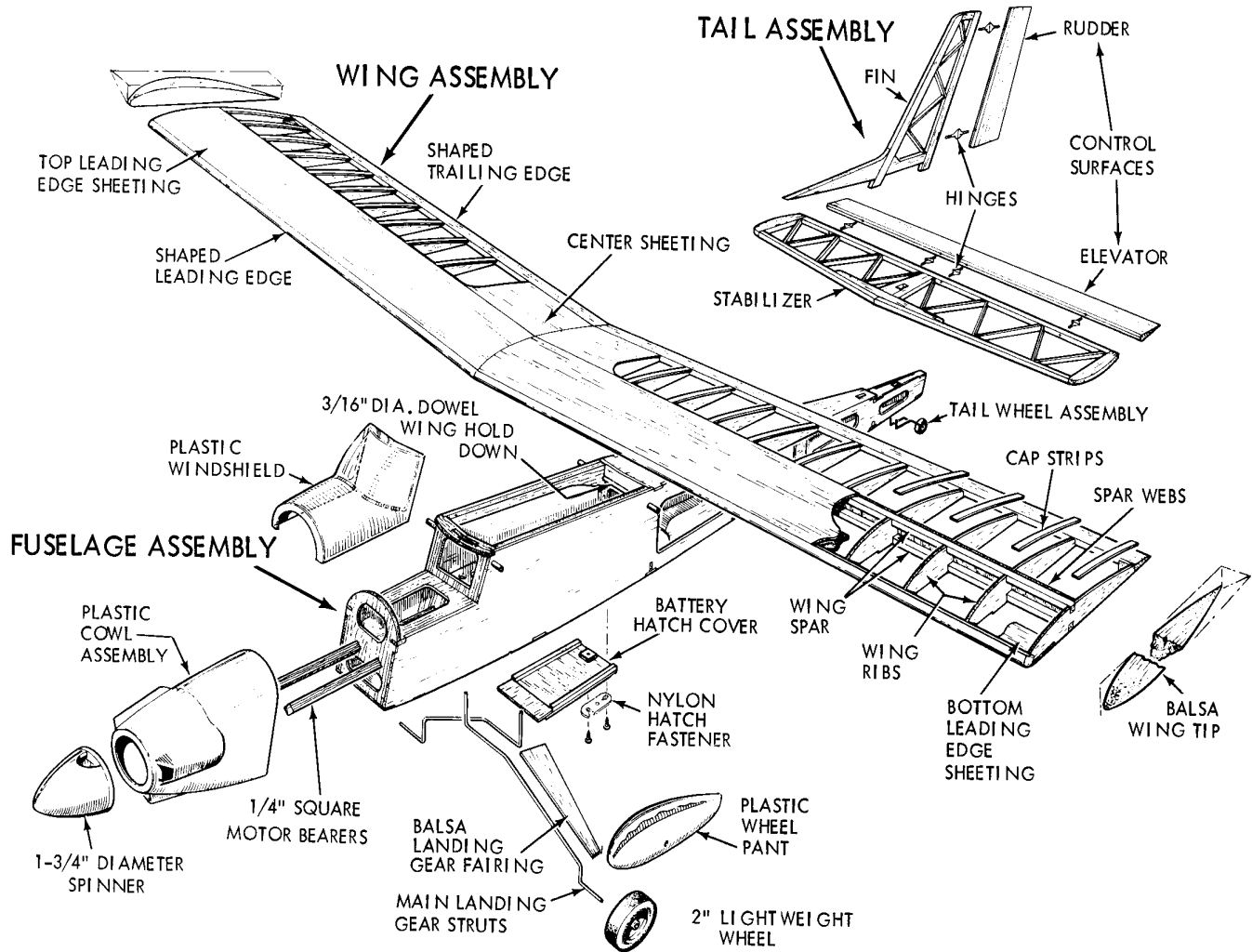

TAIL ASSEMBLY

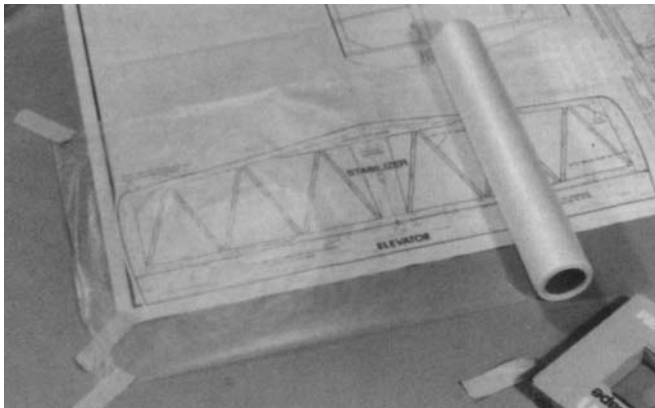
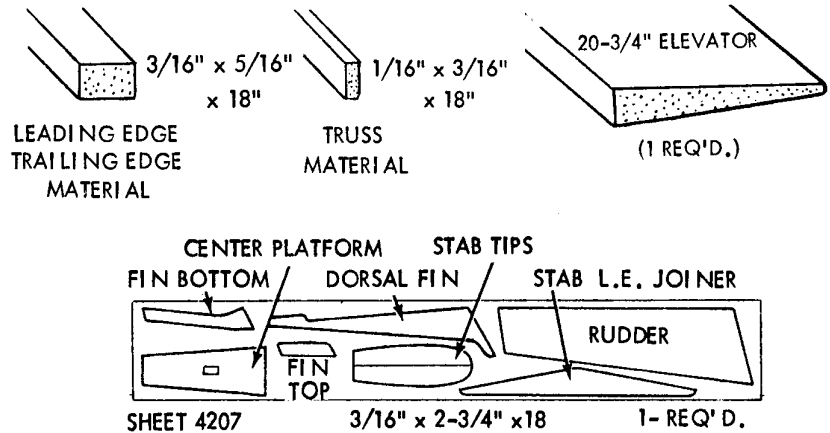
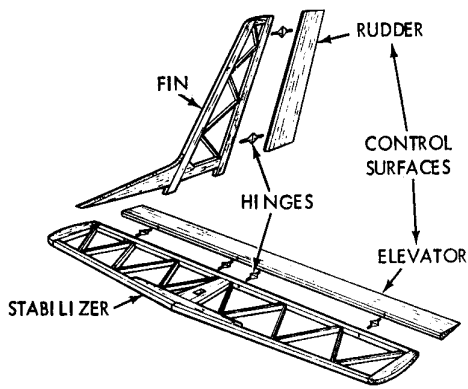

- Set your flat warp-free pinning board on work bench.
 - Tape Mirage plan so stabilizer (stab) is in position over pinning board.
 - Tape a sheet of wax paper or plastic kitchen wrap over stab area to prevent gluing parts to the plan as you build.

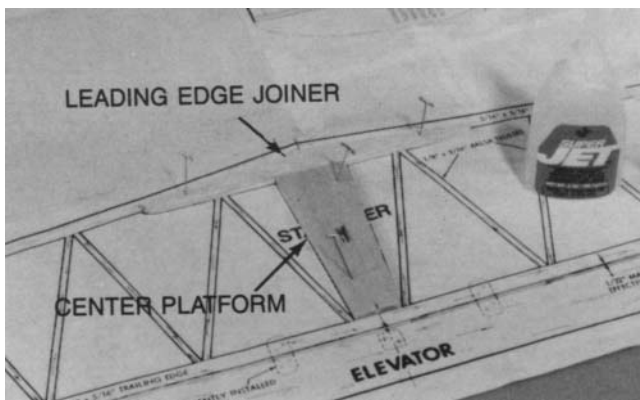

- Carefully position die-cut leading edge joiner and center platform and pin in place over the plan. Glue these parts together using Super Jet (Thick C.A.).

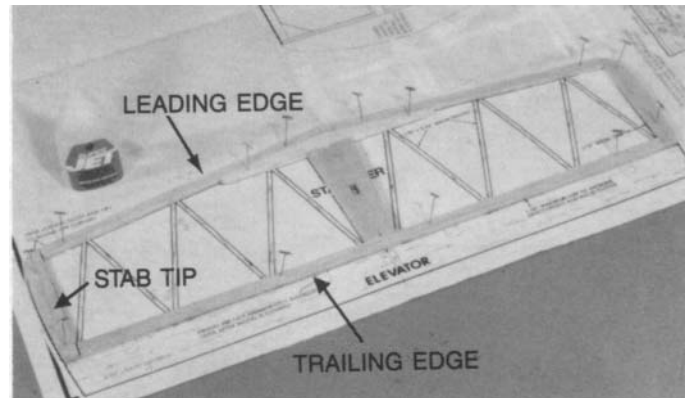

- Make stab leading edge (L.E.) from $3/16'' \times 5/16''$ balsa sticks. Cut balsa carefully to match with plan at center joint.
 - Pin in position and glue to L.E. Joiner.
 - Make stab T.E. from $3/16'' \times 5/16''$ balsa. Cut to match length shown on plan and glue to T.E. joiner.
 - Complete stab outline by gluing die-cut balsa stab tips in place.

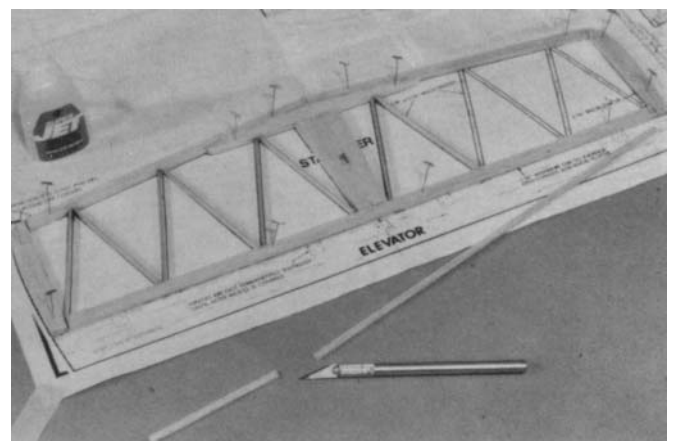

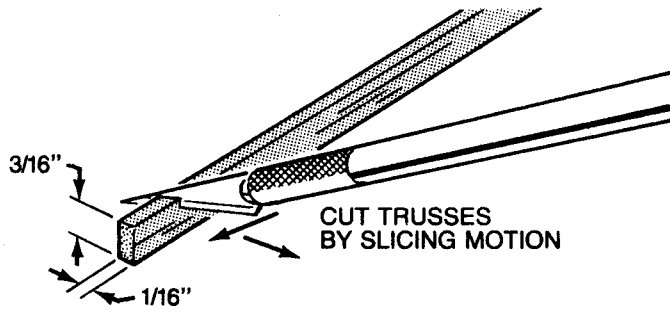

4. From 3/16" x 1/16" strip balsa, cut all trusses to size over plan. Working one-at-a-time, trim to fit well—don't force into place. Glue in place.

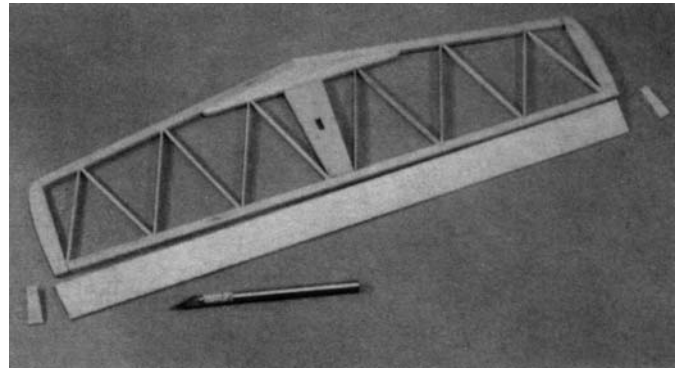

- Cut elevator at marks to match stabilizer tips.

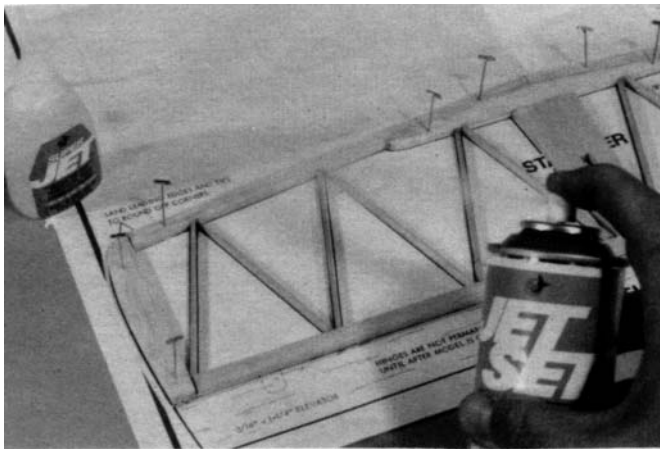

Jet Set makes all brands of CA glue dry faster. Use Jet Set on corner joints for extra-strong fillets.

- Let dry thoroughly.

NOTE: Jet Set now comes in a pump spray bottle.

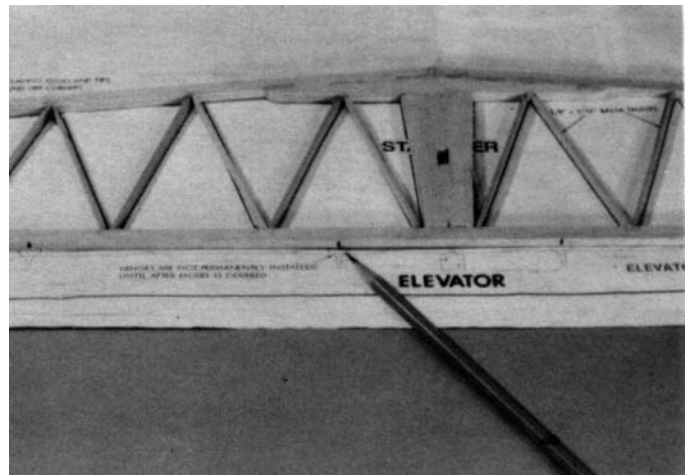

6. Transfer hinge locations from plan to T.E.

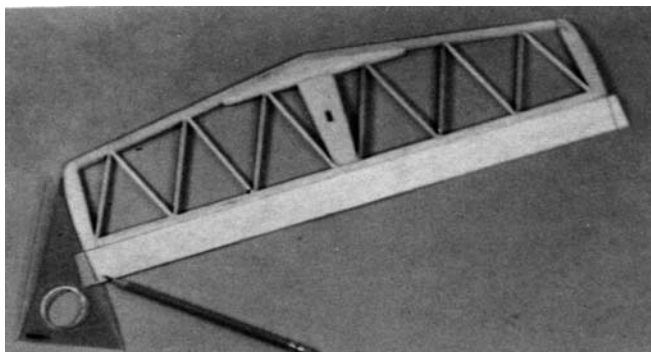

5. Position balsa elevator against stab T.E. and mark elevator ends for match with stab tips.

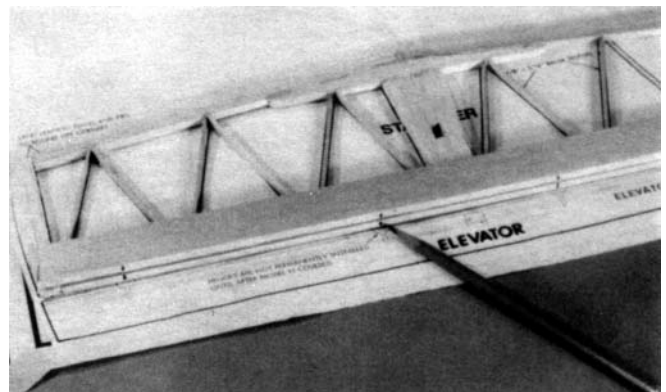

- Place elevator on top of T.E. and transfer hinge locations to elevator.

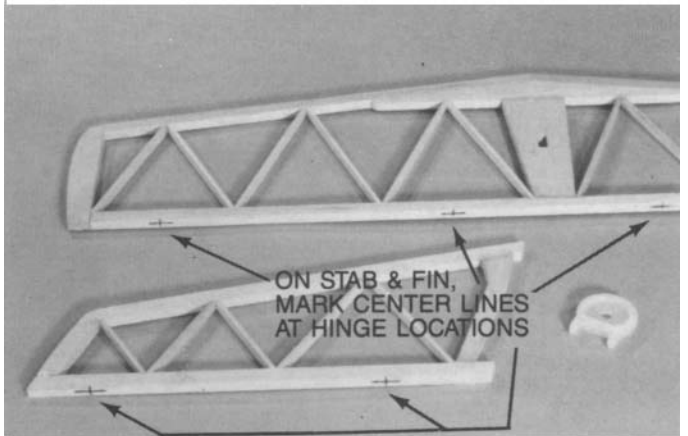
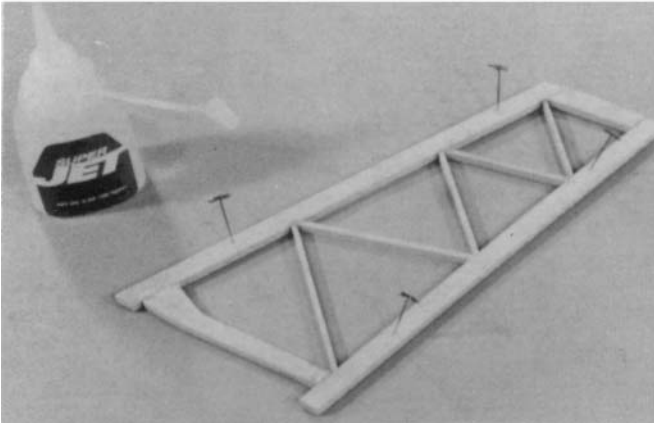
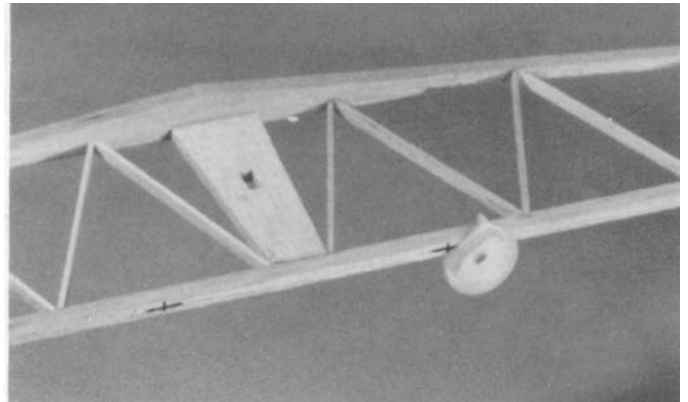
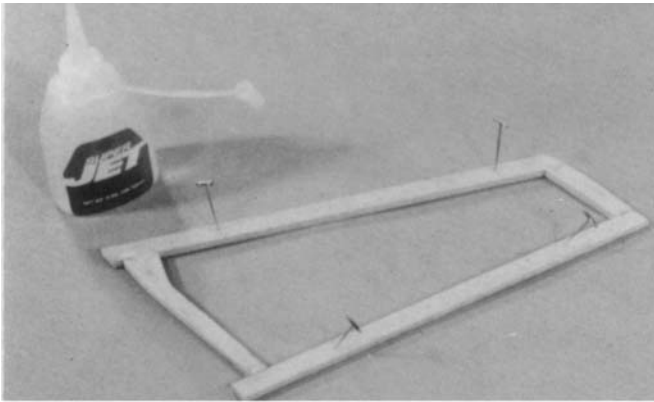

7. Assemble the fin in the same manner as stab. Let dry.

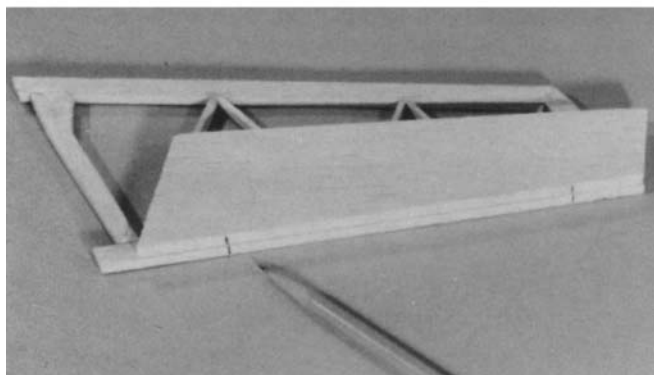
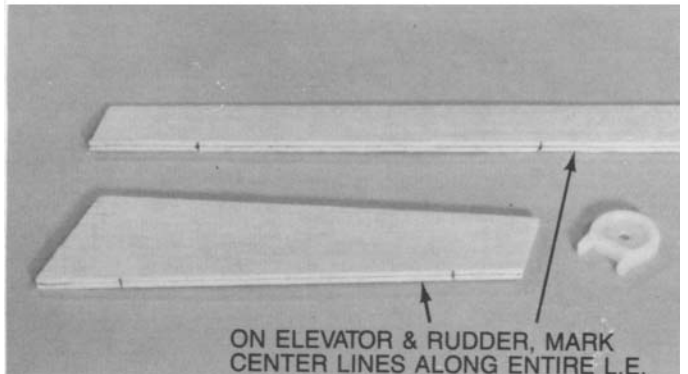
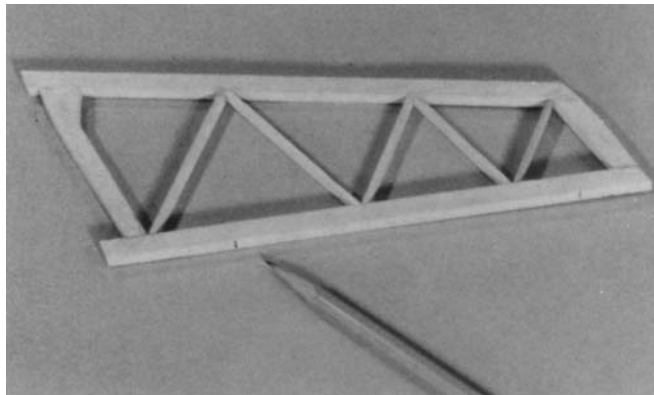

9. Using the CG Center-Line Marker provided, mark center lines along edges of parts as shown. Tilt marker so guide pegs touch the wood, then lightly pass the marker back and forth. Point will scribe center line.

8. Mark hinge locations on fin and rudder.

Note: in the next few steps the hinges will be TEMPORARILY installed—they are not permanently installed until after the model is covered.

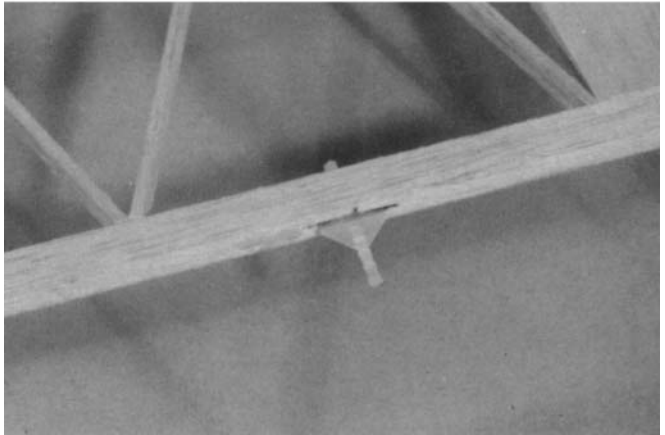
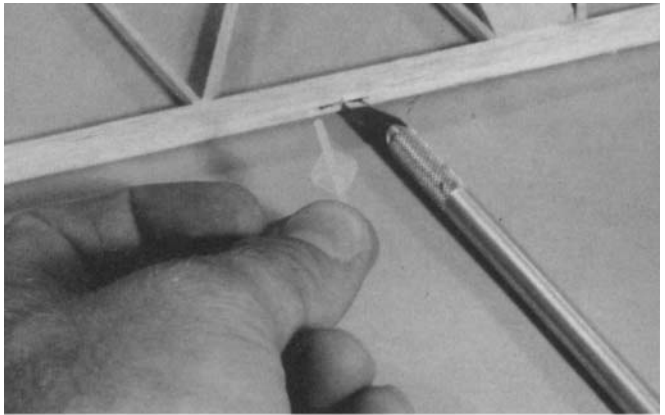

10b. After drilling, use a razor knife to make clearance slits for hinge webs. Temporarily insert hinges.

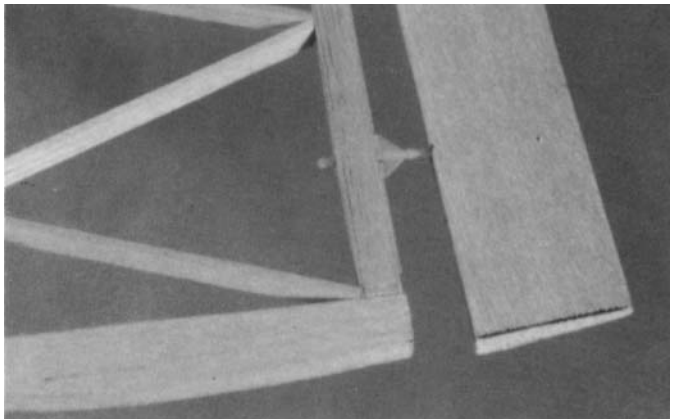

11a. Repeat drilling and slitting for elevator—Caution; keep drill centered in elevator.

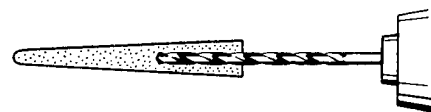

ELEVATOR END VIEW TO SHOW DRILL BEING CENTERED IN ELEVATOR

11b. Temporarily fit elevator on hinges.

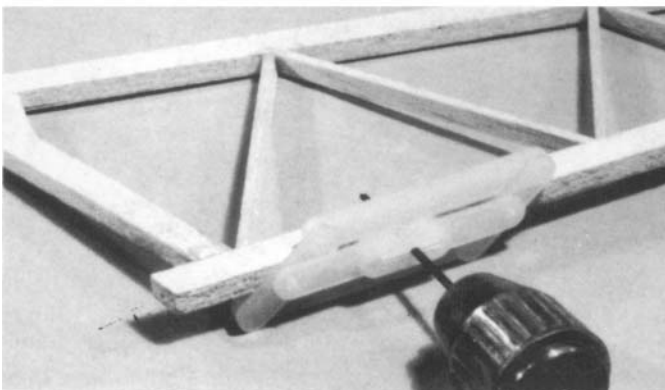
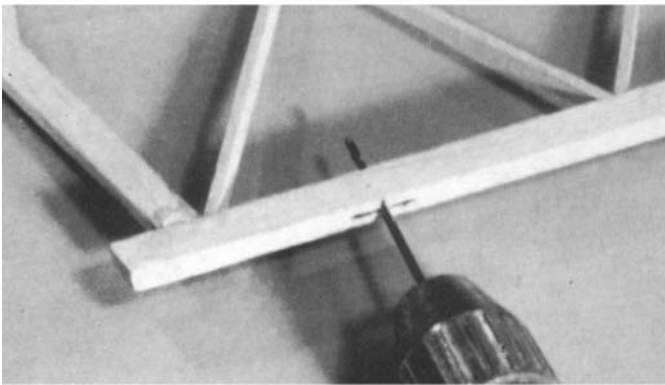
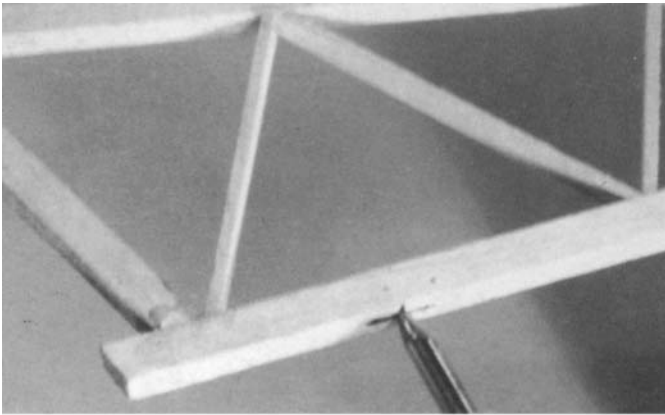

10a. At hinge locations, press a nail point to start holes. Then carefully drill four 1/16" diameter holes through stab T.E. at hinge locations. Try to keep drill centered, not up, down or off to a side. The optional CG Hinge Drilling Guide (not included) makes these drilling alignments automatically.

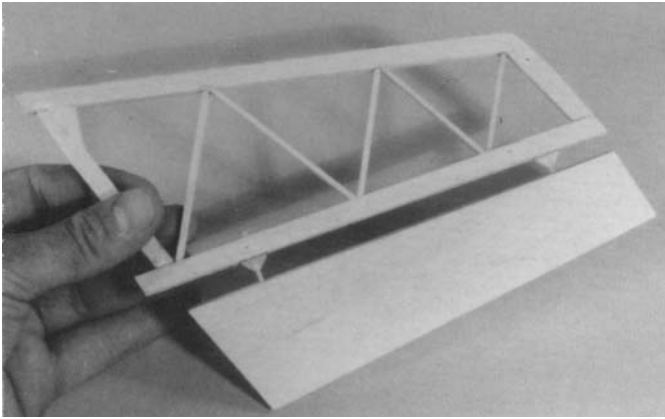

12. Repeat drilling and slotting method in steps 10 & 11 for fin and rudder.

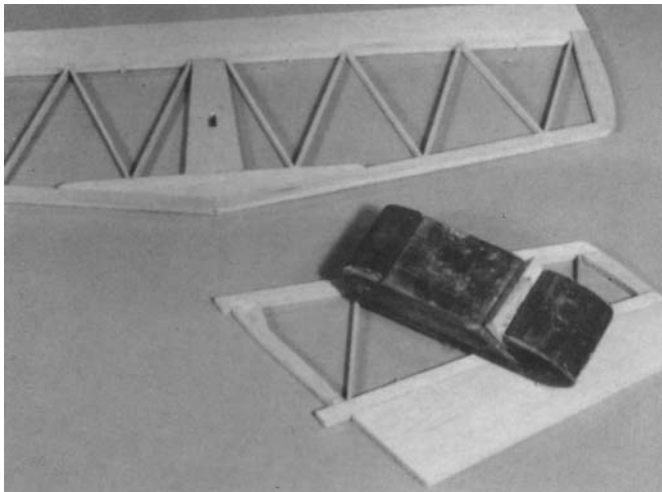

13. Sand flat the fin and stab to flush the trussing with the leading and trailing edge. Now round the L.E., T.E. and tip to an air-foil shape as shown on plan.

ASSEMBLING DIE-CUT BEVELING TOOL (FROM 1/8" PLY)

Parts for two tools are furnished — only one is used.

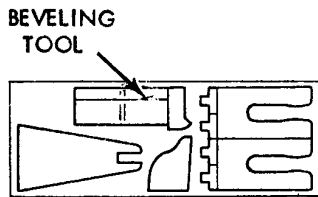

SHEET 4212 1/8" PLY x 3-9/16" x 9-7/8" 1-REQ'D.

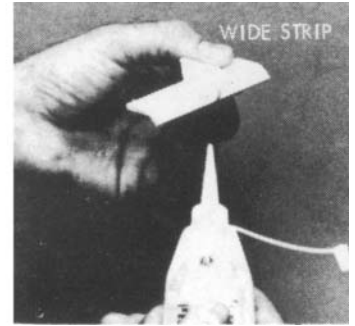
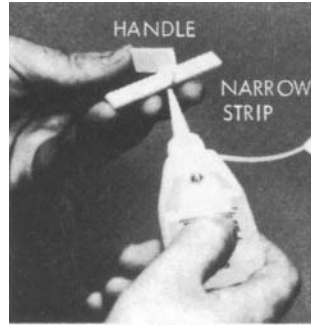
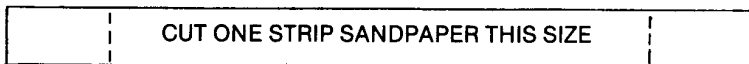
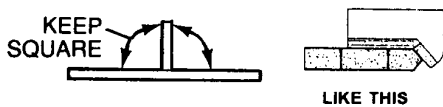

- 14a. First glue narrow strip to handle, keeping them square, as shown. Then glue wide strip to handle and narrow strip, again keeping things square.

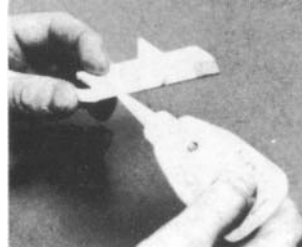

- 14b. Cut one strip of 100-200 grit sandpaper to size shown above. Glue sandpaper to tool.

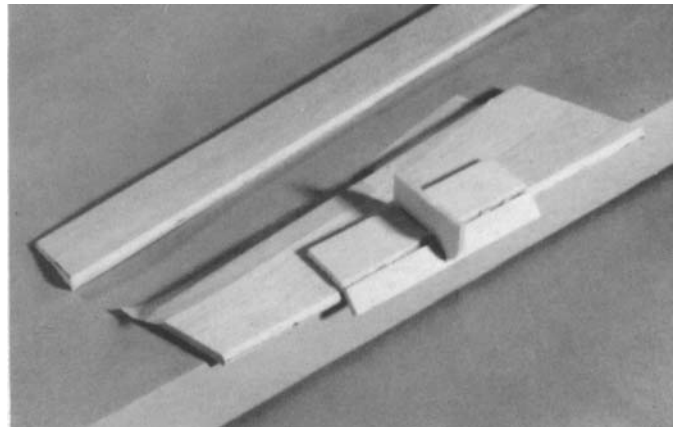

15. Tape T.E. of elevator and rudder to work surface. Using beveling tool, sand L.E. to center line. Turn parts over and repeat beveling for other side.

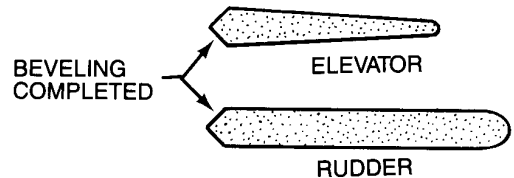

THIS COMPLETES THE TAIL ASSEMBLY CONSTRUCTION.

WING PARTS

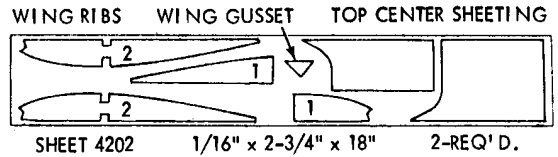
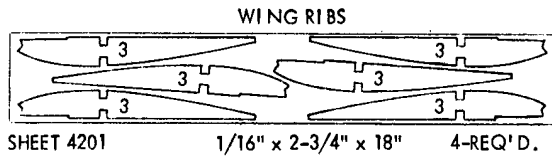

SHEAR WEBS
SHEET 4200
2-REQ'D

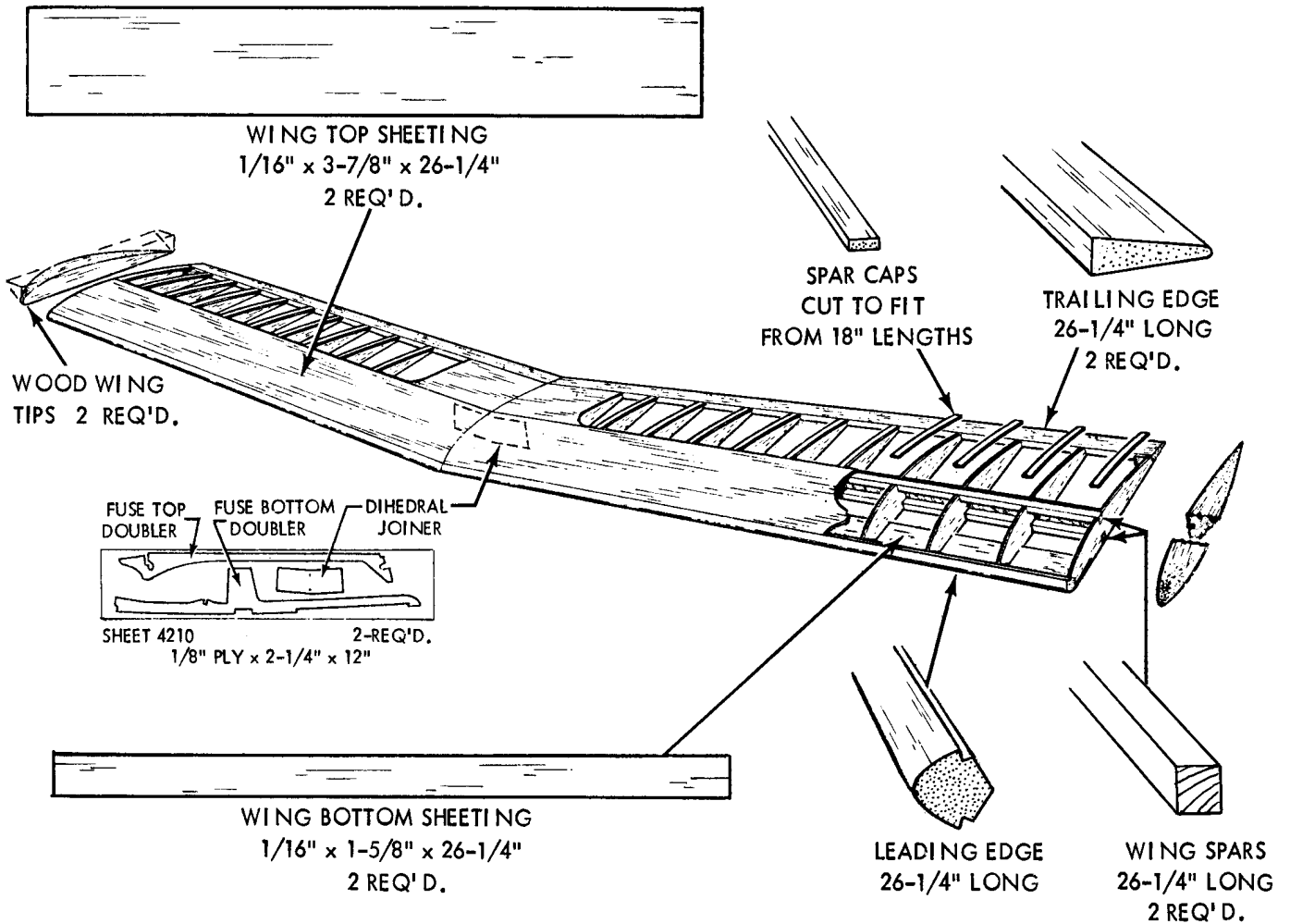
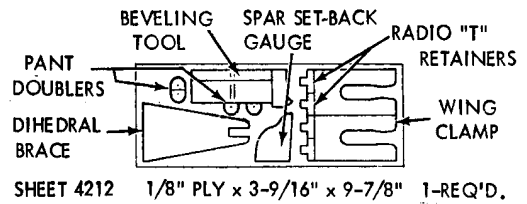
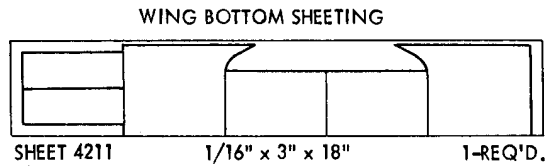

WING ASSEMBLY

SINCE THE WING IS BUILT IN TWO HALVES, AND STEPS 1 TO 10 ARE REPEATED IN THE PROCESS, TWO CHECK BOXES ARE PROVIDED WITH EACH OF THESE STEPS. ONE FOR THE RIGHT WING AND ONE FOR THE LEFT. THE RIGHT WING IS BUILT FIRST.

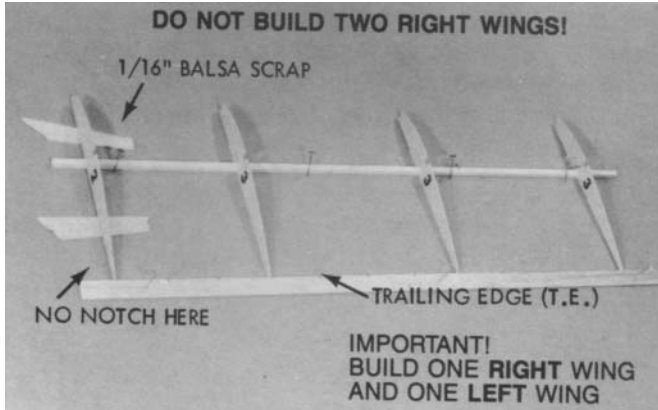

- Position one spar in place over RIGHT WING (or LEFT WING) on plan. Align spar end at center of wing on plan. Hold spar in exact position by cross-pinning at circled locations on plan. CAUTION; Do not build two RIGHT WINGS!

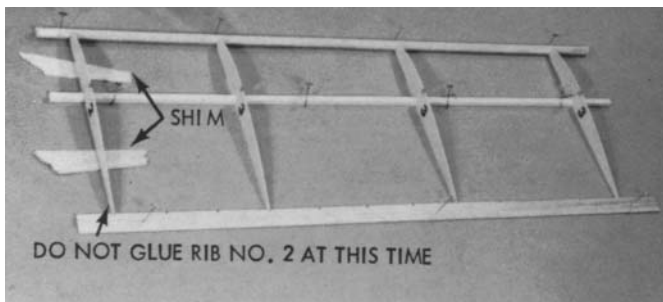

- Using **no pins**, set TRAILING EDGE (T.E.) in place on plan. **IMPORTANT:** The T.E. has no notch at one end—this unnotched end must be at the **wing center** as shown.

Using no glue, place the following four ribs in their respective T.E. notches: ribs nos. 2, 3, 3, & 3 hooking them over the spar as you go. Place rib wood scrap under rib 2 as a shim to level.

Align T.E. and ribs over plan, and pin in place. (Note: If a part appears not to "fit" the plan exactly, don't worry, this is due to expansion and shrinkage of the plan paper.)

Do not glue rib No. 2 at this time. Glue ribs No. 3 to T.E. and spar.

- Position 26" balsa LEADING EDGE (L.E.) in place over plan. Press L.E. into rib recesses, holding it tight with pins as you go.

ANGLE PINS BACK AGAINST L.E.

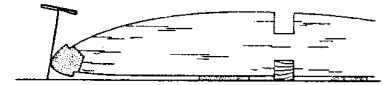

Do not glue Rib No. 2 at this time. Glue ribs No. 3 to L.E.

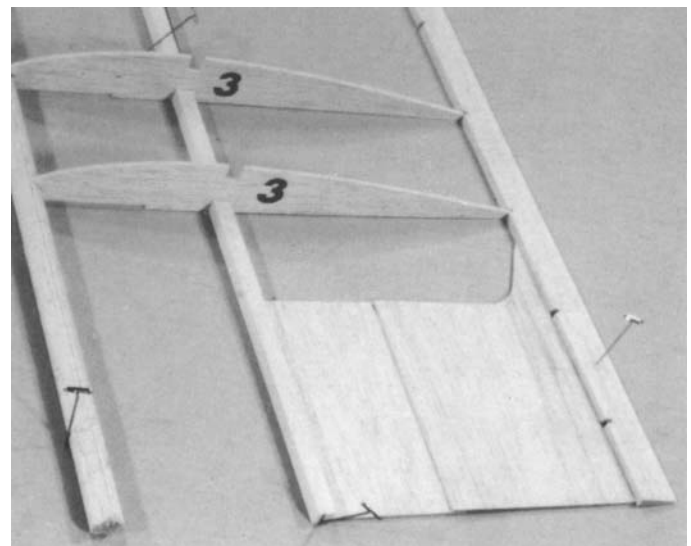

- Position one rear bottom sheet at rear of spar. Place other rear bottom sheet at T.E. so it overlaps the first one. Holding both sheets in place, trim first sheet even with edge of second sheet.

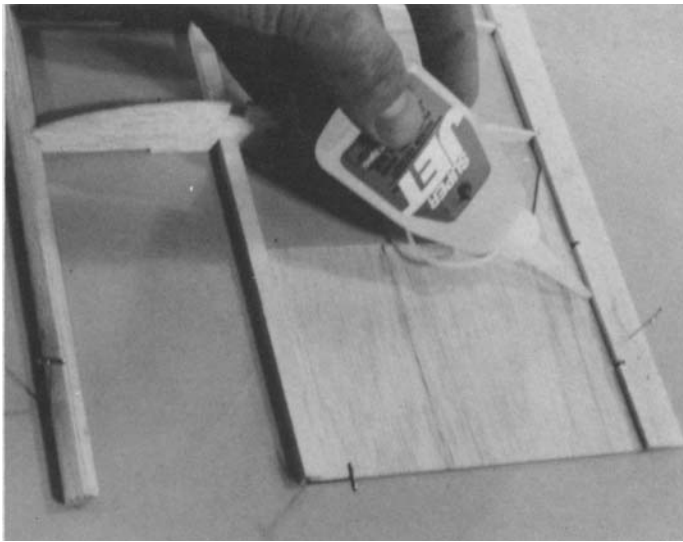

HOLD PARTS DOWN FLAT WHILE GLUING

5. Glue two rear sheeting pieces together, and to spar and T.E.

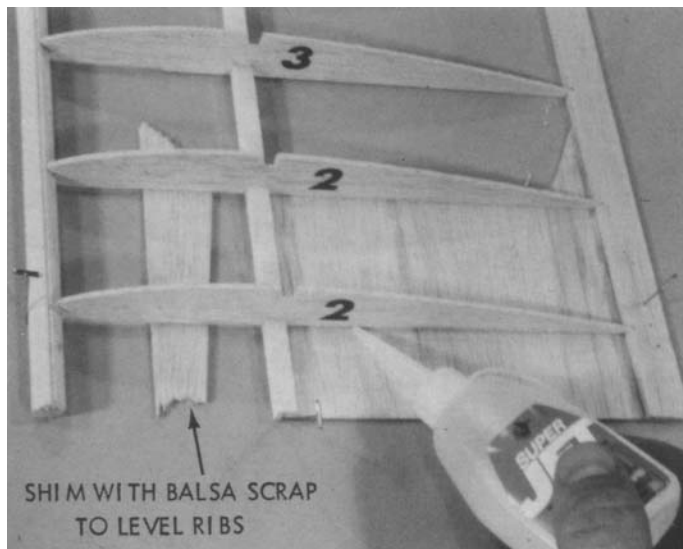

SHIM WITH BALSA SCRAP TO LEVEL RIBS

6. Position and glue ribs No. 2 & 3 to L.E., spar, bottom sheeting, and T.E.

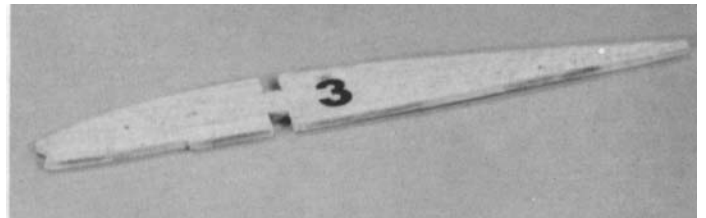
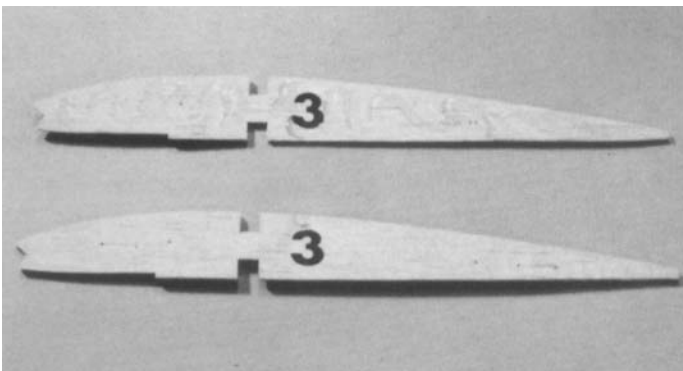

- 7a. A doubled rib is necessary at the wing tip. Glue two No. 3 ribs together: apply SUPER JET to one rib, stand them next to each other to check alignment, then press together.

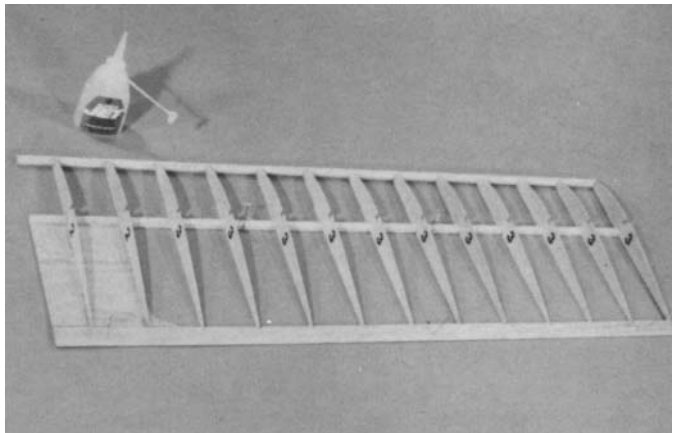

- 7b. Working one at a time, glue remaining ribs No. 3 to spar & T.E. only. Hold each rib up straight as it dries.

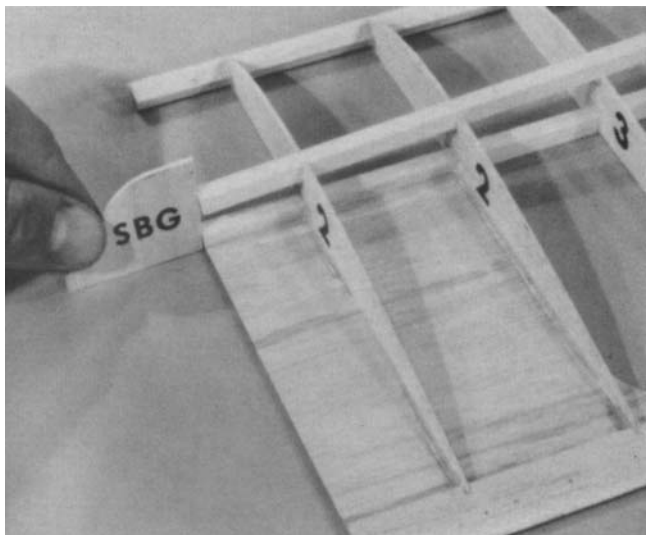

8. The pins holding the bottom spar may obstruct the top spar, so remove these pins. Reposition the pins through wing ribs if necessary to keep wing flat.

- Position the Set Back Gauge (SBG) touching the bottom spar. Touch end of top spar to gauge, and set spar in rib slots.

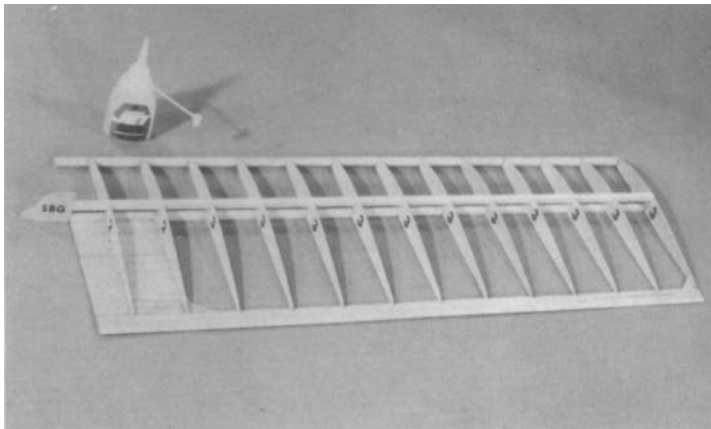

- Glue top spar to all ribs.
- Glue wing tip gusset to T.E.

10a. Continued

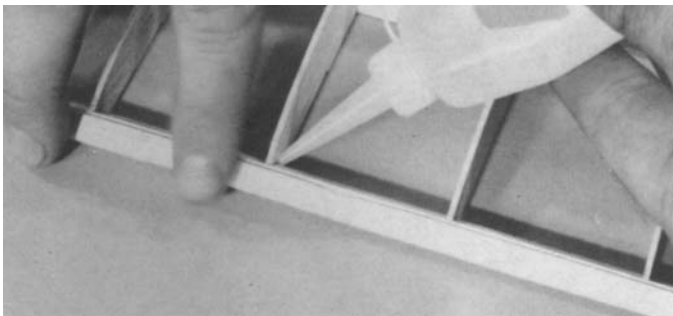
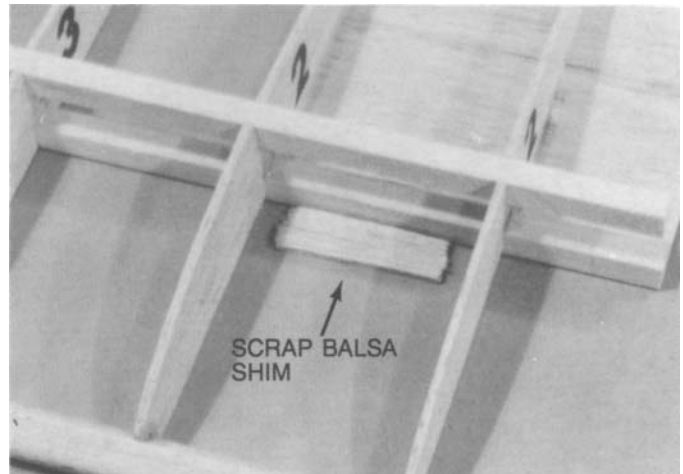

9. Working a few ribs at a time, apply SUPER JET to glue loose ribs to L.E. Gently squeeze L.E. into ribs and hold until set. Repeat until all ribs are glued to L.E.

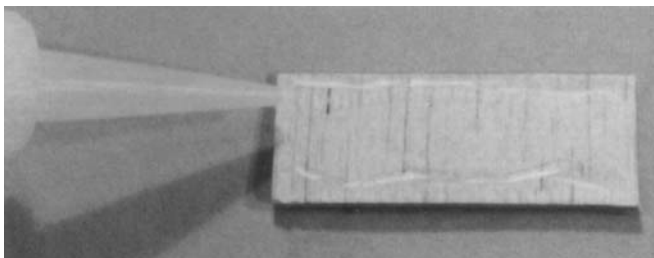

- 10a. Install shear webs in wing at positions shown on the plan as follows: Apply two lines of glue (near top and bottom), position webs equally on spars then press web up in place against spars until set. Important; the webs between ribs 2 & 2 and 2 & 3 must be raised slightly to provide clearance for bottom sheeting (installed later)—use wing rib scrap for shims under these webs.

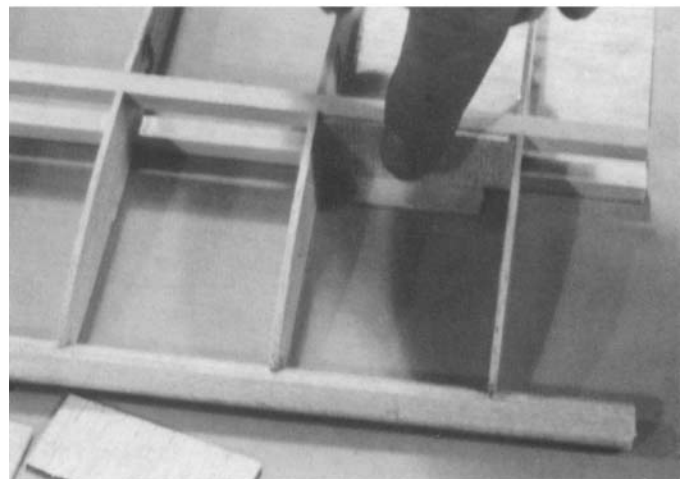

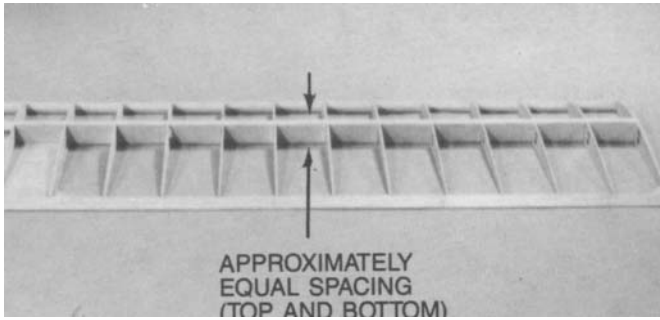

10b. Continue gluing webs to spars at locations shown on plan.

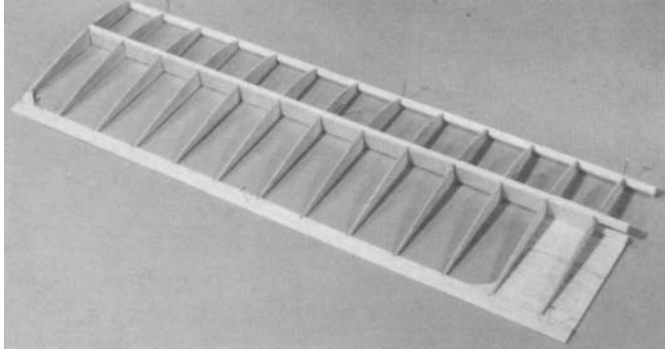

11. Repeat steps 2 through 10 for LEFT wing.

SUPPORT WING AT 3rd RIB FROM TIP

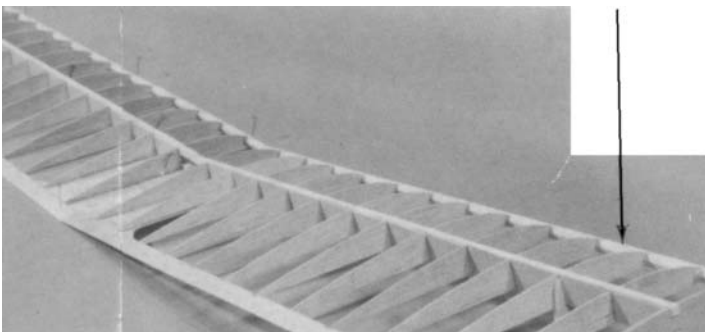

12. With left wing still pinned down, position RIGHT WING in place next to it. Raise RIGHT WING tip and support it at 3rd rib in from tip using dihedral gauge. Engage gauge top slot with spar.

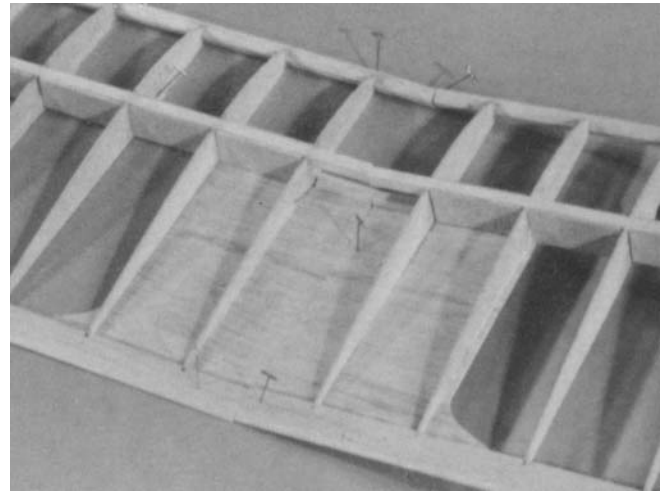

13. Study entire center joint; all end parts of right wing should just touch those of the left (tiny gaps are alright). If the fit between most parts is a little loose because one part protrudes too much, **slightly** sand only the protruding part for better fit. When sanding, it is better to take off too little than too much!

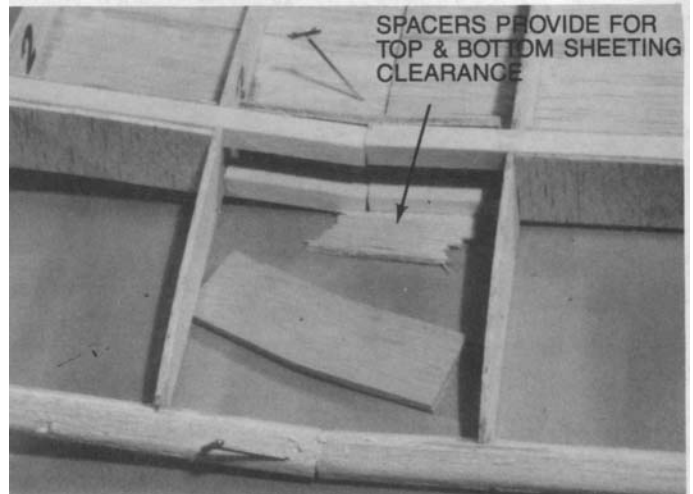

TEMPORARILY set dihedral joiners in place on each side of spars (for front joiner, use spacer underneath as shown). Use die-cut clamps provided to hold joiners tight against spars.

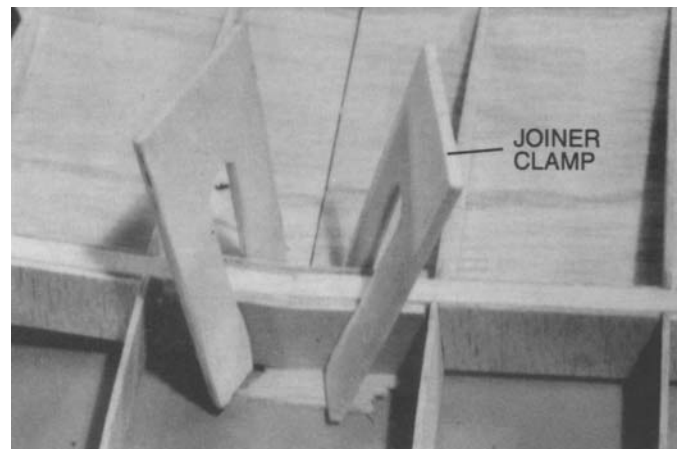

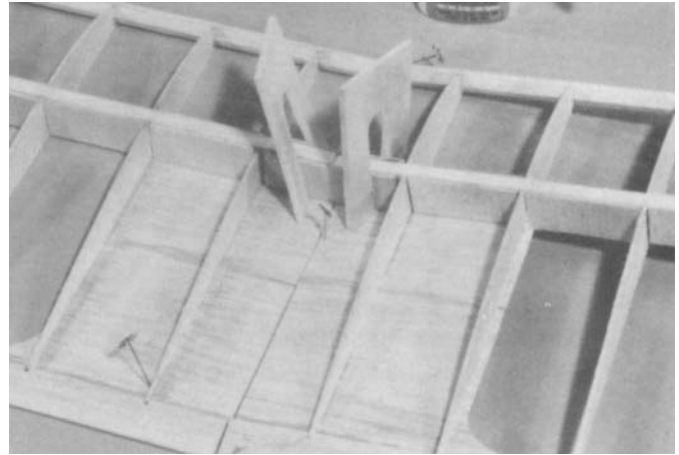
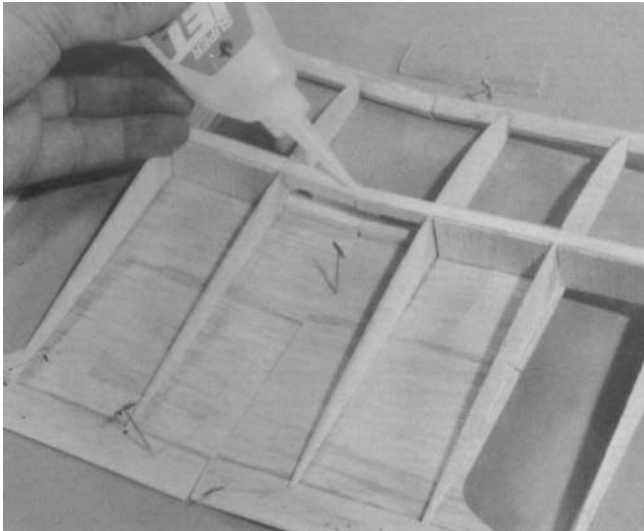

immediately reinstall clamps (from step 13) to hold both joiners tight on spars.

14. Be sure RIGHT WING is held firmly against LEFT WING and pin in place as shown. Remove joiners.
- Apply a liberal amount of SUPER JET to joints of L.E., spars, sheeting, and T.E.

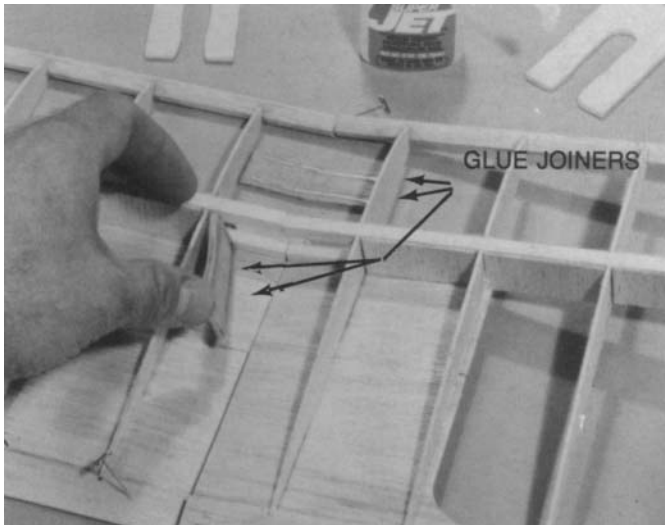

16. Position front half of rib No. 1 so one side aligns with center line of wing. Place rib wood scrap under rib No. 1. Adjust rib to align with spar center joints and L.E. joints. Glue in place.

15. Apply two heavy lines of SUPER JET to one side of both joiners, near the top and bottom. Position one end of joiner in place and swing the other end up against spars—hold momentarily. Repeat for other joiner—



- Glue No. 1 rib front half to first rib, making double thickness center rib at center joint.



Position half of rear rib No. 1 so one side aligns with T.E. center joint, and bottom sheeting joint. Glue in place. Glue back half of rib No. 1 to first, making double thickness rib.

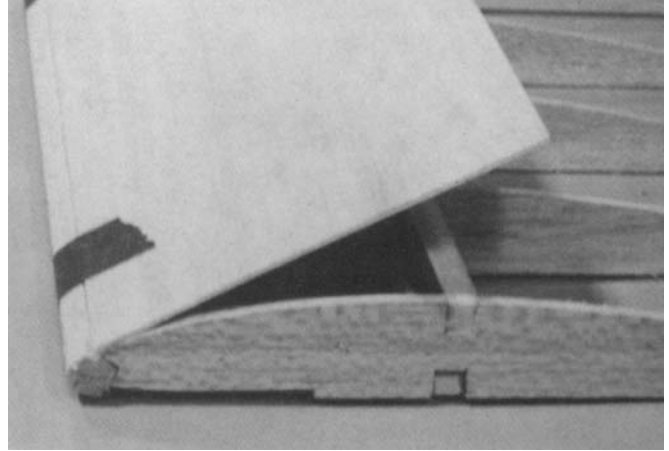

Wing tip end of sheeting can overhang end of wing, to be sanded flush with wing tip later.

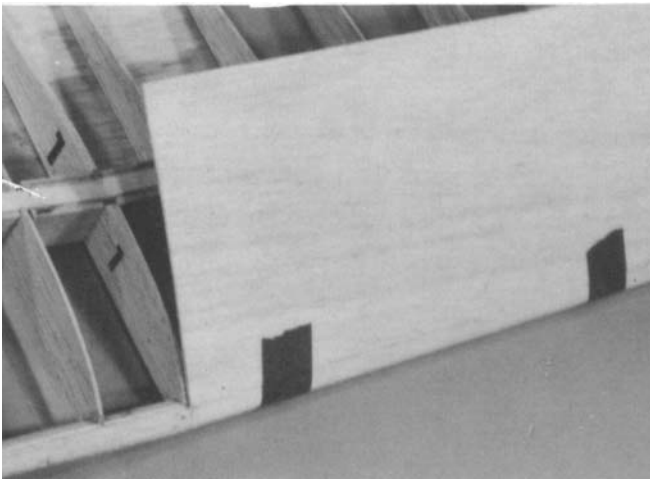

17a. Set top L.E. sheeting in place, matching inboard edge of sheet with joint between doubled ribs 1. Tape sheeting to L.E.

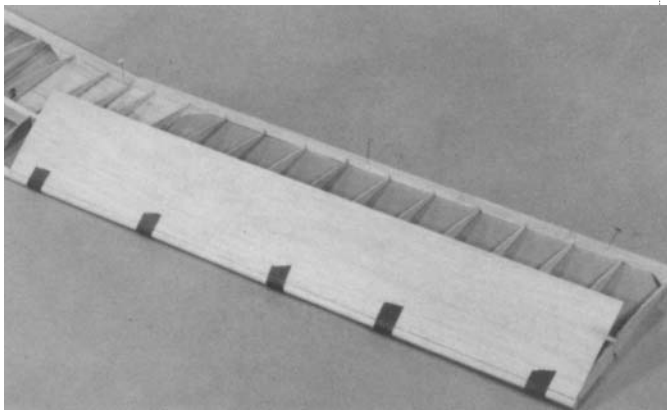
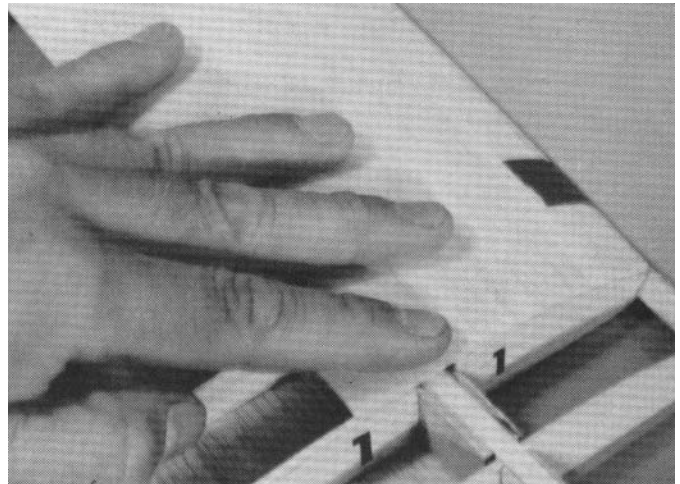

IMPORTANT!

WHEN SHEETING, KEEP WING PINNED FLAT.

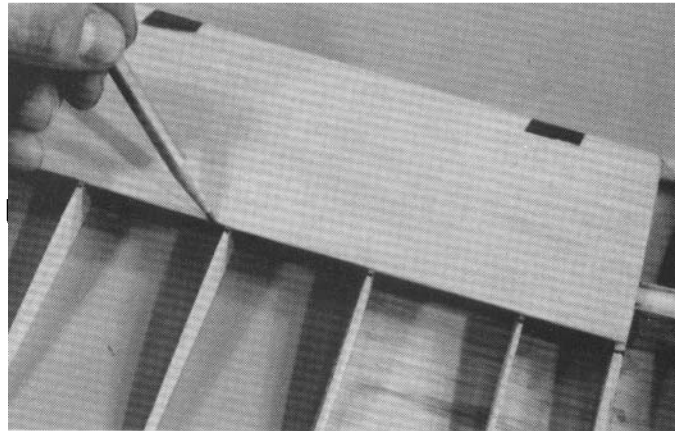

Press sheeting down on top of ribs and mark sheeting rear edge location on top of all ribs. This mark shows you how far back to apply glue for the sheeting.

Note: in this step you will be gluing the wing top sheeting in place—for maximum wing strength this sheeting must be glued to all wing structure it is in contact with. SLOW JET glue is recommended here since it gives you more time to carefully apply glue along each rib, spar, etc.

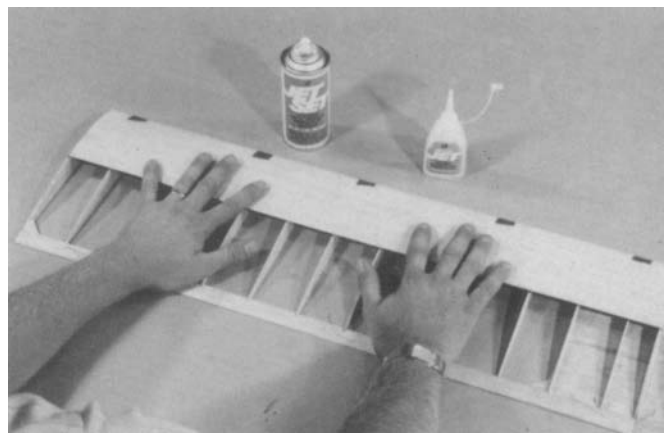
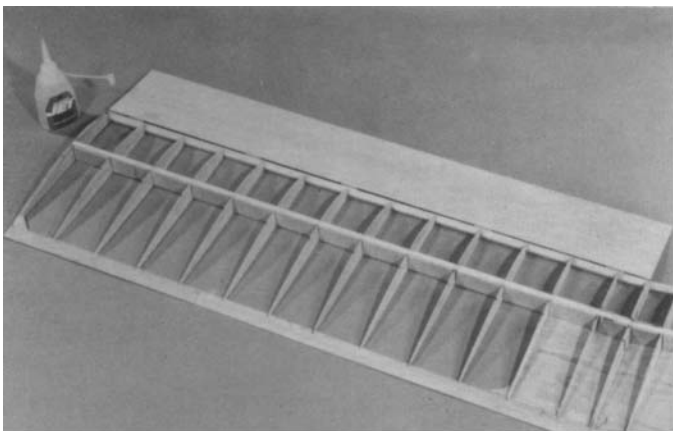

Press top sheeting down in contact with wing structure in a wiping motion to be sure all areas are glued until dry. If you are using epoxy or aliphatic resin, pin sheeting down until dry.

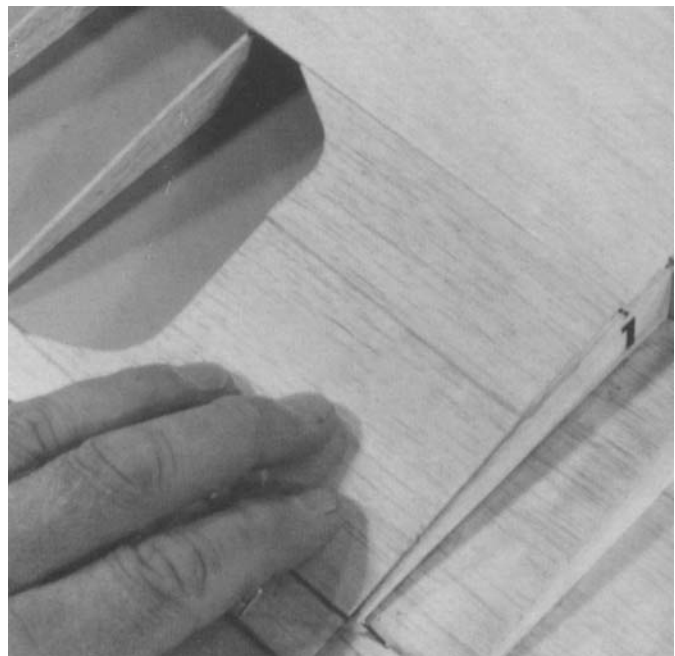
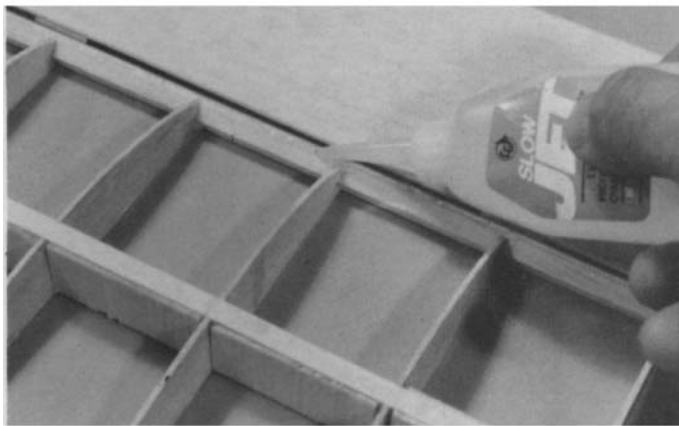

17b. Try top sheeting in place, trimming to fit as required. Match edge of sheeting with the center joint of doubled rib No. 1.



With the taped edge as a hinge, lift the sheeting. Apply glue along the entire top length of spar, L.E. channel, and every rib (apply glue to every surface to contact top sheeting). Proceed immediately to next step.

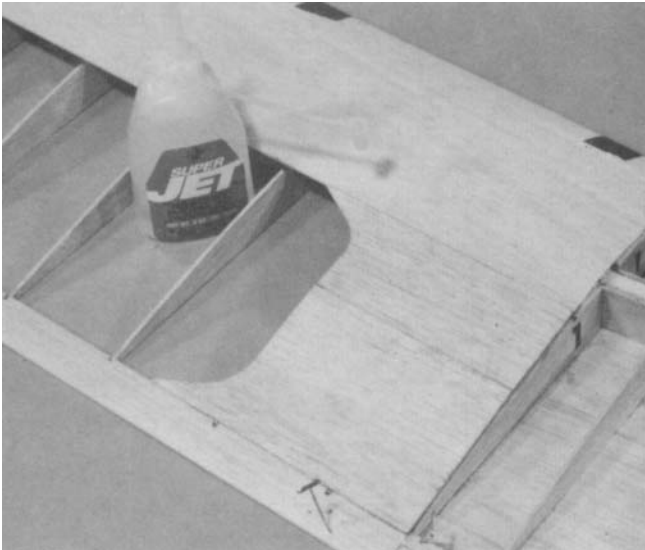

Glue top sheeting in place.

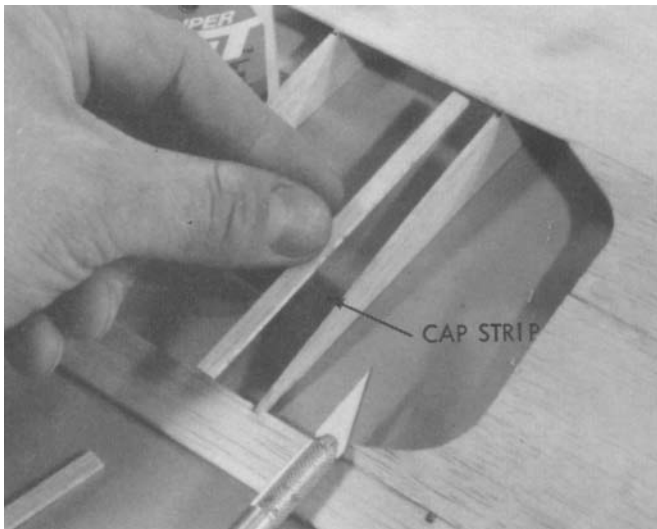
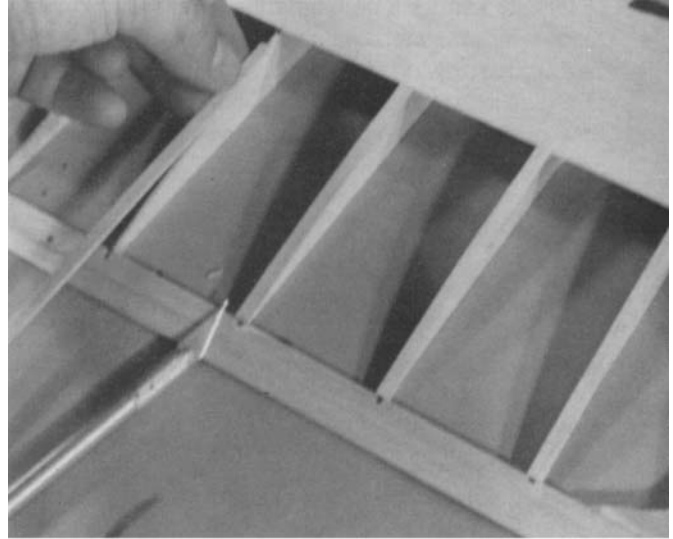

18. From 1/16" x 3/16" strips of balsa, cut cap strips to cover the exposed top edges of all ribs. Glue cap strips so they are centered over each rib.

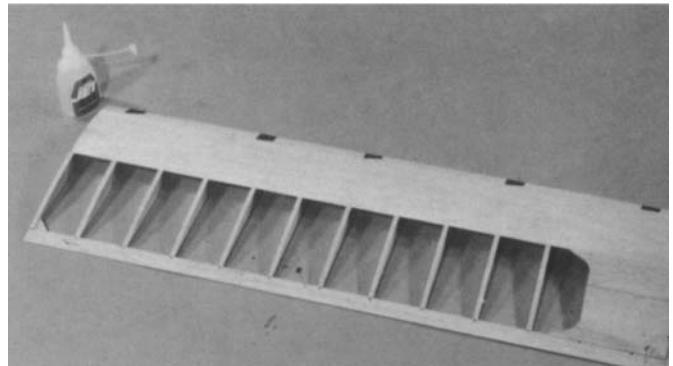

18. Continued

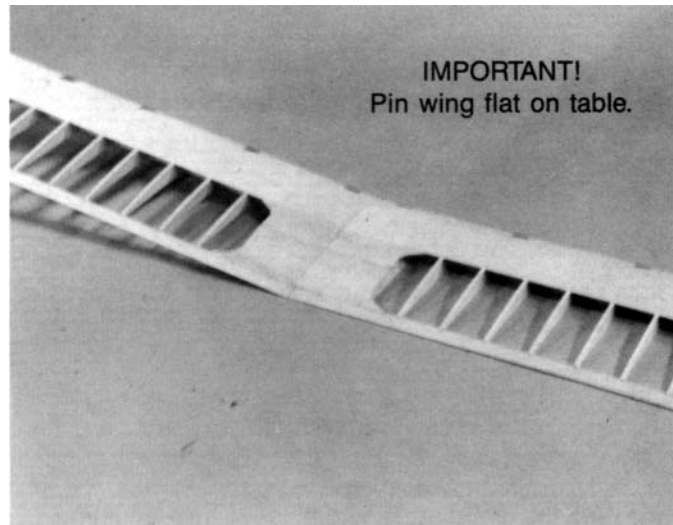

19. Remove all pins and gauges and repeat steps 17 and 18 and complete sheeting of the right wing.

THE BOTTOM L.E. SHEETING IS CUT SLIGHTLY UNDERSIZED

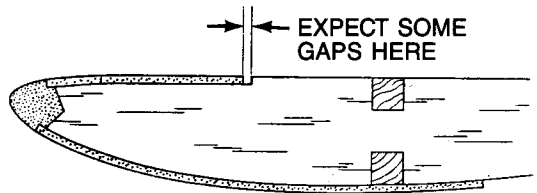

20.a The bottom sheeting has been cut slightly undersized so it will fit between L.E. and rib without trimming. There will probably be small gaps between sheeting and ribs as shown in sketch.

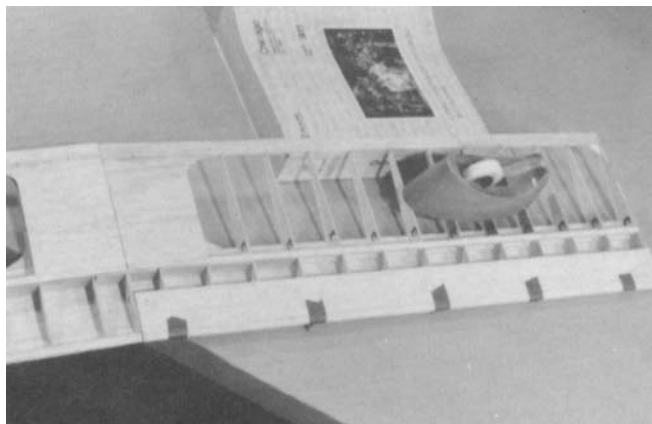

20c. Install bottom L.E. sheeting following same procedure as in step 17 and 19.

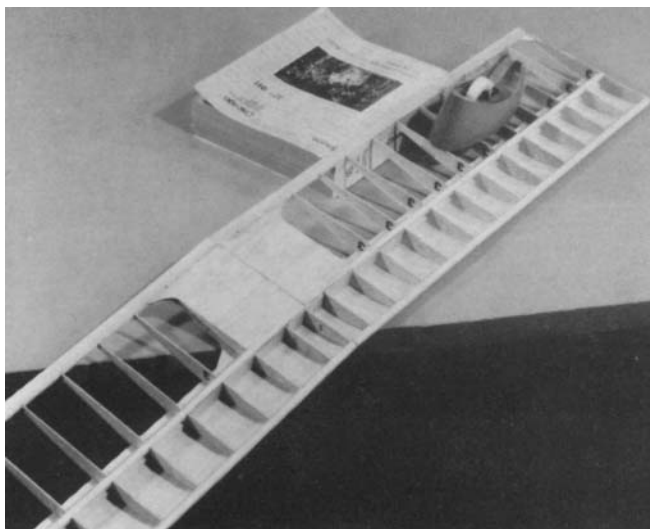

20b. Turn wing bottom side up. Position wing so one panel lies on your work table. Raise T.E. about 2" and support it so L.E. top sheeting lies flat on your work surface. Carefully place weight on wing bottom to hold wing in place. Phone book or similar works fine.

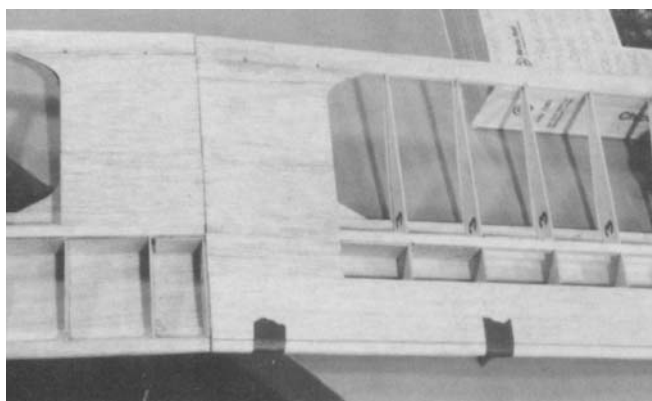

Install bottom sheeting in between L.E. and spar.



Install remaining bottom sheeting on other wing panel.

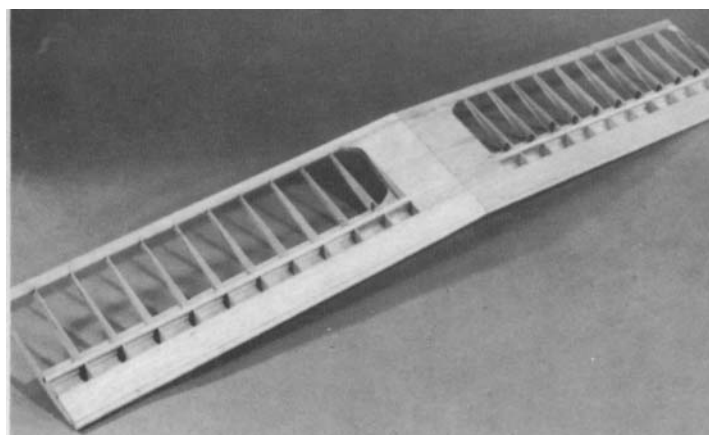

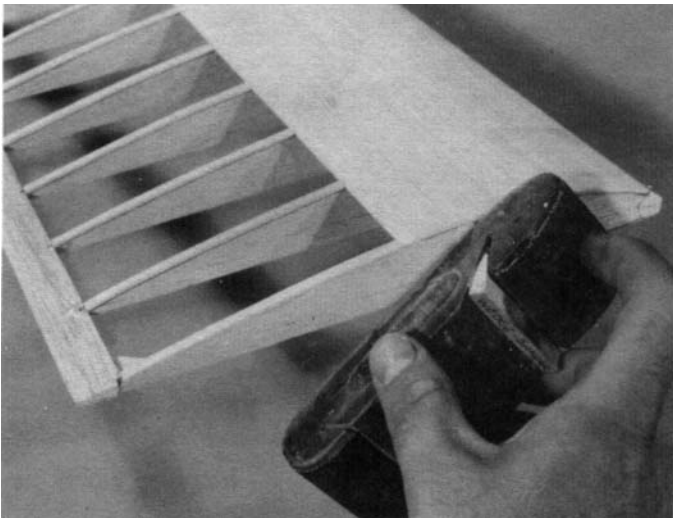

21. Carefully cut off and sand excess sheeting and spar material extending beyond the tip ribs.

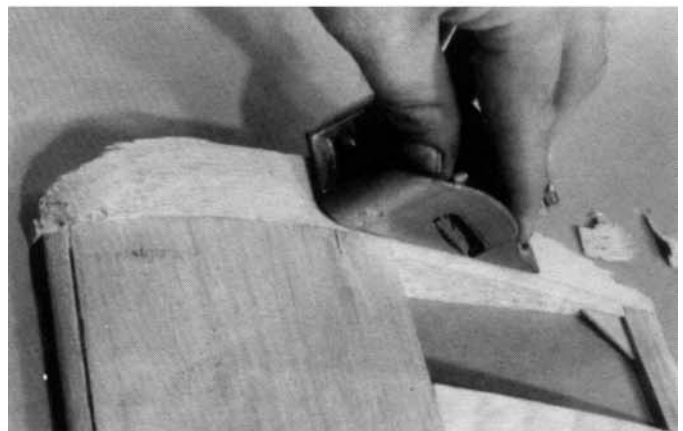
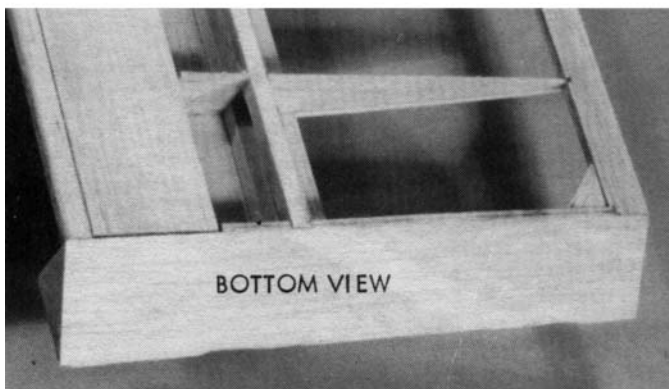
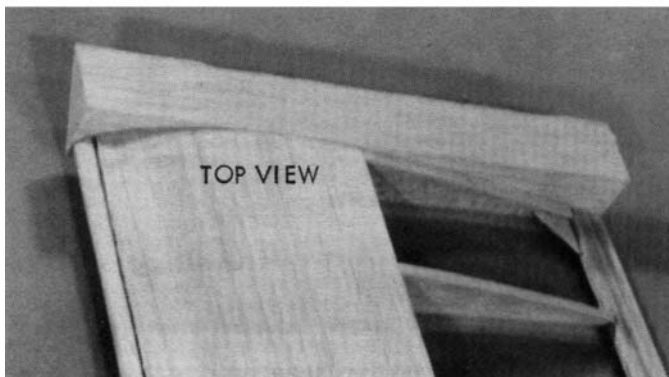
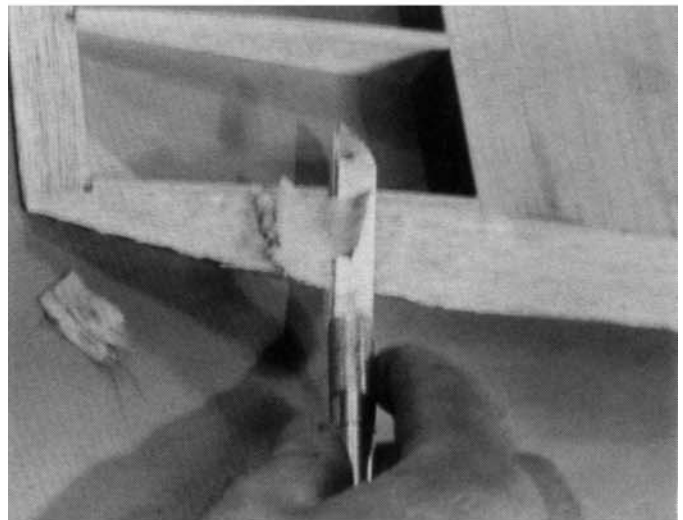
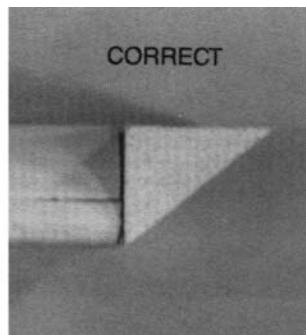
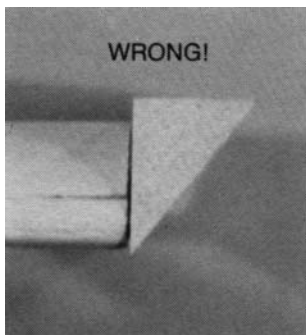
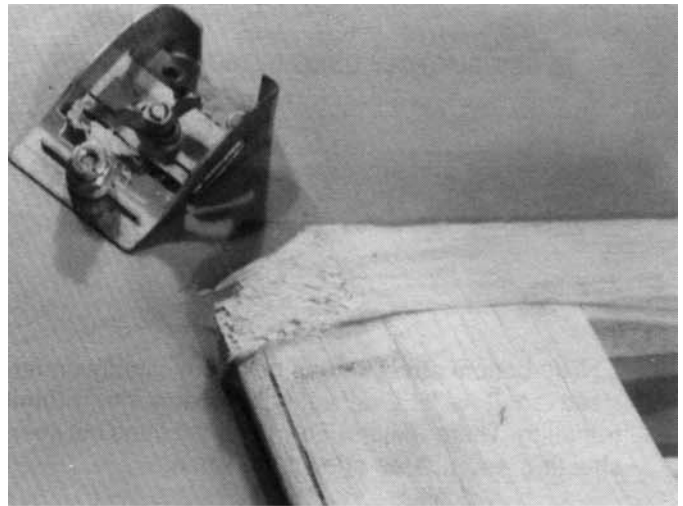

Working slowly, carve the top of the tri-strip until it almost matches the top contour of tip rib.

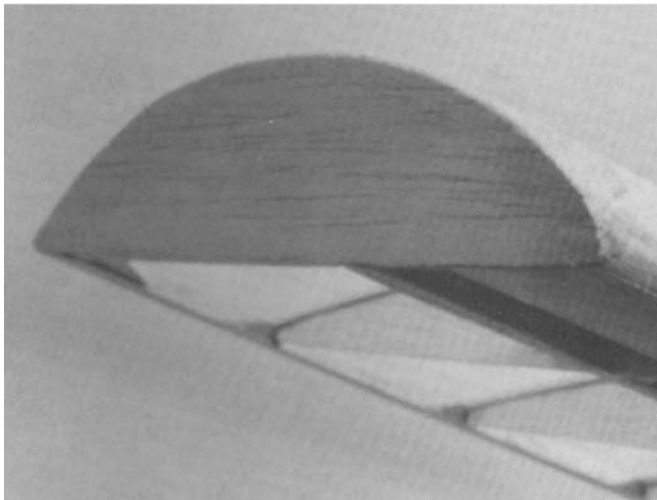
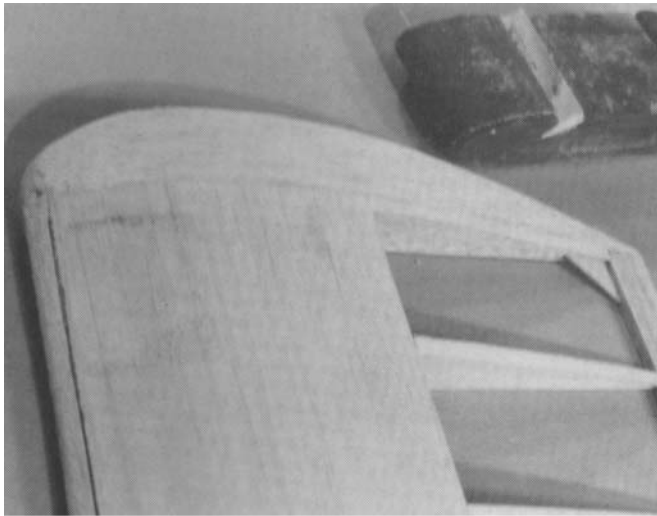

Sand to final shape with sandpaper block. Round all edges slightly.

Repeat for other wing tip.

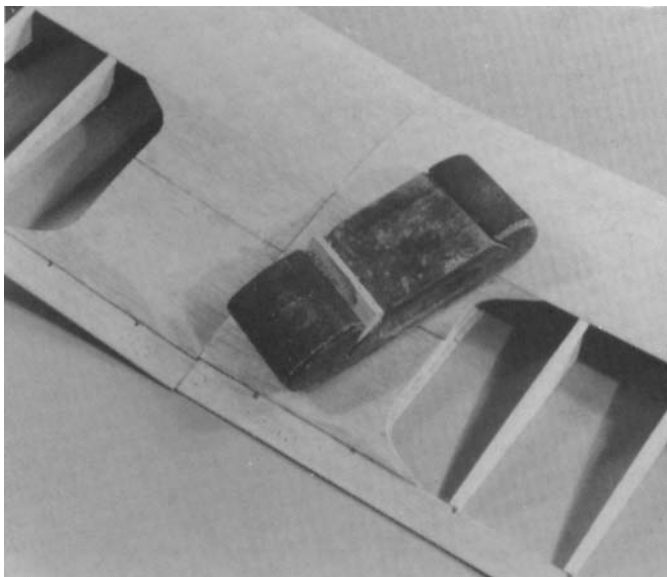

22. Using 240 grit (fine) sandpaper, flat sand entire wing to blend surfaces and remove high spots.

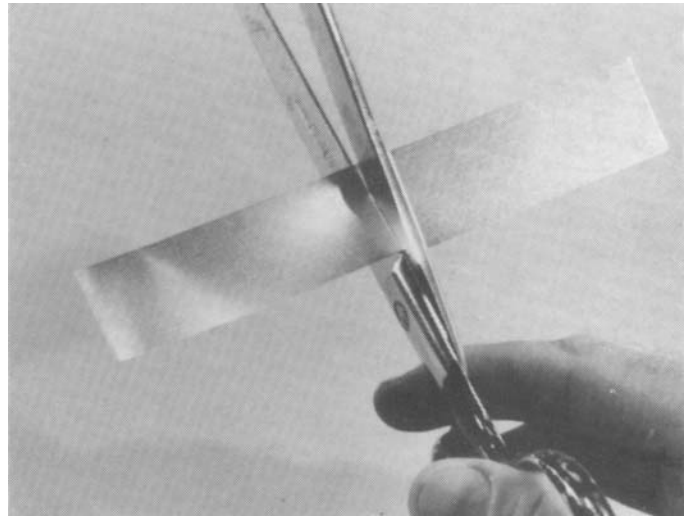

23. Cut 1" x 6" half-hard aluminum sheet into 3" pieces. Lightly sand aluminum surfaces for better gluing.

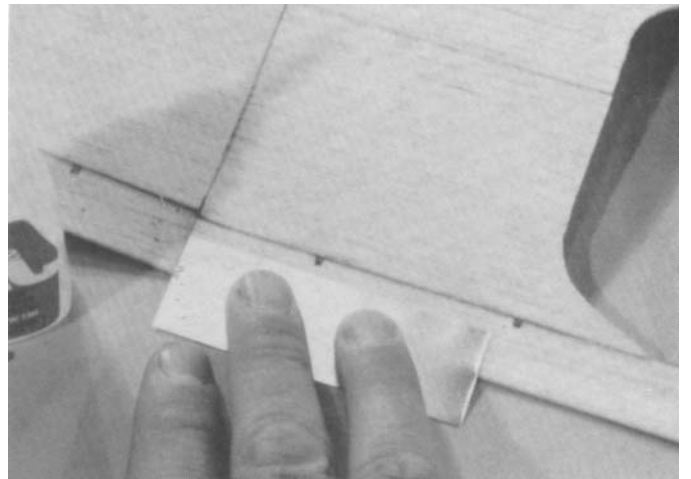

When dry, apply glue to other half and then wrap it around T.E.

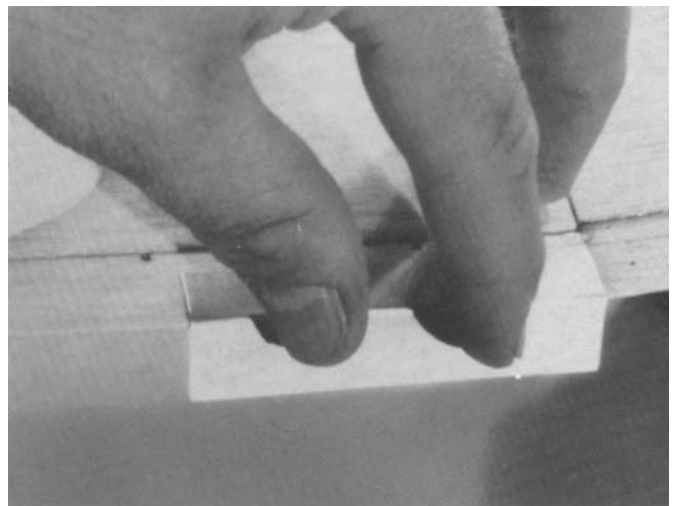

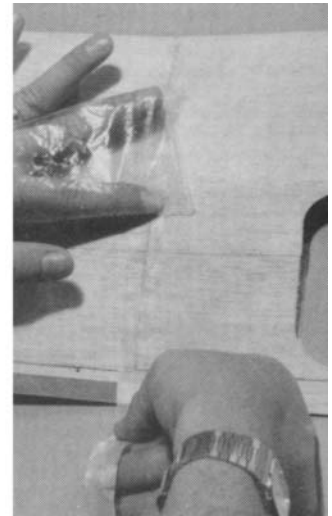
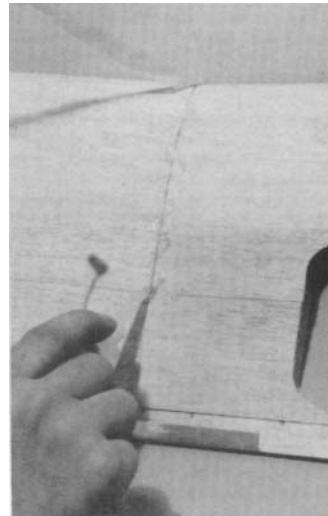
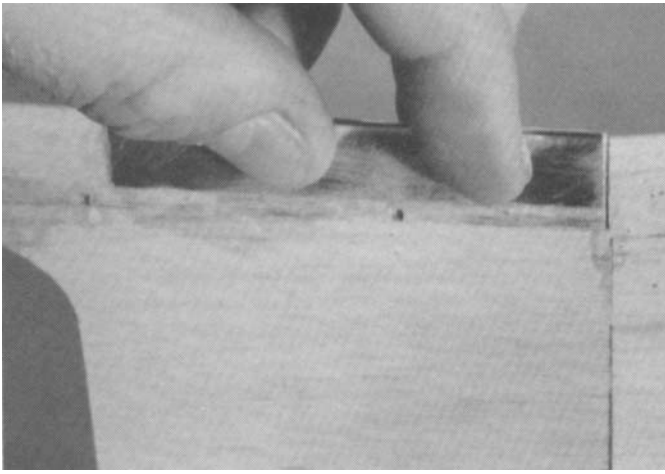

24. Apply some SUPER JET to half of a 3" aluminum sheet and glue it to wing T.E. as shown.

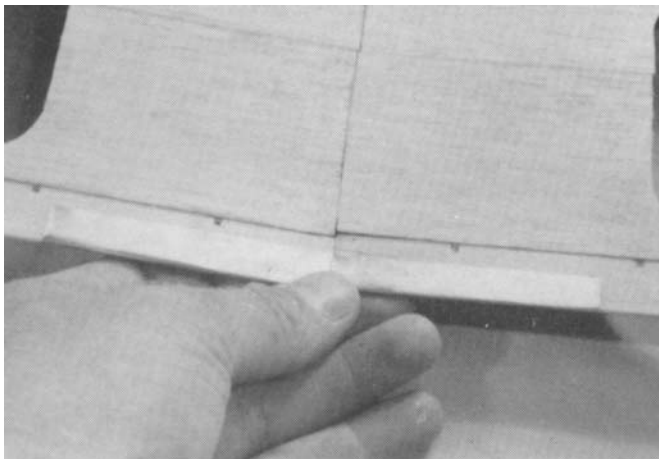

- Repeat for other 3" piece. This aluminum protects the trailing edges from the rubber bands.

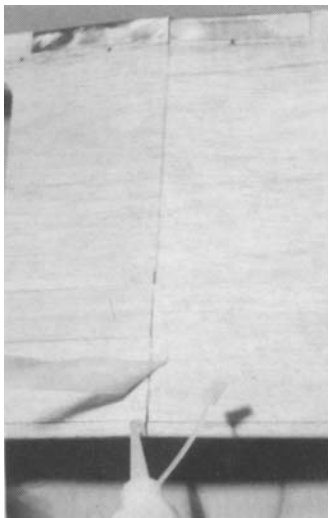
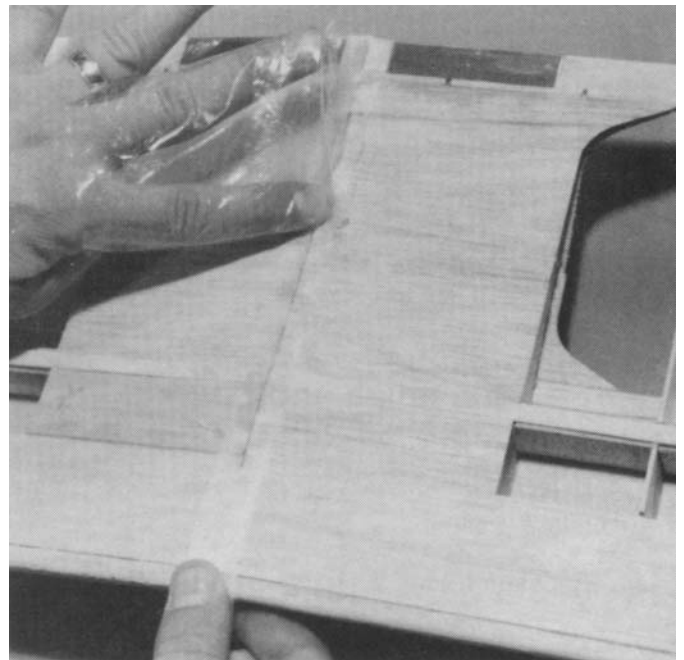

25. Apply a spot of SUPER JET on wing bottom and stick one end of 3/4" wide nylon to it. Let dry until the nylon is glued solidly to the balsa.
- Apply a squiggle of glue to wing and pull nylon fabric into it. Rub nylon into glue with your finger (cover finger with a plastic bag or similar).

- Repeat gluing procedure and apply nylon around L.E., across top of wing, around T.E. and finally overlapping where you started on wing bottom.

- After entire center joint has been wrapped with nylon, apply another coat of glue and force it down through the nylon. Let dry thoroughly.

THIS COMPLETES THE WING ASSEMBLY.

FUSELAGE ASSEMBLY

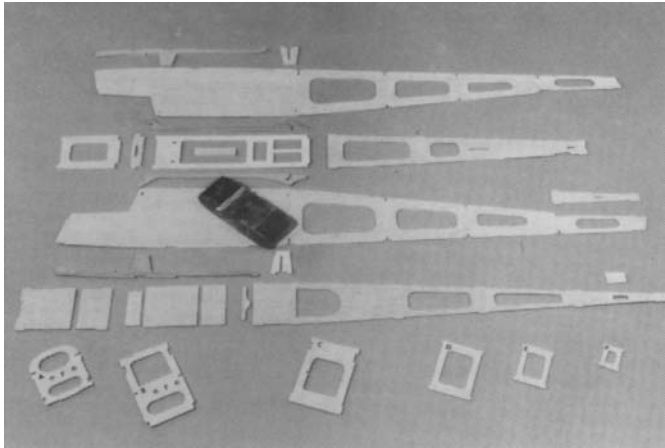

D/C SHEET 4203	Fuselage side	2 REQ'D
D/C SHEET 4204	Fuselage Formers	1 REQ'D
D/C SHEET 4205	Fuselage Top	1 REQ'D
D/C SHEET 4206	Fuselage Bottom	1 REQ'D
D/C SHEET 4208	Servo Tray	1 REQ'D
D/C SHEET 4209	Formers & Doubler	1 REQ'D
D/C SHEET 4210	Fuse Doubler & Joiner	2 REQ'D

1. Carefully remove all fuselage (fuse) parts from die-cut balsa and plywood sheets. Lightly sand any rough edges.

BEFORE GLUING THE FUSELAGE TOGETHER, THERE ARE A FEW "SUB-ASSEMBLIES" TO MAKE.

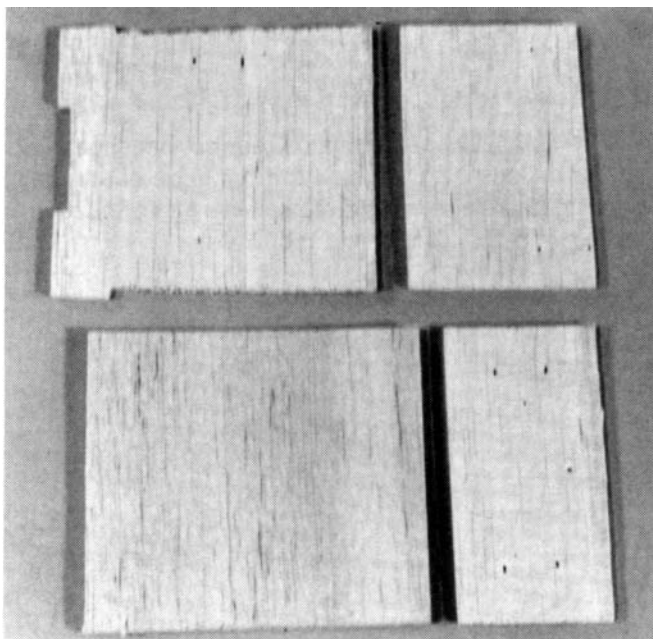

2. Position the die-cut balsa parts for the forward bottom sheeting and the hatch as shown in the photo. **IMPORTANT!** Be sure to position parts as shown—they have similar shapes but are different sizes.

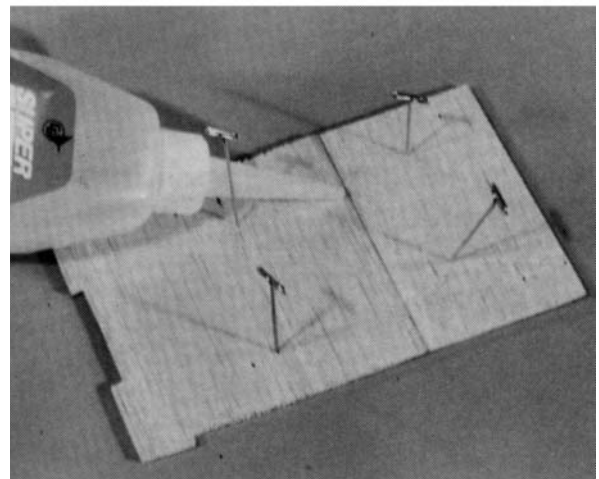
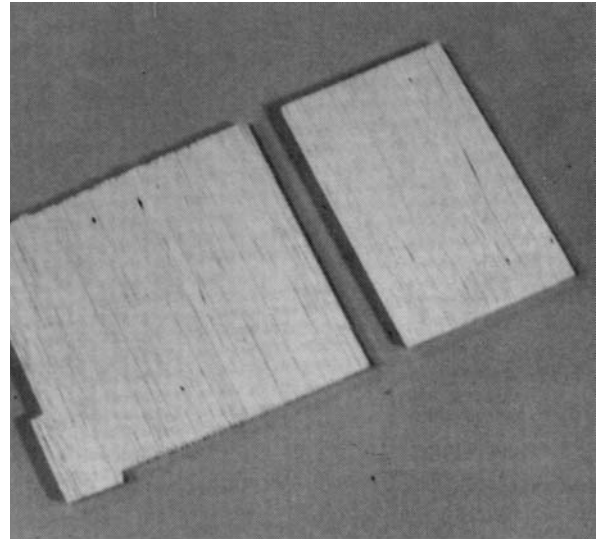

3. Glue the two front bottom sheeting pieces together as shown.

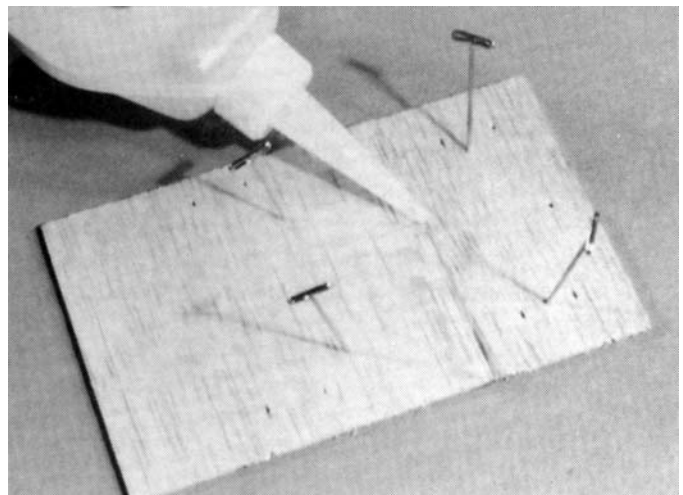

4. HATCH ASSEMBLY

- Glue two balsa hatch pieces together as shown.

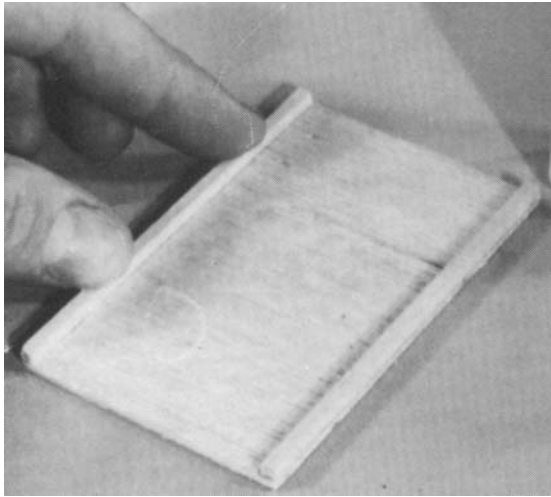

□ Measure and cut 1/8" square x 8" balsa stick into two 4" long hatch rails. Flush one rail with hatch edge and ends. Glue rail to hatch. Glue remaining rail to other side of hatch.

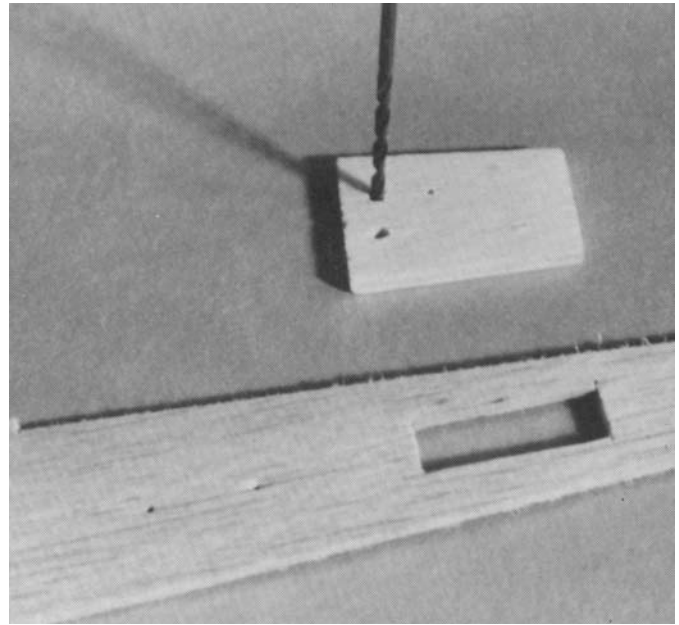

5a. REAR BOTTOM SHEETING

□ At punchmark locations, drill two 1/16" diameter holes through 1/8" ply tail wheel mount.

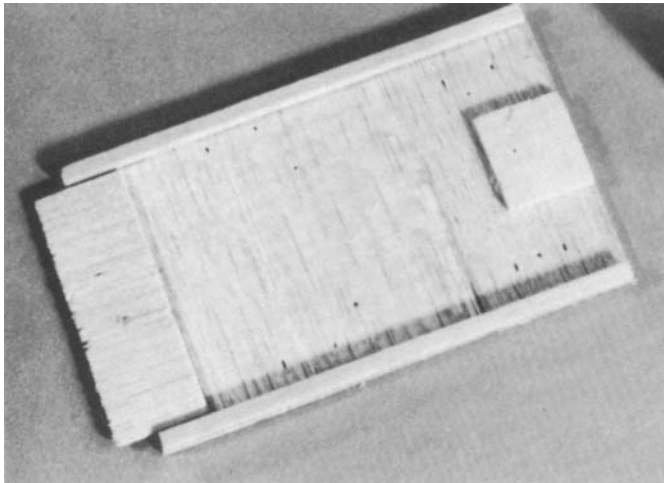

□ Position the 1/16" balsa tongue so about 1/4" extends out from the hatch end as shown. Center it between the rails and glue to hatch.

□ At the other hatch end, flush 1/8" ply screw reinforcement. Center it between rails and glue in place.

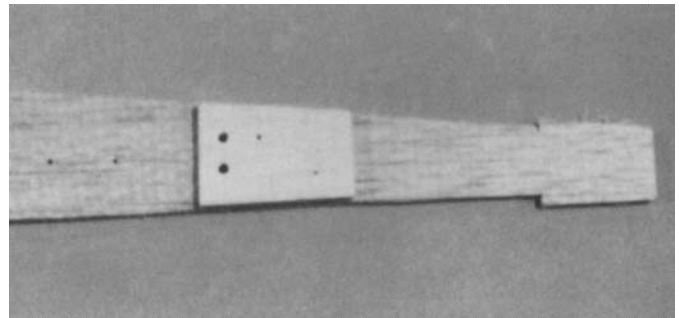

□ Position tail wheel mount on rear bottom sheeting so the drilled holes are next to front edge of square opening (there also is a die-marked line in the sheeting for locating the front of the mount).

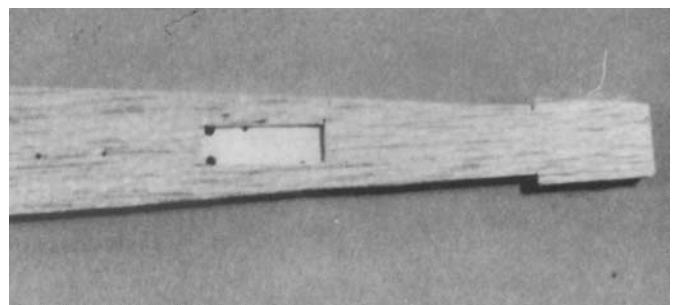

□ Glue the tail wheel mount in place.

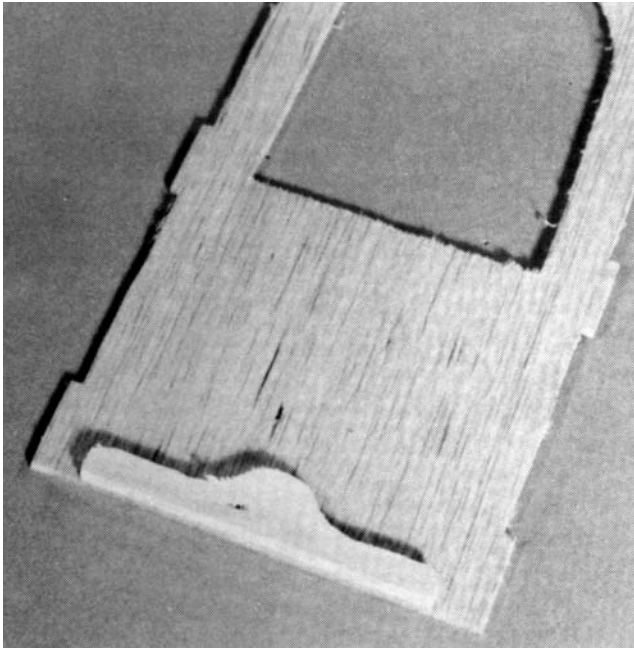

- 5b. Position the 1/8" ply screw reinforcing strip on the **same side** of the bottom sheeting as the tail wheel mount. Flush and center it along front edge of sheeting as shown. Glue in place.

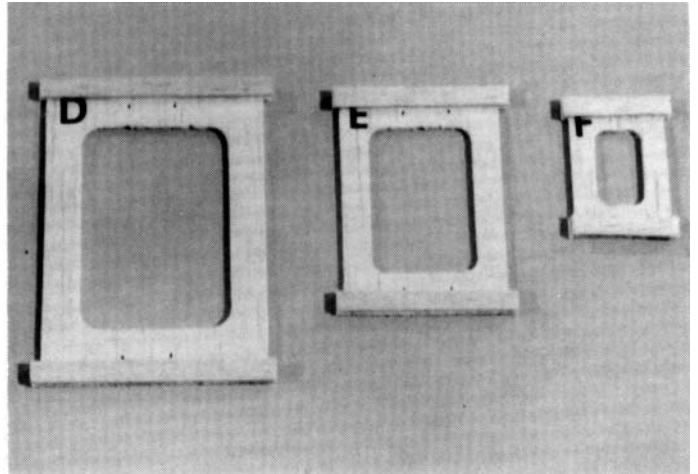
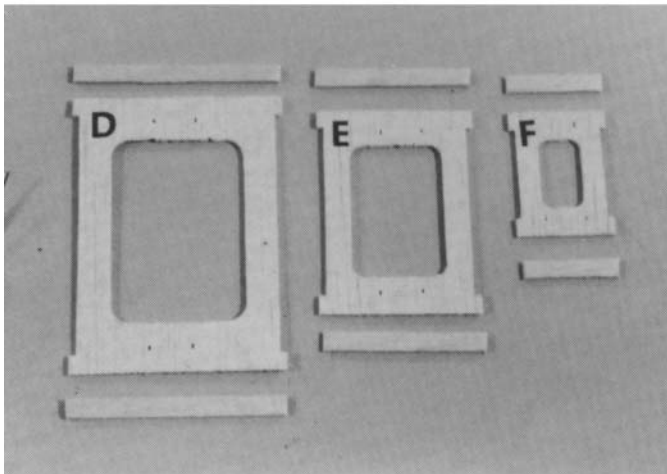
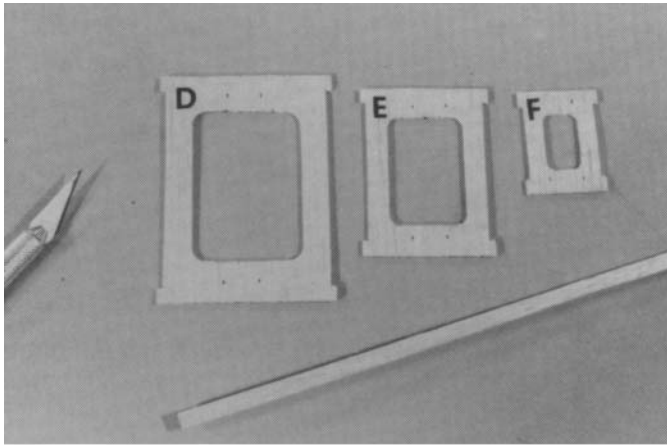

6. From 1/16" x 3/16" truss material, cut and glue strips to match top and bottom of Formers "D," "E," and "F" as shown.

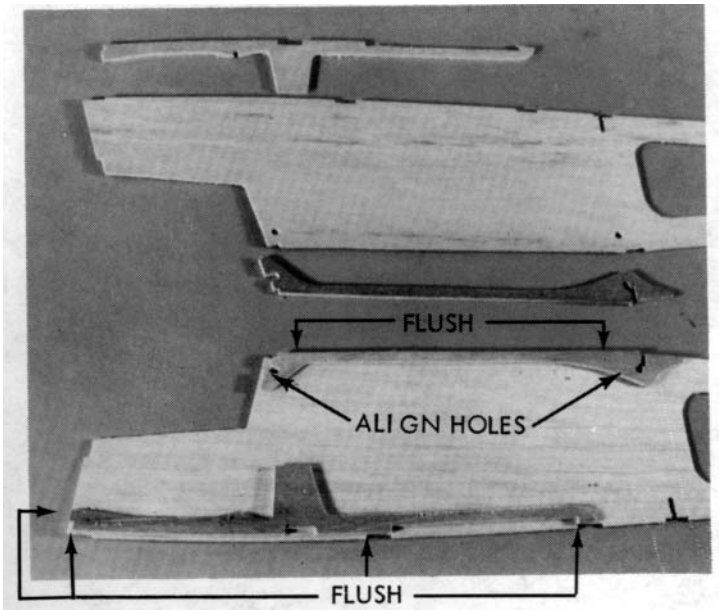

7. Be sure sides are laid down left and right as shown.
- USING NO GLUE, temporarily position cabin top and bottom doublers on fuse sides. Check fit and placement of parts before gluing. Glue top doublers to body sides, making sure to flush parts as shown. Glue bottom doublers to body sides, making sure to flush parts as shown.

CONTINUED AT TOP OF NEXT PAGE

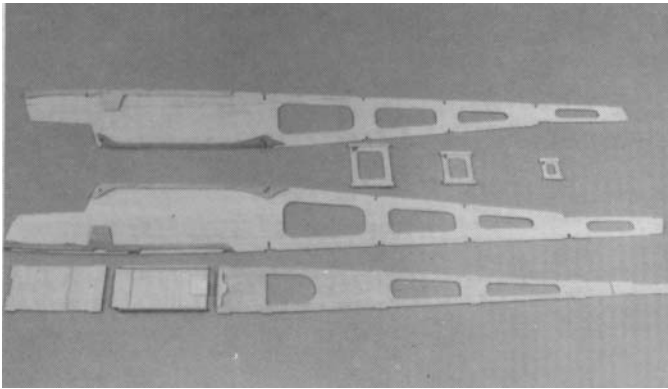

ALL SUB-ASSEMBLIES FINISHED, READY FOR FUSELAGE ASSEMBLY.

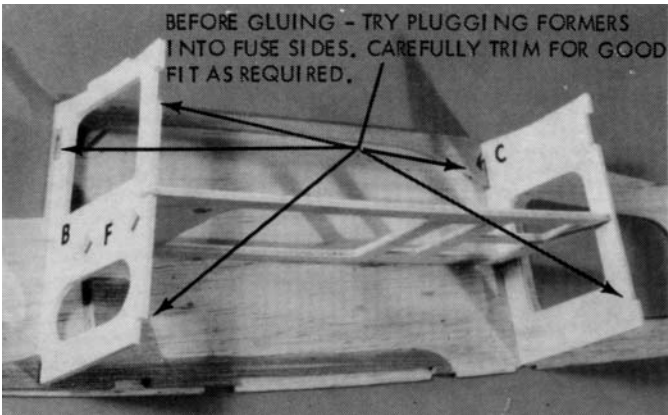

8. Pin right fuse side down on table as shown.
 - Plug Former "C" into holes in body sides.
 - Slide servo tray into position, engaging tray tabs into former slots.
 - IMPORTANT!** With side stamped "B" facing forward, plug Former "B" into fuse side holes and engage with servo tray tabs.
9. Glue these parts together.

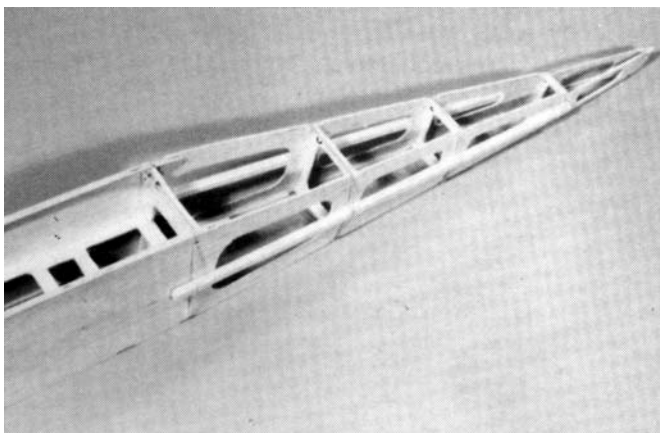

10. Position left fuse side on Formers "B" and "C," plugging formers into holes in fuse side. Carefully remove pins from right fuse side. Hold parts together with a rubber band (**do not use** rubber bands that are **too tight** or they may **crush** the balsa).

Tape fuse rear ends together.

11. Spread fuse sides apart slightly and plug Former "D" into holes in body sides (balsa strips facing forward). Hold with a rubber band.

Install remaining Formers "E" and "F" in same manner, using rubber bands to hold parts.

Slide one 1/4" square x 16" balsa pushrod under rubber band at Former "C" and slide it back under other rubber bands to Former "E" location. Center it on the fuse side as shown so it pushes the sides tight against the formers. Slide other pushrod under rubber bands on opposite side .

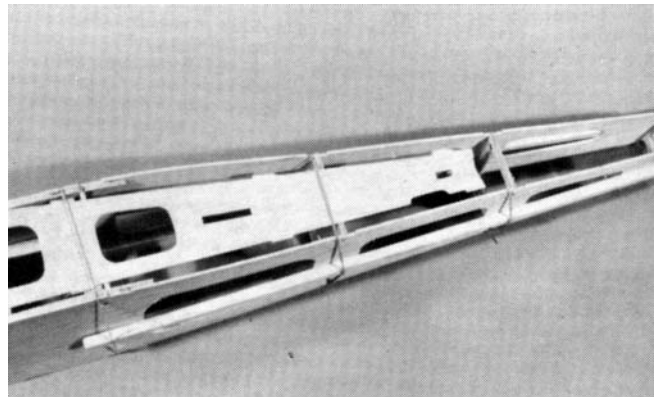

12. Insert top sheeting under rubber band at Former "C," and work it towards tail, slipping it under bands as you go.

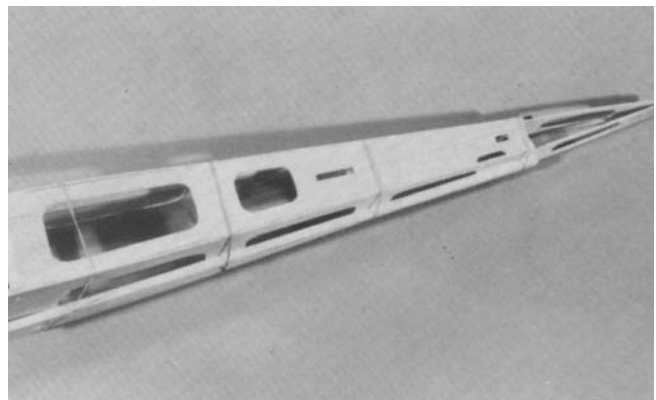

Lock tabs at both ends of top sheet into corresponding notches in fuse sides.

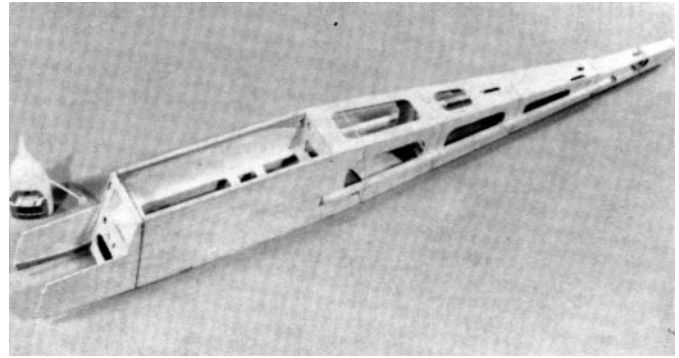
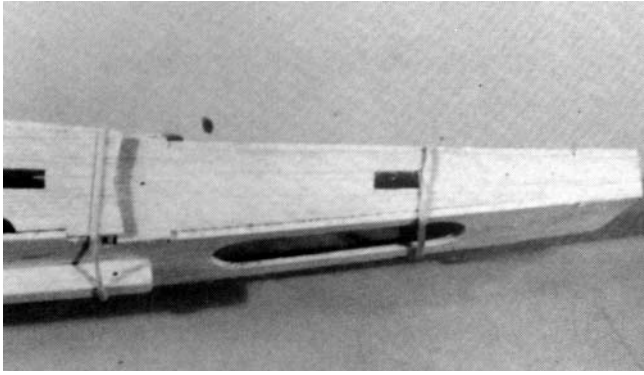

14. Place fuse over TOP VIEW on plan sheet, viewing from above, carefully align the fuse to match plan outline. If an area of the fuse is off, adjust that portion in the direction required.

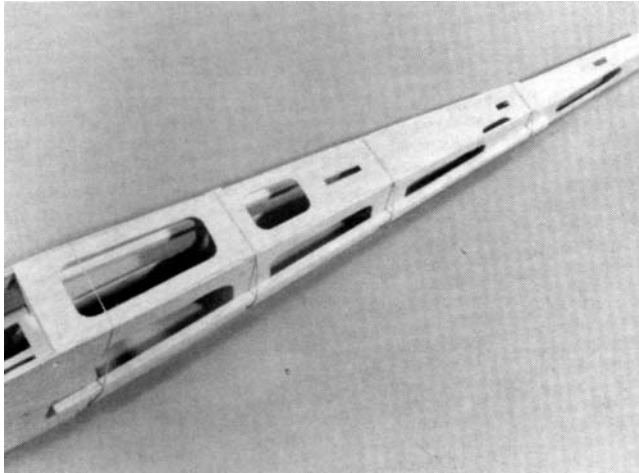

- Position stab platform between fuse ends, and hold together loosely with a rubber band.

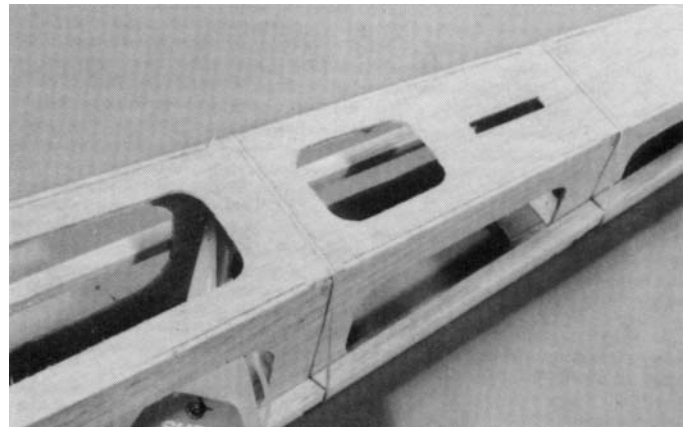

- When satisfied with alignment, permanently glue sides, formers, and sheet parts in place (DO NOT GLUE the PUSHRODS—they are used here TEMPORARILY and must be removed). Apply a bead of Super Jet along all joints inside and outside, or from both sides in the case of formers—it will penetrate the joint and leave a slight reinforcing fillet.

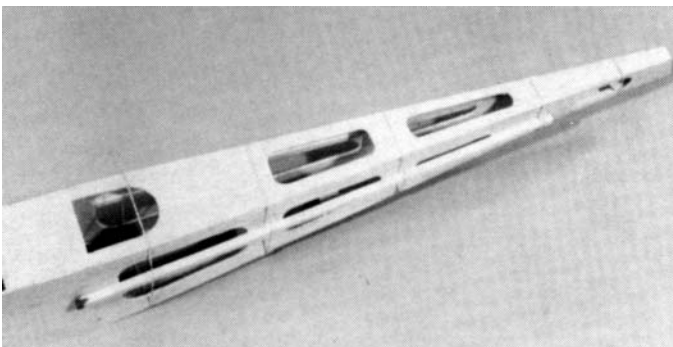
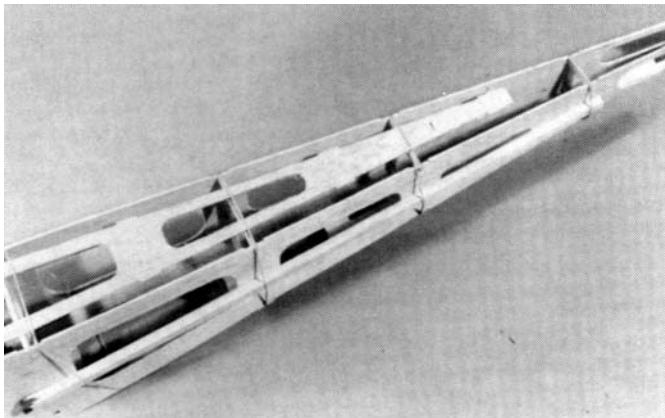

13. Position rear bottom sheeting in same manner.

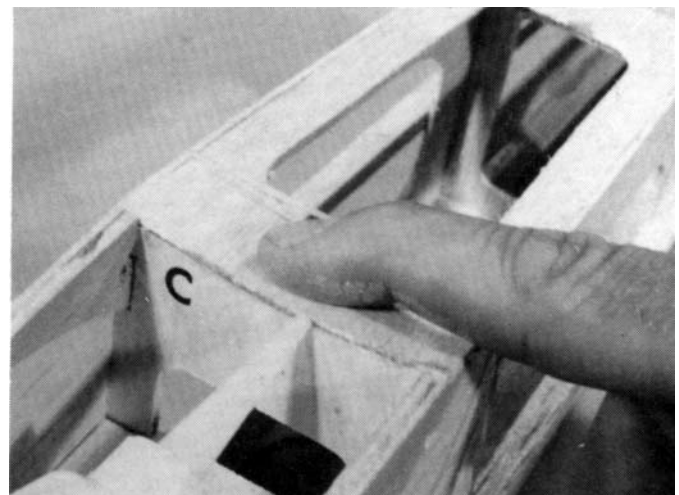

- Glue top sheeting down to match angle in top of Former "C."

LANDING GEAR (L.G.) AND BATTERY BRACES

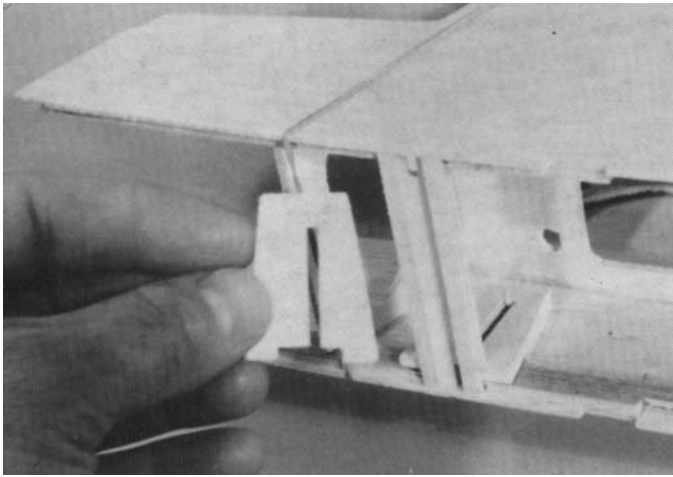

ALIGN LANDING GEAR BRACE SLOT WITH SLOT IN LANDING GEAR BLOCK.

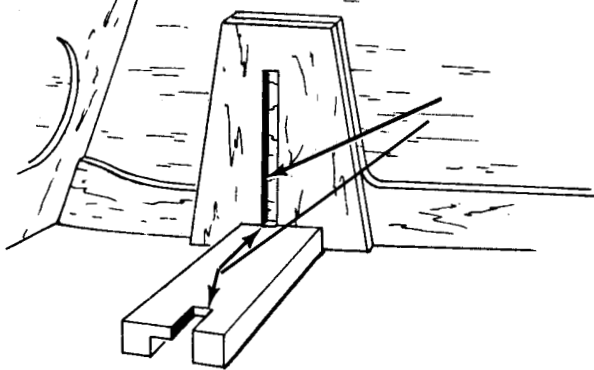

VIEW LOOKING AT RIGHT FUSE SIDE WITH LEFT FUSE SIDE REMOVED

15a. □ With groove facing out from bottom of model, glue L.G. block in place. Match landing gear brace slots with notches in L.G. block and glue braces to sides.



THE LEFT FUSE SIDE HAS BEEN REMOVED TO SHOW INTERIOR DETAILS

15b. □ Position battery brace as follows: match rear notches with L.G. braces and flush front edge with lower opening in Former "B." Glue brace to former and sides.

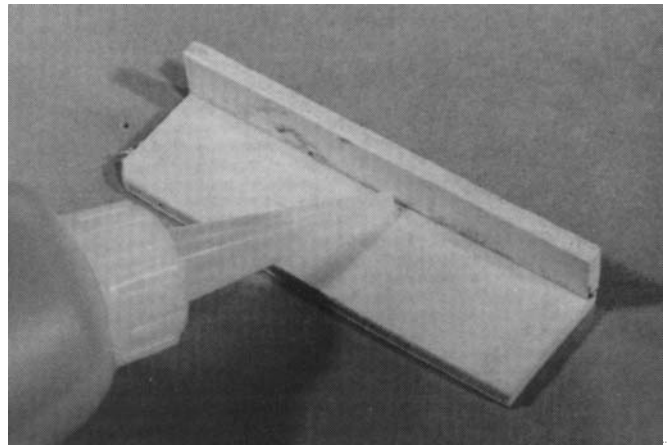

15c. □ Glue narrow strip to rear battery brace.

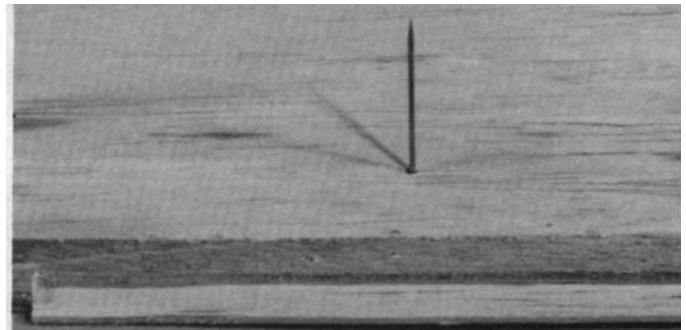

□ To locate battery brace, insert two pins into the fuse sides at die-marked locations. See plan for details and locations.

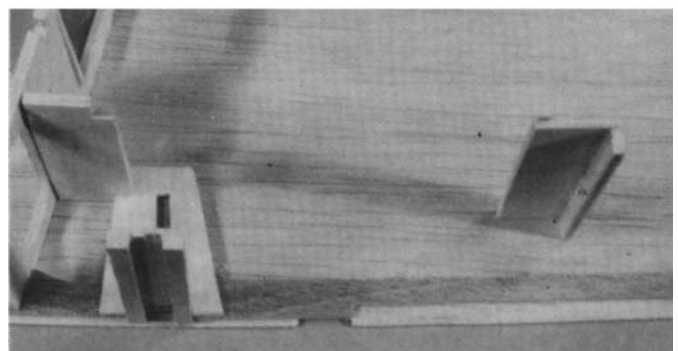
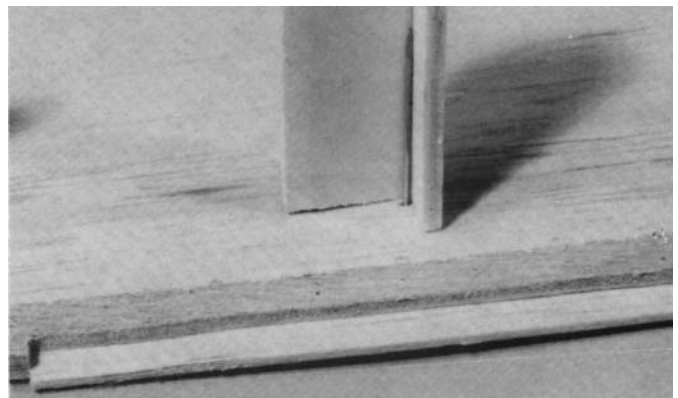

□ Locate rear battery brace inside the fuse on the pins as shown on the plan side view. Glue in place. Remove the pins.

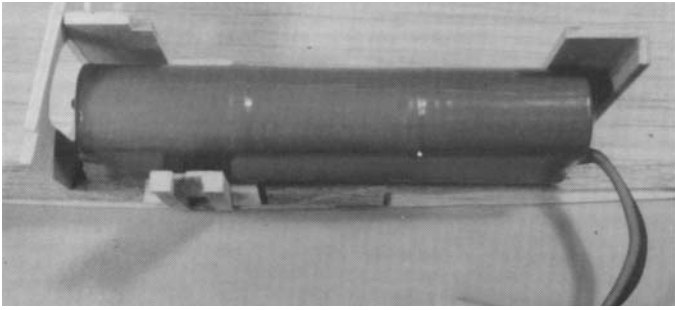

BATTERY TEMPORARILY INSTALLED TO SHOW HOW BRACES HOLD IT

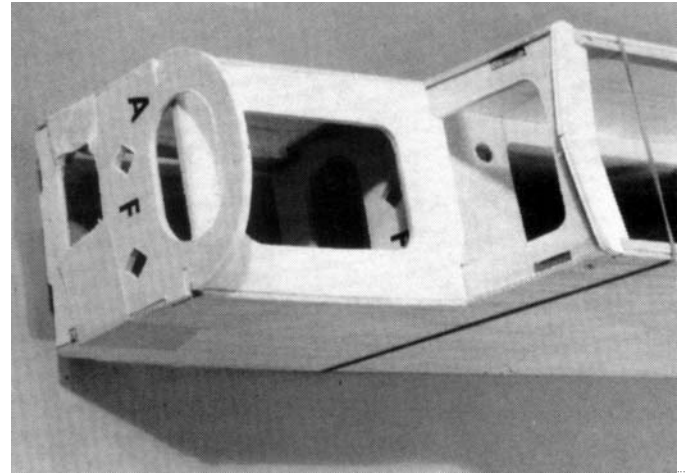

18. Tilt front of top sheeting down to engage tabs with Former "A" slots. Then rotate sheeting rear edge down into Former "B." Glue sheeting to formers and sides.
19. Place windshield top doubler in position to match angle in top of Former "B." Also, doubler should tilt backwards slightly as shown in plan side view. Glue it in place.

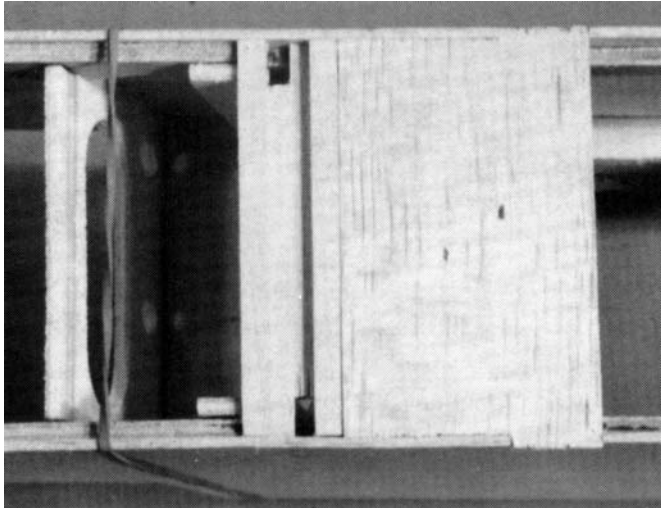

16. Match bottom sheeting tabs with fuse sides and glue center bottom sheeting in place.

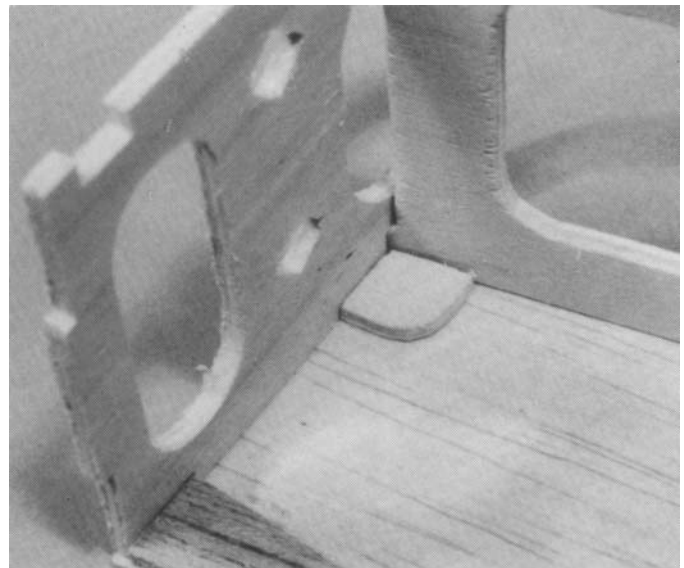

20. Glue two small screw reinforcement tabs to fuse sides at upper corners where Former "A" meets top sheet.

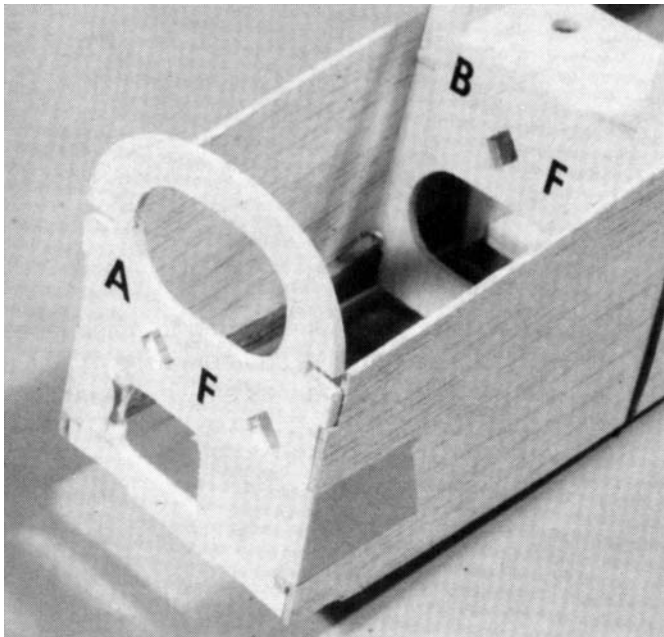

17. Glue Former "A" to fuse fronts, hold with tape as necessary. (IMPORTANT! The "A" stamped on the former faces forward.)



21. Measure and mark 1/4" square x 6-3/4" motor bearers 3-1/8" from an end.

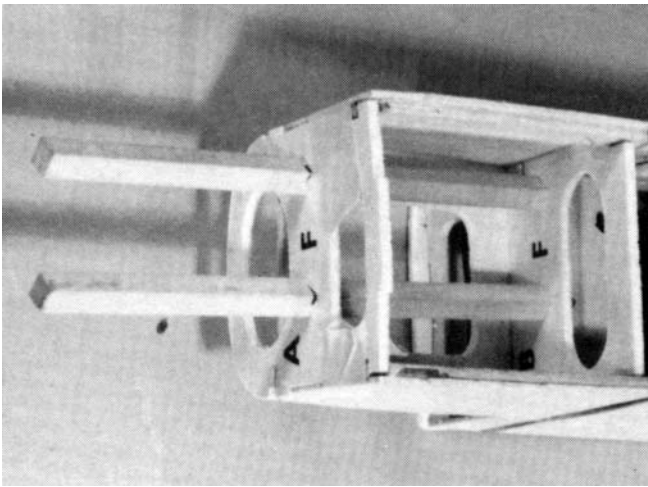

- Slide motor bearers through diamond shaped holes in Former "A" to "B" so that the 3-1/8" length protrudes out the front Former "A."
- Glue motor bearers firmly to Formers "A" and "B." (Refer to plan for placement.)

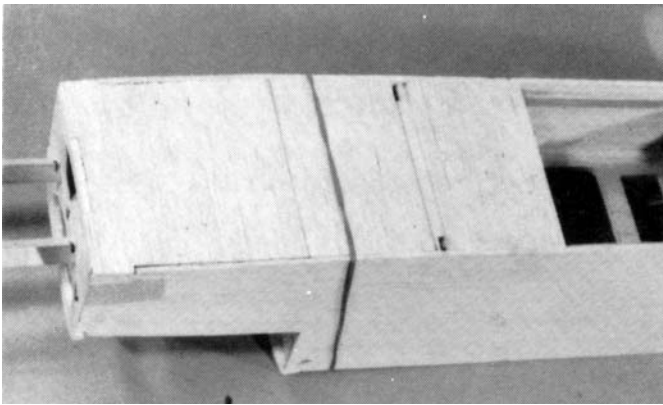

22. Install front bottom sheeting, matching sheeting tabs with notches in Former "A." Glue to formers and sides.

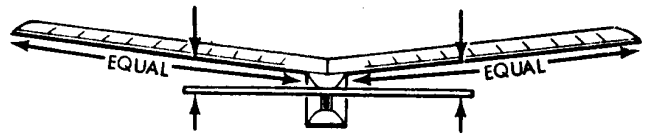

LEVEL STAB WITH RESPECT TO WING

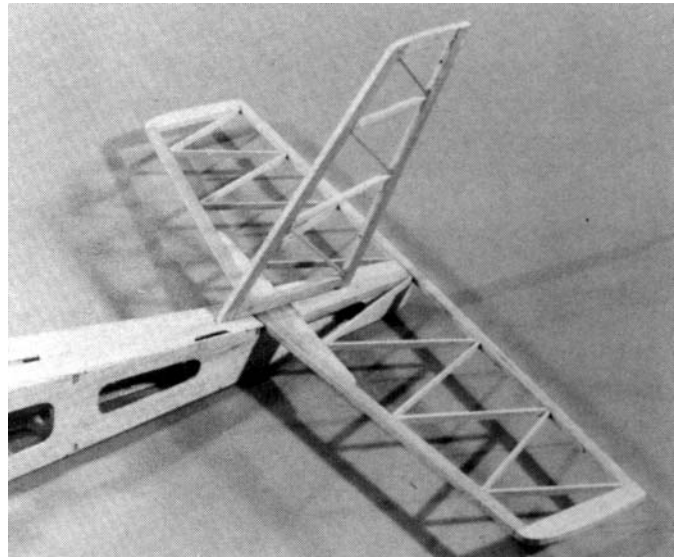

- Sand stab platform area as may be necessary to provide a good level fit for stab.

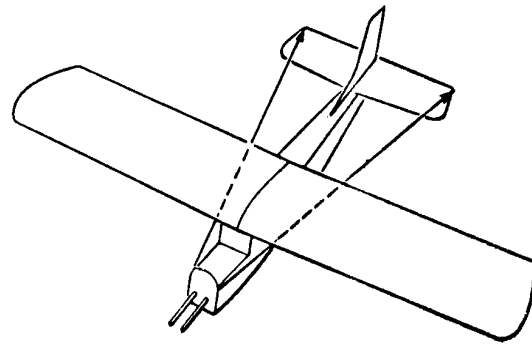

- Center stab on fuse, measuring to obtain equal distance from side to side, and from nose of fuse to rear corner of each stab tip as shown. Pin in place.

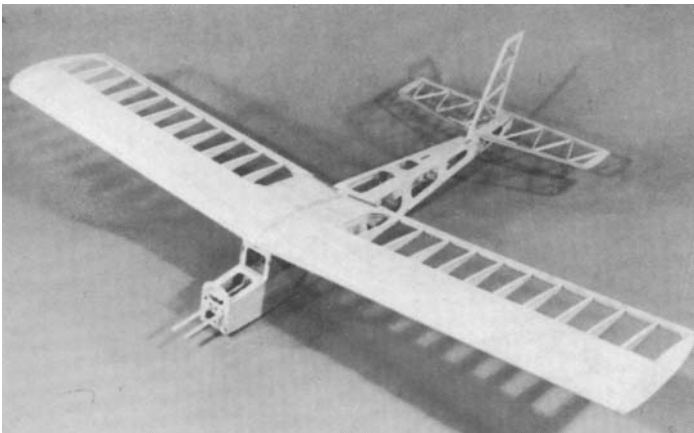

23. Temporarily install wing hold-down dowels in fuse. Rubber band wing in place on fuse, making sure it is centered. Viewing model from rear, see if stab sets level with respect to wing.

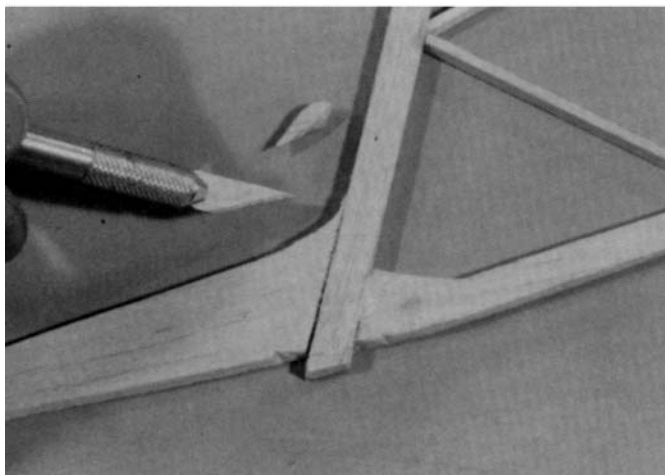
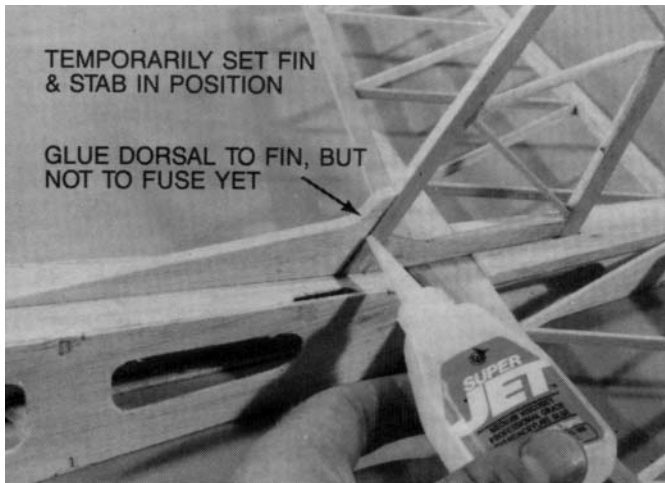

24. Trial fit fin in place. Glue dorsal fin to main fin but not to fuse, as shown. When dry, watch grain and very carefully trim off die-cut bump. Finish sanding.

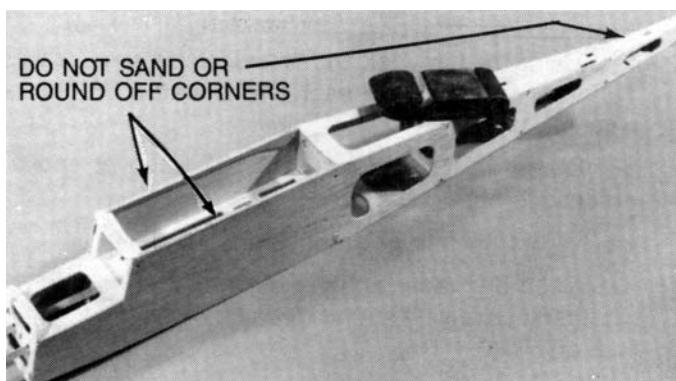

25. Omitting the top cabin area and the top of the tail mounting area, flat sand the fuse and round off corners,. DO NOT SAND the cabin and tail areas, EXCEPT VERY LIGHTLY TO REMOVE BURRS!

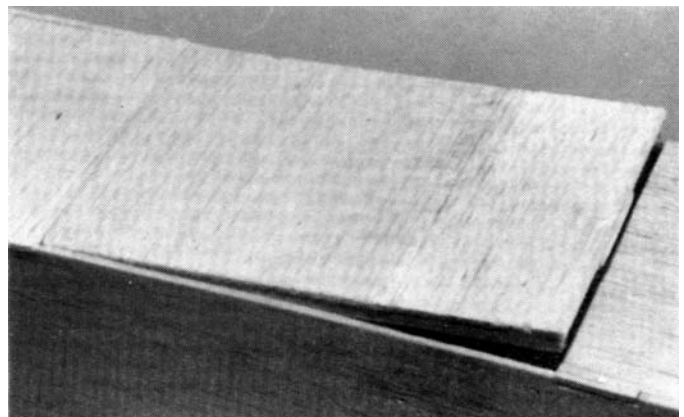

26. HATCH INSTALLATION

- Position hatch (tongue facing forwards) in fuse bottom opening. If hatch is too long, sand slightly until it fits.

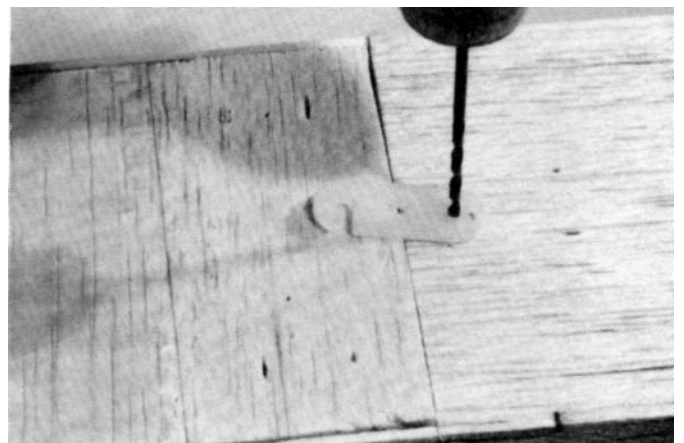

- Position nylon fastener at center of fuse, "side-action" end over hatch, the other half over the rear sheeting.
- Mark the rear hole location on sheeting. Drill 1/16" diameter hole and install nylon fastener on rear sheeting with #2 x 5/16" sheet metal screw.



#2 x 5/16" SHEET METAL SCREW

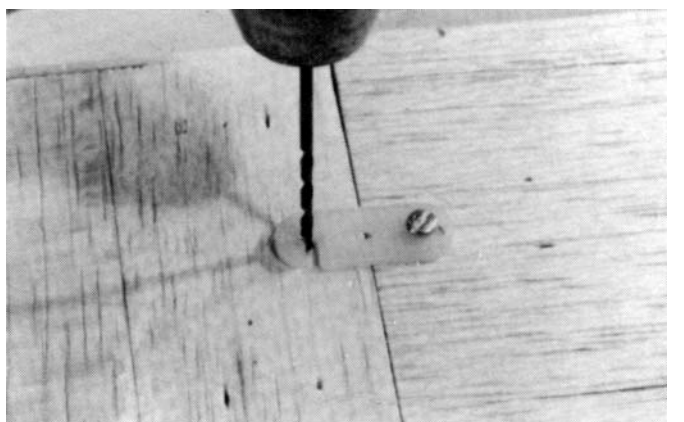

- Mark and drill hole at fastener front hole location.

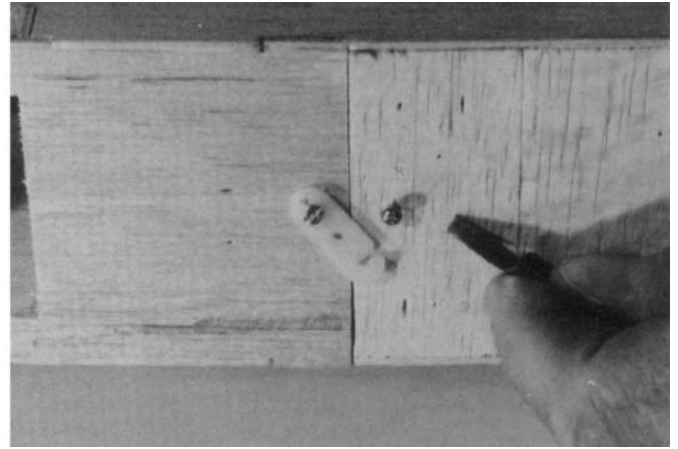
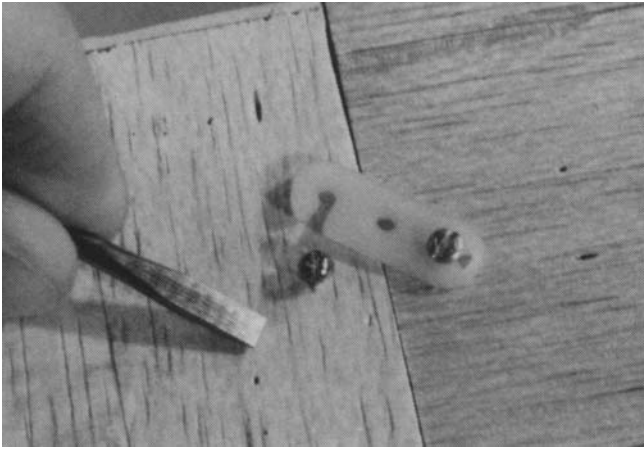

Install #2 shoulder screw exposing enough unthreaded shank to engage fastener. Snap on and off several times.



#2 SHOULDER SCREW

PUSHROD ASSEMBLY

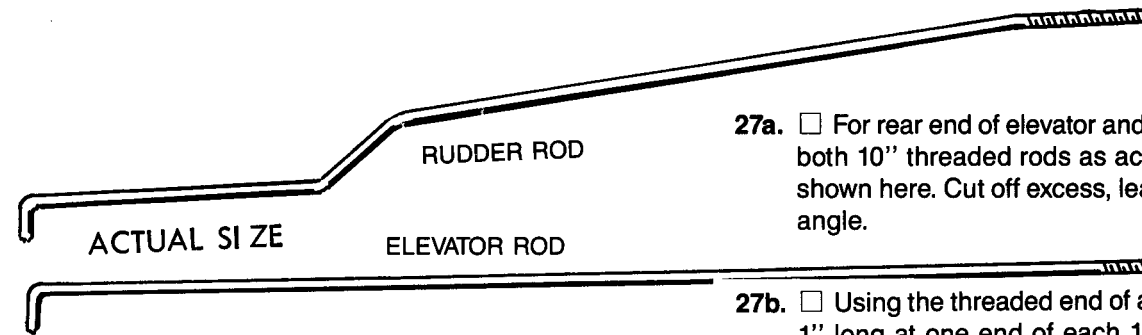

27a. For rear end of elevator and rudder pushrods, bend both 10" threaded rods as accurately as possible as shown here. Cut off excess, leaving about 1/4" at right angle.

27b. Using the threaded end of a rod, file a slight recess 1" long at one end of each 1/4" square x 16" balsa pushrod.

Drill a 1/16" diameter hole 1/4" deep at end of recess in both pushrods.

Glue rods into balsa pushrods as shown.

When dry, taper ends of pushrods and round off corners. Bind with strong thread, coat with glue and let dry.

27c. Read this instruction carefully. Complete the other end of the pushrods as follows: for the bent (rudder) rod, cut its balsa pushrod to about 13" long; for the straight (elevator) rod, cut its balsa pushrod to 14-5/8" long (refer to full-size views on plan).

27d. Cut 1/16" x 12" plain wire in two 4" pieces. Attach these wires to the balsa pushrods by repeating the procedures in step b.

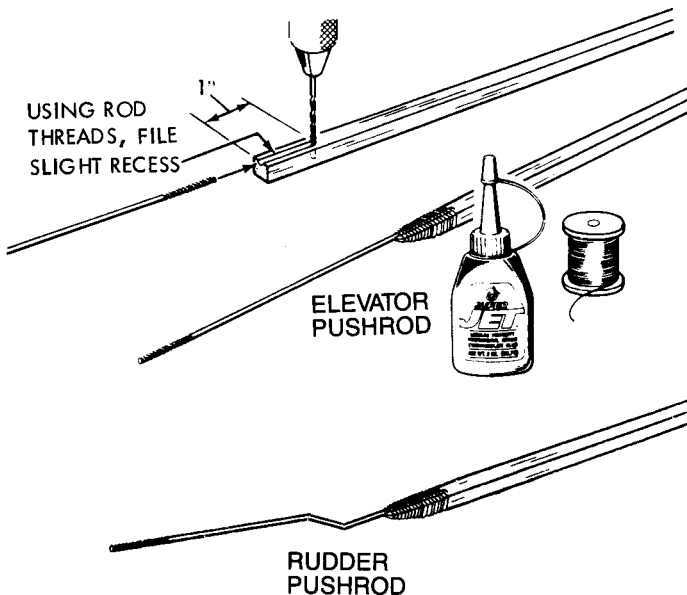

THIS COMPLETES THE FUSELAGE ASSEMBLY.

PLASTIC PARTS CONSTRUCTION

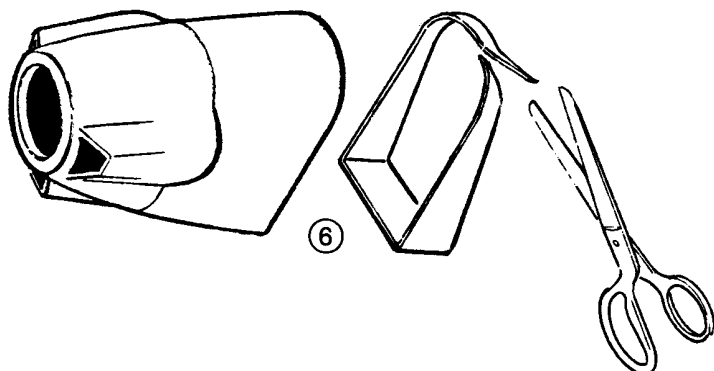
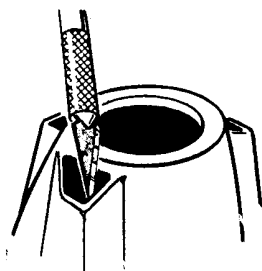
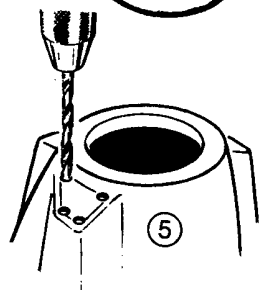
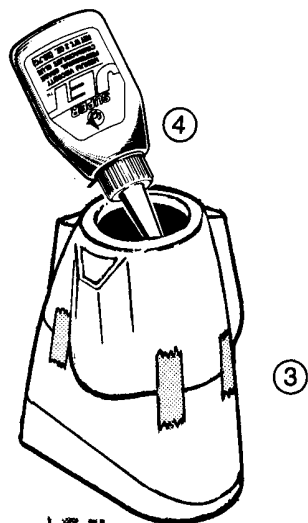
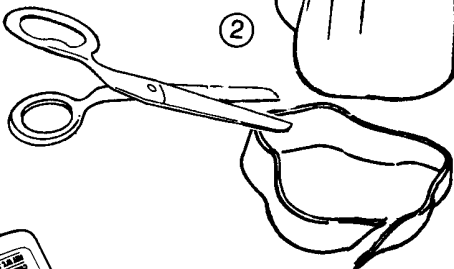
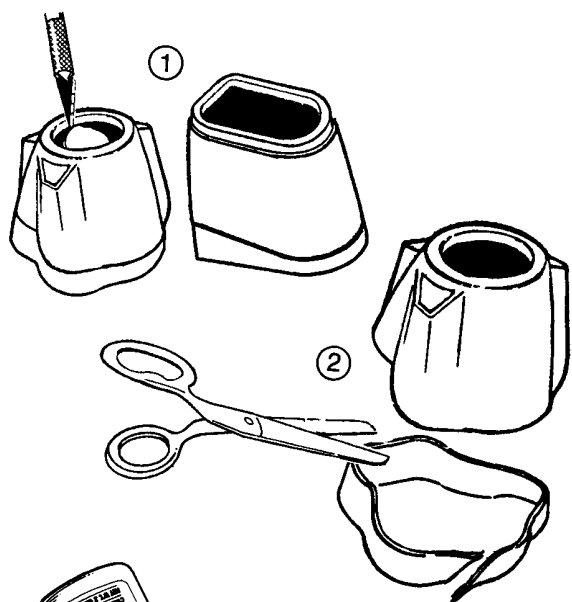

COWL ASSEMBLY

1. Carefully cut out center openings in front and rear halves of cowl.

2. Remove scrap plastic from rear of front cowl section by carefully cutting at line. Using 200-300 grit sandpaper, sand the cut edge smooth.

3. Carefully match front cowl edge over recessed lip of rear half. Tape front cowl half to rear half.

4. Through hole in cowl front, glue the joint area between cowl halves with "drops" of glue. Apply small amounts of glue so glue does not run and smear outside the cowl.

5. Carefully cut open the three cooling holes as follows:

First, drill a 1/16" diameter hole at each of the four corners of the intended opening.

Then with a sharp blade, make the opening by carefully cutting hole-to-hole. Cut the holes slightly undersize then go back and shave off the remaining plastic until you have good looking smooth straight edges.

6. Carefully cut along rear line to remove rear scrap. Sand cut edge smooth.

The cowl joint line can be left as is (most full-size airplanes have such "panel" lines). Or fill the joint and carefully sand it for a smooth one-piece look.

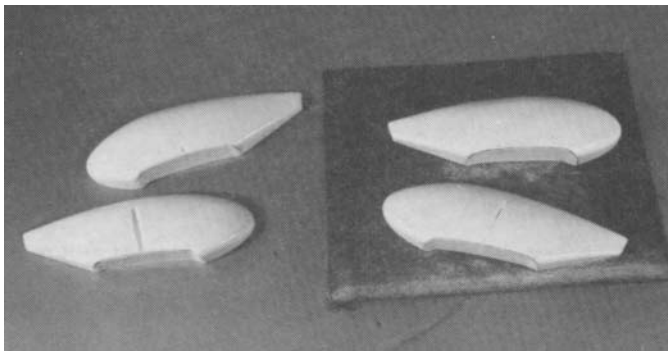

WHEEL PANTS & LANDING GEAR

1. Rub cut edge of wheel pants over sandpaper and clean burr off edges.

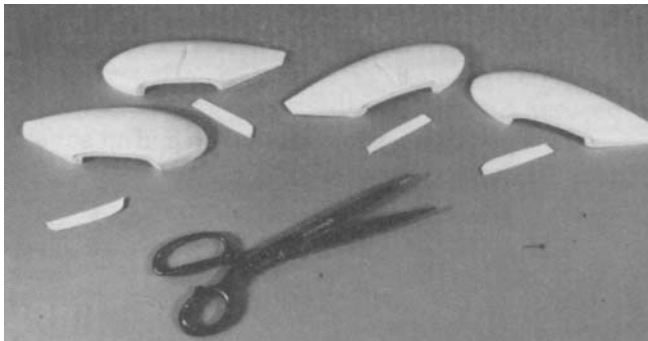

2. In the bottom of the four pant halves there is a slightly raised area, this will be removed for the wheel opening. Cut a rough opening in this area of all four pant halves as shown—but stay about 1/8" in from raised line.

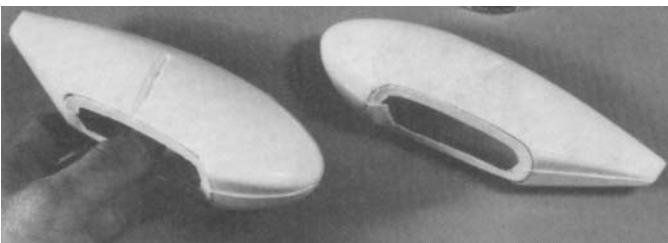

3. The pants are designed so one half fits inside the other. Position one pant half (with side slot) inside pant half without slot. Adjust parts for good fit, matching edge of outer pant with line around inner pant (about 1/16" to 1/8" overlap). Glue halves together with a few drops of Instant Jet around seam.

- Assemble other pant in same manner.

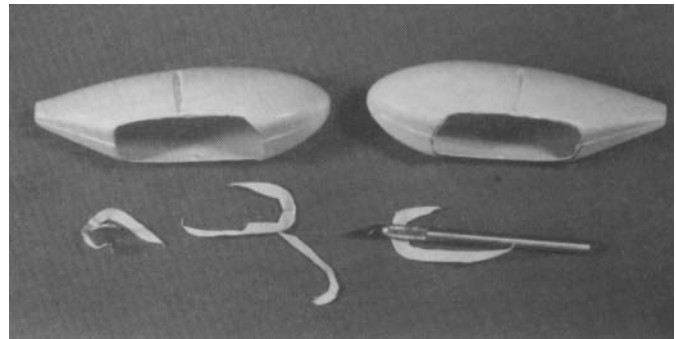

4. Enlarge rough wheel opening by lightly tracing the raised outline with a sharp knife. Work slowly, making several passes, making the cut deeper each time.

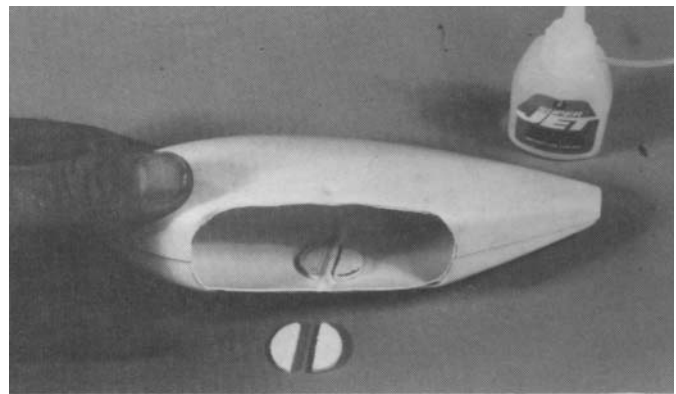

5. Glue a pair of half round ply pieces inside pant, on both sides of slot.

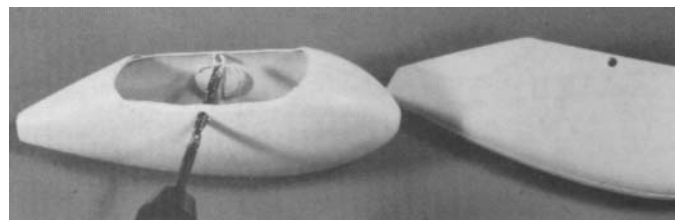

6. Using a 1/8" diameter drill, open holes on sides of pant.

NOTE: The pictured wheel pants are not those supplied with your kit. However, the construction procedure is the same.

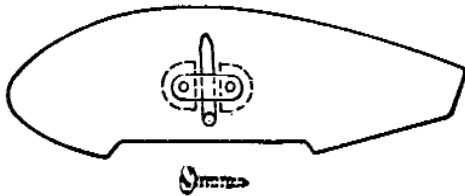
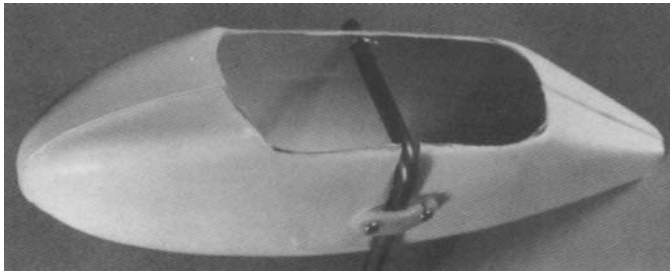

7. Insert L.G. axle (longer end) into pant. Axle should protrude out pant. Position nylon hold-down over wire at pant side as shown. Mark, drill, and mount with #2 x 3/8 sheet metal screws. If L.G. wire fits loose under hold-down, remove L.G. and glue scrap plastic shim in slot. To remove pant, simply snap hold-down off shoulder screw and rotate it away from L.G. wire.

- Reglue all pant joints using Instant or Super Jet glue.

This completes the wheel pants. They can be used as is, or, if desired, the seams can be filled, sanded smooth and the pants painted.

WINDSHIELD

FIRST SIDES

THEN TOP

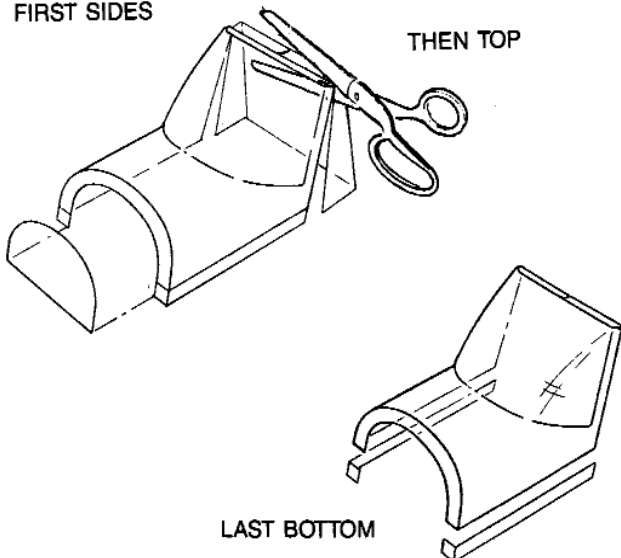

LAST BOTTOM

- Remove windshield from vac-formed sheet by cutting on lines as shown in sketches.

PAINTING THE COWL & WINDSHIELD & WHEEL PANTS

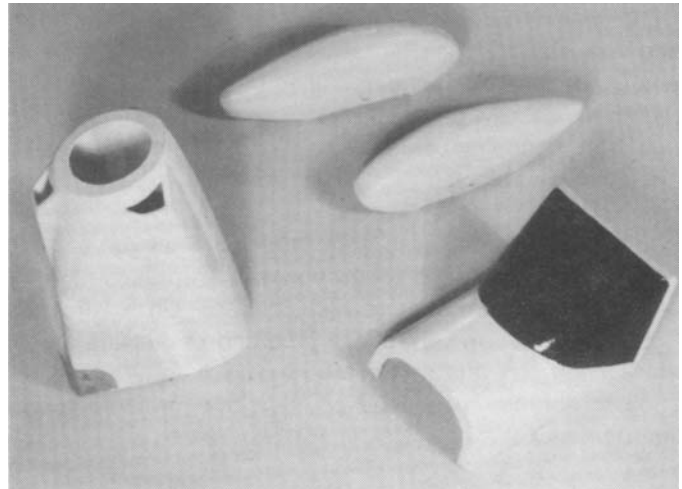

The wheel pants, cowl and curved lower area of the plastic windshield should be painted to match the color of the fuselage (or as desired).

The upper windshield area can be left clear or painted (we recommend that the upper windshield area be painted black to match the side window decals as shown on the box label. This really looks good.)

- Wash the area to be painted to remove dirt and dry thoroughly. For clear windshield apply masking tape as required.

- First apply a light "mist" coat of paint. Follow the paint instructions for "time between coats" and apply additional light coats, gradually building up the color. If you hurry and try to cover in one coat, chances are the paint will run.

- Set parts in a dust free area until dry.

- When thoroughly dry, mask and paint for additional colors if desired.

NOTE: THE COWL AND WINDSHIELD ARE INSTALLED LATER DURING RADIO INSTALLATION. PLACE THEM ASIDE UNTIL THEN.

THIS COMPLETES THE CONSTRUCTION PHASE OF YOUR MIRAGE 550. NOW GO TO THE "COVERING" SECTION IN THE GENERAL INFORMATION BOOK. AFTER THE MODEL IS COVERED, RETURN TO THIS POINT AND CONTINUE ON WITH THE INSTRUCTIONS.

Now is the time to cover the Mirage 550

COVERING

GENERAL. Any irregularities in the wood surface will show on the covering, so a good covering job should be preceded by careful sanding, filling of nicks and dents (we recommend CGM balsa filler), and then more sanding. For this final sanding, use fine sandpaper (240-320 grade) and a sanding block.

The easiest way to finish your model is to cover it in one color of UltraCote[®] and then apply trim in a second color, using either UltraCote[®] or sticky-back UltraCote *plus*. Both UltraCote[®] and UltraCote *plus* can be applied on top of each other without forming gas bubbles. (If you use another brand of covering, follow manufacturer's instructions.)

You may also paint over polyester plastic films, as well as the plastic parts of your aircraft, using modeling grade polyurethane or epoxy paints. We recommend UltraPaint[®] one-step epoxy to best coordinate with your favorite UltraCote[®] colors. For good paint adhesion, make sure the area to be painted is washed clean, dry, and completely free of any oil or dust. When painting on plastic covering, you may wish to dull the surface to be painted with 000 steel wool. Mask the design with vinyl tape.

COVERING THE WING

Before starting, carefully read the instruction that come with your covering. You will cover the bottom of the wing first, and then cover the top.

Set the covering iron to the proper temperature. Test it by laying a small strip of covering over a scrap piece of balsa and firmly pressing with the iron. Make sure the iron is hot enough to activate the adhesive, but not so hot that it burns the covering.

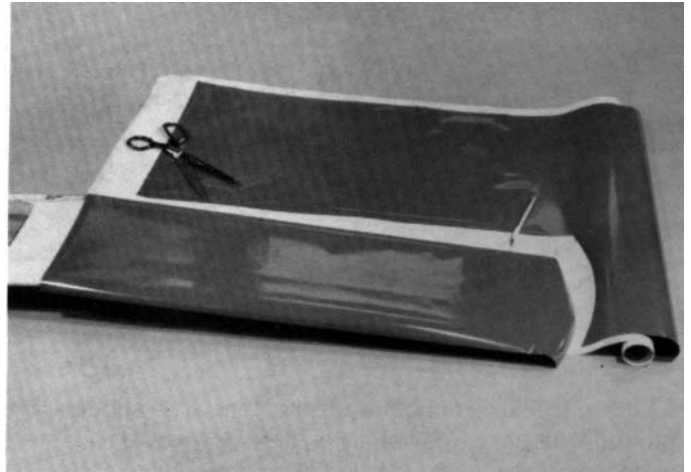

Using a fresh model knife blade or razor blade, cut a piece of covering material at least 1" larger than one-half of the inboard wing bottom panel.



Remove the protective backing paper and lay the covering over the bottom of the wing, making sure there is a slight excess for wrap-around at the L.E., T.E., and wing tip.

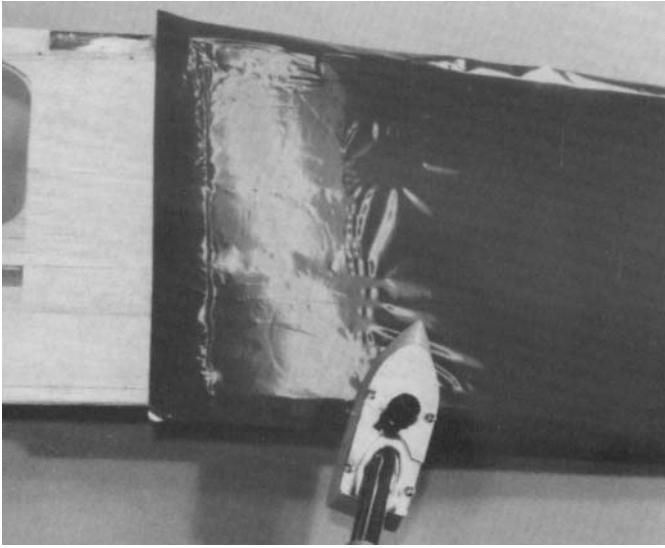

⌋ If using UltraCote, work from the center out and back to the ribs, sheeting, and other wood surfaces, using medium heat. Gently rub the covering with a soft cloth to set it in place.

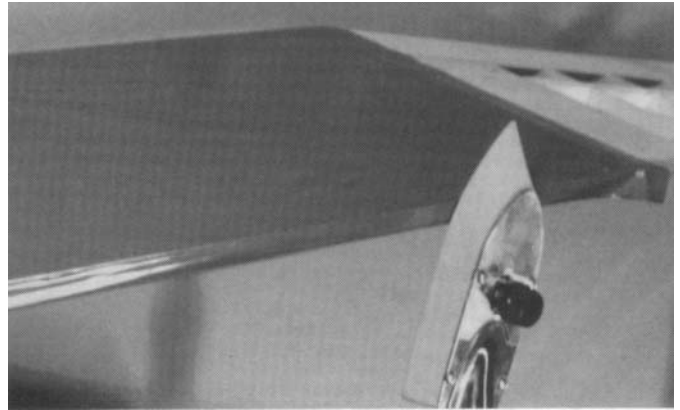

☐ Press the covering around the edges.

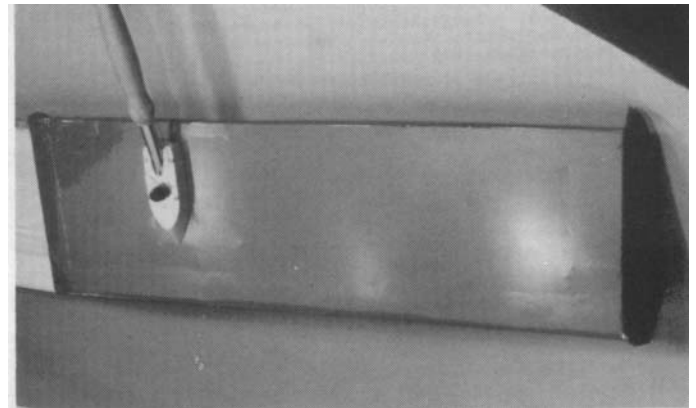

☐ Using your iron or a special covering "heat gun," using relatively high heat, shrink the covering tight.

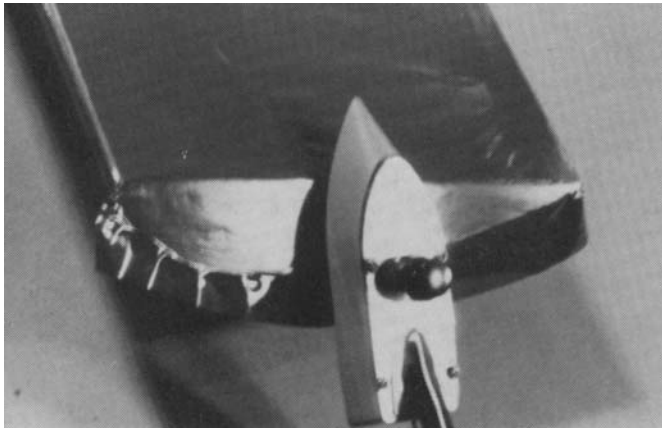

⌋ Fold the covering around the slanted side of the wing tip.

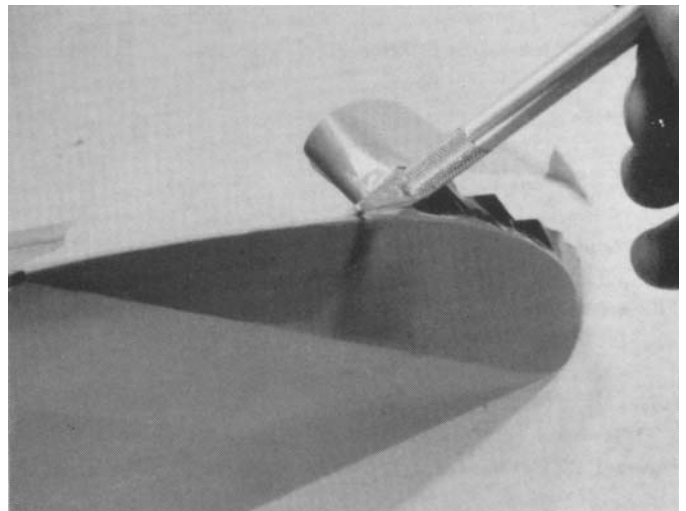

☐ Neatly trim off any surplus.

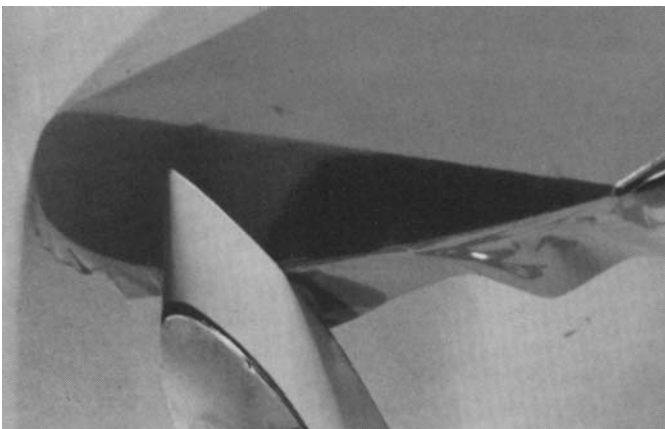

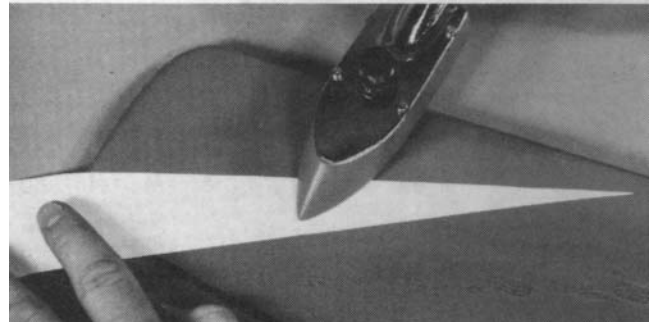
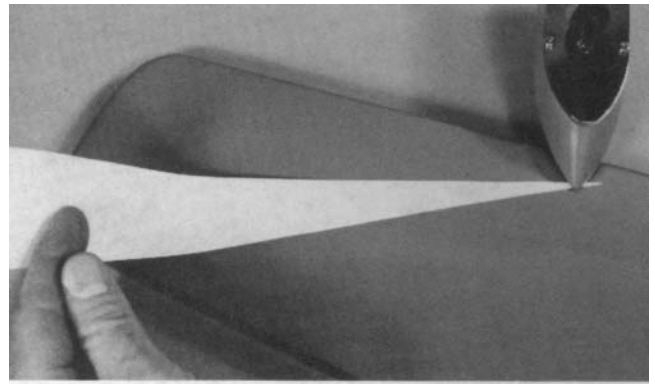
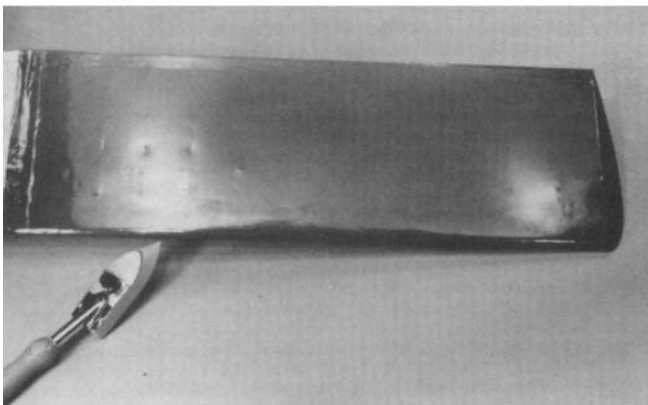
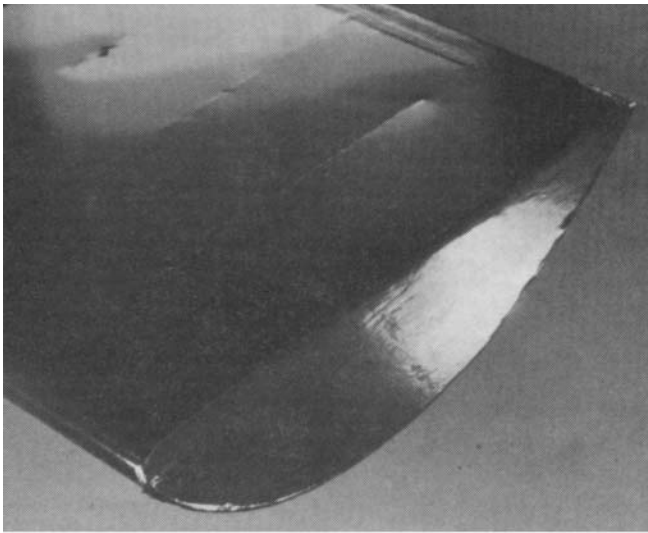

For best results, a darker color should go over a lighter one. Smaller designs should be positioned and tacked in place at one end. Then, work the iron down the rest of the design, smoothing out the design as you go. Larger designs (such as sunbursts) should be positioned and the widest end tacked down first. Then, working towards the narrow end, iron the design down.

- Following the same procedure, cover the remaining wing sections, both top and bottom. Be sure to overlap seam at least 1/4".

TRIM DESIGNS

As previously mentioned, **UltraCote**'s special adhesive does not generate its own gas bubbles when applied over itself. However, you must be careful not to trap air, so smooth the trim pieces on slowly, using low heat.

In addition to **UltraCote** and **UltraCote plus** in full-size rolls, you may purchase **UltraTrim** and **UltraStripe**, both of which have a sticky back and perfectly match the **UltraCote** and **UltraCote plus** colors.

Truing the wing is an important step, and should not be rushed or omitted.

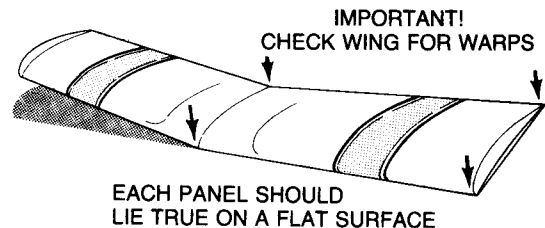

TRUING THE WING

After the wing has been covered, **you must check to make sure it is free of warps.**

- Set one half of the wing on a flat surface to detect warp. To counter any warp, twist panel slightly in the direction opposite to the warp and hold position while gliding iron over the covering to re-tension the structure. Repeat process until the panel is.

- Follow the same procedure with the other half of the wing.

COVERING THE TAIL

Following same procedure as the wing, cover stabilizer/elevator and fin/rudder. After covering over hinge holes, immediately go back and slit covering to open holes while the locations are still fresh in your memory.

INSTALLING HINGES

IMPORTANT! Read and follow hinging instructions carefully. All hinges must be firmly glued in place. Loose hinges can allow a control surface to fall off, resulting in a crash! Tug hard on each hinge to check bond.

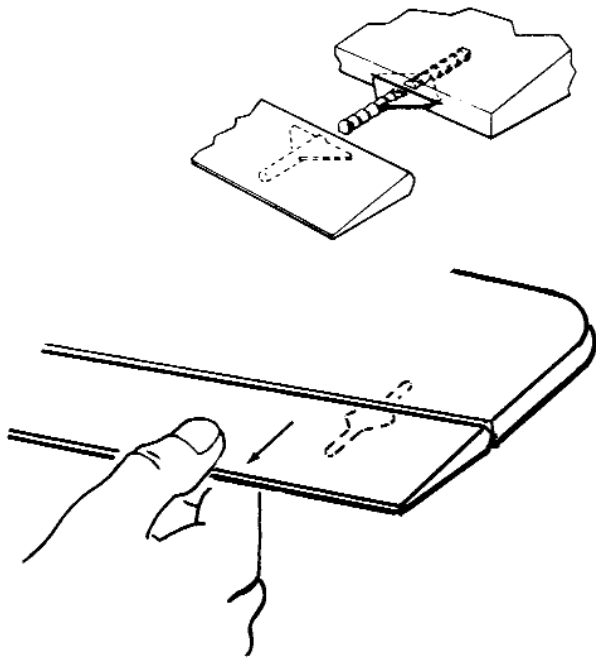

TUG HARD AT EACH HINGE, MAKE SURE EACH ONE IS GLUED SECURELY IN PLACE

The procedure is to first glue the hinges into the major parts (the wing, stab, and fin), and then add the control surfaces. Because hinge installation requires time for inserting and adjusting each hinge, quick setting SUPER JET is not recommended here. Instead, use epoxy, aliphatic resin, or equivalent glue.

Hinge elevator to stab. When dry, tug hard on each hinge to check bond.

Hinge rudder to fin.

Tug hard on each hinge to check bond.

COVERING THE FUSELAGE

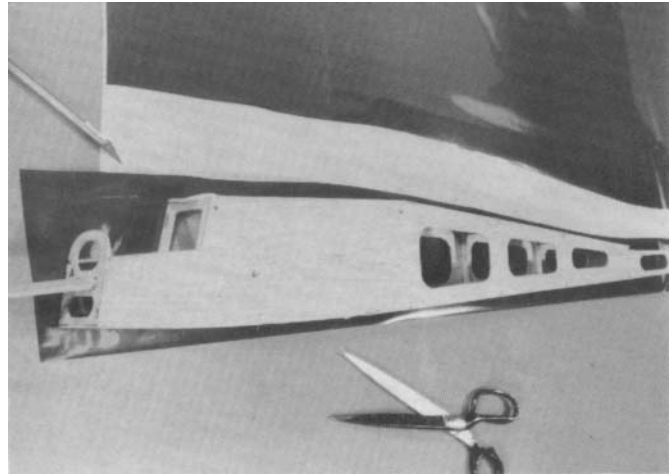

Remove screws and nylon clip from fuselage and hatch.

Mark and cut pieces for the fuselage allowing about 1" larger for handling and trimming.



Apply covering to hatch bottom. Cut corners and slit sides so covering will fold around corners.

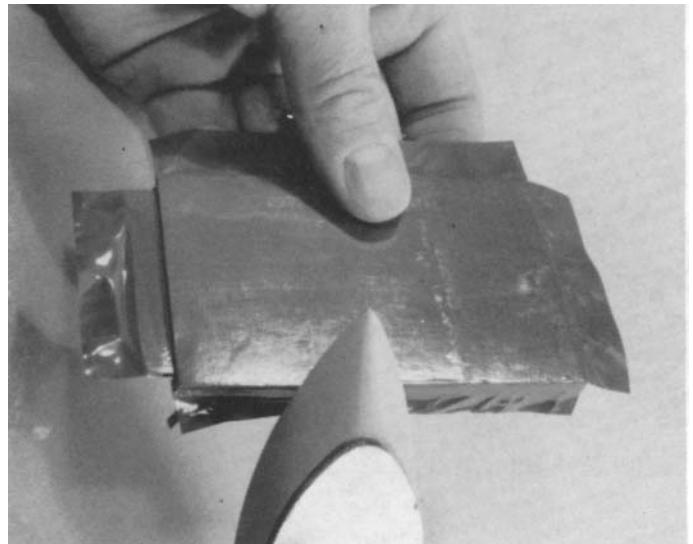

Wrap covering around edges.

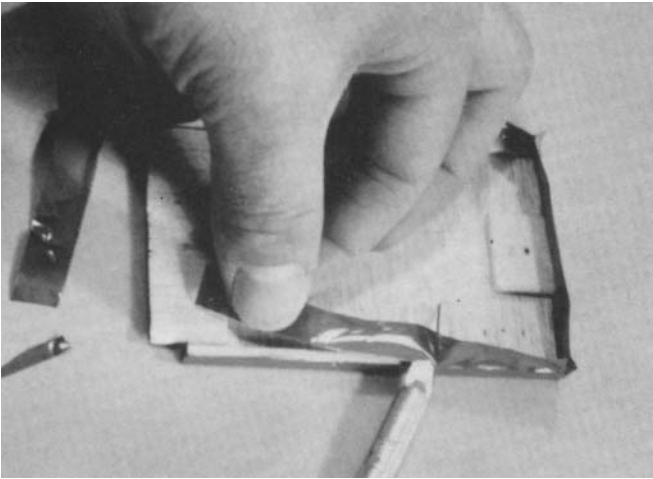

Cut and apply side covering.

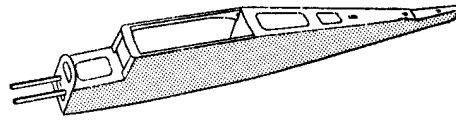

Apply top covering.

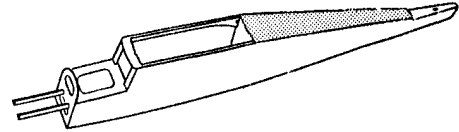

Trim covering flush with inside surface of hatch.

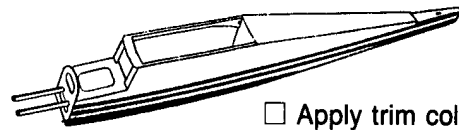

Apply trim color.

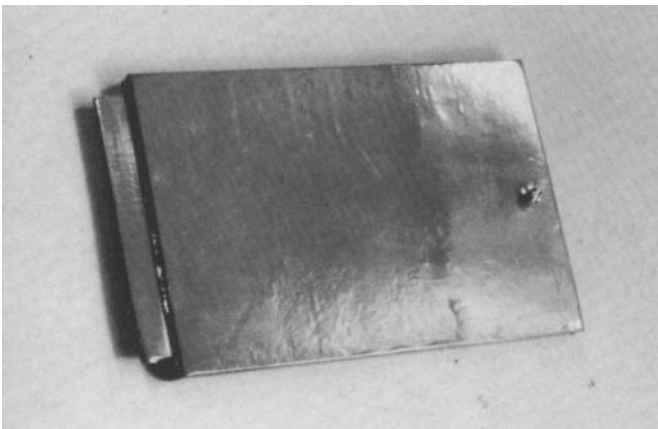

Install screw. Hatch completed.

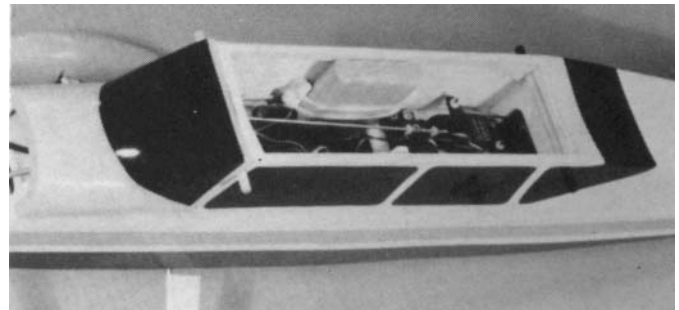

WINDSHIELD TEMPORARILY IN PLACE TO ASSIST IN ALIGNING WINDOW DECALS

DECAL INSTRUCTIONS

Clean model surfaces thoroughly before applying decals. Cut decal sheets apart in sections as needed. Fold decal in half, front to rear. Open at fold and lay decal out straight, the protective backing will bubble away from decal at fold location. Using scissors, cut backing along bubble, removing about 1" wide strip of backing. Carefully position decal on model and stick in place. Working from center, rub decal down while peeling off backing.

Cut holes through covering for wing hold-down dowels.

Insert 3/16" wing hold-down dowels through cabin with a twisting motion. Dowels should protrude an equal distance from sides of cabin. Glue in place.



Cut and apply bottom covering to fuselage.

FINAL ASSEMBLY

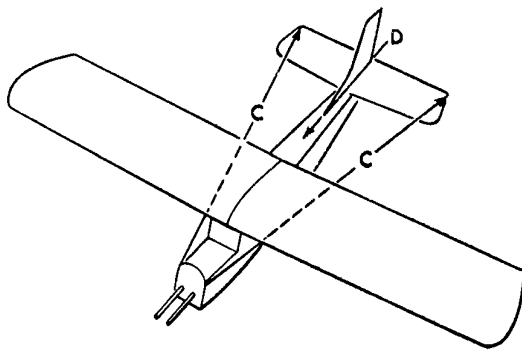
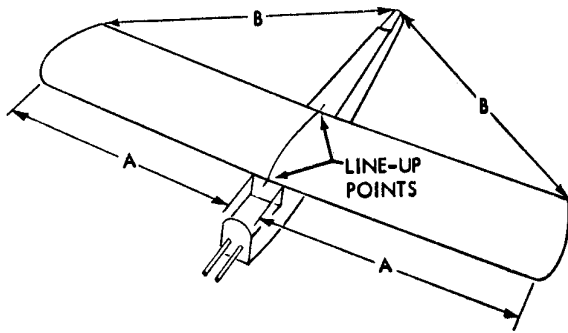

□ Mount wing on the fuselage using rubber bands. Measure carefully from the fuselage sides out to the wing tips (arrows 'A') to be sure that the wing is centered. Then measure from the wing tips to the back end of the fuselage (arrows 'B') to make sure wing is square with fuselage. Mark the wing center at leading and trailing edges, and the fuselage, with matching line-up points. Color-Stripe tape can be used for this, or certain marking pens.

□ Using no glue, trial fit stab in place on fuselage, marking it for center, and adjust as necessary to line up with wing. Then measure from the stab tips to the fuselage front (arrows 'C') to make sure stab is square with fuselage. Mark match-up lines on fuselage and stab for alignment.

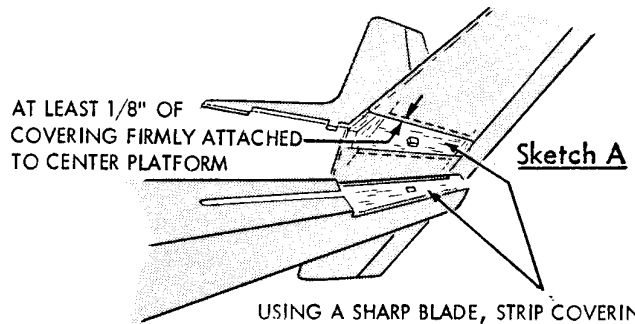

USING A SHARP BLADE, STRIP COVERING FROM STAB, FIN, & FUSELAGE WHERE THEY MATE, FOR WOOD TO WOOD GLUE JOINT. LEAVE 1/8" TO 3/16" OF COVERING FIRMLY ATTACHED TO CENTER PLATFORM. CAUTION: WHEN TRIMMING COVERING, AVOID CUTTING INTO WOOD STRUCTURE UNDERNEATH.

□ To provide a firm wood-to-wood glue joint, strip covering from bottom of stab center where stab contacts fuselage (see sketch A). **Avoid cutting structure underneath.** Be certain to leave enough covering **firmly bonded** to stab center (minimum 1/8" to 3/16"). Likewise, if stab area on fuselage was covered, remove covering. Glue stab firmly to fuselage and let dry.

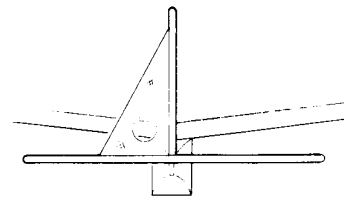

□ Trial fit fin in place on fuselage/stab (arrow 'D'). Strip covering from fin bottom (if covered) and respective area on fuselage/stab. Glue fin firmly in place, and **square** with stab. Let dry.

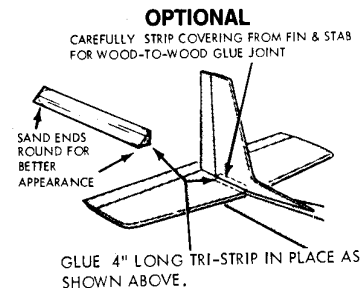

□ **OPTIONAL.** From wing tip scrap, make and glue 5/16" triangle stock on side of the fin.

Optional Tail Wheel

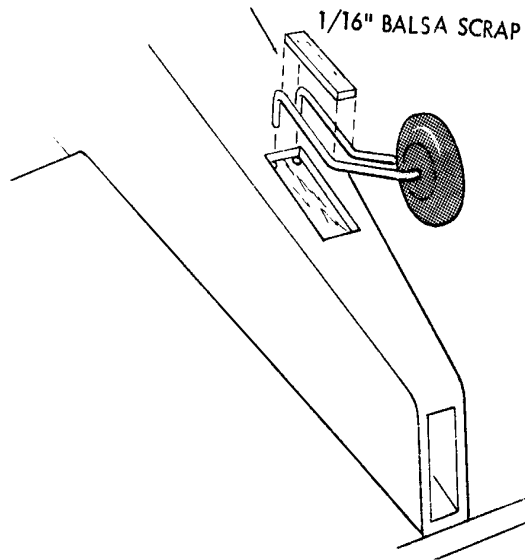

- Using a pliers, bend tail wheel wire to shape shown in sketch.
- Slide the rubber tail wheel to rear of wire.
- Remove covering to expose the recessed tail wheel mount. Glue wire ends into holes and glue wire to tail wheel mount.
- Cut a piece of scrap balsa to fill area between wires and glue in place.

MAIN LANDING GEAR

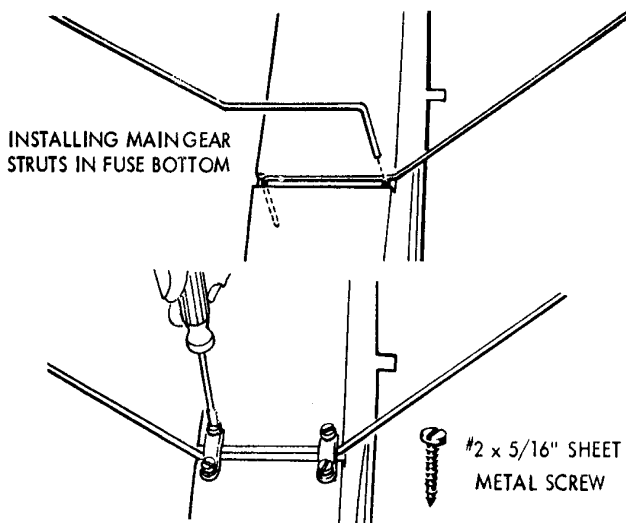

- Insert formed wire main gear struts in fuse. Position nylon landing gear straps; then mark, drill, and mount with #2 x 5/16" screws (see sketches above and illustration on page 8).

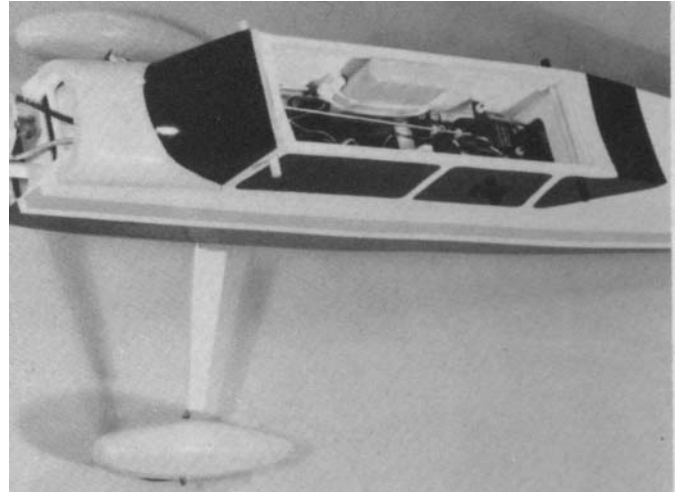
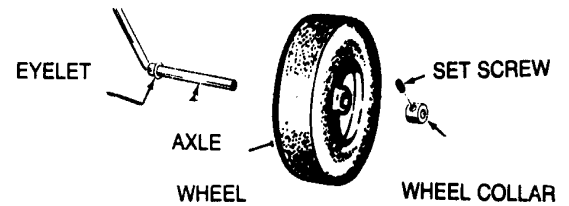

FOR INITIAL FLIGHTS AND FLYING FROM GRASS DO NOT USE WHEEL PANTS.

- Thread 1/8" set screw in wheel collar a few turns.
- Place wheel pant on axle so that axle just protrudes inside pant. Slip eyelet on axle (flange toward wheel), then slide wheel on, then wheel collar. Slide pant against vertical wire and then tighten wheel collar set screw.
- After pants are installed, fit balsa fairings on landing gear as shown on plan side view, cut to fit as required. Glue to wire gear and cover fairings.

MOTOR & RADIO INSTALLATION

IMPORTANT

PLEASE READ BEFORE STARTING MOTOR & RADIO INSTALLATION—NOT FOLLOWING THESE PRECAUTIONS CAN RESULT IN SERIOUS PERSONAL OR PROPERTY DAMAGE TO YOU OR OTHERS!

See “Balancing & Flying Your Model” section for more information.



WHEN OPERATING THE MOTOR;

- ALWAYS wear eye protection!
- KEEP safely away from spectators!
- WARNING TO PARENTS; children under the age of 12 require your supervision. DO NOT allow children to operate without adult supervision.
- PROPELLER must be securely installed to prevent excessive motor RPMs.

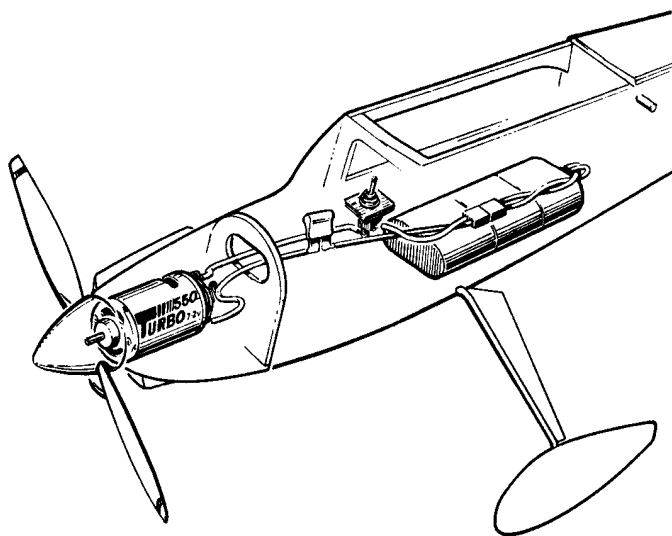

WARNING

CAUTION: BATTERY HAZARD!

The battery size used to power the Mirage motor stores a lot of electrical energy. Be careful to prevent shorting it out. A dead short can cause a powerful surge of electrical current which can ruin your battery and generate enough heat to start a fire and cause burns to you and others.

CAUTION: PROPELLER HAZARD!

The motor/battery system used to power the Mirage is very powerful. To avoid injury, always disconnect and remove the motor battery. When switched on, the motor instantly reaches full power and maximum propeller RPM. An electric motor pulls more battery energy as its work load is increased. This means, for example, that if the prop hits your hand, it not only smacks you at high speed but it also draws more battery power to overcome the added load, thus increasing the impact force and injury. It is extremely important that you are aware of these dangers and take precautions to prevent accidental switching on of the motor. This is especially important while working on the model and when storing it. Always store the model away from small children or anyone not familiar with its safe operation.

The Carl Goldberg TURBO 550 motor system is designed with a safety fuse to protect the system from excessive motor loads. During motor operation, if the propeller should hit an object, the sudden surge of battery current will blow the fuse and prevent motor/battery burn out or other damage. Use only a 15 or 20 AMP fuse to connect the fuse terminals. Do Not bypass the fuse or directly connect the terminals together—do not operate the system without a fuse!

If you will be using a motor system other than the Goldberg TURBO 550, make sure it is equipped with a fuse. If it isn't, ask your hobby dealer for advice on how to install one. If you do not follow these precautions serious personal injury or property damage will result.

MOTOR/BATTERY PRECAUTIONS

- The motor used in your Mirage is powerful and capable of inflicting severe impact, cuts or abrasions. During motor installation, ONLY connect the motor battery when instructions specify, for test purposes—DO NOT leave battery connected!
- Operate motor ONLY with propeller installed; without propeller, motor might over-“rev” and become permanently damaged. Propeller MUST be securely installed; always wear eye protection and keep away from spectators.

IMPORTANT! Installation of the Turbo 550 Motor/Harness and a typical radio control system is described here. Depending on your radio equipment or if you are using another brand of motor, you may not be able to follow the installation as shown. In that case, we suggest that you follow the manufacturer's installation instructions or ask for assistance from your local hobby shop.

1. Check List. Each Item Must Be Completed Up To This Stage.
 - Model is fully covered and painted wherever necessary
 - Control surfaces are hinged in place
 - Tail assembly is glued solidly to fuse.
 - Stab and rudder pushrods complete

BALANCE NOTE. A final balance check will be made later on. Most all brands of equipment when installed as shown will result in a properly balanced condition.

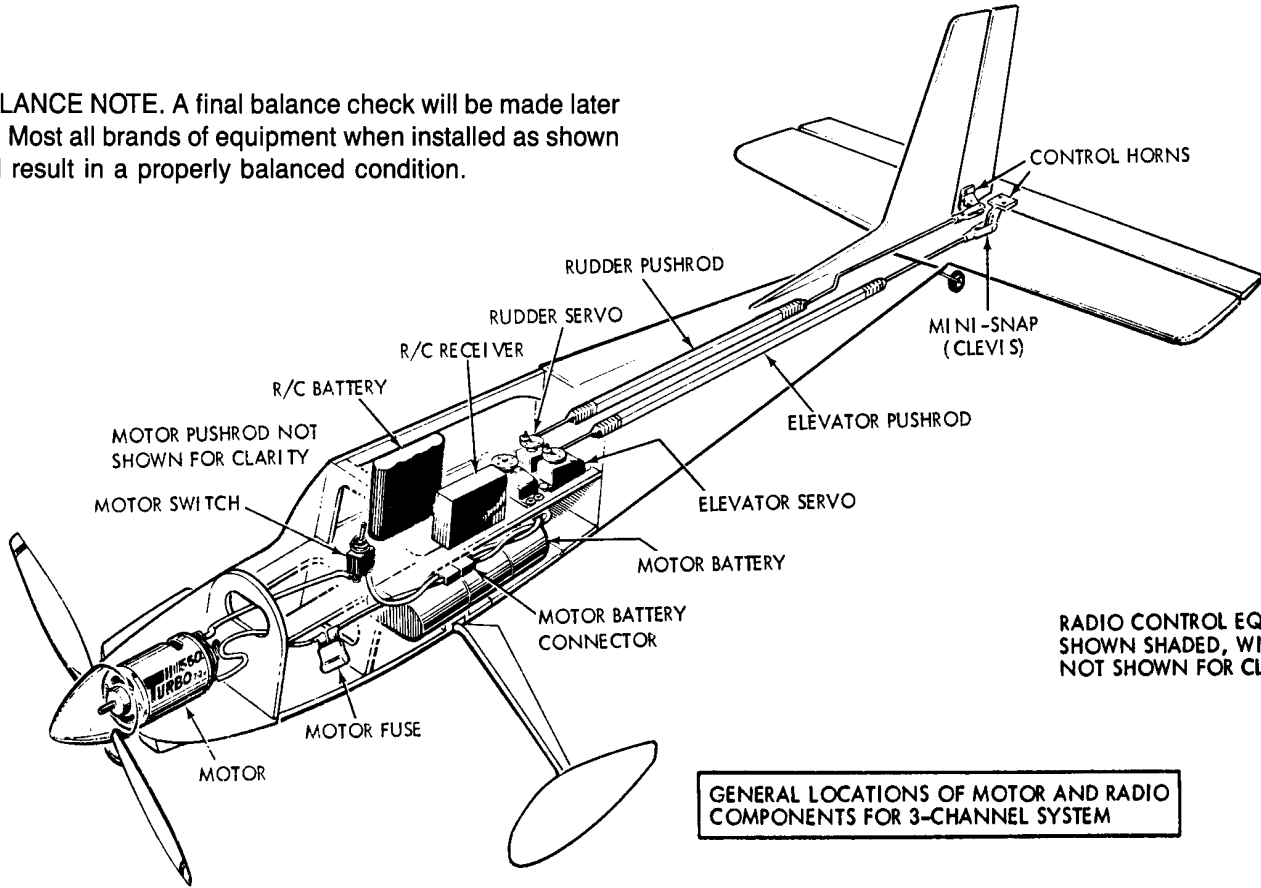

RADIO CONTROL EQUIPMENT SHOWN SHADED, WIRING NOT SHOWN FOR CLARITY

GENERAL LOCATIONS OF MOTOR AND RADIO COMPONENTS FOR 3-CHANNEL SYSTEM

WHEN HANDLING THE MOTOR & SWITCH HARNESS, TRY TO AVOID BENDING THE WIRES NEAR THE SOLDERED CONNECTIONS. IF HANDLED CARELESSLY, SOLDERED JOINTS CAN BE BROKEN.

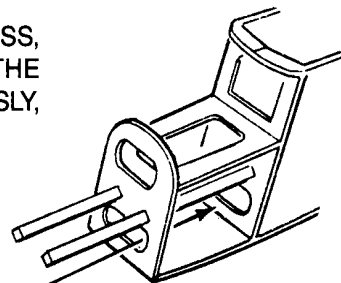

- 2a. Insert motor wire harness into fuselage through lower opening in Formers "A" and "B" (temporarily rubber band battery connector to a strip of scrap plywood to help feed harness through holes).

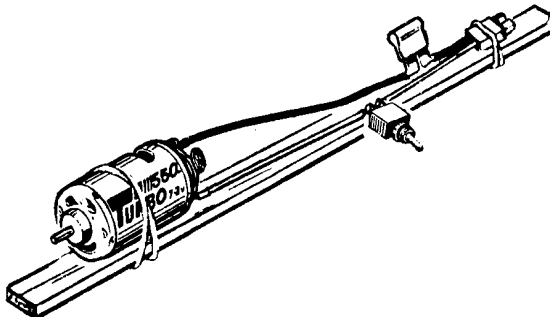

TO PREVENT ACCIDENTALLY SWITCHING ON THE MOTOR—DO NOT CONNECT THE MOTOR BATTERY UNTIL INSTRUCTED TO DO SO!



Hold motor on mounts with a rubber band. Position motor so it is about 7/8" ahead of Former "A." To prevent motor from shifting backwards, make two small "stops" from scrap wood. Glue "stops" to motor mounts.

For alternate 2-channel installation, proceed directly to Step 2c.

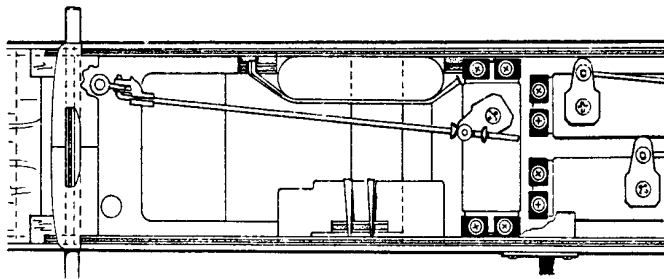

2b. For 3-channels, install motor switch in right side hole in ply servo mount as shown. Hold switch with star washer and nut. As you tighten the nut, turn the switch slightly so switching action aligns with pushrod from motor servo as shown in fuse top view.

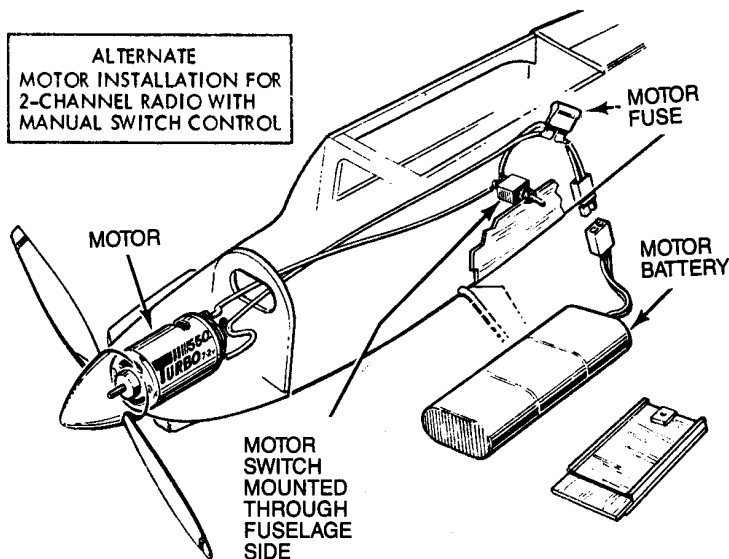

2c. For 2-channels only, glue ply switch mount inside fuse at location shown on FUSELAGE SIDE VIEW on plan.

From inside fuse, push a pin through the mount hole to show its location on the fuse side. Using a sharp razor knife, cut a round opening through fuse side to match mount hole.

Install motor switch in fuse side.

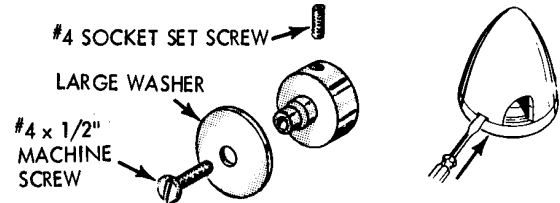

2d. Position cowl assembly on front of fuselage.

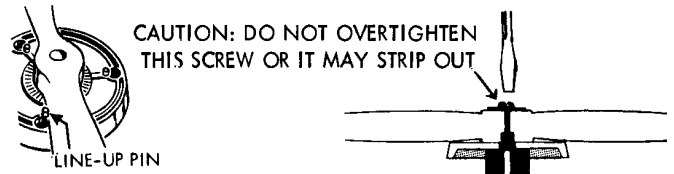

2e. Thread #4 x 1/4" socket set screw in aluminum mount a few turns.

Open spinner by carefully pushing small screwdriver straight into all slots — DON'T TWIST! Place spinner backplate and propeller on mount. Set prop against "line-up" pin and install large washer and #4 x 1/2" machine screw—CAUTION: DO NOT OVERTIGHTEN or threads may strip out!

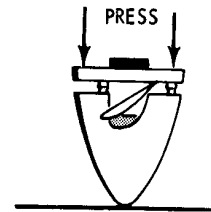

2f. Align spinner cone with prop/backplate and press pins firmly into holes. One way to do this is to place the spinner pointed down on a table and press from behind the backplate until all three pins are seated.

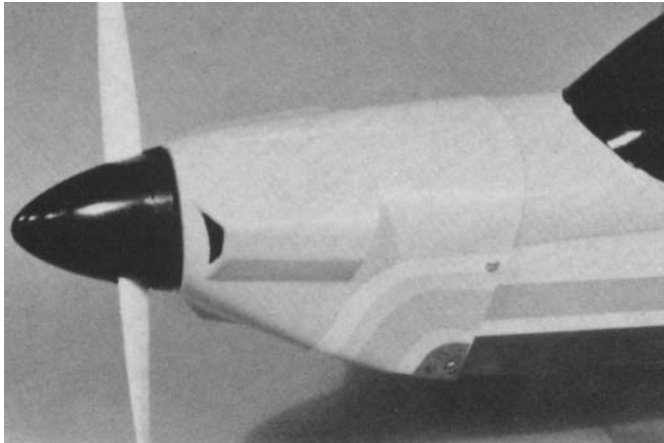
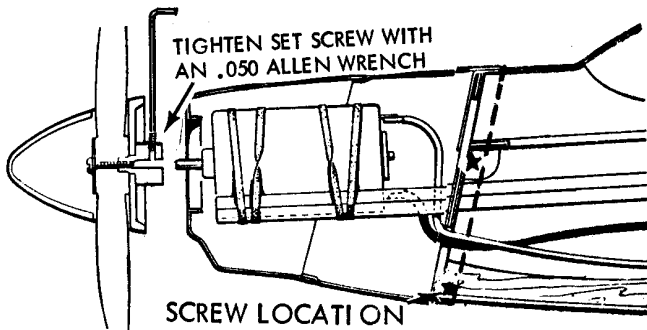

- Install prop/spinner assembly on motor shaft and securely tighten set screw with an .050 allen wrench.
- Align the cowl behind the spinner backplate allowing about 1/8" clearance. Holding cowl in this position, drill for 1/16" holes through cowl into fuse sides at screw locations shown on plan.
- Install #2 x 3/8" sheet metal screws at cowl mounting holes. After mounting screws, remove them and spinner/prop and cowl. Apply a drop of Super Jet in each hole to "harden" the threaded wood (open holes with a pin before glue dries).

WARNING: A SPINNING PROPELLER CAN CAUSE INJURY—WEAR SAFETY GLASSES AND OPERATE AWAY FROM SPECTATORS!

3. RADIO INSTALLATION

- A.** Read and follow the instructions that came with your radio.
- B.** If your batteries are dry cells, they should be fresh (we recommend Alkaline batteries). If rechargeable nicads, they should be fully charged.
- C. Hook-up Radio and Try Operation.**
 - Refer to "Transmitter Function Sketch," and observe which servo wheels move when stick is moved for various controls.

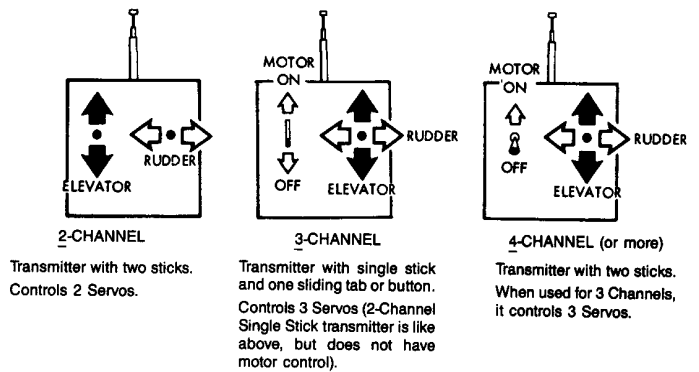

TRANSMITTER FUNCTION SKETCH

Your transmitter is built like one of those illustrated below. Each sketch shows how the sticks are moved to control various parts of the model.

- Apply tape (which you can write on) to each servo. Identify each servo for its control function. Mark the plug to each servo the same way: "R" for rudder, "E" for elevator, "M" for motor. If your receiver doesn't have separate plugs for each servo, but places for the servos to plug in, apply a piece of tape nearby that you can mark for each application (some receivers are labeled for servo functions).

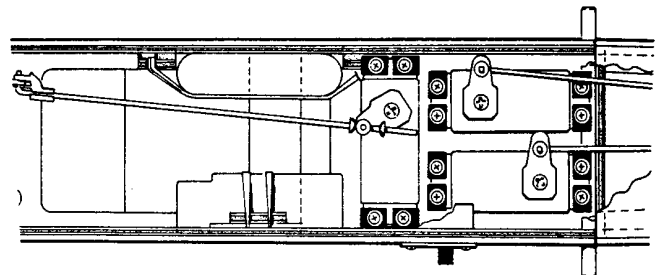

"REVERSE" SERVO CAN BE IDENTIFIED BY A DOT IN MOUNTING FLANGE AS SHOWN HERE, OR A DIFFERENT COLOR CASE OR MARKINGS.

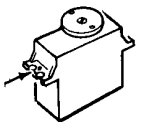

4. SERVO ARRANGEMENT

We recommend that you position your servos as shown on the plan TOP VIEW. Motor servo in forward opening (output wheel towards right side), rudder servo in right rear opening and elevator in remaining left rear opening.

Note: in radio sets without "servo reversing" feature, the rudder servo is usually a "reverse" servo. A "reverse" servo can be identified by a dot, or a different color case or markings.

- With motor servo at forward position, place servo so output wheel is on same side as motor switch.

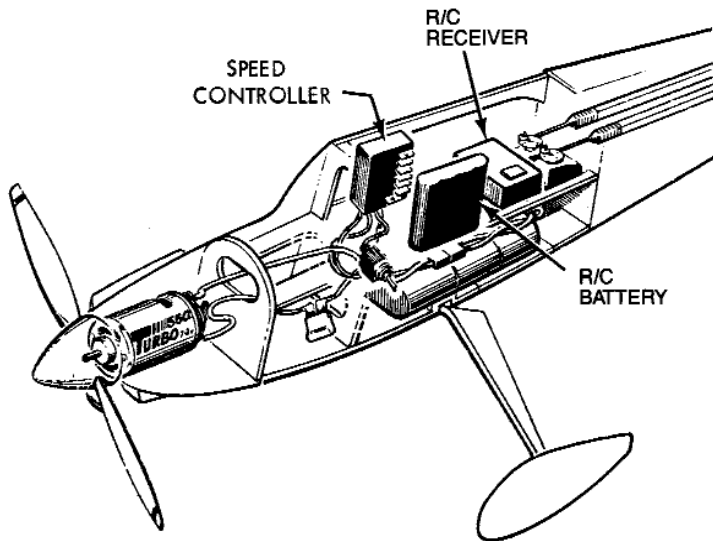

ELECTRONIC SPEED CONTROL OPTION

TYPICAL ELECTRONIC SPEED CONTROL INSTALLATION

When installing a speed controller, the R/C equipment can't be installed exactly as shown on the plan. A typical controller installation is described here. This is meant to be a guide, you may not be able to install your equipment exactly as we show.

Position the receiver over the motor servo space. The speed control should be positioned on the side of the fuselage to allow for best cooling airflow, this is important. The speed control is connected to the receiver "throttle/motor" terminal. You may have to solder on new connectors to match with your radio, ask your dealer. The heavier wires connect to the motor and battery. Mount the "on-off" switch through the fuselage side as a safety "arming" switch.

WARNING

Some controllers can cause radio interference with resultant loss of radio control. So be sure to do a thorough range check of your model with the speed controller operating before flying (see range check in General Instruction Booklet, page 13).

CONTROL MOVEMENTS ARE THE SAME AS IN A FULL-SIZE AIRPLANE

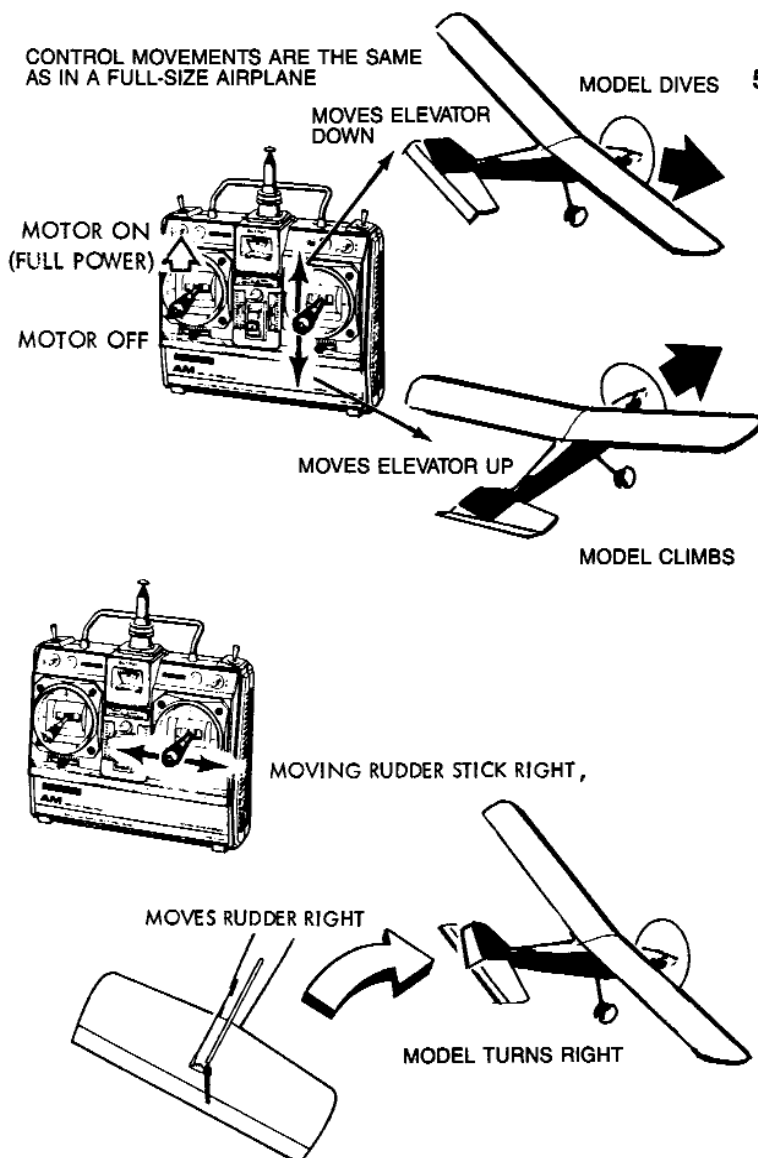

5. SERVO MOVEMENTS

As mentioned in the introduction on page 2, radio systems with "servo reversing" simplify radio installation. With a **regular non-reversing** system, you must match each pushrod to its corresponding servo's rotation. With "servo reversing," pushrods can be hooked up to either side of the servo's output wheel, and after checking the control response, a servo responding in the wrong direction is easily switched to correct action (see your radio manufacturer's instructions).

The servo arrangement on the plan is recommended for either "regular" or "servo reversible" systems. For **either** type of radio system, check your equipment out with the following procedure.

Push the transmitter (Tx) motor lever up away from you, and observe where motor servo wheel should connect to the motor pushrod to move switch to "on" position. Mark this on the servo wheel (write on tape). Return motor lever to full down (off position).

Move the elevator stick up, and observe where the elevator pushrod must be attached to the elevator servo to pull the elevator down. Mark servo.

Move rudder stick to the right, and observe where rudder servo wheel should connect to give right rudder and nosegear steering. Mark this on the servo wheel. Remember, for non-reversing radios, that the rudder servo usually needs to be a "reverse" servo.

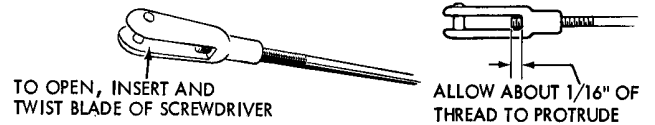
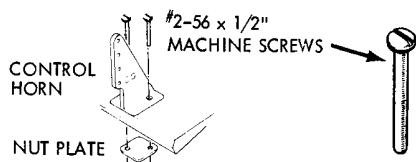

6. MOUNTING THE CONTROL HORNS AND PUSHRODS. RUDDER HORN

- Refer to fuse side view on plan for correct location.
- Tack-cement control horn on correct side of rudder.
- Drill through holes in horn, and mount nut plate on other side using screws as shown. Trim screws flush with nut plate.

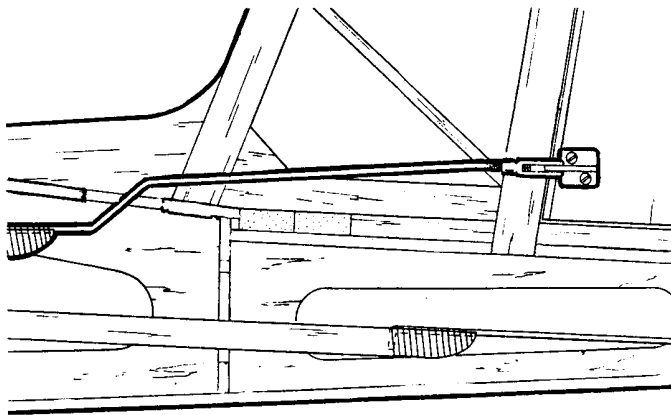
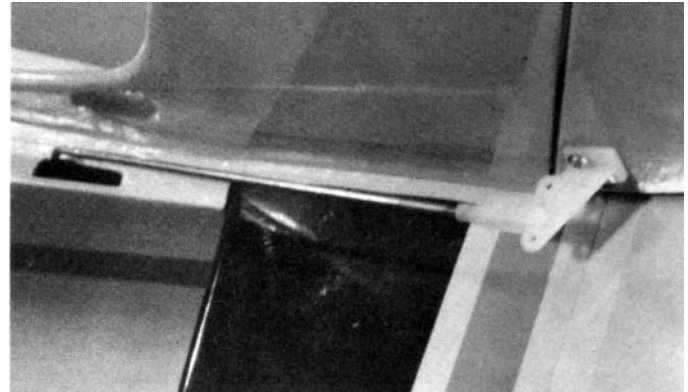

- Remove covering from die-cut hole in fuse top (adjacent to dorsal fin) for rudder pushrod.

- Lay pushrod over pushrod views on plan, and make bends as required. Working from cabin, feed rudder pushrod (threaded end) through fuse rear and out exit hole. Use a loop of string or wire to pull threaded end up through exit hole.

- Twist mini-snap (clevis) onto threaded rod. Hold pushrod wire with pliers while installing mini-snap. Connect to rudder horn.

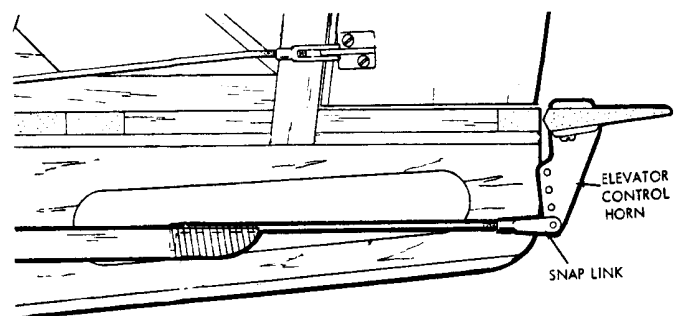

ELEVATOR HORN

- Insert threaded end of elevator pushrod from cabin through fuse rear and out slot opening about 2".
- Install mini-snap on rod, and connect to elevator horn.
- Position horn under elevator—refer to plan for correct position. When horn is centered so mini-snap moves in and out of tail opening without scraping sides, mount horn on elevator.

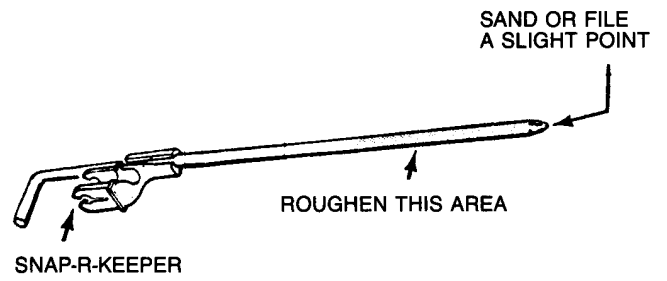
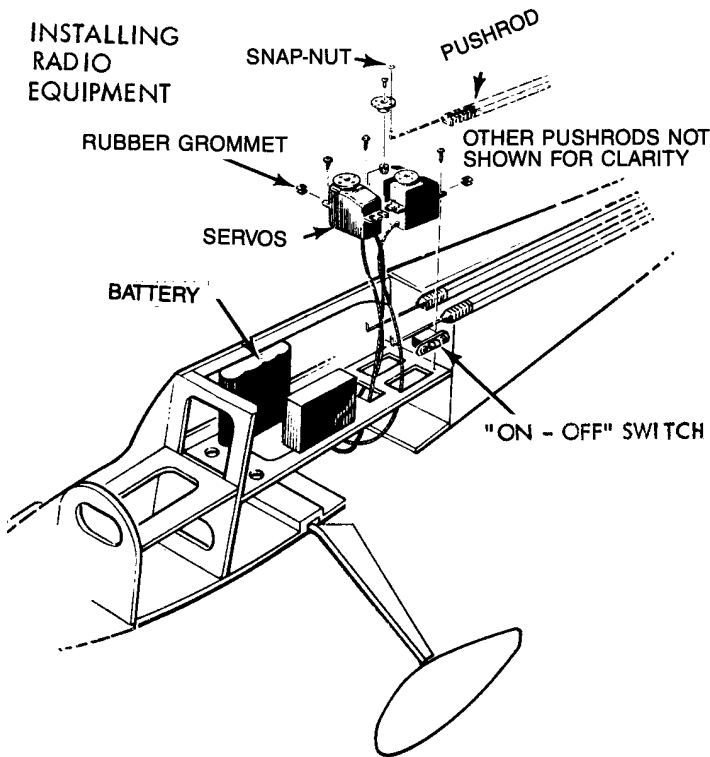

- Point one end of the 1/16" x 6-3/8" wire included.
- Make a 1/4" 90° bend at the opposite end.

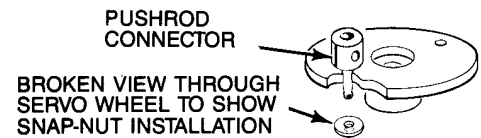

- Remove servo wheel, and install the CG Pushrod Connector as shown. This device lets you easily adjust motor pushrod movement. Remount the servo wheel with the pushrod connector in approximate position shown in top view on panel.

MOUNTING SERVOS

7. Tape front end of rudder and elevator pushrods up out of the way under top doublers.
- Insert the soft rubber grommets into the mounting holes of your servos and tray.
- Correctly position servos in tray. Mark through the grommets for the location of the mounting screws. Remove the servos. With a 1/16" drill bit, drill holes in tray.
- Reinstall servos and gently fasten them in place with screws provided with your radio system (or with #2 x 3/8" sheet metal screws).

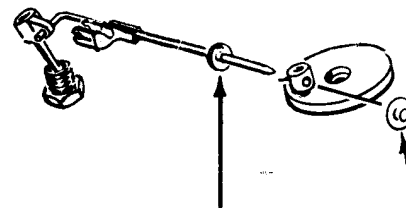

TRIM FOR SERVO WHEEL CLEARANCE IF REQUIRED

POSITION FLANGE PARALLEL TO SWITCH ACTION

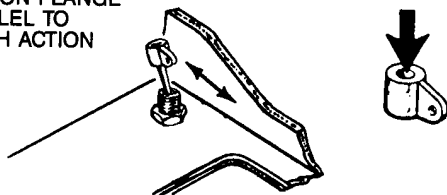

INSTALLING THE MOTOR SERVO AND PUSHROD

8. Using a model knife or a 7/64" drill, enlarge the nylon bracket to fit snug on the toggle switch stem. With bracket flange parallel to the switching action, glue the bracket to the switch. Be very careful not to get glue into switch!

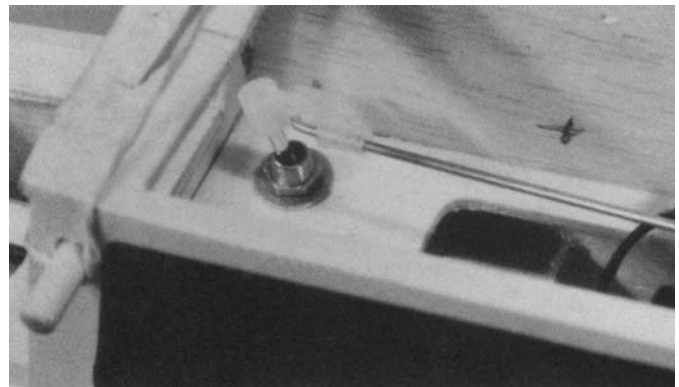

- Press on, and slide down a CG snap-nut to the straight end of the wire.
- Insert the wire through the pushrod connector and add the remaining snap-nut.
- Connect the bent end of the wire to the switch bracket and slide the Snap-R-Keeper down over the wire.

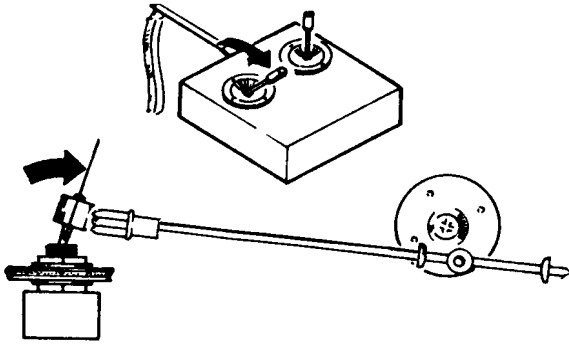

- Plug the servo into the receiver and turn on both transmitter and receiver.
- Position the throttle control to "power off" or "low motor."
- Position the toggle switch to "off."

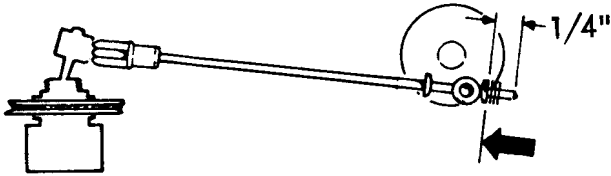

- Slide the rear snap-nut forward to touch the connector body.
- Cut the wire pushrod 1/4" away from the rear snap-nut.

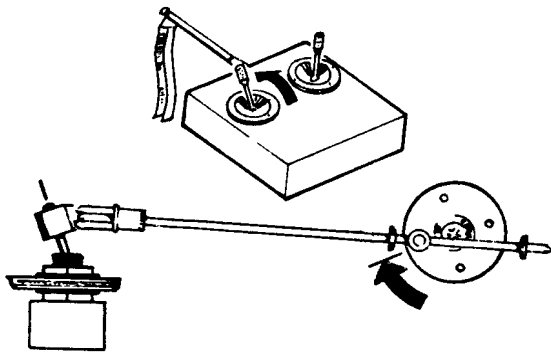

- Advance the throttle control to "power on" or "high motor."
- Flip the toggle switch.
- Slide the forward snap-nut up until it just touches the connector-body on the servo.



- Turn off the receiver and then the transmitter.
- Disconnect the motor control servo from the receiver.

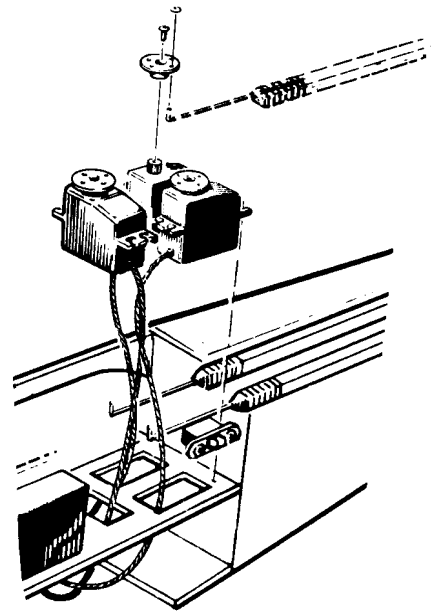

9. HOOKING UP ELEVATOR AND RUDDER PUSHRODS

- Position elevator pushrod so that the elevator T.E. is centered with stab. Allow additional 5/16" past servo wheel hole, then cut and bend forward end of pushrod. Roughen bend-up wire with sandpaper, remove servo wheel and insert wire, and retain with snap-nut.
- Position rudder pushrod so that the rudder is aligned with fin. Cut and bend forward end of pushrod as above, and attach to rudder servo wheel.

10. INSTALLING SWITCH AND CHARGING JACK

- Position switch (and optional charging jack) cover plates on outside of fuse as shown of fuse side view of main plan sheet. Mark through cover plates for holes and openings.
- Make holes through fuse side. Make sure hole for switch bottom is long enough for it to move to ON and OFF positions.
- Install switch and jack.
- Later, when radio is operating, identify ON and OFF positions with decals provided. Preferred "ON" position is forward.

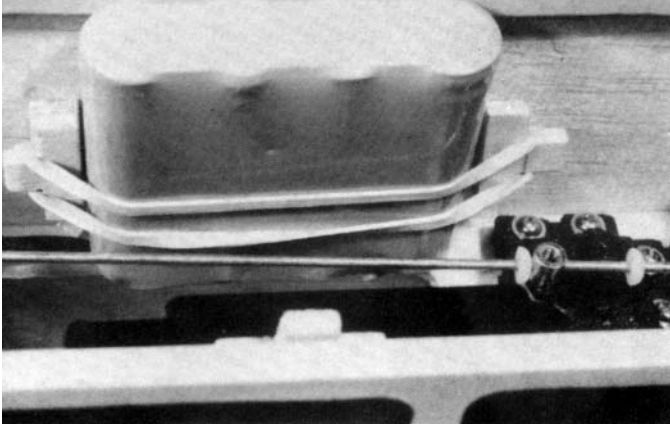

11. BATTERY PACK

- You must have fully charged nicads or fresh dry cells for flying.
- Make four rubber band retainers from die-cut ply "T" shapes and scrap 3/16" balsa as shown.
- Position battery on right fuse side as shown in photo and in Top and Bottom Views on plan. Glue two retainers to fuse sides as shown to hold battery. When glue has dried, rubber band battery in place.

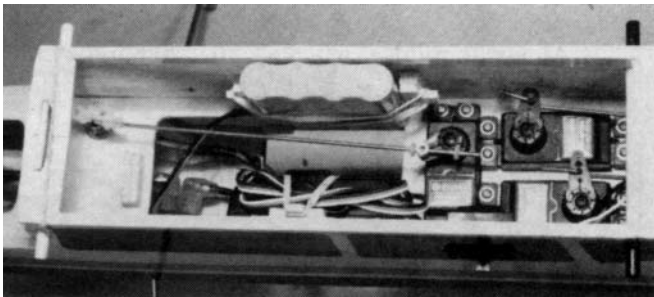

12. Receiver (Rx)

- Do not cut the antenna wire attached to the Rx.
- Reconnect all cables so R/C system is operational: be sure that each servo is plugged into its respective Rx terminal.
- Position Rx on left fuse side as shown on plan.
- Lead the antenna wire up and back along cabin top doubler and then out through tail end of fuse. Tape wire inside cabin. Tape end of antenna to fuse tail end.

NOTES

13. SETTING CONTROL SURFACES

All pushrods must move freely, without binding; adjust if required for smooth operation. When setting control travel, be cautious that no servo is hooked to a control in a manner that prevents the servo wheel from moving through its complete range of rotation. For example, if the motor servo “buzzes” when moved to “on” or “off” position, the servo still has movement left, but is jammed against the switch limit position. This can damage the servo and drain the battery, leading to loss of control, and a crash.

Move motor lever on Tx to cycle the throttle from idle to full power. Adjustments can be made by shifting the snap-nut locations on the pushrod.

The following instructions describe how to set the control surfaces measuring up and down movement using the angle templates provided. For first flights, it is recommended that you set controls per the angle templates for “softer” control response. Later, after you are more familiar with the airplane, you can always increase the throws as you prefer.

With elevator trim tab on Tx set in center, adjust elevator Mini-Snap until elevator T.E. is centered with stab as shown.

Move the elevator stick on Tx full up and down. The elevator should move to match template angles, up and down.

With rudder trim tab on Tx set in center, adjust Mini-Snap until rudder T.E. is centered with fin. Nose wheel should point straight ahead.

Move the rudder stick on Tx full right and left. The rudder should move to match the rudder template angle, left and right.

THIS COMPLETES THE RADIO INSTALLATION.

INSTALLING WINDSHIELD

You have two options for windshield mounting. Permanently glue it in place. Or make it removeable using #2 screws to hold it in place as shown in photo. A removeable windshield makes it easier to work inside the forward fuselage.

For a glued on windshield, temporarily set it in place on fuse and note where the outline contacts fuse. For good gluing, lightly sand covering in this area—light sanding only, just dulling the surface. Glue windshield in place (after Super Jet has dried, a trace of white film may appear inside a clear windshield—this can be wiped off with a damp rag).

CUT GAUGES FROM PLAN

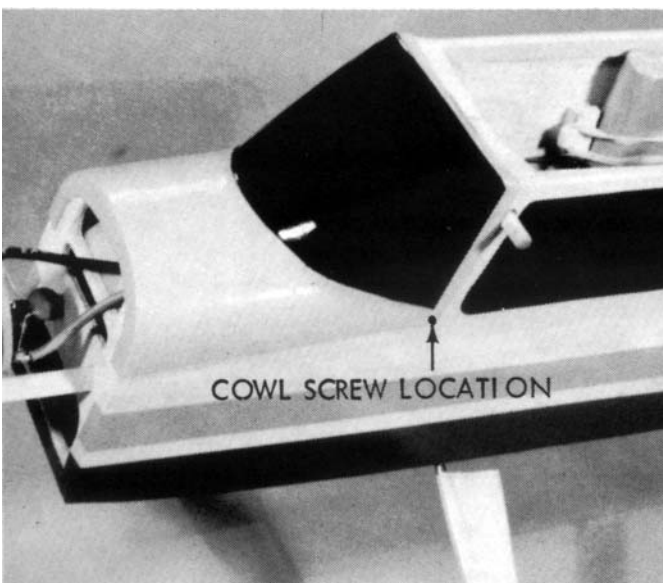
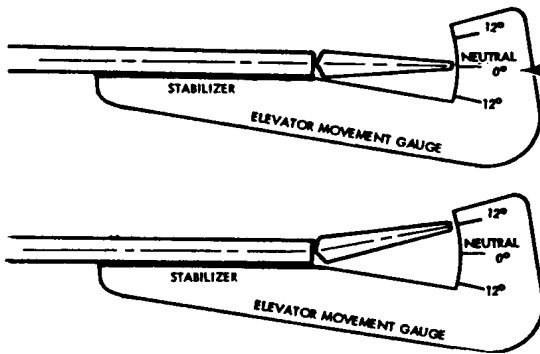
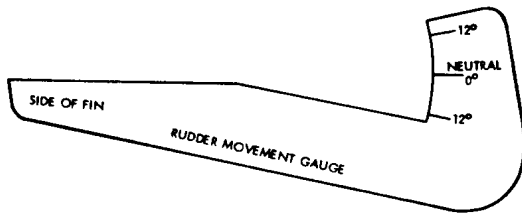

BALANCING & FLYING YOUR MODEL

TAKE THE TIME TO PROPERLY BALANCE YOUR MODEL AS SHOWN HERE!
THIS INFORMATION APPLIES TO ALL AIRPLANES

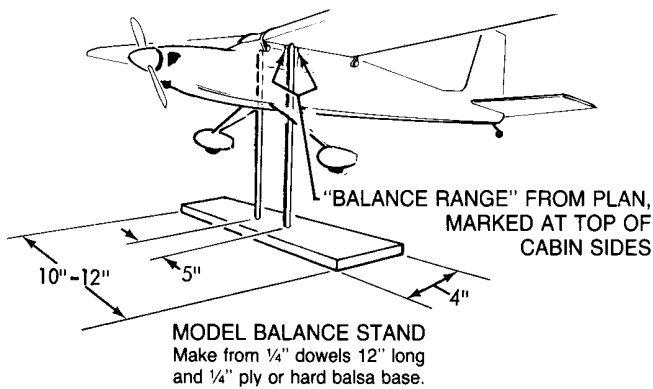

- Refer to plan side view and carefully measure and mark the "Center of Gravity" (CG) range on the fuse sides.
- Place motor battery in fuse—but DO NOT connect! With everything installed, mount the wing and carefully check the Center of Gravity. One way is to perch the model on the thumb and forefinger of your left hand (if you're right handed), while steadying the model with the other. A much better way is to use a set-up with a couple of pencils, spaced apart just enough to clear the fuse. Support the model in the CG range, until model is level. If you need to support the model outside the balance range to get it level, add weights to the extreme nose or tail as needed to achieve proper balance. Small self-adhesive weights made just for this purpose should be available at your dealer. The least weight is needed when added as far forward or back as possible. Fasten weight permanently in place.

DO NOT ATTEMPT to fly the model with the CG EVEN SLIGHTLY BEHIND the rearmost recommended position.

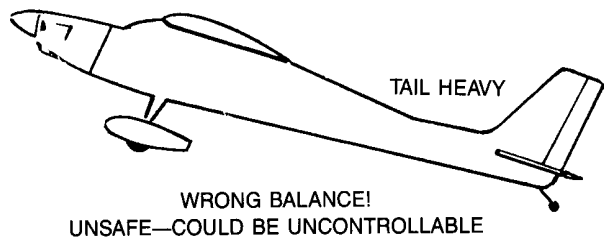
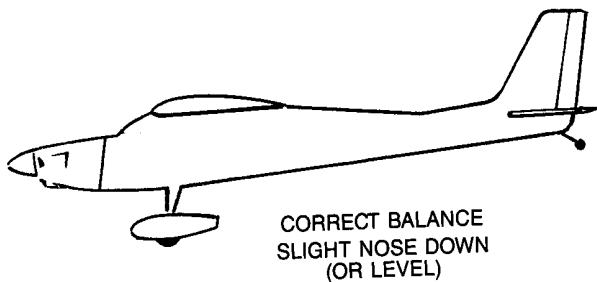

Don't be afraid to add whatever weight is necessary to balance your plane according to your needs.

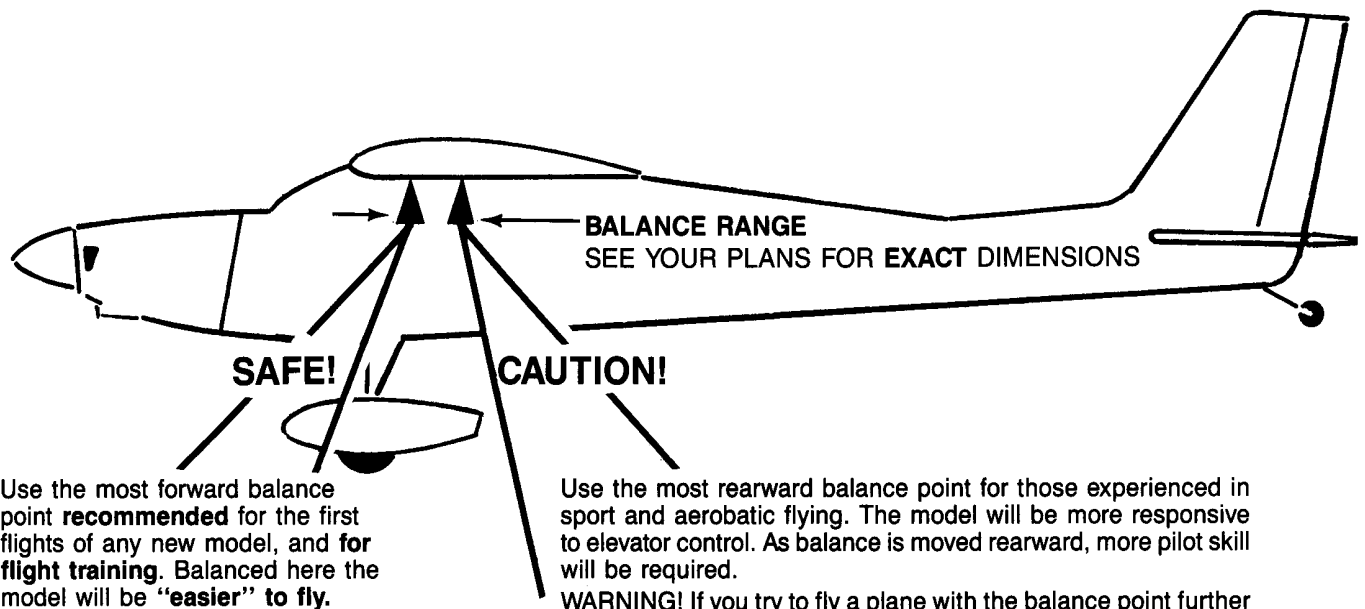

MOTOR AND BATTERY, MAINTENANCE AND CHARGING

Please take time to read this section very carefully. If you don't understand, read it again, this material is very important for both your safety and to obtain maximum performance from your Mirage.

The Turbo 550 motor is a special Mabuchi motor designed for electric plane use on 6-cell 1,200 MAH nicad battery packs. This battery is commonly used with the 1/10 scale "Off Road" electric cars and is readily available. You can also use 7-cell batteries and get a better climb rate but you also will have a shorter engine run and the motor will run hotter (see figure A).

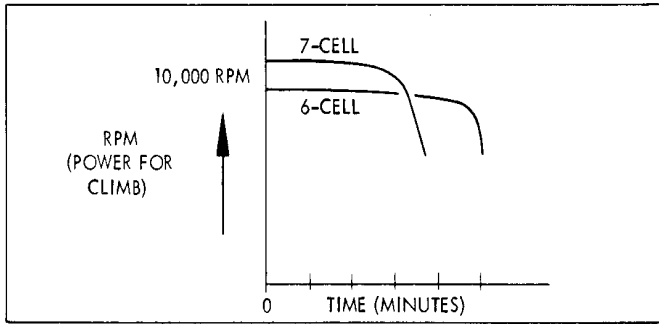

FIGURE "A"

MOTOR

The motor is ready-to-use, just install as shown ensuring there is enough ventilation for cooling. After a few flights you should notice a small increase in power as the motor breaks in. You may also want to experiment with other propellers but we recommend you stay in the 7-4 to 8-4 size range.

If your battery charger has a knob for adjusting power output, you can "break-in" your motor with the following method. Connect the motor directly to the charger and slowly increase the charger power until the motor is running smoothly but at slow speed (at low RPM, a propeller is not needed). This method lets the motor brushes "wear-in" better than at full power and gives the motor a little more performance.

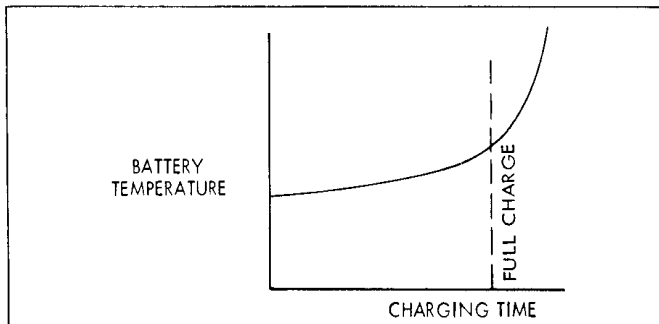

FIGURE "B"

BATTERY

This section is particularly important! One way to look at battery charging is to imagine the battery is a bucket and electricity is water. What you are trying to do is fill up the battery but not to overflow. At the very quick charge rate that is common with today's field chargers there is little room for error. When you overcharge, the temperature rises quickly and there is a potential of explosion or at least battery damage (see figure B). There are numerous ways to help prevent this, and HOW you can charge depends on the TYPE of charger you have. IMPORTANT! Always let the battery cool before charging!

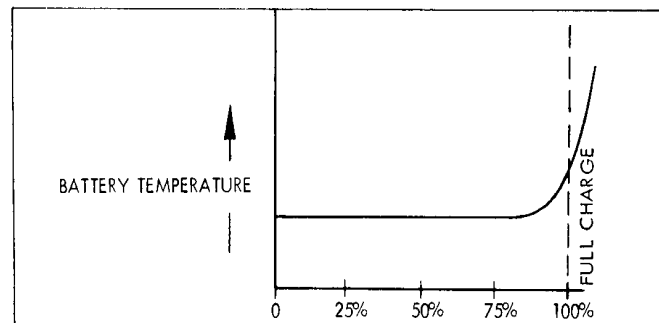

FIGURE "C"

TYPES OF CHARGERS

BASIC CHARGER WITH A TIMER

To prevent an overcharge you must know how "full" your battery is. If the battery is new or near empty, give it a full charge as per your chargers instructions, usually 15 minutes (at 4.5 AMPS if you have an ammeter).

During the last 5 minutes of charge, lightly touch the battery, if slightly warm that is OK. If too hot to touch—it is over charged—STOP CHARGING IMMEDIATELY! Let battery cool to room temperature before using, about 15-20 minutes. It is recommended you lightly touch to monitor the battery's temperature every 1-2 minutes during the last 5 minutes.

If you don't know how full your battery is, set your timer for no more than 5 minutes and monitor the temperature by lightly touching the battery every 1 or 2 minutes. When the temperature starts to rise, your battery is fully charged. Stop immediately (see figure C). Note: if you have a DIGITAL volt meter, it can be very

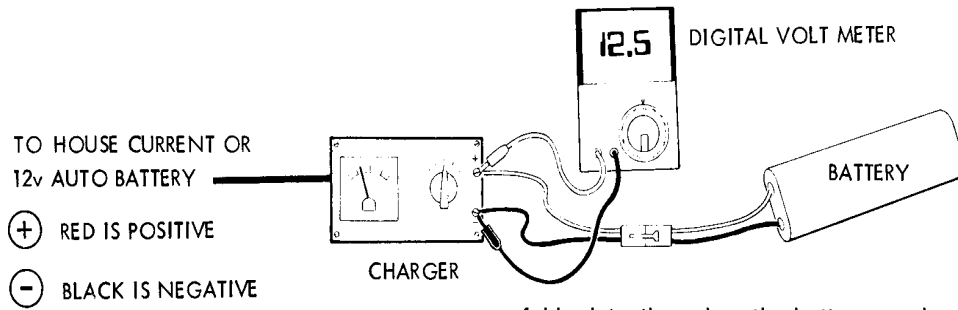

useful in detecting when the battery reaches full charge. As the battery fills, the voltage goes up. When it's fully charged, the voltage will stop rising and in a minute or two as the battery temperature rises the voltage will drop slightly. As soon as it drops, stop charging. This is an excellent way to get maximum battery performance (see figure D).

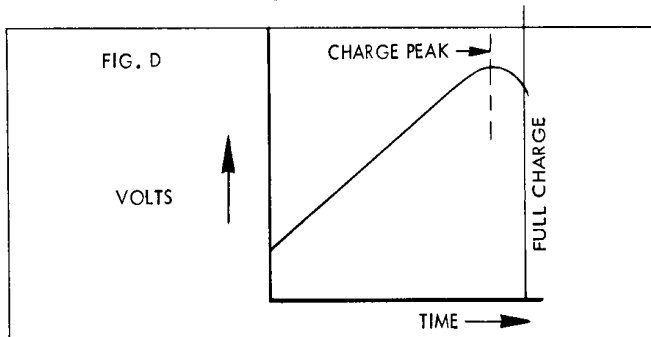

FIGURE "D"

AUTOMATIC CHARGERS

DELTA OR PEAK DETECTION CHARGERS. These are excellent methods of charging your battery. You simply connect and push a start button and wait. After approximately 15 minutes to ½ hour, disconnect the battery and it's ready to use. We still recommend you monitor temperature every 1-2 minutes after 10 minutes by lightly touching pack. If slightly warm—that's great, if too warm to hold—it is overcharging so STOP immediately! These chargers are more expensive but generally work very well.

TEMPERATURE SENSITIVE CHARGERS. Like the Peak detectors the thermal chargers work very well, but are more expensive. They also will charge a battery pack in 20 minutes or less and it doesn't matter how "full" the pack is when you start. Just follow the manufacturer's instructions carefully. This charger "senses" when the battery temperature signals full charge and automatically stops charging. Battery must be cool before charging or it will cut off prematurely.

EQUALIZING YOUR BATTERIES

Any battery that hasn't been used for a week or more should be equalized for best performance. To equalize the battery, charge for 10 to 20 minutes at the indicated rate, then trickle charge for three to four hours. Refer to your chargers instructions regarding trickle charge technique. Equalizing the battery will assure you top performance every time.

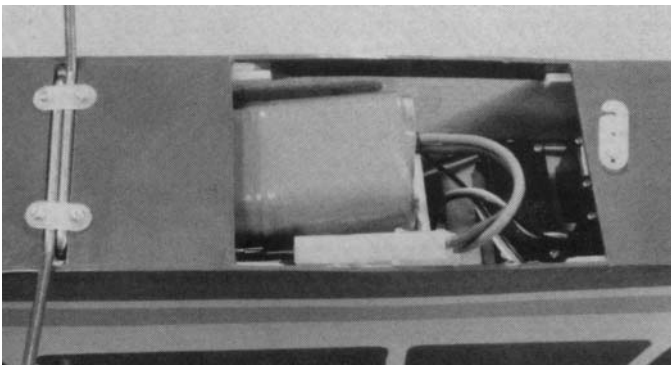

HOW MANY BATTERIES?

To get in the most flying each session we suggest you purchase three battery packs. While one pack is cooling and waiting to be charged, a second pack can be on charge and the third can be in your plane ready for use. Of course, you can fly with only one pack, but you may have to wait up to 40 minutes between flights.

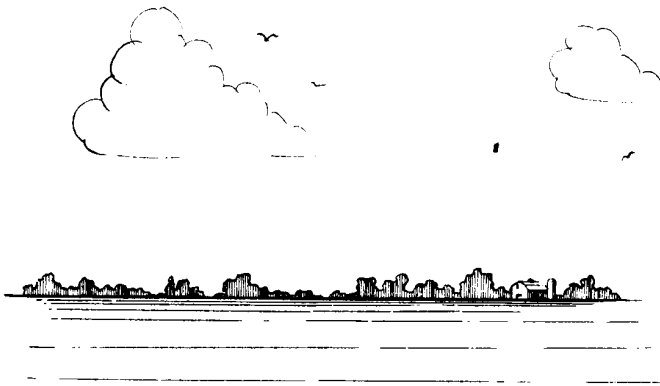

WHERE TO FLY

Fly only in areas sanctioned for R/C and known to be free of radio interference. Ask your hobby dealer or other modelers if there is an R/C flying field that is used by a local R/C club. This is the ideal place to fly. If you don't know of an R/C club nearby, contact the Academy of Model Aeronautics (AMA), at the address on the front of this booklet, for information on a club in your area. **Remember: R/C flying fields need to have rules to help prevent accidents, so ask about them before you turn on any of your equipment! DO NOT TEST your transmitter in the parking lot or anywhere nearby until you are sure no one else is using your radio frequency.** This could cause another flyer to crash and make you very unpopular!

If there is no club or other R/C flying site available, locate a square area (preferably a grassy field), at least **four or five football fields long**, which is free of power lines, trees, poles, houses, busy streets and other obstructions. It must be at least three miles away from any areas where other R/C models, such as boats or cars, are operated. It should also have a relatively smooth surface, as it will take practice to learn precision landings. If you find a suitable location, turn your receiver on for 2 or 3 minutes to check that no one in the vicinity is operating an R/C device which could affect your receiver and cause your plane to crash.

LEARNING TO FLY

Your chances of success are enormously increased if you have an instructor. Learning to fly is harder than it looks, and a mistake can seriously damage or destroy your model. Even full-scale pilots have problems learning to fly models because it's different—they're not in the cockpit. It's worth real effort to find someone to teach you. Many clubs have authorized instructors and there are even some R/C flight schools. Ask your dealer, or even check on the internet to see if there is someone who can help. **Only if there is no other way should you attempt to learn on your own.**

PRE-FLIGHT CHECK LIST, THINGS TO DO, AND THINGS TO TAKE TO THE FIELD

- Flight batteries fresh or fully charged
- Battery charger
- Extra motor batteries
- Radio transmitter (DON'T LEAVE IT AT HOME!)
- Tools to tighten anything that can vibrate loose
- Extra #64 rubber bands
- Extra props
- SUPER JET

CHECK YOUR EQUIPMENT!

Prior to going to the flying field, with radio batteries fully charged, turn on both receiver (Rx) and transmitter (Tx) and actuate all controls many times until you are satisfied with all functions.

Before beginning each day's flying, make a range check of your equipment in accordance with the manufacturer's instructions. In general, with transmitter antenna collapsed to 6"-8", you should have an at least 100 foot range on the ground. To check this, turn on both the transmitter and the receiver switches, set the model heading away from you, and walk away while transmitting signals. Watch to see that no signals are missed until you are at least 100 feet away. Only if the equipment works perfectly should any flights be attempted. Again, **be careful to not use your transmitter when anyone else at the field is flying or testing on the same frequency!**

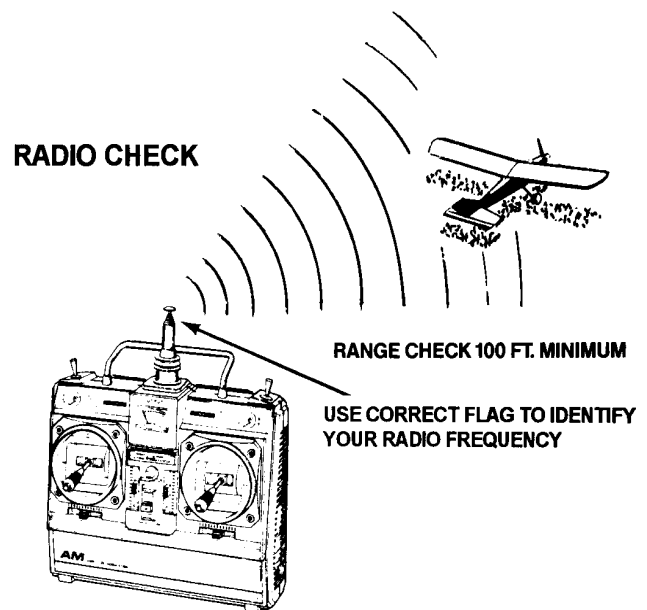

After the range check, stand behind the model and make sure the control responses are correct. Moving the control stick to the right should give right rudder. Moving the stick back or down on the Tx should move the elevator up, and vice versa. Check also to see that your motor turns on when the stick or tab is moved forward or up. Finally, make sure that everything on your aircraft is neatly and firmly in place—motor fastened down, servos snugged down, receiver and battery secure, antenna wire outside, etc. Use at least four #64 rubber bands on each side of the wing to make sure it is secure. Nothing should be loose, or unfinished, or unchecked. Finally, start the motor and run it several times. Make sure the control surfaces do not jitter or move until you command them.

The motor also should respond to your 3rd-channel command. We recommend you use 3 channels so that you can cut power and land whenever you want. On your first few flights, you may want to land and relax after a couple of minutes, but if you have only a 2-channel set-up (without motor control), you must keep flying until battery power runs down.

FIRST FLIGHT

There is no way to fully explain the principals of flight and the techniques of flying in a few pages. Entire books have been written about apparently simple subjects, such as the shape of the wing. Furthermore, there is no substitute for an experienced R/C flight instructor. The following information is not intended to replace your instructor, but to help give you understanding of basic flight concepts and techniques.

The Mirage can be "hand launched" or allowed to take off from the ground. When taking off from the ground, very short grass or a paved runway is best. However, a grass take-off will use up some batter power that is better spent flying, and you run the risk of catching a wheel, flipping your plane and possibly damaging it. Also, if the prop strikes the ground, the fuse will blow and need to be replaced. For these reasons, hand launching is best for first flights.

MAKE GENTLE CLIMB OUT—5° TO 10°

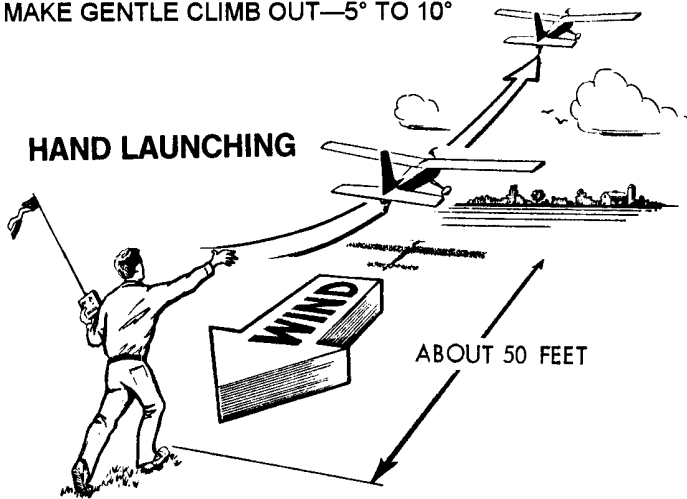

Hand launching is easy, but be careful, to avoid damaging the model. It is best to launch over some tall grass. Facing **INTO THE WIND**, hold the transmitter in one hand and the model, raised above your head, in the other. The wing should be level and the nose pointing straight ahead—not slightly up. Now, running slowly, launch the model and immediately take the Tx in both hands. As you launch the model, imagine that you are gliding it towards a spot about 50 feet ahead. **DO NOT THROW THE MODEL UP.** This is a natural tendency, but it will make the model stall (fall) and dive to the ground.

Remembering to **operate the controls smoothly**, add slight back stick pressure, if necessary, to keep the model from descending. When it is about 100 feet away from you, it will start to gently climb. Be patient; let it climb slowly, as a steep climb will cause it to stall. Most crashes are due to moving the controls too much, so be slow and gentle on the controls during "climb out" and throughout the flight. Overcontrolling tends to throw the plane out of control and wastes power. Just keep the model flying into the wind with wings level until you have reach an altitude of about 150 feet.



You can expect a solid 4 or 5-minutes of powered flight from a properly-charged battery. In this amount of time, Mirage will gain several hundred feet of altitude, allowing you time to get oriented and accustomed to control "feel."

When the plane is pointing at you, the steering will seem "reversed." When you give right rudder, the plane turns to your left—but the model actually is turning to its right. With practice, you will become accustomed to this. When the model comes toward you, simply push the stick left or right, in whichever direction the ship is turning. Another helpful technique is shown in Sketch A. "Head-on disorientation" is dangerous in the air, where things can happen pretty quickly. Before flying, it is wise to spend some time familiarizing yourself with orientation by operating the controls, with the plane set on a table, while you view it from different positions.



Sketch A



WHILE LEARNING TO FLY, YOU MAY FEEL BETTER ABLE TO CONTROL THE MODEL, AS IT COMES TOWARD YOU, BY LOOKING OVER YOUR SHOULDER AND FACING YOUR BODY IN THE SAME DIRECTION AS THE MODEL IS FLYING.



FLYING A PATTERN

At most flying fields, models fly in a rectangular path around the runway. This is called the "pattern." The most important reason for flying the pattern is that, as the model flies in different directions in the wind, the pilot will be better prepared for landing conditions when the flight ends. Full-scale aircraft fly a landing pattern for this same reason. Another important reason for flying the pattern is to organize the take-off and landing traffic, reducing confusion. The "traffic" pattern consists of **PATTERN ENTRY, DOWNWIND LEG, BASE LEG, AND FINAL APPROACH & LANDING.**

When you have reached an altitude of 150-200 feet, add just a touch of left or right stick until the model begins a very shallow turn. Try to maintain this shallow turn, keeping it gentle, and not tilting (banking) the wings very much. If you increase the bank, making the turn steeper, there will be a corresponding weight increase and reduction of lift. Therefore, your plane will start to descend. To maintain altitude in a turn, you will have to add enough back stick (up elevator) to hold the nose up through the turn.

TRY TO KEEP TURNS GENTLE ,

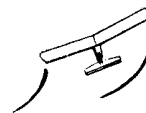

STEEP TURNS SHOULD BE AVOIDED

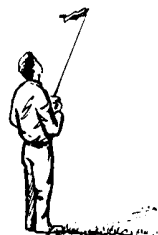

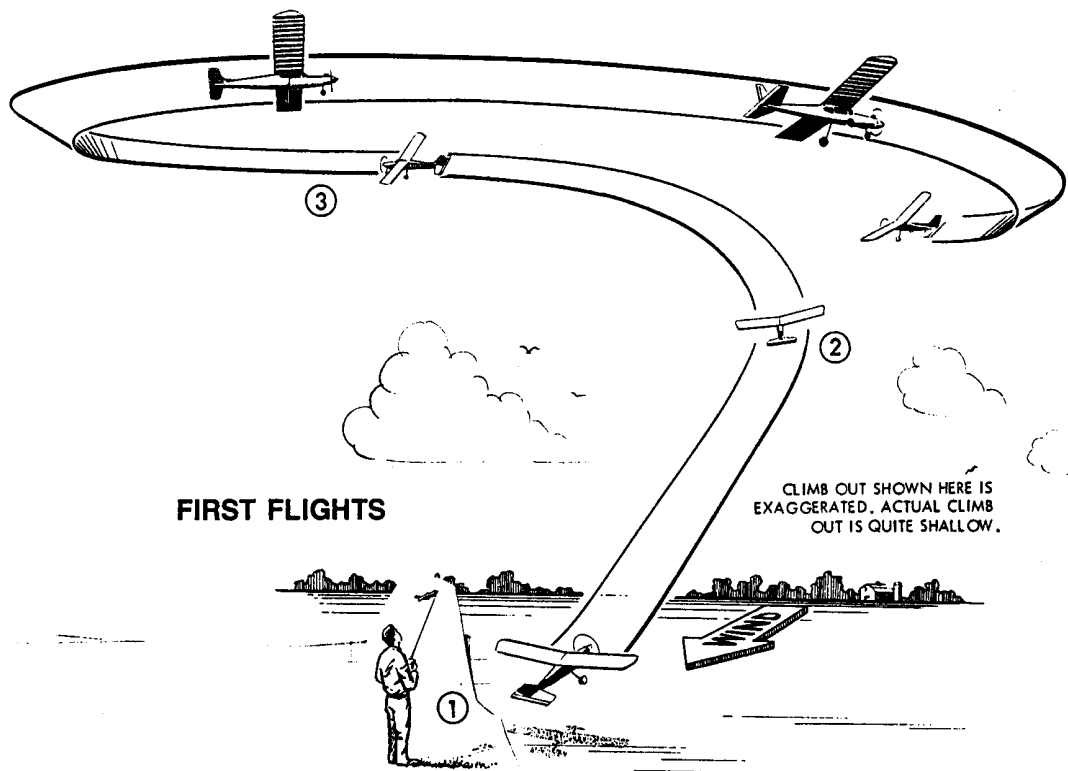

FIRST FLIGHTS

CLIMB OUT SHOWN HERE IS EXAGGERATED. ACTUAL CLIMB OUT IS QUITE SHALLOW.

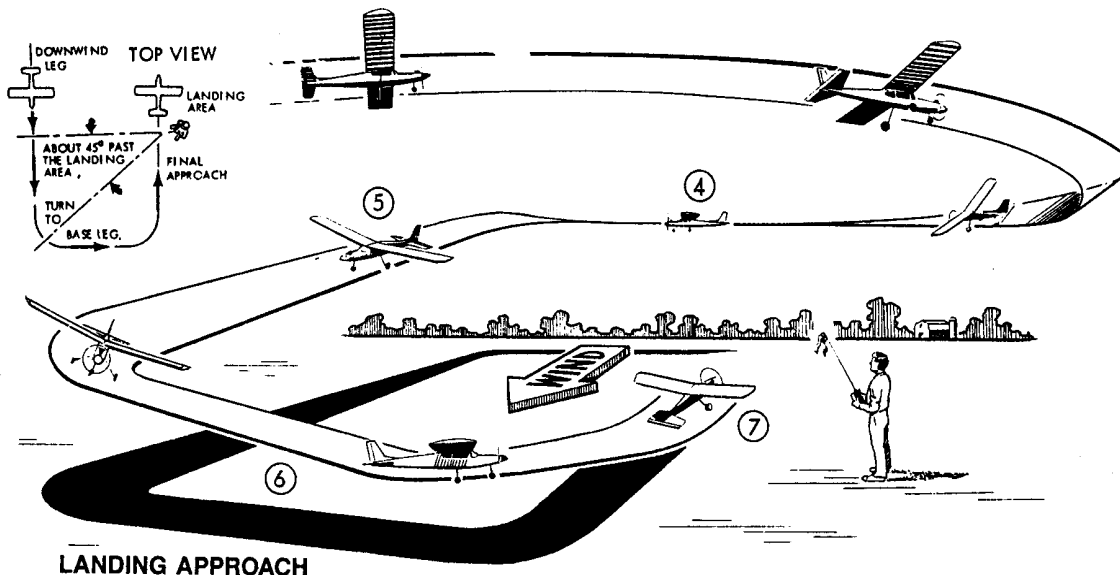

LANDING APPROACH

Plan to enter the pattern upwind at about 150 feet altitude. Make the Downwind Leg far enough away to allow for gentle turns to Base Leg and Final Approach. Avoid tight "panic" turns, particularly when landing.

The wind will tend to blow your plane and pattern further downwind. Try to keep it flying upwind at all times prior to your landing approach. It is more difficult to fly a model when it is downwind, and if a mistake is made, the model will end up even further away, making it more difficult to fly back to the field. To compensate for wind, continue making your upwind turns shallow, but make your downwind (with the wind) turns a little steeper.

LANDING

For your first landings, don't be concerned about trying to land in a particular spot. Just land safely, without damage to your model. At first, concentrate on flying in wide circles, as shown, and then simply glide down straight into the wind.

With a 2-channel system, when the battery begins to run out, the model will start a gradual descent. Continue circling and start calculating how much longer the model will glide. After imagining how much glide you have, you can start planning ahead for landing.

For 3-channels, if you have a helper, he can time your flight and tell when you have about four minutes of flight time. If you turn the motor off at that point, there will be one or two minutes of battery power left.

With the power off and the plane gliding downward, plan your approach for landing. When the model is about 45° downwind of the landing area, turn to Base Leg. Continue your descent, letting the model slowly lose more altitude. (If you are not happy with the approach, turn the power back on, climb out, and set up for another pass.) Remember, "a good approach is a good landing." Don't rush it.

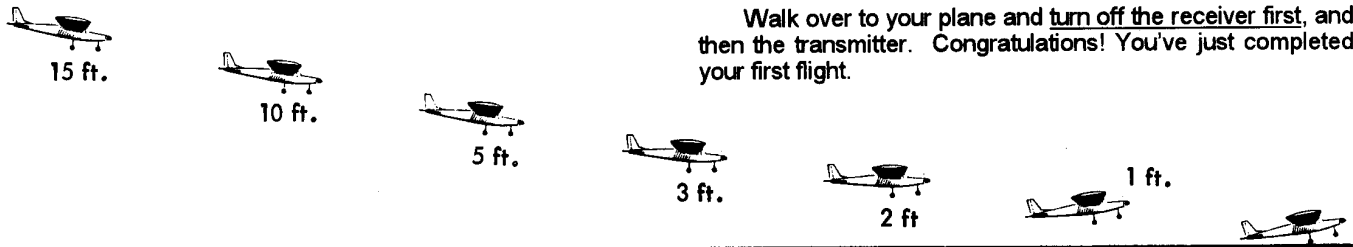

For your FINAL APPROACH & LANDING, make a gentle turn to point the model in the direction of the landing area. Keep the nose of the plane slightly down, so you don't stall. Steer the plane into the wind as it glides, keeping the wing level. Let the model settle in toward the ground and land. Just before the model touches down, you can add just a bit of back stick (up elevator) to "flare" and soften the landing.

Walk over to your plane and turn off the receiver first, and then the transmitter. Congratulations! You've just completed your first flight.

SETTING ADJUSTMENTS

As you get used to the controls, you probably will notice the model turning somewhat, or climbing or descending, without any stick pressure on your part. These tendencies can be corrected in the air by moving the trim tabs on the Tx. After landing, the setting of the rudder or elevator should be similarly adjusted as best you can by means of the clevises. This, in turn, permits the Tx trim tabs to be re-centered. Further flights will show if more adjustment is required. A severely out-of-trim condition (caused by a warped wing, for example) might not be correctable using the above trim techniques. In that case, taking the model home and straightening the warp with heat is necessary.

GROUND TAKE-OFFS

As you gain flying experience and confidence, you will want to try to take off from the grass or runway. First, point the model directly into the wind. Switch the motor on and gently steer the model straight with rudder as the model gains speed rapidly. After it rolls about 50-75 feet, add slight back stick (up elevator) pressure, so that the model rises smoothly from the ground. Only hold as much back stick as necessary to keep the plane in a 5° to 10° gentle climb. If you try to pull the model up too steeply, it may slow down and then stall and crash.

OVERSTRESSING THE AIRFRAME. Even world class aerobatic competition planes can be overstressed. The Mirage is very strong but can be broken in flight by over-speeding and then jerking the controls. If you find yourself in a steep high-speed dive, immediately switch motor off, level the wings and gently pull the stick back (add up elevator) to recover.

DANGER—SPIRALS, STALLS, OVERSTRESSING

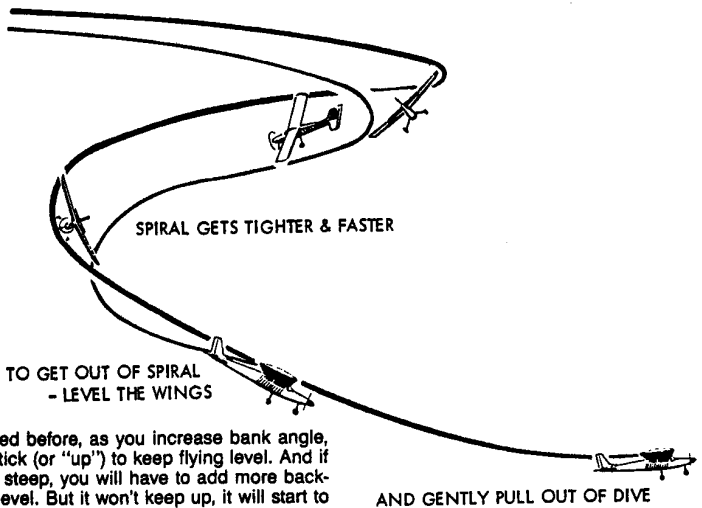

SPIRALS. As explained before, as you increase bank angle, you have to add back-stick (or "up") to keep flying level. And if you make the bank too steep, you will have to add more back-stick to hold the plane level. But it won't keep up, it will start to spiral downward—increasing its speed. Trying to "pull" the model out of the spiral by pulling back on the elevator only makes things worse! This sequence of events happens fast and can panic new flyers to the point that they fly the model right into the ground!

TO GET OUT OF THE SPIRAL—1st LEVEL THE WINGS!, then 2nd, pull it smoothly out of the dive.

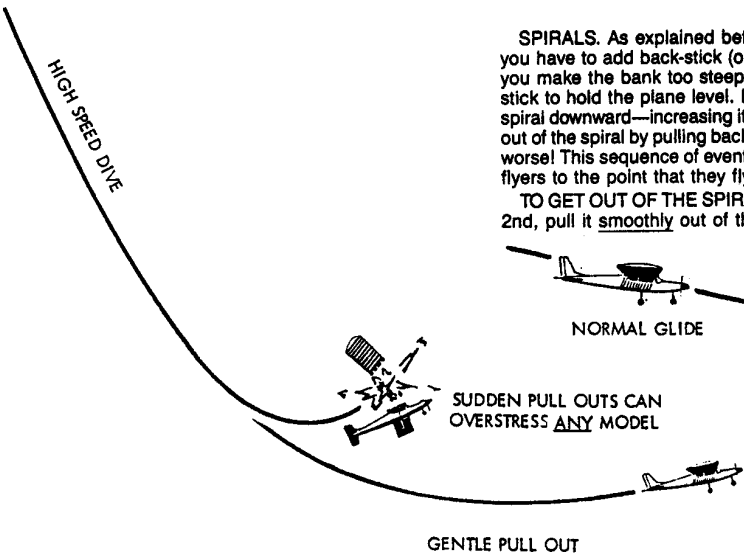

STALLS. Your model's movement through the air keeps it flying. If you fly too slow, there is a point where it will stop flying and fall out of the sky. This is called a stall. The Mirage has very gentle stall characteristics. However, when landing, be careful not to slow down too much.