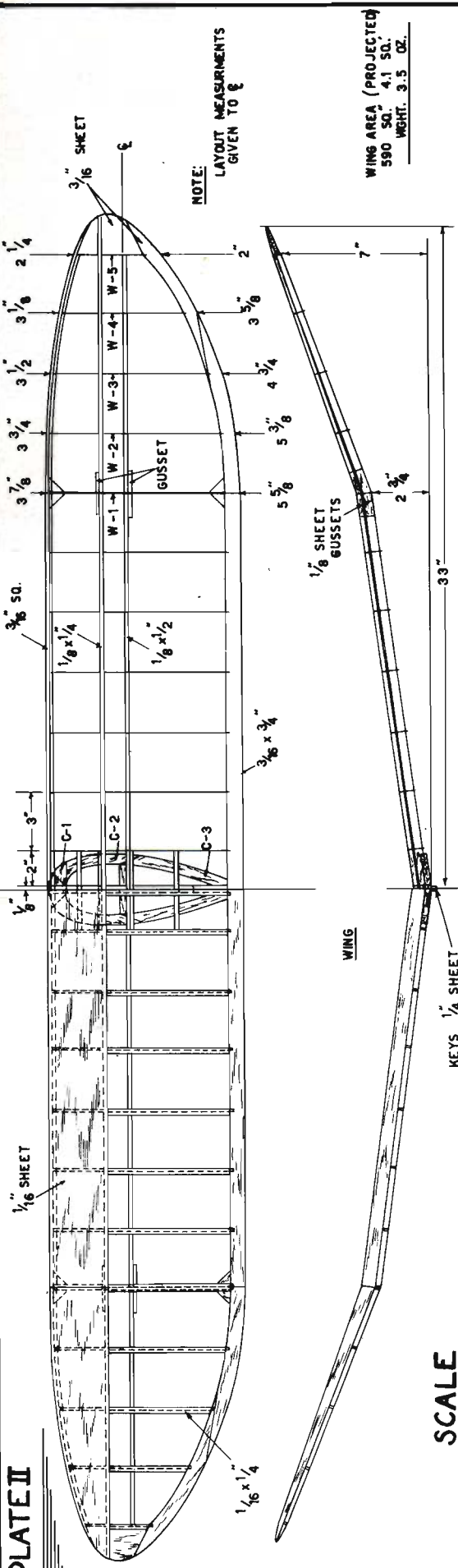
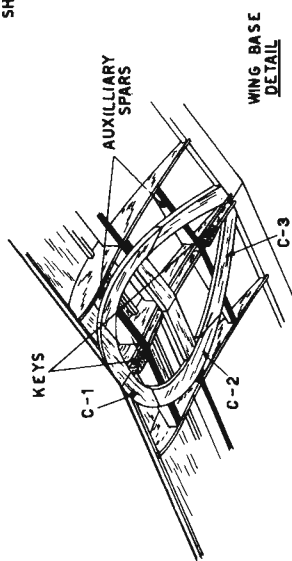
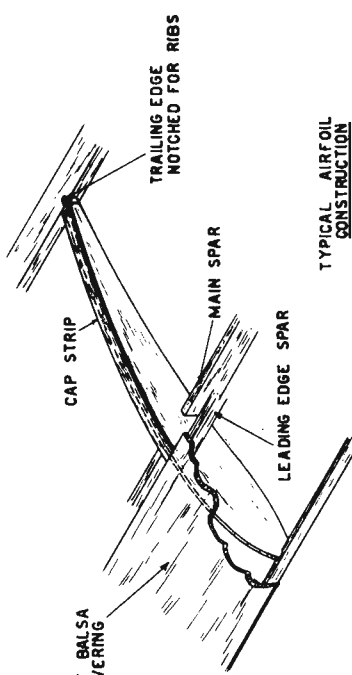
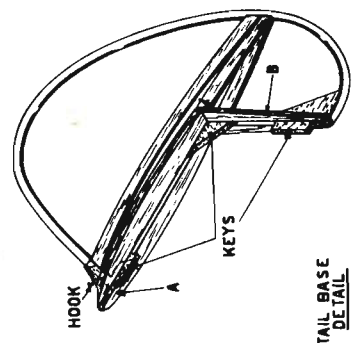

PLATE II



SCALE
1/8" = 1"



TAIL ASSEMBLY
WGHT. 2 OZ.
STABILIZER AREA
200 SQ.
RUDDER AREA
45 SQ.

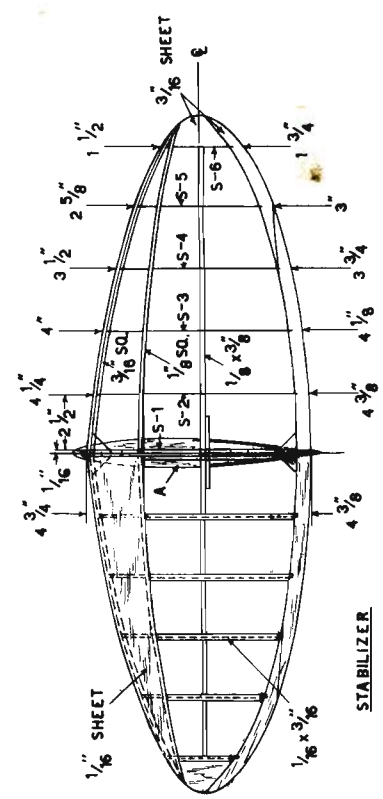

Brook

The K.G. LIVES AGAIN

How You Can Build a Modern Streamline Version of the Old Record-Breaking K. G. In Which Are Combined Super Soaring Qualities and a Skyrocket Climb

By HENRY STRUCK

PART 1



REGARDLESS of what the rules are, or will be, the basis of a winning design is stability. Probably the first model to be designed primarily for stability was the original K-G built in 1934 by Joe Kovel from complete designs and plans developed by Charles H. Grant. The success of this ship did much to popularize the sport of gas model flying.

Though it was a miniature airplane rather than a model, its size and weight were no great handicap, for under a 1/8 ounce per pound fuel rule it set a world's record of 1 hour, 4 minutes, which it still holds today under this fuel allowance rule. Slowly the K-G passed from the contest picture as the trend of design moved toward smaller, more powerful ships.

The high speed of the modern model planes puts even greater stress on the principles of stability.

What could be more logical then, than to revise the construction of the old K-G to meet the specific demands of present day contest flying? Though the new ship scarcely resembles the K-G in outward appearance, a brief examination of the three-view assembly plan will reveal that the arrangement of aerodynamic forces is identical. Every effort has been made to achieve maximum duration through effective streamlining and minimum weight, and many desirable features have been incorporated in its construction. The all balsa fuselage can be doped or varnished to resist the ravages of gas and oil and the rough handling a gas model is bound to get. The wing and tail construction offer great strength with light weight. The ship can be dismantled and reassembled with exactly the same settings by a number of "keys." The entire motor unit can be quickly removed for checking and servicing.

From its initial test the new ship performed up to all expectations. In fact in its first contest the K-G-S made the longest flight of the day, 4 minutes, 38 seconds, on a 17-second motor run, in spite of a scarcity of thermals, and also turned in the best three flight average.

Even more conclusive are the innumerable tests that have been made to discover its reactions under maladjustments. Left-

or right-thrust merely altered the power circle, while up-thrust caused it to hang on the prop while climbing. Only slight adjustments of the rudder were needed to obtain any size gliding circle desired. So, we are happy to present the K-G-S;

stable, strong, efficient and controllable—an ideal high-power contest gas model.

Construction Notes and Material List

The plans have been carefully prepared with all essential parts shown full size

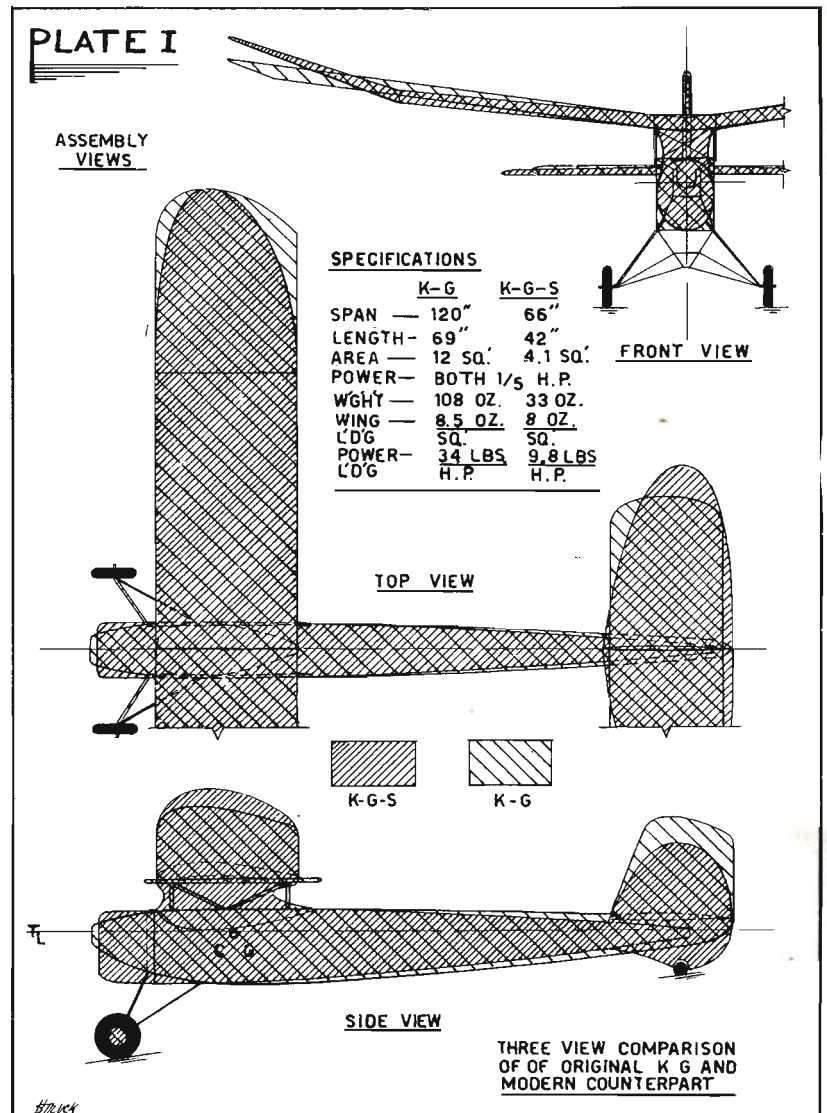
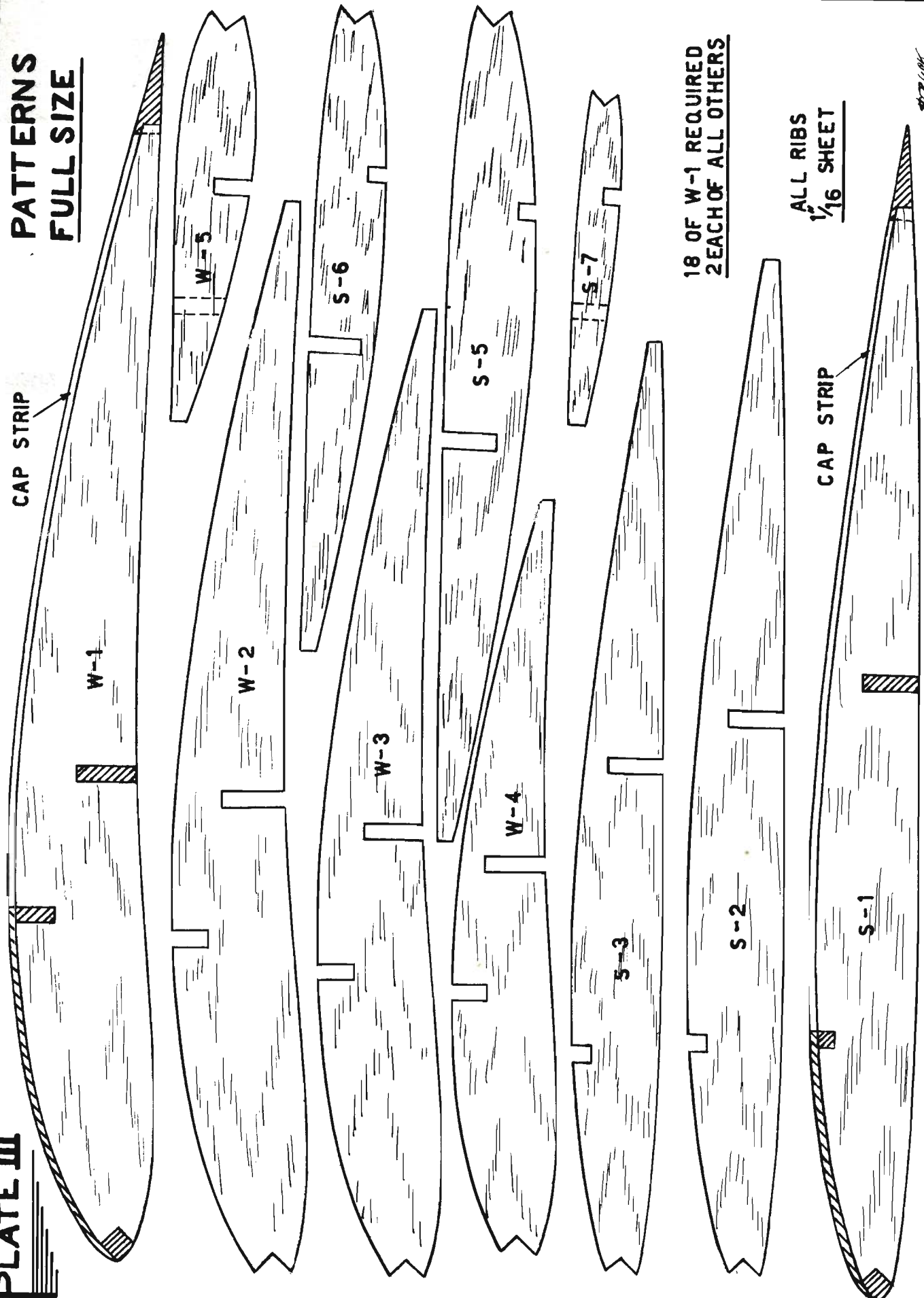

PLATE III

**PATTERNS
FULL SIZE**



**18 OF W-1 REQUIRED
2 EACH OF ALL OTHERS**

**ALL RIBS
1/16 SHEET**

BRUCE

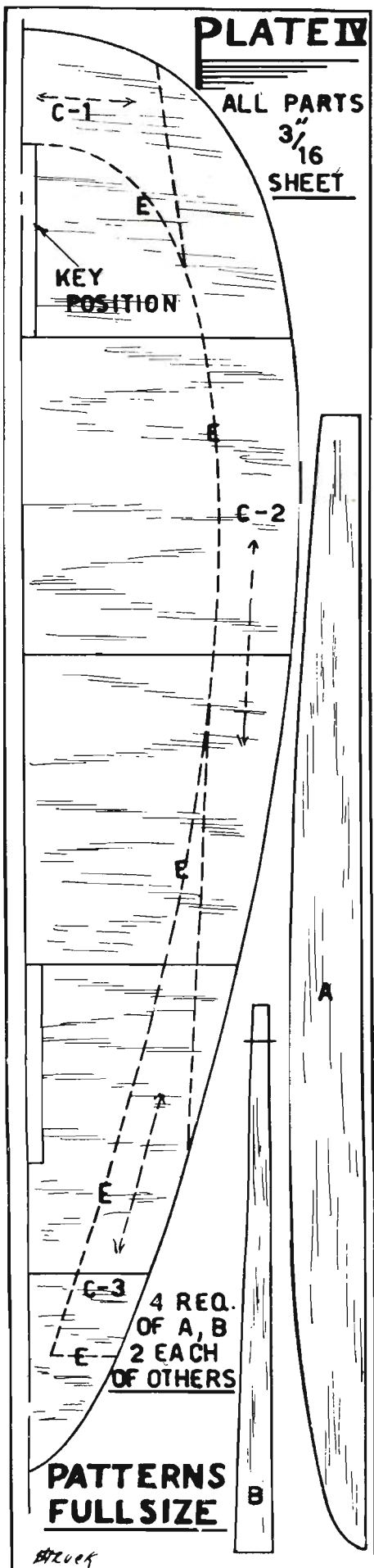

and illustrated with numerous sketches. In Part I the wings and tail assembly are to be described in the hope that a proper amount of time will be spent on them. Many builders in their rush to get out and fly their new model produce "butchered" or warped units that are often the cause of disastrous crack-ups.

Obtain the best possible balsa of the grade specified, as it will not only assure a better model, but prove a pleasure to work with.

Material List for K-G-S

- (4) 1/16x 2x36—Soft balsa
Stabilizer leading edge cover, ribs.
- (2) 1/16x 3x36—Med. balsa
Wing leading edge cover.
- (8) 1/8x 2x36—Soft balsa
Bulkheads, planking.
- (2) 3/16x 2x36—Med. balsa
Trailing edges of tips, fillets and pylon formers.
- (5) 1/8 sq. x 36—Med. balsa
Inner frame of fuselage.
- (3) 3/16 sq. x 36—Med. balsa
Leading edges.
- (4) 1/16x1/4x36—Soft balsa
Cap strips.
- (3) 1/8x1/4x36—Hard balsa
Leading edge spars.
- (3) 1/8x1/2x36—Hard balsa
Mainspars.
- (2) 3/16x3/4x20—Med. balsa
Trailing edge.
- (1) 6x4, 1/16" plywood
Front bulkhead.
- (1) 3x3, 1/8" plywood
Motor bulkhead.
- 24"—1/8 wire
Landing gear.
- 12 sheets tissue
Covering.
- 1/4-yard silk
Fillet covering.
- 3x5,—.040 alum.
Motor bearers.
- (5) 3/32"x3/4 bolts
Motor mount assembly.
- 12"—.028 & .040 wire
Wing and tail hooks.
- (2) bicycle spokes
Motor retainers.
- 24"—1/4 alum. tubing
Rudder outline.
- 1 pt. cement and 1 pt. clear dope.

Wing and Tail Construction

As the construction of the wing and stabilizer is identical, they will be described together. From the 1/8" to 1" drawings given on Plate II make full size layouts on which to build. The distances from the leading and trailing edges to the center line are given for each rib station. Connect these points guided by a strip of balsa held in place with pins or drawing curves.

Trace the shape of the trailing edges and tips from your layout onto 3/16" medium sheet balsa. Cement the sections together and shape to a triangular cross section with knife and sandpaper. Cut 1/16" deep notches in the trailing edges to receive the ribs.

Pin the trailing edges and the 3/16" square leading edges on the layout.

The ribs are shown in full size on Plate III from which they may be transferred to 1/16" sheet balsa. A metal or cardboard template may be made of the main wing ribs to speed up cutting them out. Cement the ribs in place, so that the top of each rib is 1/16" below the top of the trailing edge, to leave a recess in which the cap strips are later fitted.

Remove the wing frame from the layout and rejoin the panels at the correct dihedral, reinforcing the corners with gussets of 1/8" sheet. Insert the leading edge spars of 1/8" x 1/4" and the main spars of 1/8" x 1/2" hard balsa. The main spars have to be tapered to 1/8" x 3/8" at the tips, in the wing and to 1/8" x 1/4" in the

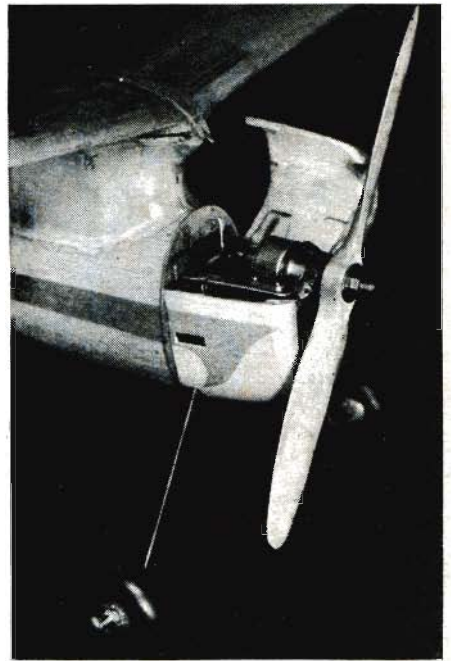

The engine cowl cover folds back allowing access to the engine unit

stabilizer. Gussets of 1/8" sheet are used to reinforce the joints.

Apply cement liberally to the leading edge and pin the 1/16" sheet balsa covering to it. Bend the sheet over the ribs, moistening the upper surface slightly to facilitate bending, and glue the balsa to every rib and the leading edge spar. Cover one panel at a time, correcting any tendency to warp, before the cement has set solidly. Fit the cap strips in place using double width strips over the center ribs. Trim excess balsa from the leading edges and smooth the framework with successively finer grades of sandpaper. (See typical airfoil construction, Plate II.)

On Plate IV the wing and tail base patterns are given in full size. Parts E and the extra pairs of A and B form the wing and tail rests incorporated in the fuselage. Next step is to set a pair of auxiliary spars of 1/8" sheet in the center section. Cement the wing base outline composed of C-1, 2 and 3 in place, notching the noses of the center ribs and the auxiliary spars so that the top of the wing base may be cemented to the bottom corner of the leading edge. At the rear, the bottom of the wing base is flush with the bottom of the trailing edge. When dry, sand the surface of the wing base perfectly flat and insert the keys of 1/4" sheet balsa between the center ribs. (See wing base detail, Plate II.)

Cement the tail base A to the sides of the stabilizer center ribs. B is part of the rudder structure and is attached after the stabilizer is covered.

Covering and Rudder

Red double-tissue covering was used on the original. Though it requires going through the motions of covering twice, it has proven lighter and stronger than bamboo paper and affords a neatly colored job without painting.

Use fresh tissue to speed up work and protect against wrinkles. The first coat is applied with the grain running chord-

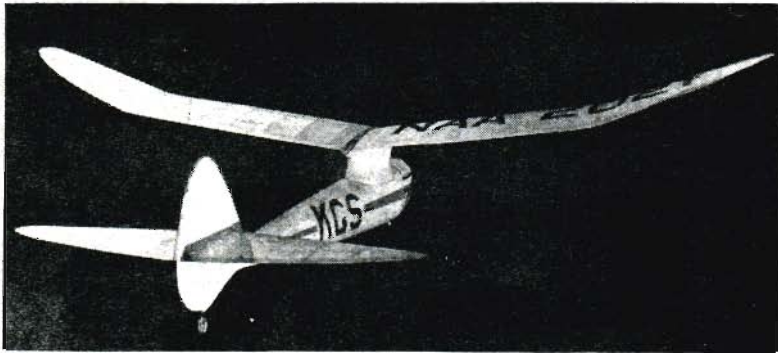

It embodies the same stable arrangement as its big brother K.G.

wise. Cover the bottom of the wing first, being careful to dope the tissue to the bottom of every rib to preserve the air-foil section. Elsewhere it is necessary to dope the paper only to the edges of the frame. Any difficulty that may be encountered in covering around the wing or tail rests can be eliminated by wetting the troublesome spot and then the tissue will almost fall in place. Spray the covered surfaces with water and when dry apply the second coat of tissue with the grain running spanwise. Do not dope the first coat. Spray again with water and when dry brush on two coats of clear dope. Between each watering and doping operation correct any warping tendency by holding the frame in the proper position till dry.

The rudder outline is formed of 1/4" O.D. aluminum tubing. This type of rudder can be easily bent to any desired setting, but cannot be knocked out of ad-

justment or warped by weather conditions. Flatten about 1" of the tubing, bend it over and tuck it under the leading edge of the stabilizer. Mount the rudder post B in place and cement the outline to the bottom. Set the keys of 1/8" sheet between the stabilizer center ribs and in the bottom of the rudder post. Fill in the rudder with 1/16" sheet around the stabilizer, using the outline of the center rib as a pattern. Cover with double tissue and cement small mounting hooks of .028 piano wire in place. (See tail base detail, Plate II.)

Check the alignment of the tail assembly to be sure the rudder is square and not offset in either direction.

A list of various engines which may be used, with their displacement, the minimum possible or required weight of the model and the wing loading in ounces per square foot which will result, is shown in the column at the right.

| Engine | Displacement | Minimum Possible or Required Weight | Wing Loading in Oz. per Sq. Ft. |
|---|--------------|-------------------------------------|---------------------------------|
| *Ohlsson 23..... | 23 | 33 oz. | 8 |
| *Hi-Speed Torpedo..... | 30 | 33 oz. | 8 |
| The next 5 engines give the best results in Class C | | | |
| Baby Cyclone..... | 0.357 | 33 oz. | 8 |
| Mighty Midget..... | 0.45 | 36 oz. | 8.6 |
| Gwin-Aero | 0.45 | 36 oz. | 8.6 |
| Hurleman Aristocrat..... | 0.488 | 38 oz. | 9.1 |
| Sky Chief | 0.526 | 42 oz. | 10 |
| Dennymite | 0.57 | 46 oz. | 11 |
| Brown | 0.6 | 48 oz. | 11.3 |
| O. K. | 0.6 | 48 oz. | 11.3 |

*Using these engines, the K-G-S is eligible for Class B competition. With others it is eligible for Class C.

If the larger engines are to be used the required minimum weight can be made up easily by using large batteries and harder wood than specified in the plans.

With the limitation of available power, aerodynamic efficiency and stability have greater bearing on the minimum performance of a gas model. The K-G-S has these desirable qualities in full measure when equipped with any of the engines illustrated above, or those of equivalent displacement.

PART 2

Fuselage Construction

The fuselage is planked. This seems such a tedious and difficult task that we can almost feel the vibration of some of you shuddering. But with a proper system quite the reverse is true, while the advantages of a planked body are obvious. To those who remain unconvinced two other courses are open. One is to use sheet balsa, which has proven to us to be as difficult as planking without producing as smooth a job. The other is to substitute stringers. If about fifteen stringers of 1/8" x 1/4" hard balsa are spaced around the bulkheads a very nice fuselage can be built. After bulkhead F-9 six of the stringers may be stopped to avoid congestion at the rear. Sheet balsa should be fitted between the stringers from F-1 to F-3 and the fuselage covered with silk.

But every modeller should turn out at least one "masterpiece," and we are sure this ship will prove well worth the effort.

Lay out the inner frame plan in full size. The longerons are perfectly straight to simplify the task of turning out a true frame on which to assemble. Construct the bottom, or plan view, first and build the peak of the triangle on it while still pinned to the work bench. The side view gives the height of the top longeron above the bottom and not the true length of the

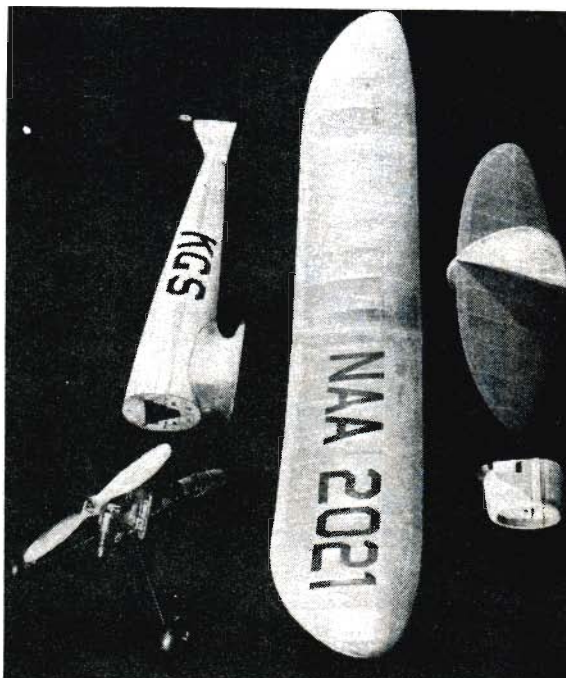

It is composed of structural units that may be assembled or taken apart quickly

struts. These must be fitted in place. (See step I, fuselage assembly detail, Plate V.)

Cut the bulkheads, given full size on Plate VI, from 1/8" sheet and slip them on the frame. Cement in place the 3/16" sheet pylon formers D-1 and 2, shown full size on Plate V. Lay a floor of 1/8" sheet and fill the space between F-3 and 4 with 1/16" sheet walls to form a rigid box. The top of the pylon E consists of a number of 3/16" sheet sections. The outline of these coincides with that of the wing base, which was given last month on Plate IV. Form a pair of "U" shaped hooks of .040 piano wire and anchor them to the pylon formers with several coats of cement. Stiffeners of 3/16" square and a diagonal in the front pylon section are fitted to prevent the taut covering from pulling down the edges.

Pin a number of planks in place and check the bulkheads for high spots that may cause bumps in the finished job. When any offending areas have been sanded down, cement the five main planks in place. (See step II, fuselage assembly detail, Plate V.)

(Continued on page 18)

PLATE VI

ALL
BULKHEADS
 $\frac{1}{8}$ SHEET

POSITION
PYLON
FLOOR

F-2
SHOWN BY
BROKEN
LINES

F-1
SHOWN BY
SOLID LINES,
 $\frac{1}{16}$ PLWOOD

PATTERNS
FULL SIZE

#TRUCK

SCALE EXCEPT
 $\frac{1}{4}'' = 1''$
 PATTERNS
 FULL SIZE

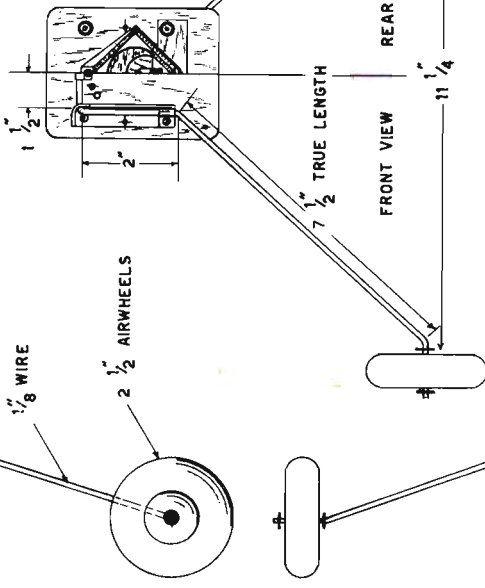
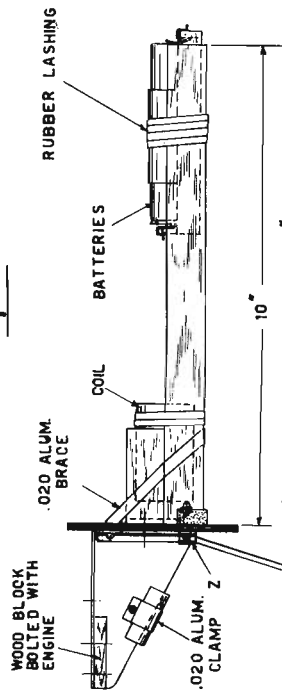

MOTOR UNIT
 WGT. BARE 4.5 OZ.
 INCLUDING BATT. COIL, ENGINE, 21 OZ

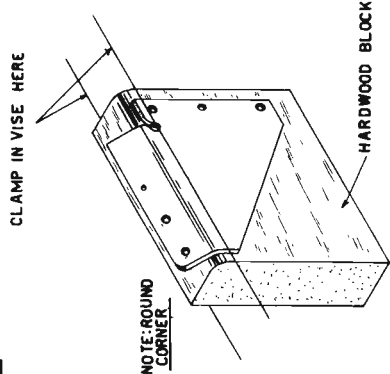
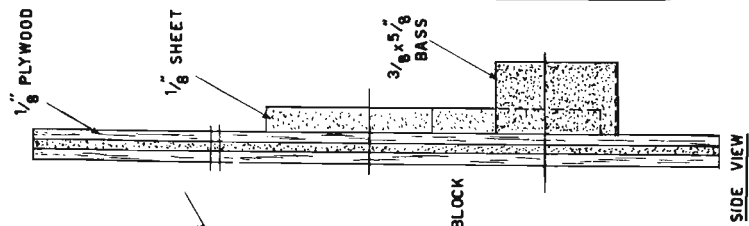
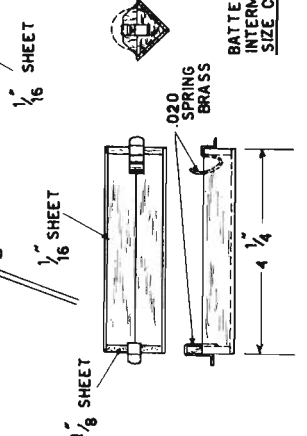

NOTE: ROUND CORNER

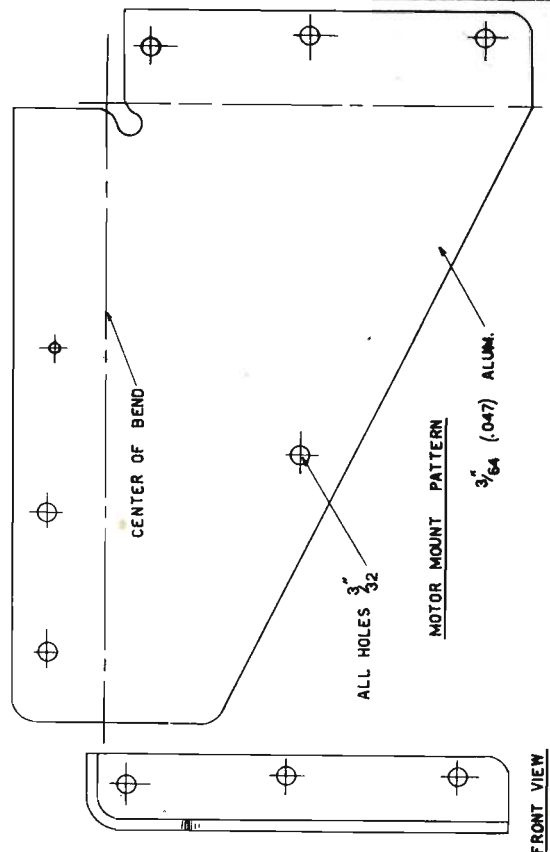
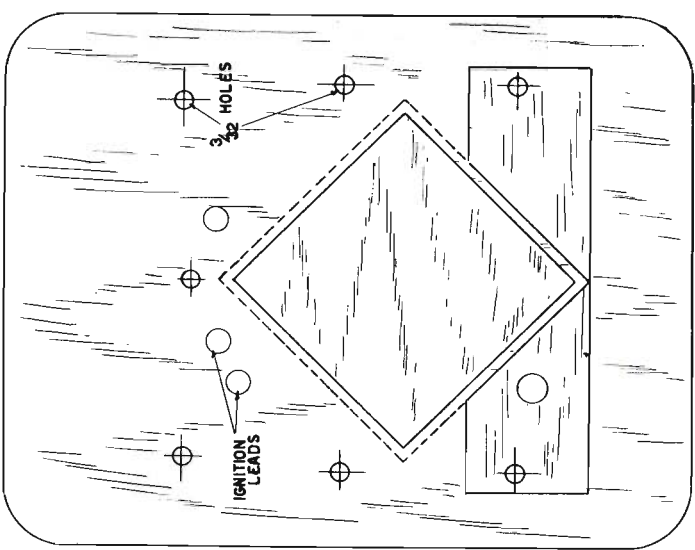

STREET

The K.G. Lives Again

(Continued from page 14)

Install the motor mount retainers formed of bicycle spokes, and reinforce the space between F-2 and 3 with a spreader of 1/4" sheet. (See motor mount retainer detail, Plate V.)

Continue planking the fuselage with 1/8" x 3/8" soft balsa strips. Fit each plank at the rear of the fuselage by holding it in place and marking accurately before cutting the taper. (See fitting planks, Plate V.) Bevel one edge slightly with coarse sandpaper to take care of the sharp curve of the bottom of the bulkheads. Use plenty of cement and pin each plank tightly against its neighbor and there will be no apparent seams after the body has been sanded. Trim any overhanging planks flush with the face of F-2 and cement F-1 of 1/16" plywood in position.

Using a very sharp knife, carve the "squareness" and the cement skins from the surface. Hold the blade at a shallow angle and take only long thin "peelings." Then smooth the surface with coarse sandpaper and gradually use finer grades, finishing with 6-nought and polishing with 10-nought. Apply about four coats of clear dope, sanding with 10-nought between each. A good finishing method is to cover the fuselage with bands of tissue about 4" wide, applied with the grain running around the body. Sand and dope as before.

Cut an opening in the fuselage and mount the flight timer. The one illustrated was converted from an autoknips camera timer. The heavy case has been removed and a sheet of .010 brass substituted. Be sure it fits snugly at the bottom or the moving arm may disengage from the driving gear. However any other type timer may be installed with a little ingenuity and will work quite as well. Run two leads to a pair of "jacks" made from large face brass bushings mounted in F-1. (See timer conversion, Plate VIII.)

Cement the tail post B to the rear of the fuselage, so that the tail rest A will give the stabilizer negative incidence of 1/4" as compared to the top of the wing mount. These parts are the same as the tail base given on Plate IV last month. Cut the fin outline from 3/16" sheet and attach a small tail wheel by an .040 wire fork. Brace the tail base with short 1/8" x 3/8" uprights to prevent sagging when covered. Cement a narrow beading of 1/16" square to the fuselage, to set the edges of the tail base, fin and pylon fillets.

Now to cover the pylon with silk. This is a new trick that produces a beautiful job. First cut a section of silk of ample size and wet it thoroughly. (A) Immediately lay it in place, spreading it roughly into position. You will find the wet material sticks to the frame. (B) Now apply heavy dope over the silk in the area

between F-3 and 4. Pull it vertically taut using pins to hold it if necessary. (C) Then draw in each end, pulling lengthwise, doping and pinning the silk in place in a similar manner. When the water has evaporated apply two or three more coats of dope to prevent the silk from springing loose when the pins are removed and the surface doped. While doing this run a razor blade over the silk at the bottom, along the beading strip and refinish the planking with several coats of dope, sanding between each. The tail fairings are done in similar manner. Try to pull the silk as evenly as possible on each side to assure a symmetrical cross section. However if one side does have less "hollow" than the other, a band of extra coats of dope brushed on lengthwise will increase the curve. Avoid doping the silk to any of the pylon struts or formers, or the smoothness of the fillet will be spoiled. Do not be disturbed by small wrinkles as silk absorbs them amazingly when doped, and even jagged tears can be repaired by merely laying on a patch and doping several times. (See step III, fuselage assembly details, Plate V.)

Motor Unit

Cut the motor bulkhead, shown full size on Plate VII, from 1/8" plywood. Cement and brad a plug of 3/8" x 5/8" bass, which fits snugly into F-1, to the bulkhead. Glue the battery trough of 1/16" hard sheet balsa into the Vee-shaped notch in the center of the plug. A square of 1/8" sheet reinforces the joint. Short lengths of 1/16" sheet form a box in which the coil is housed. Use several coats of cement on all joints.

Trace the full size motor mount pattern onto 3/64" sheet aluminum and cut out with a jeweler's saw or tin snips. Clamp the blanks together in a vise and file them to exact shape. Bend the blanks to shape over a hardwood block, by tapping with a mallet, or a block of hardwood and a hammer. Be sure to make one left and one right. Drill all the holes with the exception of those for the motor. Cut three blanks of .020 sheet aluminum and bend fittings Z around 1/8" diameter wire. Form the landing gear of 1/8" diameter piano wire, measuring each bend to assure symmetry.

Slide the motor mounts and the fittings on the landing gear. Attach them to the bulkhead with 3/32" bolts. The top landing gear fitting bolt also holds a 3/8" wide brace strip of .020 sheet aluminum. This is bent down and glued to the bottom sides of the battery trough.

The battery box is a 1/16" sheet trough with ends of 1/8" sheet cemented solidly in place. Terminals of .020 sheet brass are fitted, one of which is formed into a spring to insure good contact. A pair of 2-1/2" wheels are retained on the axles by washers soldered on both sides.

Slip the motor unit into the fuselage and clamp it in place by tightening down a pair of bicycle spoke nipples on the

protruding bicycle spokes. An inverted Brown motor was used in the original but any other engine can be accommodated by drilling the mounting holes to suit the crankcase. Drill one hole and bolt the engine in place, checking carefully to make certain the thrust line is not offset. Then drill the remaining holes and complete mounting the motor.

Remove the motor unit and install the wiring. The ignition hook up recommended on Plate VIII will operate on the boosters while the timer switch is open, helping to conserve the small batteries.

Cowling

The cowl is planked on two formers, G-1 and 2, connected by four 3/16" square spacers. Add the nose piece of 1/2" balsa and round smoothly. Cut the cowl near the top and hinge the two parts. A small rubber band at the rear snaps the top shut after the engine has been adjusted. A pair of .028 piano wire clips attach the cowling to the motor mounts. (See Plate VIII.)

Before operating the engine apply a coat of spar varnish to the fuselage, cowl and motor unit to oil proof the structure.

Flying The K-G-S

Attach the tail unit with small rubber bands and slip the motor unit in place. Balance the model by sliding the batteries till the center of gravity is established 5" from the front of the pylon. Mount the wing with about six or eight strands of 1/4" rubber and proceed to get the "feel" of the ship by gliding it from low altitudes into tall grass or weeds if possible. Then find a more open area and make numerous glides to discover any circling tendency. Adjust the rudder to produce an almost straight glide, with possibly a slight curve to the right to avoid a long chase after the engine cuts.

When satisfied start the engine and get it running smoothly at about half speed. Set the timer for ten seconds. With such a short motor run it will be best to hand-launch the ship if no smooth take-off spot is available. Even under this power the K-G-S will climb swiftly and demonstrate its glide. Of course finer adjustments will be needed. The only way to find them is to fly the ship as often as possible. Adjust the model to make circles of about 150 to 200 feet while gliding by bending the rudder; increasing the negative incidence of the stabilizer if the glide seems a bit steep. Under power the best climb, without a dip at the top as the engine cuts, is obtained by right circles slightly larger than those of the glide. The power flight can be easily adjusted by placing thin wedges between the motor bulkhead and the fuselage face to offset the thrust line.

Though your ship may lead you a merry chase under even half-power, you can be sure of it when you give the timer the full run of twenty seconds and open the engine wide. The K-G has come back,— "and how!"

PLATE VIII

G-3 SHOWN BY
SOLID LINES,
1/2 SHEET, OTHERS 1/8 SHEET

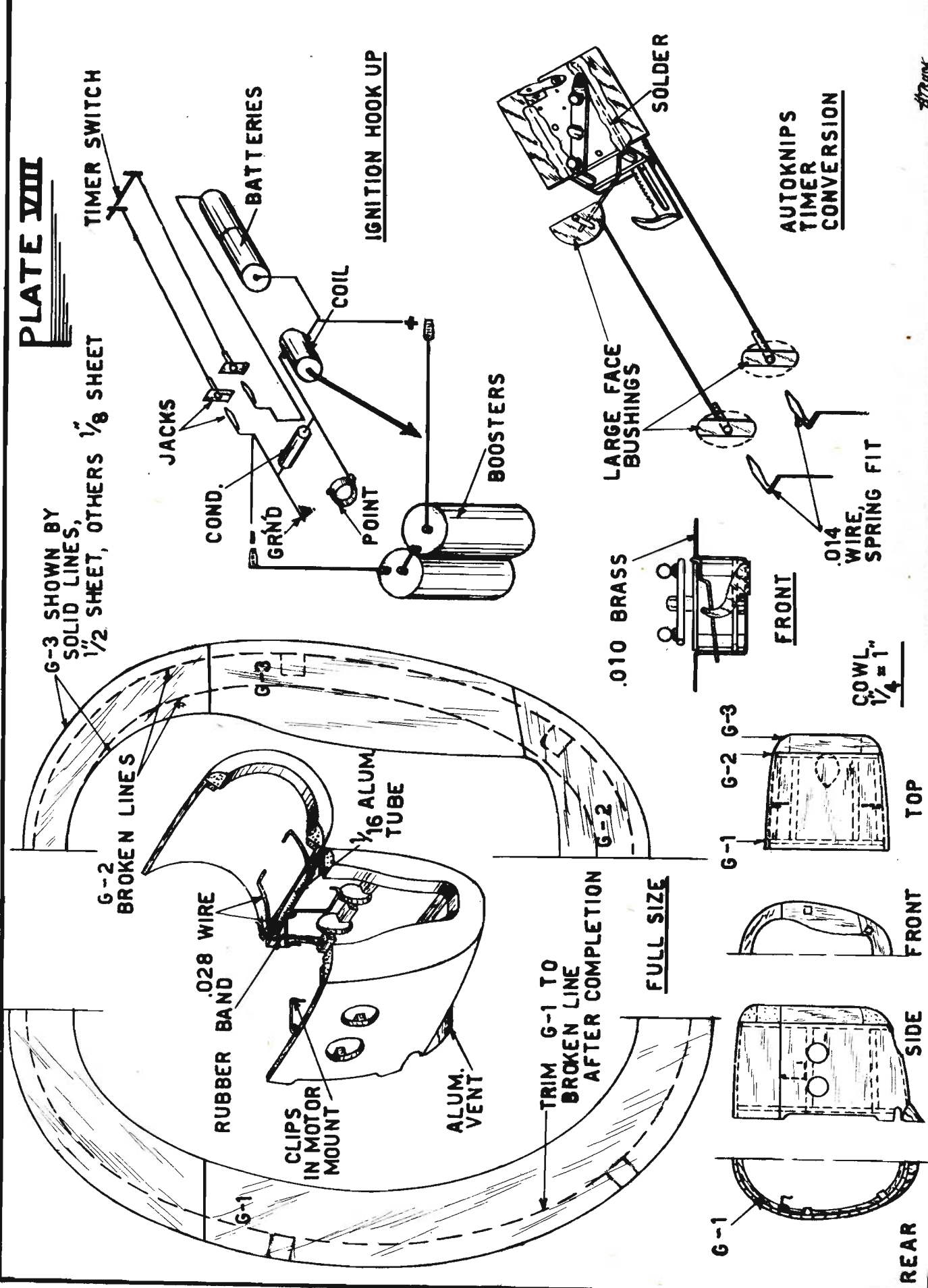

**AUTOKNIPS
TIMER
CONVERSION**

4/20/47

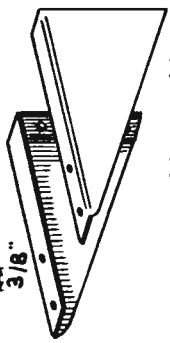
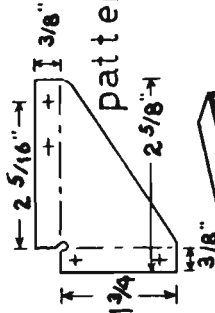
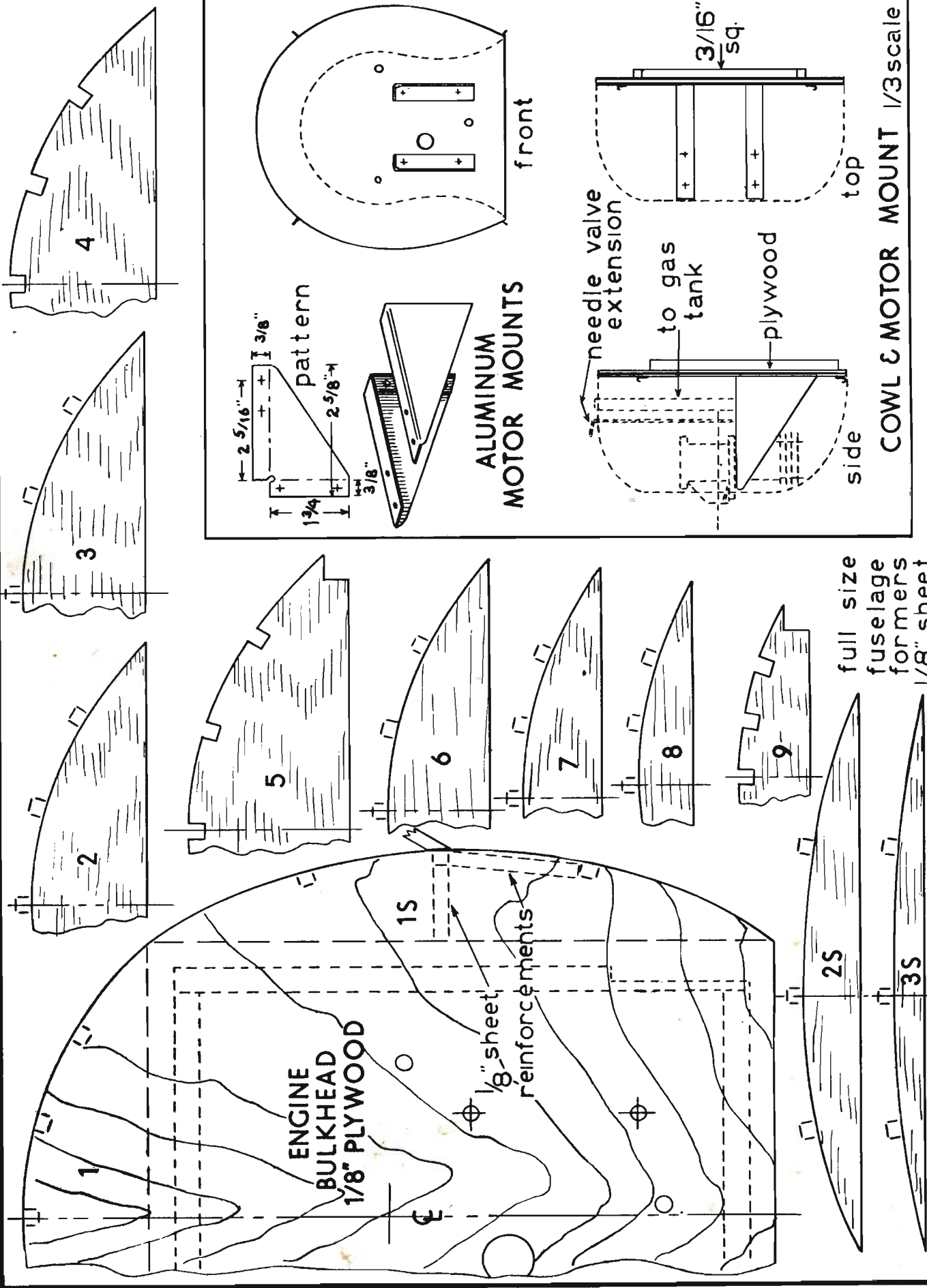

**ALUMINUM
MOTOR MOUNTS**

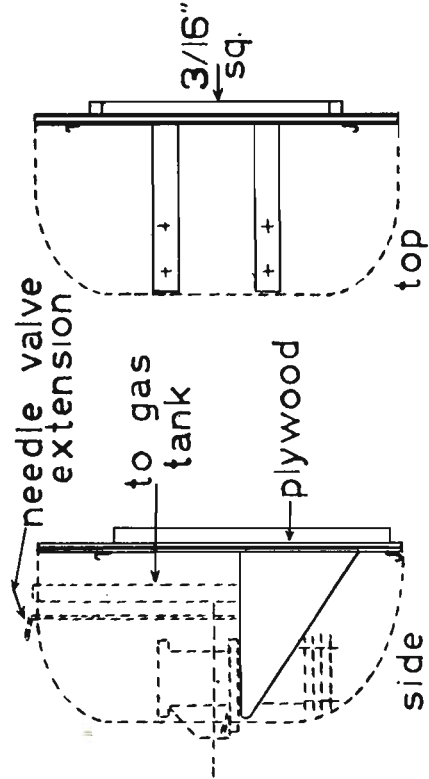
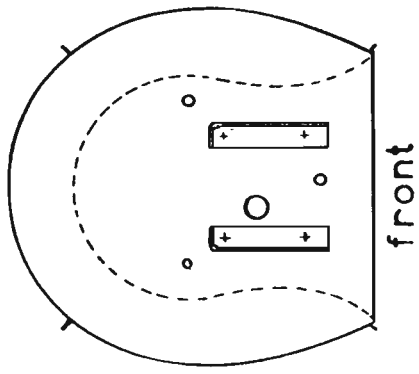

COWL & MOTOR MOUNT 1/3 scale

full size
fuselage
formers
1/8" sheet