



Björn Holmberg (left) and Mats Johansson powered their *Dart 2*s with a Thunder-Tiger .25 and a Veco .19. Gösta Johansson photo.

# DART 2

By MATS JOHANSSON . . . This construction project for a .19-size, parasol wing, R/C trainer comes to you from Sweden. The *Dart 2* is an easy to fly, stable, and strong R/C model plane.

• The *Dart 2* is a new Swedish trainer for R/C control. It is designed for those modelers who want an airplane that is easy to fly and also is good looking. *Dart 2* has been developed and improved during a period of four years. Special characteristics are that it is very easy to fly, robust, and looks like a real aircraft.

## FUSELAGE CONSTRUCTION

Start with the two fuselage sides which are constructed of 3/32 balsa (the contour lines are denoted by dark arrows on the plan). Then make the 1/32 plywood reinforcement parts (white arrows). Now, glue these on each fuselage side. See to it that you make one left and one right fuselage side. After that you continue with the 1/8 x 3/8 spruce stringers which you glue into position. Note that the part of the stringer which is attached to the plywood should be edge to edge, while the part of the spruce stringer which is glued directly to the balsa surface should overlap the balsa edge by approximately 5/32 inch. Study the plan carefully when you do this. Also cut out the part of the spruce stringer where the stabilizer should be located.

Proceed with the 3/8 triangular stringers along the lower edge of the sides. Continue by making the bulkheads. Note that the firewall and bulkhead Nos. 2 and 3 are of sandwich construction. Also, make the bulkheads A,B,C, and D for the detachable hoods. Now, attach the firewall and bulkhead Nos. 2 and 3 perpendicularly to one fuselage side. Let the glue dry and then add the other fuselage side. Join the two tail ends and check that the framework is straight.

Proceed by attaching bulkheads 4,5,6, and 7, and the top stringer between bulkhead 3 and 4, and between 5 and 7.

While everything is drying, cut out the 1/8 plywood reinforcement for the landing gear, and glue the 1/8 x 3/8 spruce pieces into place. Then drill 1/8 inch holes for the landing gear clips through both spruce and plywood. Continue by cutting out the necessary space in the triangular stringers for the landing gear reinforcement. Then, glue this one in place.

Now, mount your favorite pushrod cables and also install a tube for the antenna. Then, glue the tailwheel reinforcement of 1/16 plywood in place. Now, cover the underside of the fuselage with 3/32 balsa, cross-grain. After that, you attach the turtle deck of 1/16

soft balsa.

Proceed with the two detachable hoods. Please note that bulkheads C and D should have a cover piece of 1/32 plywood. The hood frame consists of two bulkheads and three pieces of 3/16 square balsa stringer. The frames are covered with 1/16 balsa. Make sure that the two hoods fit properly on the fuselage. As the rear hood will keep the cabane strut in position, it's very important that it is correctly mounted to the fuselage. (See sketch for details.)

The lock device I use is the one shown in the figure. You will have to make four of these.

When you are ready with the hoods, you continue by shaping the fuselage to a smooth and beautiful shape. When the fuselage is done, you may proceed with



Author's latest *Dart 2* is all framed up and ready for covering. Changes include bubble cockpit canopy and engine cowl.

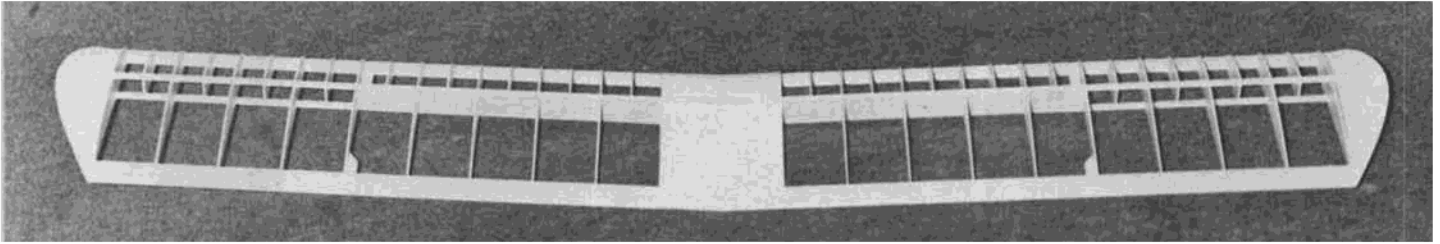

When the wing is completely framed up and ready for covering, it will look like this.

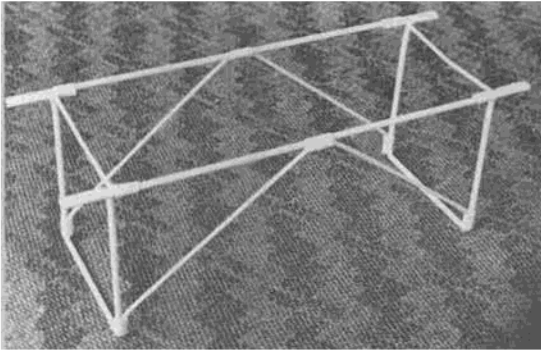

Cabane strut detail. Wrap main wires with fine copper wire and solder firmly, paint.



The completed *Dart 2* ready for test flights. This one is powered with a Thunder-Tiger .25, but the *Dart 2* will fly very nicely on a .19. (That's snow under those tires, not concrete!)

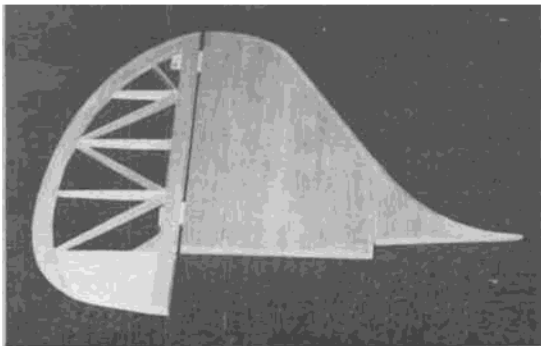

LEFT: Sheet fin and built-up rudder are ready for covering. Stabilizer is also a sheet/built-up structure.

RIGHT: The landing gear of the *Dart 2* is fixed with four clips. Paint the landing gear for lasting beauty.

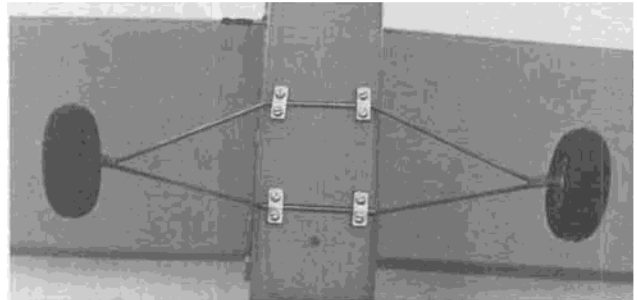

### WING CONSTRUCTION

The wing construction is very simple, and you'll start by cutting out all the ribs. Now, cover the plan with thin plastic film and pin the leading edge (3/8 square balsa) and the lower piece of the trailing edge (1/16 x 1 balsa). Also, pin the lower piece of the main spar (3/16 square spruce) to the plan. Then, glue all ribs except rib No. 1 in place. Also, glue all support ribs (half-ribs) in place and

add the upper part of the main spar. Allow the glue to dry and then block up the wingtip at the TE about 3/8 in. for washout. Now you add the upper part of the TE. Also, glue the 3/32 shear webs in position. Your next step will be to add the wingtip which is made of 1/8 balsa. Sand it to the shape shown on the plan. Then, you make the other wing in the same way.

Now you join the two wings together. Make the two dihedral braces of 3/32 plywood and the LE reinforcement of 1/16 plywood. Block up each tip 1-3/8 inches and sand the spar ends so that they fit perfectly to each other. Glue the joints with epoxy and let them dry. Then you attach the center rib (No. 1, which consists of a front piece and a rear

*Continued on page 86*

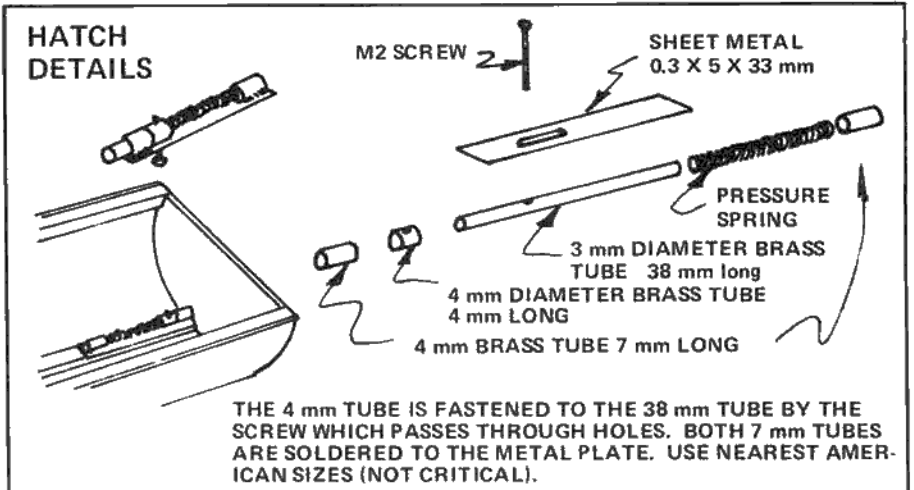
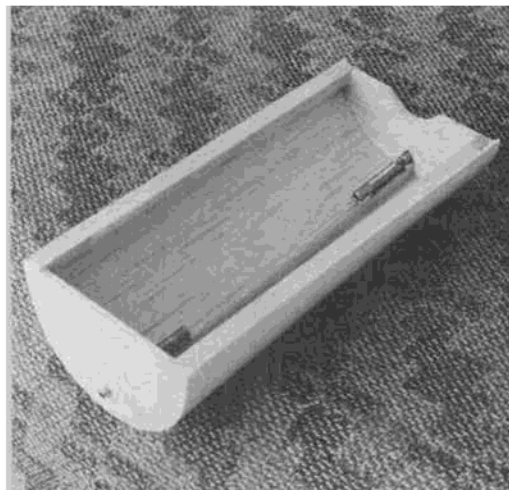

piece). Now, cover the center section of the wing with 1/16 balsa. Sand the wing smooth and shape the leading edge. If you can find the plan in the balsa dust, dust it off and continue with the . . .

#### **STABILIZER AND FIN CONSTRUCTION**

The construction of the stabilizer, the elevator, the fin, and the rudder is of the traditional kind. The stabilizer and fin consist of a framework of balsa stringers which are covered on both sides with 1/16 balsa. The elevator and rudder are covered with silk or any heat shrink film. Note that the two elevator halves are connected with a 1/16 diameter piano wire tie. Now, over to the metalwork . . .

#### **LANDING GEAR AND CABANE**

##### **STRUT CONSTRUCTION**

The landing gear on the *Dart 2* consists of two pieces of 1/8 piano wire which shall be soldered together. Begin with the front piece, and make the rear strut so that it fits properly with the front strut. Then, bind and solder the two joints. Attach two aircraft type wheels, and continue with the tail wheel assembly. Follow the plan carefully and finally epoxy the tail wheel assembly to the fuselage.

Now, proceed with the cabane strut. On this detail, it's very important that you work carefully and exactly. The whole assembly is made of 3/32 and 1/8 piano wire, and all joints are bound and soldered. Note that the rear strut is 5/32 shorter than the front strut (for proper incidence). When the cabane strut is finished, check that it fits in the fuselage. You must also make sure that the rear hood fits, and that its lock devices really work. Fit the stabilizer and fin with tape, position the engine, put the wing on the cabane strut, stand back and enjoy!

##### **FINISHING THE DART 2**

Cover the entire model with your favorite covering material, and if you didn't use any heat shrink film you may now paint the plane in any color of your choice. When you are satisfied with the finish, you can install the engine (an ordinary .19 engine is just great), a five to ten-ounce tank, the landing gear with clips, and your three-channel radio gear. Attach the wing to the cabane strut with at least six rubber bands and locate the CG. It shall be located just under the main spar. Of course, you haven't forgotten to install a pilot and a windshield!

I hope you will find the *Dart 2* most pleasing to fly as I do, and I think it will give you many hours of flying fun.

Be smart, fly *Dart*. ●