



COMBAT GREMLIN

A Flying Wing Combat Design

By Eric Henderson

The Concept

For many years Control Line Combat has been recognized as a tremendously exciting form of contest. Combat addresses a primeval and very human appetite for one on one dueling. The Combat Gremlin has given R/C Combat a major shot of viability and has addressed the two major stumbling blocks of expense and building time.

It began with the thought that R/C flying is theoretically a non-contact sport. Therefore, how about designing a plane that is regularly expected to make some form of pretty hard contact? Several trainers were considered, seeing as how the toughness need has already been achieved with a

couple of notables. The problem with this approach was that either they cost a "lot" of money or, to put it politely, they lacked aerobatic performance! Even a tough trainer has too many parts compared to a U-control set-up. What I was looking for was an aerobatic plane that would meet the rigors of combat. A plane that could almost always be field repaired. What I wanted was something that was as good as the U-Control crowd had!

Many hours were spent wrestling with the design concepts, but I consistently tripped over my accumulated model building experience. Boy! was I conditioned to build and design in a very narrow corridor. In the end I wrote a sign and hung it up above my workbench. It said, "If you build it, they

will break it!" A play on words from the movie "Field of Dreams." This freed up my thinking patterns and the Combat Gremlin was conceived.

The Design

The Combat Gremlin was designed from "Impact" backwards. It had to bend rather than break. It had to allow every part to be "field replaceable." The end result was a plane that was light and forgiving. It employed a self-contained fuselage that was attached to a semi-disposable wing. A flying wing was chosen because it has fewer bits to break. **Figure 1 shows the basic layout.** The fuselage contained all the delicate parts and can be removed by only unscrewing three wing bolts and the disconnection of two clevises. It would



The Central Massachusetts Radio Control Modelers Combat Gremlin Tournament participants. From left to right: Charlie Watt, Bill Lewis, Steve Smith, Dan Weier, Dan Miner, Dan Snow, Lamar Phillips, "Evil Eric" Henderson, Jim Cavanaugh, Jim Reith, and George Higgins. Photo by Harvey Thomasian.



ABOUT THE AUTHOR

Eric Henderson, 43, is a very active modeler who originates from the United Kingdom. He and his family now live in the Boston, Massachusetts, area where they have been for the last nine years.

He began building JETEX models when he was age six and soon progressed to U-control. Combat and his diesel "PAW 3.2 Combat Special" being his main focus.

After finding a very supportive wife who gave him five children and permission to buy a radio controlled plane, he was launched into proportional R/C models. His most favorite type of flying is either Slope racing, Pattern or Fun-flies.

Eric is very active in club life and is the President of DECRCM, a Digital Equipment Corp. club, the Treasurer of the Lazy Loopers Flying Club in Norfolk, Massachusetts, a member of the Board of Directors of Central Massachusetts Radio Control Modelers. He is also a regular member of two other clubs.

His nickname of "Evil-Eric" was not earned by his current habit of corrupting normal R/C fliers and turning them into flying demons, but was actually gained in recognition of his slope racing strategies. The Combat Gremlins are merely an extension of the fun that he brings to R/C flying.

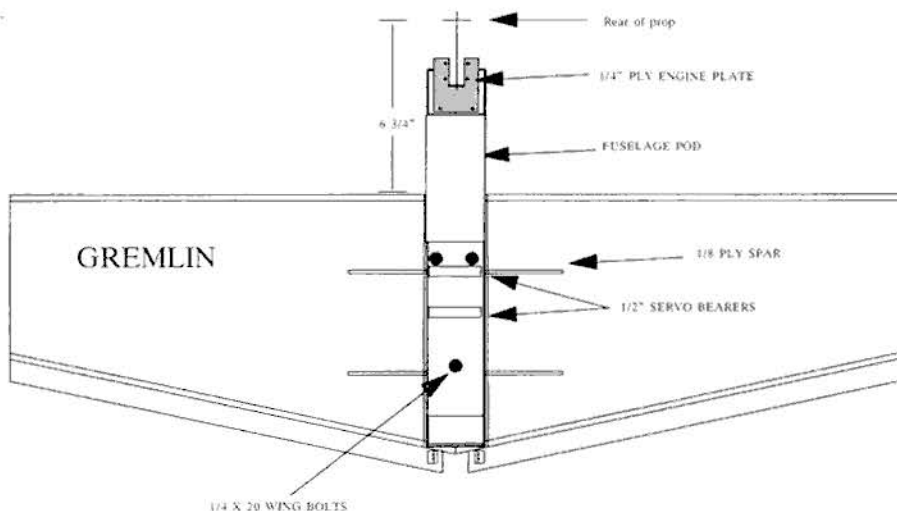

Plan view of Combat Gremlin showing position of wing bolts, servo rails and engine plate position.

FIGURE #1

prove to be very quick to make. With base materials such as plastic down-pipe and 2" insulation foam it would also prove to be very inexpensive to make. Both of these principal materials are readily available from local building suppliers.

The engine chosen was the O.S. .25, plain bearing FP. (Any equivalent plain bearing engine will do.) This is a relatively inexpensive, simple, tough, and reliable R/C engine. (It was also easily stolen from my son's trainer.) Any radio can be used. If it has elevon capability, you are all set; if it does not, a simple, but very strong, sliding tray was developed to meet your needs. It is made from NyRod scraps and is once again field maintainable. As an alternative you can also add elevon capability to the R/X with a Christy Mixer. A comment reached me that the Combat Gremlin was the perfect

answer to the question of what to do with all of that non-1991 radio equipment before your club outlaws it?

Testing

I would love to say that the flight testing was perfect, but it definitely was not! During testing of the prototype, we crashed it 17 times in a row. We began testing with a seriously rearward C.G. (35% instead of 15% — some smart designer, eh!). The first flight was a loop of about 3' in diameter, the second was about 4' forward and 10' back towards the pilot. This gave us serious doubts about both the design and the cure. A tail heavy flying wing is impossible to control. We added weight and moved everything forward many times but it took a whole afternoon to get a partial result. In all of the often, very heavy crashing, the Combat Gremlin never broke. We did break

Combat Gremlin - Elevon mixer set up.

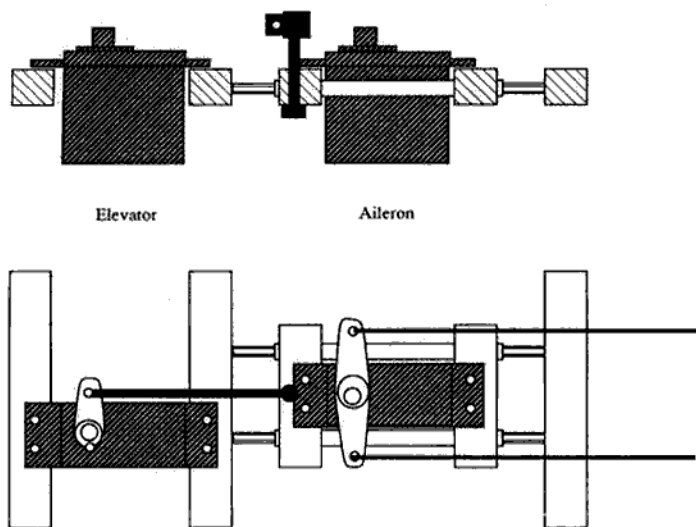

FIGURE #2

a couple of props, but the forgiving nature of the design was evident right from the beginning. We wisely did test over the long grass but usually missed it completely.

The inside story here is that my fellow wizard, Dan Snow, had rushed ahead and finished his version one "midnight oil burning day" ahead of mine. With mixed feelings, we tested his first, it was completely uncontrollable. After two attempts he gave me the box and said, "Here, you designed it, you fly it!" We kept it, bending the sticks and adding lead until we got a 15 second flight. By then we "really" knew what was wrong but had to retire for the day. We raced back to our respective workshops to more professionally move the fuselages forward to a 15% balance point.

I got my modified version to the flying field first and was rewarded with a beautiful test flight. I must thank Dan Snow, aka "The Snowman," for exposing the C.G. problem before I tested my own, grin, grin! We knew from the moment we pushed it out into the blue yonder that it was a winner. When it slid to a graceful stop on the grass runway we all let out a few hoots and whoops! Club members who had witnessed the initial test flights the day before, slowly came out from under the protective cover of the trees and began to show a lot of genuine interest. To date, we (The Snowman and I) have cut out for over 120 sets of Combat Gremlin wing cores. As one would say back in the U.K., "There are Gremlins every bloody where." It is not uncommon for me to arrive at the field and to see nothing but Combat Gremlins flying or in the pits.

All the design decisions are still proving to be valid. The 1/4" ply engine plate breaks before the fuselage or, more importantly, the engine. "Landing" inverted at full throttle proved that one (they were supposed to be low passes but the ground moved, again)! The power and

Combat Gremlin - Elevon Mixer Components.

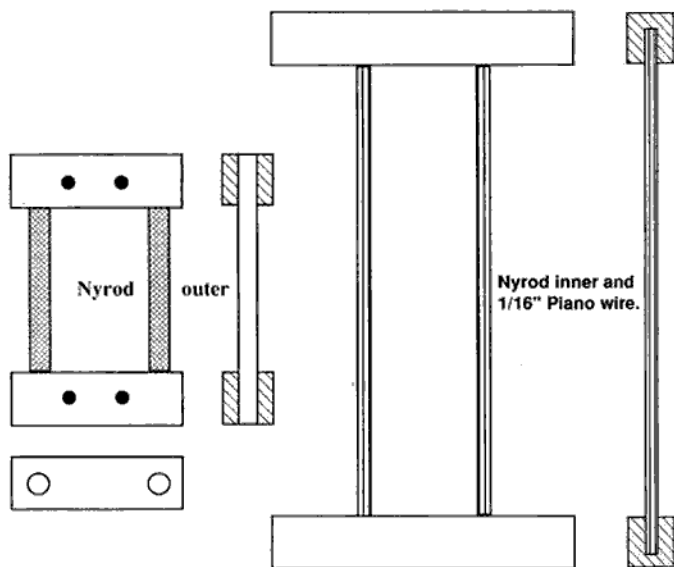

FIGURE #3

guidance systems are indeed well protected and readily removed as a module. They can be removed and fitted to another wing in less than five minutes. Three wing bolts and two clevises are all that need to be disconnected. The wings can be readily field repaired with UFO and/or duct tape. Two fins allow for one to be "lost" and the plane still flies well, they are also replaceable in minutes.

I take the following spares with me to a combat session. A spare wing or two, engine plates, two fins, and a fuel tank. I also take several 9 x 6 APC propellers and some 4-40 bolts and a bottle of UFO. The Combat Gremlin will fly in a pretty beaten-up state. I even went so far as to fly one week with a wingspan reduced to 36" with no problems.

Combat And The Combatants

This form of flying is not for everyone but any post-novice pilot can do it, and do it well. Unlike U-control, where the fastest

aggressor usually wins, R/C combat has a **huge** element of **luck** involved. With relatively equal aircraft and the need to get close to the other guy, it is very common for a plane to fly its streamer in the way of another plane's propeller! If you are both looping after each other it is anyone's guess who will get a cut. This makes the result much less predictable and humbles many a club "hotshot" (the author included — several times).

Safety is a factor that must not be ignored. Fortunately, Combat Gremlins are inherently light and if mid-aired beyond flyability, they tend to just flutter down to earth. We **always** chose a flying space that has **nothing** significant under it. No people, cars, property, or forest. This has proven to be a really good policy and significantly fosters and helps the enjoyment. It also helps in "downed model" recovery. We use biodegradable part streamers and string to make sure the mess that we cannot find is

Wing bolt block detail.

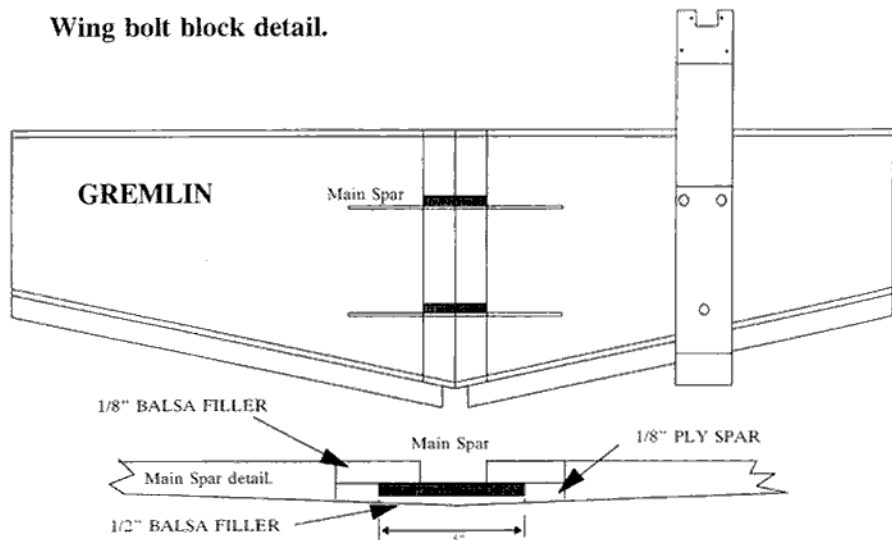
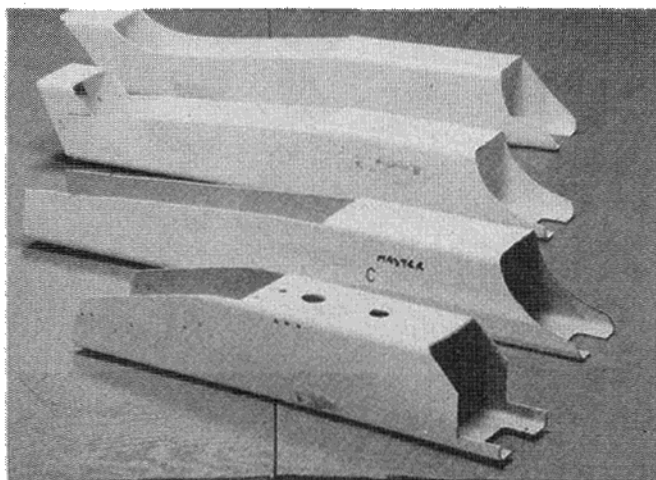
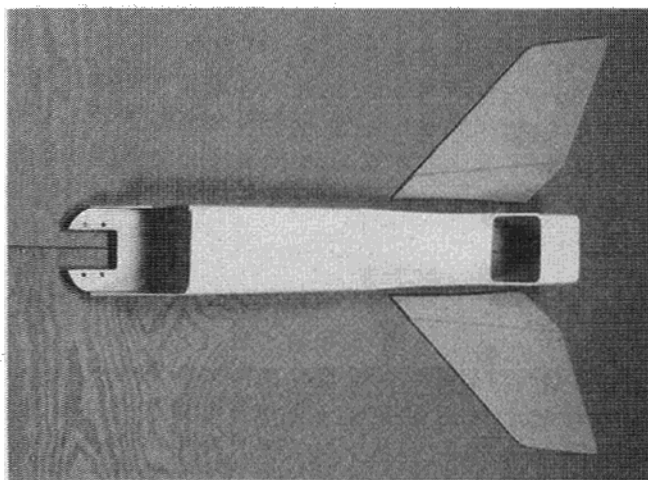

FIGURE #4



Fuselage development — fuselage is made from plastic down-pipe available from your local building supply store.



Fuselage is shown here with break-away engine mount and fins; both are bolted to fuselage for easy repair.

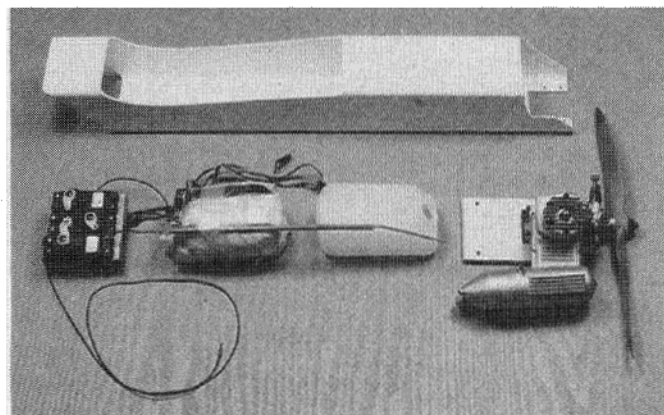

Bare fuselage is shown with O.S. .32 engine, engine mount plate, 4 oz. slant tank, receiver/battery switch assembly, and servo assembly for radios, with elevon mixing capabilities.

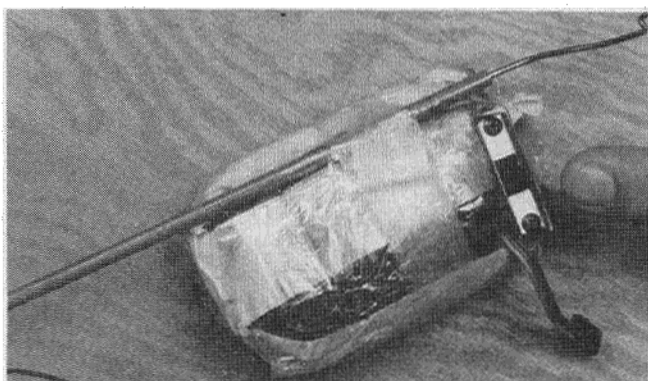

Receiver-Battery switch assembly is wrapped in foam, covered with plastic wrap (to protect against oil and fuel), and taped up. Outer NyRod extends past fuel tank to engine, allowing a free passage for the throttle pushrod.

not a problem to anyone else.

The Rules

The base rules that we use for combat are designed to get a winner in every round, no matter what happens!

(1) A three minute round with the first cut as the winner. (If a combatant cuts their own streamer they immediately lose.)

(2) If either plane does not last three minutes the last one down wins (e.g., sick engine, dead-stick, mid-aired, or one crashes).

(3) If there is no cut and both planes fly for the three minutes, the nearest to a

pre-defined landing spot wins.

(4) Maximum of two launches to get airborne or you lose.

(5) Streamers are 3" party type crepe paper that is 15' long with a 20' "kite string" leader. (No nylon allowed.)

You can use a league or play-off system of your choice to determine the overall champion.

CONSTRUCTION

Start With The Wing

Assuming that you have cut out or obtained your foam cores, cut the 1/2" TE

stock for the elevons to match the wing halves size minus a 1/8" each to give control clearance at the center. Keep the excess stock for use with the fins. Then fit the 1/4" LE and TE with white wood glue. Scrape off excess before joining parts. Only apply glue to the foam, holding the parts in place with masking tape. For speed you can use Satellite City's UFO for this task. Cut fin parts and assemble using UFO on top of "Cling Wrap" to prevent them sticking to your workbench. Add cross grain at tips to prevent warping (if they last that long!). Fit spare aileron stock to base of fin to give

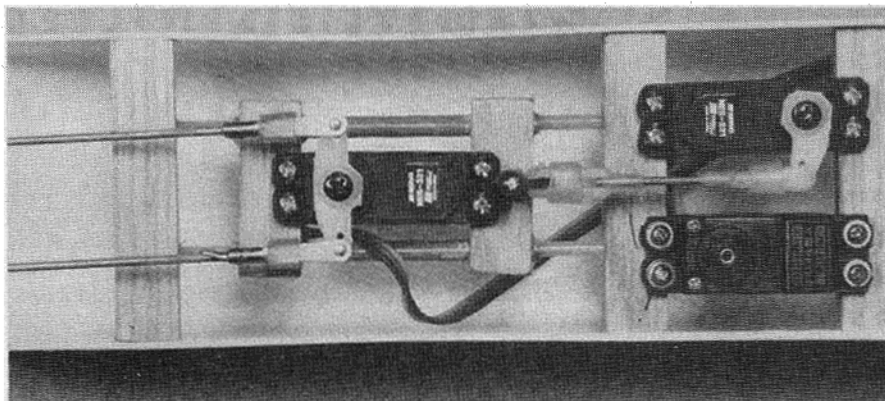

A simple sliding tray may be built from NyRod scraps and plywood. Inner NyRod is also supported with 1/16" music wire inside. Servo rails are screwed in from outside of fuselage.



Author "Evil Eric" adjusting a non-mixing type of radio that employs the simple slider to achieve elevon control.

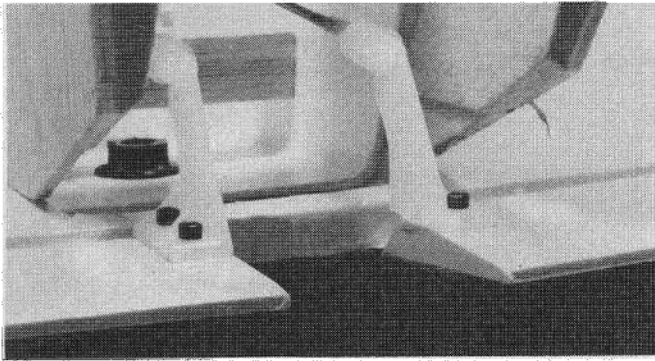

Elevator and ailerons at neutral.

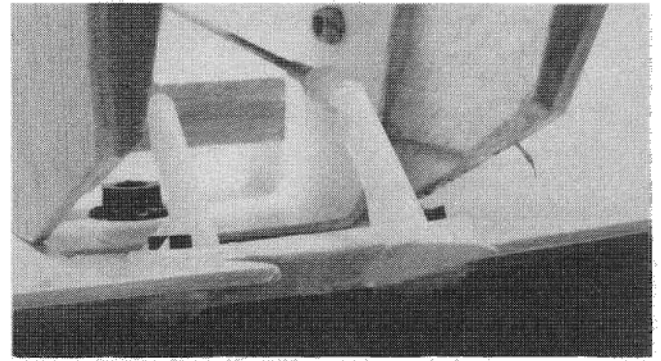

Elevator in "up" position.



COMBAT GREMLIN

Designed By:

Eric Henderson

TYPE AIRCRAFT

Flying Wing — Combat

WINGSPAN

48 Inches (44" Opt.)

WING CHORD

13.5" Root; 11" Tip

TOTAL WING AREA

48' = 588 Sq. In.

44' = 550 Sq. In.

WING LOCATION

NA

AIRFOIL

Symmetrical

WING PLANFORM

Trailing Edge Swept Forward

DIHEDRAL, EACH TIP

Flat on Top

OVERALL FUSELAGE LENGTH

18 1/4 Inches

VERTICAL FIN HEIGHT

7 Inches

VERTICAL FIN WIDTH (Incl. rud.)

6 Inches (Avg.)

REC. ENGINE SIZE

.25 2-stroke or .40 4-stroke

FUEL TANK SIZE

4 Oz. Combat, 6 Oz. Opt.

LANDING GEAR

Very Optional

REC. NO. OF CHANNELS

3

CONTROL FUNCTIONS

Throttle & Elevons

BASIC MATERIALS USED IN CONSTRUCTION

Fuselage Plastic Down Pipe

Wing White Foam, Balsa & Ply

Wt. Ready To Fly 48 Ozs. (3 Lbs.)

Wing Loading 48" = 11.75 Oz./Sq. Ft.

44" = 12.80 Oz./Sq. Ft.

angle when fitted to fuselage pod. Ensure that you make a left and a right hand fin. Prepare 3/4" diameter plates of 1/32" ply to use where the bolt holes will be. Do not glue them on until later when you will know exactly where the bolt holes will be.

Now Turn To The Fuselage Pod

Use a band saw or jig-saw to cut the down-pipe to match the template. Clean the burrs off the edges with a razor blade or X-Acto knife. Cut the 1/4" ply engine plate out and round off the lower corners to fit snugly into fuselage. Clamp in place with rear edges of engine cut-outs aligned. Drill the rear two holes to accommodate 4-40 bolts. Bolt in place and remove clamp.

Mark holes for engine and drill. Bolt on the engine with 4-40 bolts and lock nuts using washers where the lock nuts touch the ply or the fuselage. Install the 4 oz. tank wrapped in 1/2" foam. Tape the receiver NiCds together and install behind the fuel tank. Do this temporarily to assist in determining the C.G. Mount the three servos on 1/2" rails and fit them closely behind the receiver; if the simple mixer is being used, three rails servo rails will be required. Fix the ends of the rails with small 3/8-2 screws through the fuselage sides. Note, for engines larger than .25 cu. in. all four engine bolts can be run through the fuselage for added rigidity.

Now Return To The Wing

Round off the LE to match the wing section and sand the ends flush with the foam. Cut the two 1/8" ply spars to pattern. You can use 3/16" or 3mm for more strength. Cut the two wing bolt blocks and tap the three holes with a 1/4-20 thread. You can use captive nuts (blind nuts) if you prefer. The two front holes are 1/2" apart (3/4" each from the centerline). Lay the wings upside down to join them. Ensure that the TE and LE are the same height during this process. Tack the balsa fillers to the main spar as illustrated. Insert both the spars into pre-cut wing slots. Join the wing panels using 5-minute epoxy or UFO. With a very sharp knife cut recesses in the foam to accommodate the wing bolt blocks. The wing bolt blocks are key to the strength of the wing and need to fit closely to the foam. Glue in the wing bolt blocks with 5-minute epoxy. Cut a hinge angle on the elevons and dry fit to TE. Leave a 1" gap between the inboard ends.

Place the fuselage in position. It should sit with the bottom line of the fuselage exactly in line with the centerline of the wing section (remove any material that prevents this condition). Be sure you have fitted the muffler, prop, etc. Also position the fins with masking tape. Now try the

Materials List

- A sheet of 2" insulation foam 8' x 2', and a length of plastic down pipe (they come in 10' lengths).
- Two 1/4" x 5/8" LE's and Two 1/4" x 3/8" TE's (24" each). Two 1 1/2" TE stock 24" each.
- One 1/2" sq. x 6" select pine rear-wing bolt block. One 1/2" x 3/4" x 6" select pine main wing bolt block.
- 1/8" x 4" x 36" sheet for fins.
- 1/4" ply engine plate (approx. 2 1/2" x 3 1/2").
- Three 1/4-20 nylon wing bolts.
- Ten 4-40 bolts and lock nuts.
- Two large elevator horns and two pushwires and connectors for elevons.
- Eight Du-Bro hinges.
- O.S. 25FP (builders choice), 4 oz. tank, filter, fuel line, 9 x 6 prop and spinner.
- Radio (minimum 3-channel 3-servos).
- 1/16" throttle pushwire and outer NyRod (use EZ connector).
- Two 3" x 1/2" sq. servo bearers (4 if you use the mixer tray).
- Two 1/8" ply wing braces (approx. 12" x 1" each).
- UFO or 5-minute Epoxy to join wing halves.
- Finishing Epoxy with 50% alcohol for water and fuel risk areas. (Envirotex Bar-Topping is a good and less expensive alternative.)
- 4" glass cloth for underside landing area and .6 oz. glass cloth for rest of lower area and 12" of top area (optional).
- 1" wide fiberglass reinforced adhesive tape for wing "spars."
- White wood glue for TE and LE (optional).

C.G., it must be 1.6"-2" from the LE. If not, slide the pod backwards or forward until this point is achieved. Mark the position of the wing bolts through the bottom of the wing (you may have to trim some material off of the pod). Do not worry if the pod does not reach the rear of the wing — an inch here is not critical. A good rule of thumb "start-point" here is to position the rear of the prop hub approximately 6 1/2" from the LE. Drill 1/4" holes in the pod and fit to the wing. Refit the NiCds, receiver, and servos, and bolt on the fins. The rear

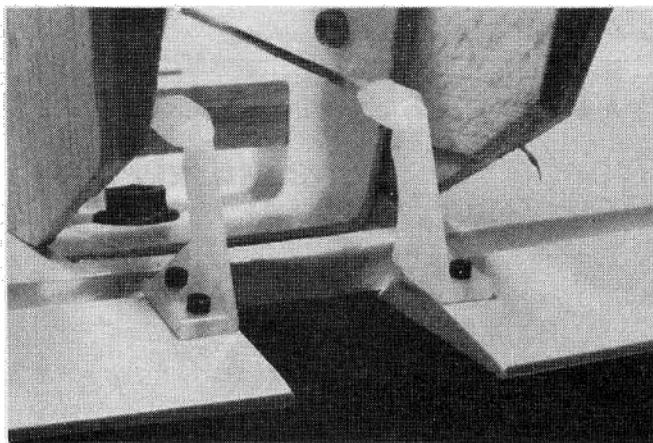

Elevator in "down" position.

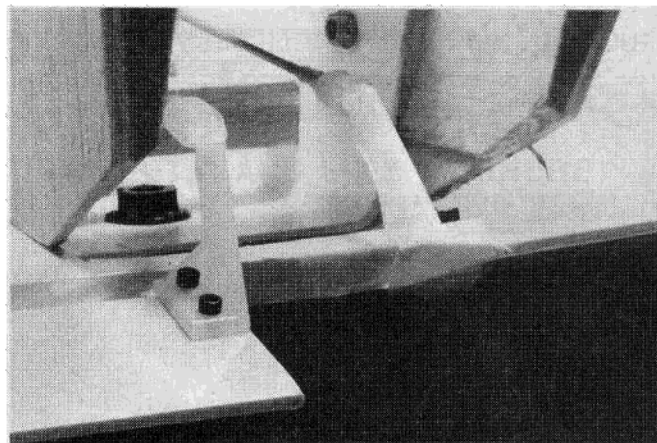

"Right" aileron position.

edge of the pod should be just before the hinge line of the elevons. Fit the elevon horns and push-wires. Use a wire pushrod to the engine. A 6" piece of outer NyRod will prevent the wire from binding on the tank, etc. The throttle arm is best placed in the upright position. Recheck the C.G. again — the plane must hang level with an empty fuel tank. Then disassemble the Gremlin. Run two lengths of 1" fiberglass reinforced adhesive tape spanwise along the wing about 3" back from the LE. Do this all the way around, on both the top and bottom of the wing. Start and finish in the pre-cut pod bay. Apply a 4" fiberglass bandage to the bottom of the wing using thinned "Finishing Epoxy" resin. An option here would be to cover the complete bottom of the wing with .6 oz. glass cloth and 50% thinned finishing resin if you want a longer lasting wing. To fuelproof the top of the wing, paint a band of epoxy resin 6"-8" out from the center of the wing on each panel. It is a good idea to fit a tail skid to protect the elevons if you are using the Gremlin for non-combat, longer lasting purposes.

Final Assembly

Fit the elevon hinges using 5-minute epoxy. It is best to use five hinges per elevon. Fit the rear bolts of the engine plate. Use round head bolts under the tank to give better clearance. Slide the tank in behind the engine wrapped in foam and taped. Fit the engine and muffler, tubing and filter, etc.

(The use of an exhaust diverter is advised to prevent the fuselage getting too oily.) Attach the pod to the wing with 1/4-20 nylon wing bolts. Plug in the servos, switch, and NiCds. Wrap the NiCds and receiver in foam and then tape them together. Wrap the whole package in "Cling-Wrap" or a plastic bag and tape closed. Tape the switch to the rear of the bundle as shown in the photos. Then tape a 6" piece of outer NyRod to the bundle to prevent it moving when used to guide the throttle wire.

Insert the complete assembly into the fuselage pod so that the switch is at the rear and the outer NyRod pushes past the tank on the throttle arm side. Fit the servo rails and servos into fuselage pod. Connect the push-wires and set throws to 3/8" up and down for elevator and aileron; you can add more later if you need it! It is a good idea to draw a datum line on each wingtip to help you line up the elevons. They should be set at 0° for initial flights.

Please Note: For a flying wing, up is still up and down is still down. Both elevons have to move together to give elevator response. Set throttle so that it can be closed from the transmitter — very important for landing with no wheels. For similar reasons, set the prop so that it freewheels to the horizontal position when the engine cuts. Now all that is left to do is route the antenna. You can just leave it hanging out

the back but it is better if you run it through a piece of inner NyRod and position it like an R/C car antenna in the rear cross-bar of the fuselage. Check the C.G. again, and you are ready to fly. Well, maybe not! It is a very good idea to decorate the wing very brightly. If you spray, please do a test piece first as many spray paints will dissolve the wing. You can also cover the wing with low-temp plastic film if you so desire. Low-temp fluorescent was used by the designer and, although the color does not photograph well, his combat motto does.

Flying A Combat Gremlin

The Combat Gremlin is a fully symmetrical wing and does not care which way is up when it flies. It is an easy plane to fly and will stay up on high idle or zip around on full throttle with ease. It has no wheels and needs to be land-launched. Most folks launch the plane themselves. They hold the plane from above, by the fuselage pod on the C.G. and do a simple one step and push action that throws the Combat Gremlin upwards at about a 15° angle. The plane just flies away like a freshly released homing pigeon.

Flying wings have some properties of their own that really are not obvious if you just watch them fly. There is a feeling that you get that is often described as "rock-solid." This is because you get almost no pitch variation even on a windy day. The short moment arm between the

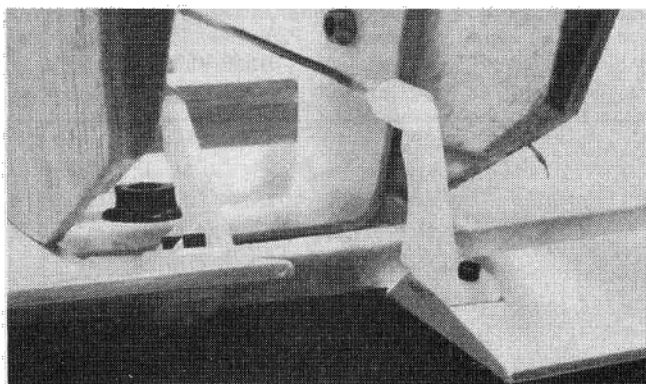

"Left" aileron position.

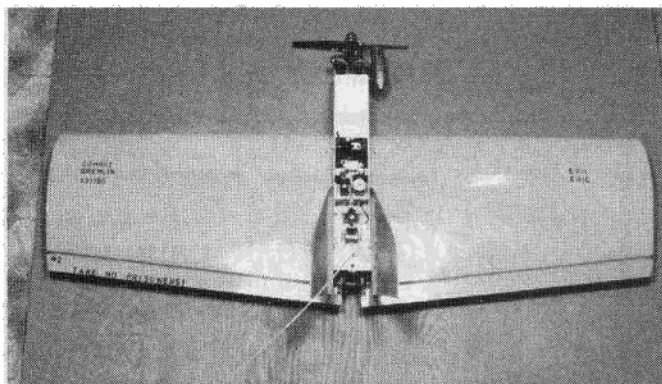

Combat ready Gremlin.

elevator and the C.G. accounts for much of this. There is an immediate "feeling of comfort" between the pilot and the plane. All Combat Gremlin fliers report this sensation.

The Combat Gremlin loops and bunts well. A bunt is C/L lingo for an outside loop! The plane can be set up to spin. You will have to use a lot of elevator to induce this condition. Adding in aileron control will not help the spin because it reduces the throw of one of the elevators. I set my Combat Gremlins up so that they will **not stall at full elevator deflection**. This is because in the heat of battle you need a plane with no bad habits — trust me on that one. (I do, however, have a high rate switch setting so that spins can be induced when I am not flying combat.)

Flying combat is an adrenalin high and probably much safer than many other stimulants. It reaches the basic thing that is in all of us. It really is "Snoopy" against the "Bloody Red Baron" with no room for error. My son thinks it is better than Nintendo! All of you parents out there will know how significant that is. Give Gremlin Combat a try and you will have some fun that will make you feel as good (if not better) than that "first flight" that we all took.

A Word Of Warning

These little beggars grow on you. **Do not add water** or else they will multiply. Don't put **too** much care into the building of one. Some of my friends did and an alarming thing has happened. They built "Sunday" versions that they have become attached to

and that they just fly for fun. They made them pretty and won't fly in contests or do combat with them. There is a growing trend to make versions with much bigger engines. Both 2-stroke and 4-stroke engines have been used. A K&B 20 did well and a YS45 was equivalent to flying a ducted fan. I have even heard of a diesel version. What next, I wonder? Well it has already happened. A 64" version was built by Wally Richardson and flown with a ST2000 on the front. It was too big to hand launch solo, so his buddy, Dick Durant, fitted 1/4 scale wheels (okay I admit it, I did cut the cores!).

If you would like a normal Combat Gremlin wing core set just contact: Reith Associates, P.O. Box 863, Southbridge, Massachusetts 01550, (508) 765-9998.



**By H.E
RCModeler
Dec. 1992**