

# Cessna 182

## SKYLANE™



### WARRANTY.....

Top Flite Models guarantees this kit to be free of defects in both materials and workmanship at the date of purchase. This warranty does not cover any component parts damaged by use or modification. In no case shall Top Flite's liability exceed the original cost of the purchased kit. Further, Top Flite reserves the right to change or modify this warranty without notice.

In that Top Flite has no control over the final assembly or material used for final assembly, no liability shall be assumed nor accepted for any damage resulting from the use by the user of the final user-assembled product. By the act of using the user-assembled product the user accepts all resulting liability.

If the buyer is not prepared to accept the liability associated with the use of this product, the buyer is advised to immediately return this kit in new and unused condition to the place of purchase.



Top Flite Models  
P.O. Box 788  
Urbana, IL 61803

Technical Assistance - Call (217) 398-8970  
[www.top-flite.com](http://www.top-flite.com)

READ THROUGH THIS INSTRUCTION BOOK FIRST. IT CONTAINS IMPORTANT INSTRUCTIONS AND WARNINGS CONCERNING THE ASSEMBLY AND USE OF THIS MODEL.

# TABLE OF CONTENTS AND BUILDING SEQUENCE

<b>INTRODUCTION</b> .....	<b>3</b>	<b>BUILD THE FUSELAGE</b> .....	<b>28</b>	<b>FINAL HOOKUPS AND CHECKS</b> .....	<b>51</b>
<b>PRECAUTIONS</b> .....	<b>4</b>	Build the Fuselage Bottom Frame .....	28	Flap and Aileron Control Hookup .....	51
<b>DECISIONS YOU MUST MAKE EARLY IN THE BUILDING SEQUENCE</b> .....	<b>4</b>	Sheet the Fuselage Bottom Frame .....	31	Install Receiver, Battery, and Antenna.....	51
Engine Selection.....	4	Fuel Proof and Paint the interior .....	33	Control Surface Throws .....	52
Flaps.....	4	Install Pushrods and Servos.....	33	Balance your Model.....	52
Operational Lighting .....	5	Frame the Fuselage Top.....	33		
Notes for Competition-Minded Modelers .....	5	Install Nose Gear Steering .....	35	<b>PRE-FLIGHT</b> .....	<b>53</b>
Documentation .....	5	Install the Engine and Tank .....	36		
Other Items Required .....	5	1.20 Engine Servo Option .....	37	<b>AMA SAFETY CODE</b> .....	<b>54</b>
Suggested Supplies and Tools .....	5	Attach the Stab and Fin .....	37		
Common Abbreviations .....	6	Tips for Silver Soldering .....	39	<b>FLYING</b> .....	<b>54</b>
Metric Conversions.....	6	Complete the Fuse Top .....	39	Balance the Propeller .....	54
Types of Wood.....	6	Mount the Wing to the Fuselage.....	41	Takeoff .....	55
				Flying .....	55
<b>DIE-CUT PATTERNS</b> .....	<b>7&amp;8</b>	<b>HINGE THE CONTROL SURFACES</b> .....	<b>42</b>	Landing.....	55
Get Ready to Build .....	9	Hinge the Elevator, Rudder & Ailerons .....	42		
				<b>TWO-VIEW DRAWING</b> .....	<b>Back Cover</b>
<b>BUILD THE TAIL SURFACES</b> .....	<b>9</b>	<b>FUSELAGE FINISHING TOUCHES</b> .....	<b>43</b>		
Build the Horizontal Stabilizer.....	9	Assemble the Cowl.....	44		
Tips for Making Wing & Stab Skins .....	10	Fit the Cowl to the Fuse and Engine .....	44		
Build the Elevators.....	12	Assemble and Install Wheel Pants .....	45		
Build the Fin.....	14	Install Wing Struts and Fairings.....	47		
Build the Rudder.....	15				
		<b>FINISHING</b> .....	<b>47</b>		
<b>BUILD THE WING</b> .....	<b>16</b>	Final Sanding.....	47		
Build the Center Section.....	16	Fuel Proofing .....	47		
Build Outer Wing Panels .....	18	Balance the Airplane Laterally.....	47		
Prepare the Polyhedral Braces.....	20	Cover the Structure with MonoKote® .....	48		
Join the Wing Panels.....	21	Painting.....	49		
Sheet the Bottom of the Wing.....	22	Draw Door and Hatch Outlines .....	49		
Prepare the Wing Panels for the Flaps.....	24	Apply the Decals.....	49		
Sheet the Top of the Wing .....	24	Cockpit Finishing .....	50		
Wing Completion .....	25	Install Control Surface Corrugations.....	50		
Build the Flaps.....	27				
Fit the Flaps.....	27				

**PROTECT YOUR MODEL,  
YOURSELF & OTHERS –  
FOLLOW THIS IMPOR-  
TANT  
SAFETY PRECAUTION**

Your Cessna 182 Skylane is not a toy, but rather a sophisticated, working model that functions very much like an actual airplane.

Because of its realistic performance, the Skylane, if not assembled and operated correctly, could possibly cause injury to yourself or spectators and damage property.

**To make your R/C modeling experience totally enjoyable, we recommend that you get experienced, knowledgeable help with assembly and during your first flights.** You'll learn faster and avoid risking your model before you're truly ready to solo. Your local hobby shop has information about flying clubs in your area whose membership includes qualified instructors.

You can also contact the national Academy of Model Aeronautics (AMA), which has more than 2,500 chartered clubs across the country. Instructor training programs and insured newcomer training are available through any one of them.

Contact the AMA at the address or toll-free phone number below.

**Academy of Model Aeronautics**  
5151 East Memorial Drive  
Muncie, IN 47302  
(800) 435-9262

## INTRODUCTION

Thank you for purchasing the **Top Flite GOLD EDITION Cessna 182 Skylane**.

The Top Flite 182 Skylane makes an excellent sport scale competition aircraft. Its large size and accurate scale outline afford the opportunity for the scale builder to *go all out* with the surface details and finish. With the abundance of Cessna 182s in airports around the world, finding a full-scale plane to document and duplicate for competition shouldn't present a problem.

The Top Flite Cessna 182 has demonstrated flight characteristics rarely found in any scale model. Anyone who has mastered a trainer with ailerons should be able to fly this model with a high level of proficiency from the first flight. It handles very much like a full-size Cessna—*smooth and predictable*. Our 11 pound prototype was flown with an O. S. .61SF 2-stroke and 12 x 6 prop throughout much of its flight testing. This combination provided more than ample power for all normal flight maneuvers and aerobatics.

Because of its 81" wingspan, the Top Flite Cessna 182 is eligible to be entered at IMAA\* events. In order to be IMAA-legal, some of the control components and hardware may need to be replaced to conform to Giant Scale rules even though *this* model does not require heavy duty hookups.

The cockpit interior has been engineered to be free of obstructions, servos and pushrods. This feature provides the modeler with the space to build a scale interior with front and rear seats, baggage compartment, and full figure pilot.

Simulated Fowler Flaps allow beautifully slow approaches and landings. Half flap takeoffs require less ground roll to rotate and allow a fairly steep climb over obstacles.

The nose of this model has been engineered to allow you to completely hide most 2-stroke engines in the recommended range. A Top Flite 2-stroke muffler with headers to fit several of the recommended engines have been specifically designed for and tested in the Skylane and other Top Flite models. This muffler provides good sound reduction while fitting entirely inside the cowling. More information on the recommended engines and related items can be found in the **Engine Selection Section** on page 4.

\* IMAA is the *International Miniature Aircraft Association*, an organization that promotes non-competitive flying of giant scale models.

### IMAA

International Miniature Aircraft Association  
205 S. Hilldale Road  
Salina, KS 67401

**Please inspect all parts carefully before starting to build! If any parts are missing, broken or defective, or if you have any questions about building or flying this model, please call us at (217) 398-8970 and we'll be glad to help. If you are calling for replacement parts, please look up the part numbers and the kit identification number (stamped on the end of the carton) and have them ready when calling.**

# PRECAUTIONS

1. You must build the plane **according to the plans and instructions**. Do not alter or modify the model, as doing so may result in an unsafe or unflyable model. **In a few cases the plans and instructions may differ slightly from the photos. In those instances you should assume the plans and written instructions are correct.**
2. You must take time to **build straight, true and strong**.
3. You must use a proper R/C **radio** that is in first-class condition, a correctly-sized **engine** and correct **components** (fuel tank, wheels, etc.) throughout your building process.
4. You must properly **install** all R/C and other components so that the model operates properly on the ground and in the air.
5. You must **test** the operation of the model before the first and each successive flight to ensure that all equipment is operating, and you must make certain that the model has remained structurally sound. Be sure to check external nylon clevises often and replace them if they show signs of wear.
6. You must **fly** the model **only with the competent help** of a well experienced R/C pilot if you are not already an experienced R/C pilot at this time.

**NOTE:** We, as the kit manufacturer, can provide you with a top quality kit and great instructions, but ultimately the quality and flyability of your finished model depends on how **you** build it; therefore, we cannot in any way guarantee the performance of your completed model, and no representations are expressed or implied as to the performance or safety of your completed model.

**Remember: Take your time and follow directions to end up with a well-built model that is straight and true.**

## DECISIONS YOU MUST MAKE EARLY IN THE BUILDING SEQUENCE

### ENGINE SELECTION

**The recommended engine size range is as follows:**

- .60 to .91 cu. in. **2-stroke**
- .90 to 1.20 cu. in. **4-stroke**

The Cessna 182 Skylane will fly **well** with any of the recommended engines. The 4-stroke engines and most .90 2-stroke engines will turn a larger prop at lower rpm. This is often desirable for scale realism. Many .60 2-stroke engines produce about as much horsepower as the popular .90 2-stroke engines. Both are fine choices for the Skylane. If you use a .60 2-stroke, a Schnuerle-ported engine is preferred.

The prototype Skylane that weighed 11 pounds with all of the options, including flaps and operational lighting, was flown with an **OS .61 SF. This engine provided excellent performance and more than enough power, even in gusty winds.** Although larger engines can be used to power this model, the extra horsepower is **not** needed.

The included adjustable engine mount will hold a range of engines from .60 2-stroke through 1.20 4-stroke.

A special Top Flite header and muffler are available that will fit inside your cowling. They are primarily designed for 2-stroke engines mounted horizontally, as used on our prototype.

- Header for O.S .61SF (TOPQ7920)
- Header for SuperTigre S61K & S75K (TOPQ7925)
- Muffler for above (TOPQ7916)

### OPTIONAL FLAPS

This model is designed to incorporate scale flaps; however, be assured that **flaps are optional and not necessary** for an excellent flying experience. The only difference is, without flaps the takeoff roll is a little longer and the landing speed is slightly faster.

The flaps are not difficult to assemble, but they do require good craftsmanship if they are to fit well. They add nicely to the model's flight characteristics and scale appearance while causing no bad effects. Only slight trim correction is needed when they are used with the recommended throws. The flaps add drag and lift to the model on landing approaches, which gives the plane a very steady, locked-in feel.

The flaps require one extra channel, a Y-harness, and two standard servos. They are a highly recommended *fun option* for those who wish to install them. More information on the use of the flaps may be found in the “Flying” section.

## OPERATIONAL LIGHTING

We installed an operational lighting system for added realism and scale appearance. If you plan to use a similar system you should route the wiring **before** enclosing the wing and fin. In lieu of installing the actual wires, string can be taped into position for use in pulling the wires through the structure after covering. We used a separate servo connected to the *retract* circuit of the radio (instead of “Y-ing” into the flap servo) to operate the landing lights. The rotating beacon and position lights were connected to a hidden toggle switch. (See *Optional Lighting* in the next section)

## NOTES FOR COMPETITION MINDED MODELERS

If you plan to compete with the trim scheme shown on the box, here are a few things to consider:

The full-size Cessna 182 “Q” Skylane, N735PE, that was modeled for this kit is hangared near Birmingham, Alabama. The 182Q version was manufactured from 1977 through 1980. During this time 2,540 were built. We designed our model from Cessna’s own 1979 3-view drawings for accurate scale outline.

If you plan to enter your Skylane in competition, this kit will qualify for the **Sport Scale** category without any changes. Always work from

photos of a full-size aircraft when finishing your model because that is what you will need for judging documentation. For dimensional accuracy, the Top Flite Cessna 182 is exactly 1:5<sup>1</sup>/<sub>4</sub> scale.

## DOCUMENTATION

Three-view drawings and photo packs of N735PE and other Cessna 182’s are available from:

**Scale Model Research,**  
3114 Yukon Ave, Costa Mesa, CA 92626  
(714) 979-8058

## OTHER ITEMS REQUIRED

- 4 to 6 channel radio with 5 to 7 servos.
- Engine (see page 4)
- Propellers (see engine instructions for recommended sizes).
- 1 or 2 Pilot figures (1/5 scale recommended)
- Fuel Tank (Great Planes® 12 oz. GPMQ4105 recommended)
- 3-1/4” Main Wheels (2) (Dubro 325T)
- 2-3/4” Nose wheel (1) (Dubro 275T)
- (2) 3/16” Wheel Collars (Great Planes GPMQ4308 recommended)
- Top Flite Super MonoKote® (3-4 rolls, See *Finishing* section)
- Paint (see *Finishing* section)
- 24” Silicone Fuel Tubing (Great Planes GPMQ4131 recommended)
- 1/2” Latex Foam Rubber Padding (Hobbico® HCAQ1050 recommended)
- 2-1/4” Spinner (Top Flite TOPQ5405 recommended)

## Optional:

- Fuel Filler Valve (Great Planes GPMQ4160 recommended)
- (6) Large Hinge Points (for flaps) (Robart #309 recommended)
- Top Flite Header & In-Cowl Muffler (See page 4 for more information)
- Ram #03 Landing Lights (RAMQ2303)
- Ram #04 Rotating Beacon (RAMQ2304)
- Ram #14 Big Airplane Navigation Lights (RAMQ2314)
- Robart Robostrut Nosegear (ROBQ1707) **or**
- Robart Front Wheel Strut Cover (ROBQ2703)

## SUGGESTED SUPPLIES AND TOOLS

*We recommend Top Flite Supreme™ CAs and Epoxies*

- (2) 2 oz. CA (Thin) (TOPR1003)
- (2) 2 oz. CA+(Medium) (TOPR1008)
- 1 oz. CA- (Thick) (TOPR1011)
- 6-Minute Epoxy (TOPR1040)
- 30-Minute Epoxy (TOPR1043)
- Titebond® Wood Glue (optional)
- Hand or Electric Drill
- Drill Bits: 1/16”, 3/32”, 1/8”, 5/32”, 3/16”, 13/64”, 1/4”, 15/64”
- Soldering Iron and Silver Solder
- Sealing Iron (Top Flite)
- Heat Gun (Top Flite)
- Hobby Saw (X-ACTO® Razor Saw)
- Hobby Knife, #11 Blades
- Razor Plane (Master Airscrew)
- Pliers
- Screwdrivers (Phillips and flatblade)
- Round file (or similar tool)
- T-Pins (short & long)
- String
- Straightedge with scale

- Nylon Strapping Tape  
(required for bending sheeting)
- Masking Tape (required for construction)
- Sandpaper (coarse, medium, fine grit)\*
- T-Bar Sanding Block (or similar)
- Chalk Stick (local drug store)
- Waxed Paper
- Thin Cardstock or a File Folder
- Lightweight Balsa Filler, such as Hobbico HobbyLite™
- 1/4-20 and 8-32 Taps and Tap Wrench
- Isopropyl Rubbing Alcohol (70%)
- Auto Body Filler (Bondo® or similar)
- Dremel® Moto-Tool® or similar (optional)

**\*NOTE:** On our workbench, we have four 11" T-Bar sanders, equipped with #50, #80, #150 and #220-grit sandpaper. This setup is all that is required for almost any sanding task. Custom sanding blocks can be made from balsa for sanding hard to reach spots. We also keep some #320-grit wet-or-dry sandpaper handy for finish sanding before covering.

### COMMON ABBREVIATIONS USED IN THIS BOOK AND ON THE PLANS:

- Deg = Degrees
- Elev = Elevator
- Fuse = Fuselage
- LE = Leading Edge (front)
- LG = Landing Gear
- Lt = Left
- Ply = Plywood
- Rt = Right
- Stab = Stabilizer
- TE = Trailing Edge (rear)
- " = Inches

### Metric Conversion Chart

Inches x 25.4 = mm (conversion factor)

1/64"	=	.4 mm
1/32"	=	.8 mm
1/16"	=	1.6 mm
3/32"	=	2.4 mm
1/8"	=	3.2 mm
5/32"	=	4.0 mm
3/16"	=	4.8 mm
1/4"	=	6.4 mm
3/8"	=	9.5 mm
1/2"	=	12.7 mm
5/8"	=	15.9 mm
3/4"	=	19.0 mm
1"	=	25.4 mm
2"	=	50.8 mm
3"	=	76.2 mm
6"	=	152.4 mm
12"	=	304.8 mm
18"	=	457.2 mm
21"	=	533.4 mm
24"	=	609.6 mm
30"	=	762.0 mm
36"	=	914.4 mm

### TYPES OF WOOD

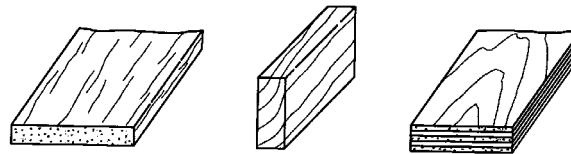

**BALSA**

**BASSWOOD**

**PLYWOOD**

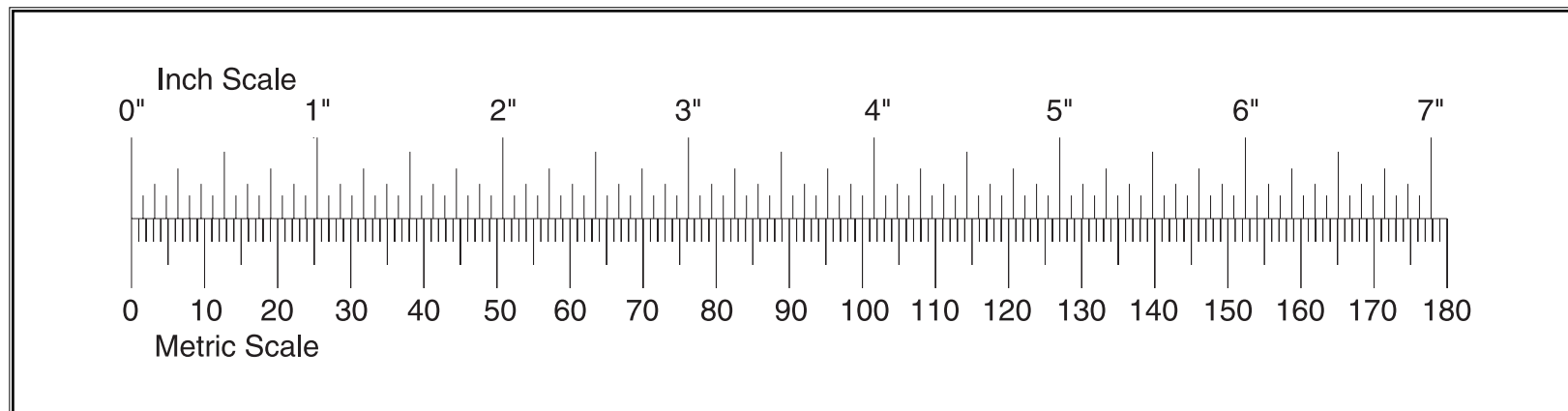

# DIE-CUT PATTERNS

**CES6F01** **2 REQ.**

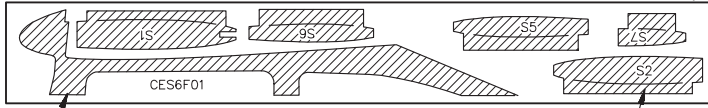

**CABIN SIDE TOP** **3/32" X 3" X 18" Balsa**

**CES6F02** **2 REQ.**

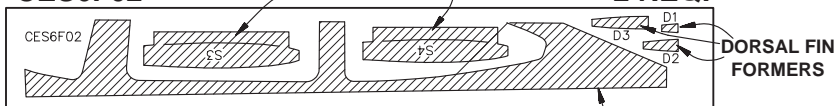

**3/32" X 3" X 21" Balsa** **CABIN SIDE BOTTOM**

**CES6F03** **2 REQ.**

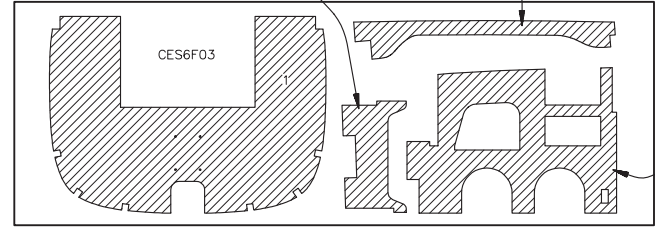

**1/8" X 6-5/8" X 19" PLY**

**CES6F04** **1 REQ.**

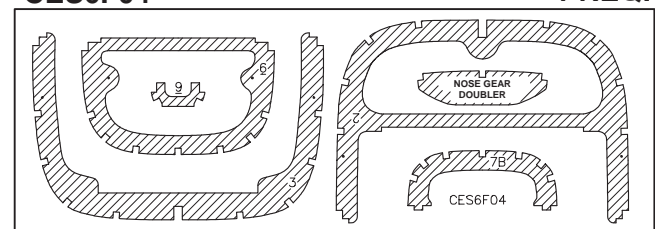

**1/8" X 6-5/8" X 19" PLY**

**CES6S02** **1 REQ.**

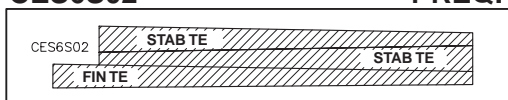

**1/4" X 2-3/4" X 15" Balsa**

**CES6F05** **1 REQ.**

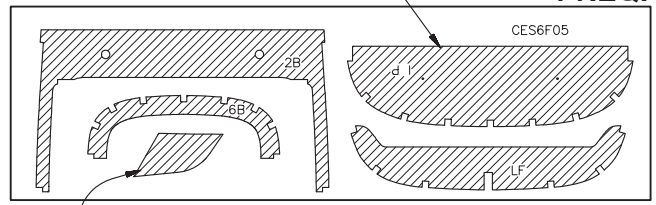

**1/8" X 5-3/4" X 19" PLY**

**CES6F06** **1 REQ.**

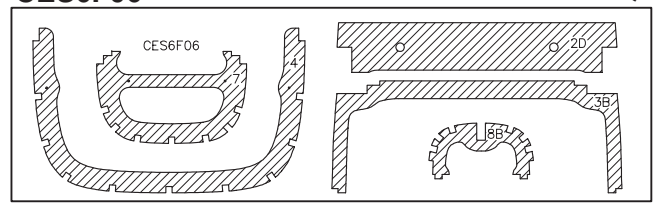

**1/8" X 5-3/4" X 19" PLY**

**CES6F07** **1 REQ.**

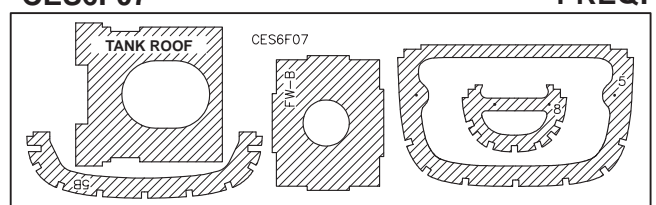

**1/8" X 5-3/4" X 19" PLY**

**CES6F08** **2 REQ.**

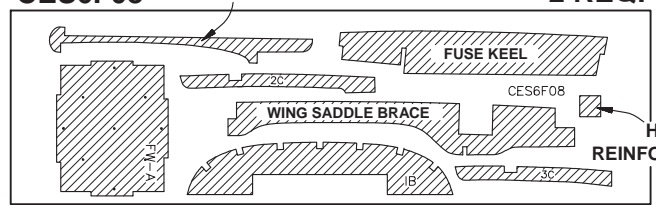

**1/8" X 5-3/4" X 19" PLY**

# DIE-CUT PATTERNS

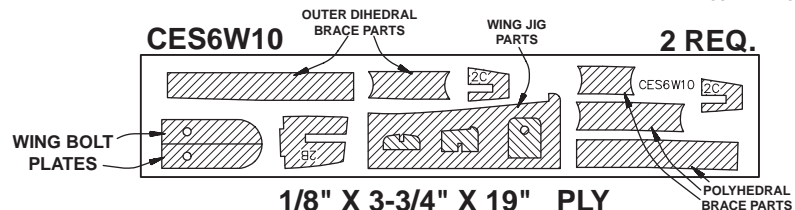
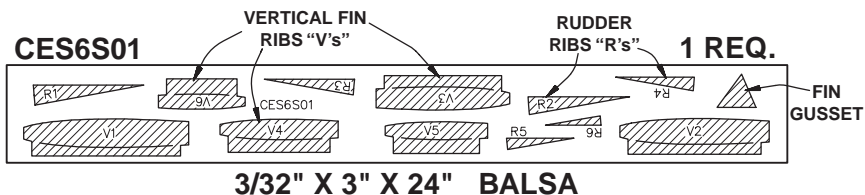
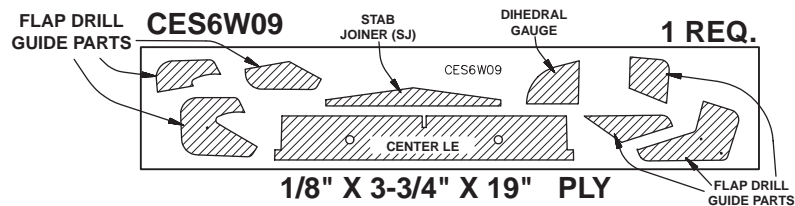
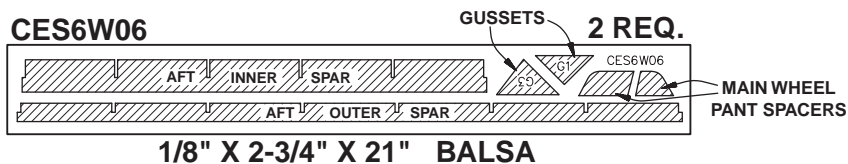
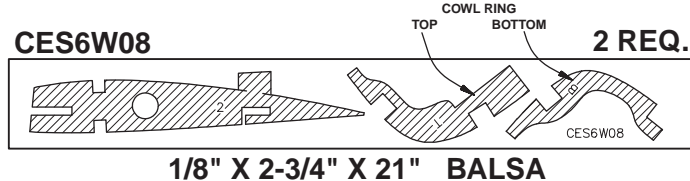
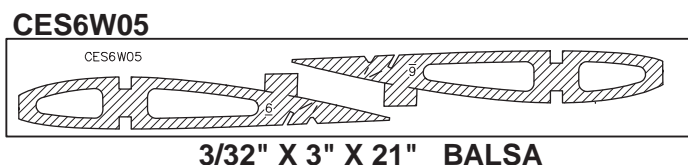
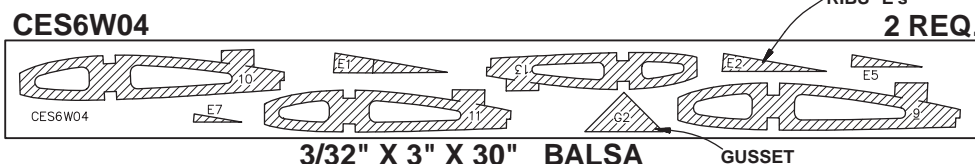
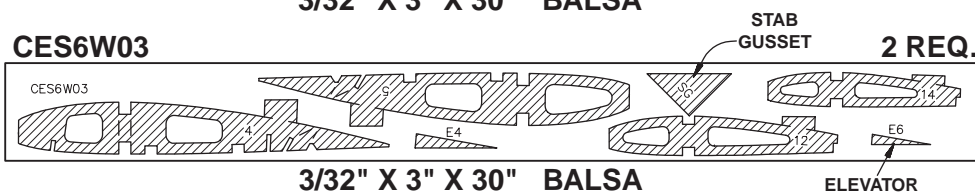
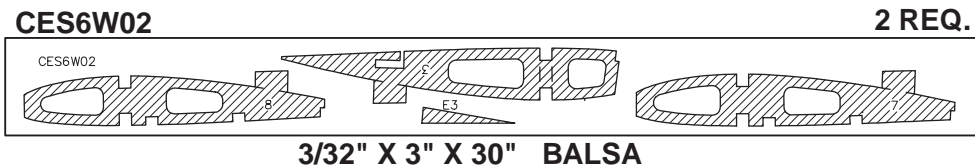
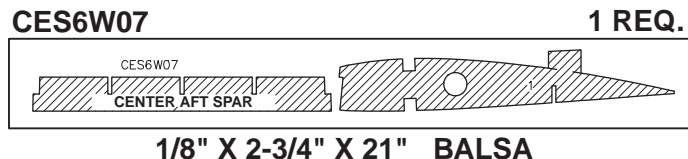
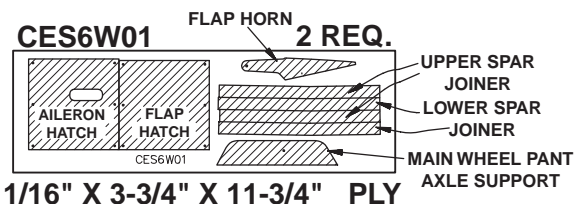

## Get ready to build

1. Unroll the plan sheets. Re-roll the plans inside-out to make them lie flat.

2. Remove all parts from the box. As you do, figure out the name of each part by comparing it with the plans and the parts list included with this kit. Using a felt tip or ball point pen, lightly write the part **name** or **size** on each piece to avoid confusion later. Use the die-cut patterns shown on pages 7 and 8 to identify the die-cut parts and mark them **before** removing them from the sheet. Save all scraps. If any of the die-cut parts are difficult to punch out, do not force them! Instead, cut around the parts with a hobby knife. After punching out the die-cut parts, use your T-Bar or sanding block to **lightly** sand the edges to remove any die-cutting irregularities.

3. As you identify and mark the parts, separate them into groups, such as **fuse** (fuselage), **wing**, **fin**, **stab** (stabilizer), and **hardware**.



Zipper-top food storage bags are a handy way to store your small parts as you sort, identify, and separate them into sub-assemblies.

## BUILD THE TAIL SURFACES

### Build the horizontal stabilizer

1. Work on a flat surface over the plans covered with waxed paper. Refer to the plans to identify the parts and their locations. *The plans may be cut apart if space is a problem.*

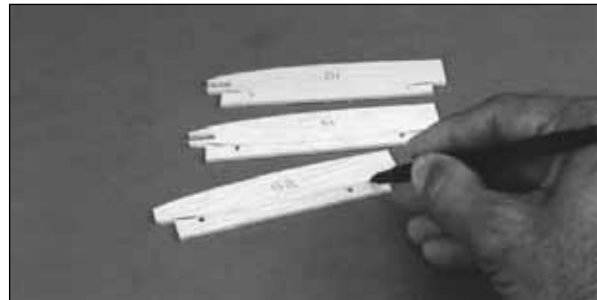

2. Punch out both sets of the die-cut 3/32" balsa ribs **S-1** through **S-7**. There is a jig tab on the bottom edge of each of these ribs. If any of these break off, carefully glue them back on with a drop of thin CA. Lightly sand any imperfections. You may need to finish cutting the notch in the forward portion of **S-1** for the **Stab Joiner (SJ)** with a knife. Use a pen to mark the extensions of the bottom edge of the ribs across the fore and aft ends of the jig tabs. These marks will help when you trim off the jig tabs later.

3. The stab **Trailing Edges (S)** are die-cut from 1/4" balsa. Since some crushing may occur during die-cutting wood of this thickness, they are supplied slightly long and can be trimmed. True up all edges of these pieces with a T-bar.



4. Cut the stab **Leading Edges (LE's)** to length from the 1/4" x 15" tapered balsa stock. *They should be about 1/4" longer than the length shown on the plans for the stab LE.*

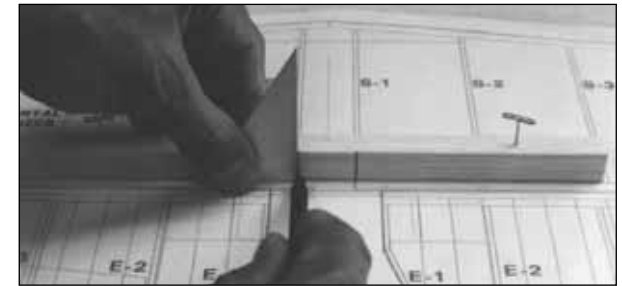

5. Center the 1/2" x 5/8" x 9-3/4" balsa **TE Center Brace** over the plans and pin it in place. Use a triangle and pen to mark the inboard ends of the Stab TE. Remove the TE Center Brace from the building board.

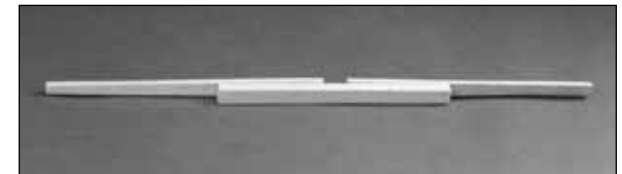

6. Apply thick CA to one half of the TE Center Brace, then align the inboard end of a **Stab TE** with the reference line you just drew. Glue the TE Center Brace in position. **The TE Center Brace must be centered on the Stab TE.** Repeat this operation for the other half of the TE, then use long T-pins to pin the assembly over the plans.

**NOTE: Position the outboard ends of the TE about 1/2" above the board. The TE Center Brace should be raised about 3/8". (See next photo.)**



□ □ 7. Pin the **left and right S-3** and **S-6** ribs to the building board over their locations on the plans. Adjust the height of the Stab TE to align it evenly with the aft edge of the ribs. Glue the ribs to the Stab TE and to the TE Center Brace with thin CA.



□ □ 8. Align and glue all of the remaining Stab ribs to the TE.



Lightly sand a bevel along the front edge of the Stab **ribs** to match the sweep angle of the LE. This will give you a better fit and a stronger glue joint.



□ □ 9. Glue the two die-cut 3/32" balsa **Stab Gussets** into the junction of S-6 and the Stab TE. The Gussets should be centered between the top and bottom of the ribs and Stab TE. Glue the die-cut 1/8" ply **Forward Stab Brace** into the slots in the S-1 ribs and to the inside edges of the S-2 ribs.



□ □ 10. Sand one end of two shaped balsa Stab LE's to exactly match the angle at the center of the Stab. *Leave the outboard ends long for the time being.* Center the LE (vertically) on the front of the ribs, then tack glue the Stab LE's to the forward edge of ribs S-1 and S-6 and to the Forward Stab Brace (this will align the LE). Glue the remaining ribs to the LE, checking for straightness as you proceed.

□ □ 11. Glue both S-7 ribs to the Stab LE.

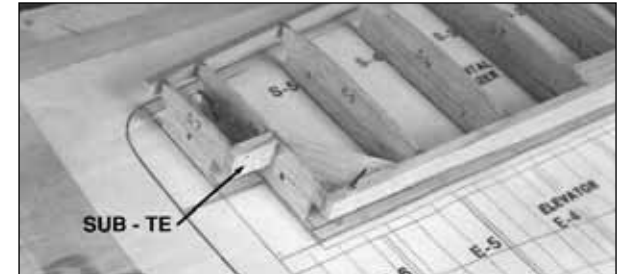

□ □ 12. Glue the 1/4" x 1/2" x 7/8" balsa **Stab Sub TE** to the aft edge of S-7 and to the side of S-6. Make sure that the Stab Sub TE is positioned exactly 90 degrees to S-6.

□ □ 13. Trim the Stab LE's flush with the S-7's. **Reinforce all of the joints with medium CA.** Sand the tips of the LE, sub TE, and TE flush with S-7 and S-6.

□ □ 14. Remove the pins, then lightly sand the top surface of the stab frame to blend all parts and remove any excess CA. **Take care not to change the shape of the airfoil.**



#### HOW TO MAKE WING AND STAB SKINS

A. Wherever practical, pre-join the balsa sheets to make a "skin" before attaching them to the structure.

B. Many modelers like to sort the wood so they can put the **best** wood with the most even grain structure on the top of the wing and stab.

C. Make your skin larger than needed to allow

for misalignment. On a large surface such as the wing, 3/8" extra is suggested.

#### D. To make skins, the following steps are suggested:

1. True up the edges of the sheets with a metal straightedge and a sharp knife or a "T-Bar" sanding block.

2. Test-fit the sheets together to make sure they match well.

3. METHOD "A": Edge glue the sheets together with thin CA, over a flat surface covered with waxed paper. A quick wipe of the joint with a fresh paper towel will remove excess glue and make sanding easier. Mark the poorest surface to identify it as the "inside" surface.

METHOD "B": Edge glue the sheets together with Titebond® wood glue. (Titebond is easier to sand and won't leave a ridge at the seam, as CA is prone to do.) Smear the glue lightly along an edge with your finger, then join the sheets over a flat (waxed paper covered) building board. Pin the sheets to the board to hold them together. Wipe off any excess glue before it dries.

4. Place the skin on a large flat surface and sand it with a large flat sanding block and fresh, sharp 220 paper. Use light pressure and a brisk **circular** motion.

5. Trim the perimeter of the sheet to even things out.

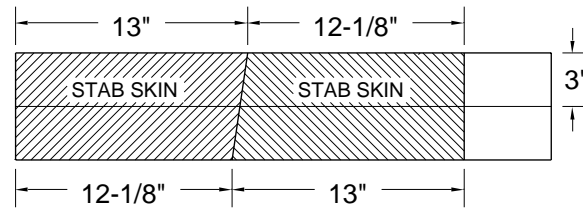

□ □ 15. Make two 6"x 30" **stab skin planks** from four 1/16" x 3" x 30" balsa sheets. From these planks, cut four stab skins. See the sketch for the proper layout on the wood. Refer to the plans for the exact shapes and sizes, but remember to make the skins slightly oversize.

□ □ 16. Pin the stab structure to your building surface using pins only at the tips and diagonally under the LE & TE. **Make sure that the jig tabs are flat on the building surface.** Don't hide the pins under the skin.



□ □ 17. Use the off-cut 1/16" material from the skin planks to make a 1" wide cross-grain strip to fit between the S-1's from the LE to the TE. Glue the strip in place between the ribs, flush with the top edge.

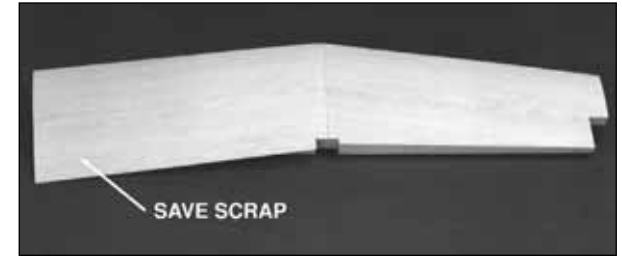

□ □ 18. Test-fit the skins over the stab frame. Make sure the skins meet flush at the center. Adjust them with a sanding block if necessary. Apply an even bead of medium or thick CA to the upward-facing edges on one side of the frame. Place a skin in its proper position and press it firmly down until the glue has set. Repeat this step for the other top skin. Trim off the excess balsa, but save any big scraps for use when making the elevators.

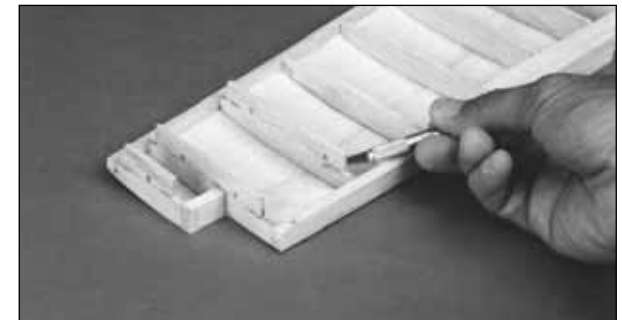

□ □ 19. Remove the stab from the building board. Trim off the jig tabs with a sharp knife. Trim and blend the LE and TE to the ribs as you did before. Check all glue joints, adding glue as necessary.

□ □ 20. Cut another 1" wide cross-grain strip from 1/16" x 6" off-cut balsa sheeting and glue it between the two S-1 ribs flush with their **bottom edges**.

□ □ 21. It's **important** to get a good glue bond between the stab frame and the bottom stab skins. Apply a **heavy** bead of medium or thick

CA to all of the *upward facing* edges on one side of the stab frame. Place a skin on the frame and hold it in place with your hands until the glue sets. Repeat this for the other bottom skin. **Be careful not to bend or twist the stab during this step.**

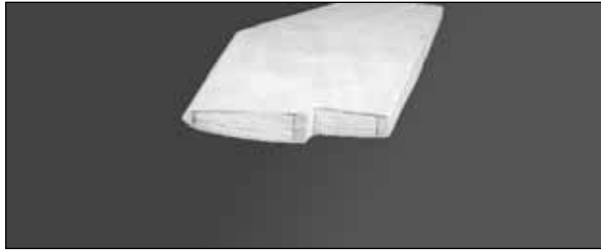

□ □ 22. Trim off the excess balsa from around the perimeter of the stab. True up the ends of the stab with a sanding block. Round the LE of the stab to match the **cross section** on the plan.

### Build the elevators

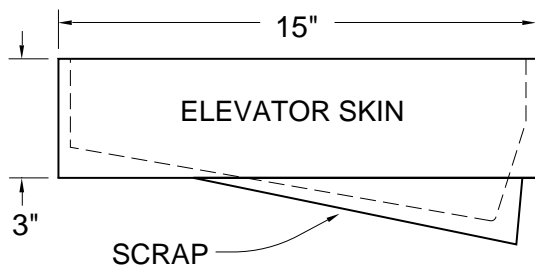

□ □ 1. Cut two 1/16" x 3" x 36" balsa sheets to make four 15" long sheets. Refer to the sketch and the elevator plans, then glue the leftover balsa "wedges" that you cut from the stab skins to the 15" sheets. These joined sheets will be used to make the top and bottom **Elevator skins**.

□ □ 2. Use the **pattern on the plans** to cut four Elevator skins. Sort the skins so that the best surfaces will be facing outward, and on the top.

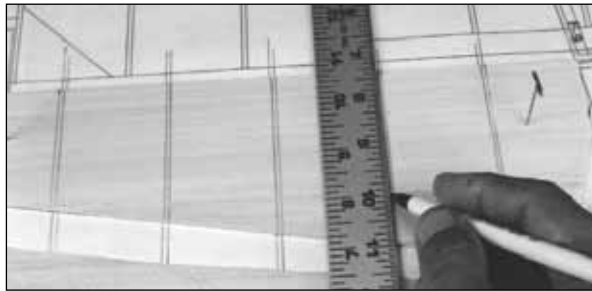

□ □ 3. Cover the elevator plan with waxed paper, then pin a skin in position. Use the "tic" marks on the plan to draw the rib locations on the skin.

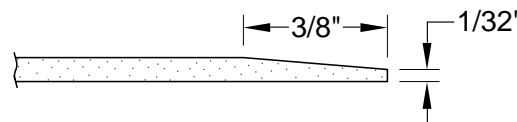

□ □ 4. Draw a line along the length of the skin's TE 3/8" in from the edge. Remove the skin from the building board, then holding it along the edge of your work bench, sand a taper from the line towards the TE so that the TE will be approximately 1/32" thick.

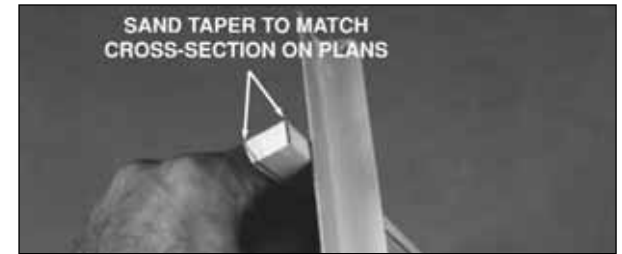

□ □ 5. Locate the 3/8" x 3/4" x 11-5/8" shaped balsa **Elevator LE**. Draw two lines, 1/32" in from each edge, on one side of the LE as shown in the photo. Use the lines as a reference to taper the top and bottom of the LE toward the elevator TE with a T-bar sander. **Proceed carefully, checking your progress against the height of the elevator ribs at each location.**



□ □ 6. Glue the LE to the inside surface of the the elevator skin, flush with the forward edge of the skin. Glue the 3/32" die-cut balsa ribs (**E-1** through **E-7**) to the skin and to the LE with thin CA.



□ □ 7. Test fit a 1/2" x 1" x 1-5/8" balsa **Torque Rod** block between ribs E-1 and E-2. Sand the ends, if necessary, for a good fit. Sand a slight angle on the forward edge of the Torque Rod

block (the one that will contact the elevator's LE) to match the angle of the LE. Glue the Torque Rod block in position when you are satisfied with the fit.

☐☐ 8. Carefully sand the top of the Torque Rod block flush with the taper of the ribs.

☐☐ 9. Mark and sand the *inside* TE of an elevator skin as you did in step 4. Apply a bead of thick CA to LE, TE, and all ribs, then glue the top skin into position. Hold the assembly flat until the CA cures.

☐☐ 10. True up all edges with a T-bar or sanding block.

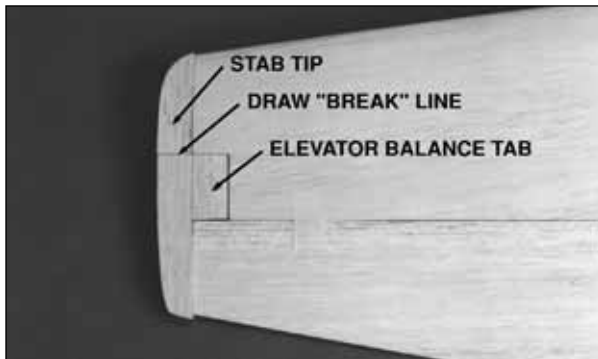

☐☐ 11. Test fit the Stab, Elevator, 5/8" x 7/8" x 6-1/2" shaped balsa **Stab Tip**, and the 5/8" x 27/32" x 1-9/16" balsa **Elevator Balance Tab** together. Make any adjustments with light sanding. Mark the "break" between the Stab and the Elevator on the Stab Tip. Cut the Stab Tip apart along this line.

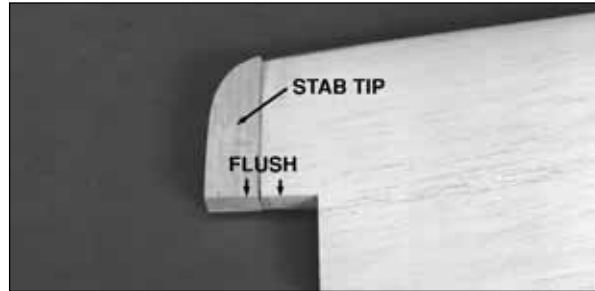

☐☐ 12. Glue the forward balsa **Stab Tips** in position.

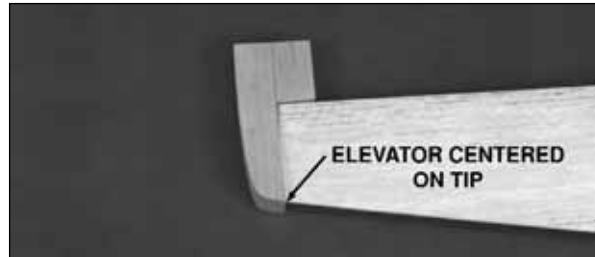

☐☐ 13. Glue the Elevator Balance Tab flush with the Elevator Tip. **Center** the Stab Tip on the outboard end of the Elevator, before using thick CA to glue in place. Make sure that both the Elevator LE and TE are centered before the CA cures.

☐☐ 14. Tape the elevator assembly to the Stab. Make sure that the Stab Tip and Elevator Balance Tab are flush along the outside edge. There should be a 1/32"-1/16" gap between the Elevator Balance Tab and the Stab. If not, use your T-bar sander to correct the problem by alternately sanding the inside edges of the Elevator Balance Tab and the Stab.

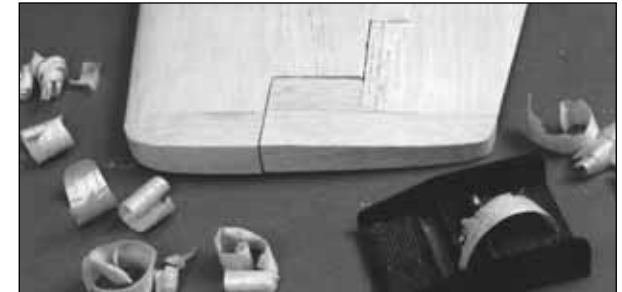

☐☐ 15. When satisfied with the fit, use a razor plane and sanding block to shape the Stab Tip to blend with the Elevator and Stab.



☐☐ 16. Sand a radius around the Balance Tab as shown in the photo.



☐☐ 17. Sand a radius around the outboard edges of the Stab and Elevator Tip.

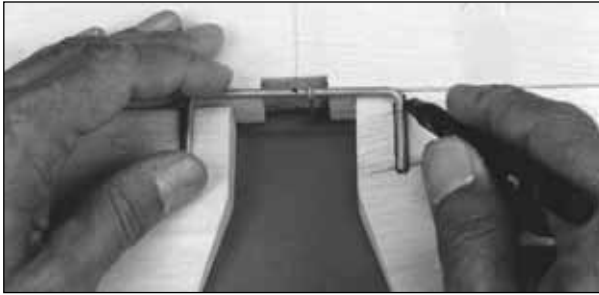

❑ 18. Tape the Elevators to the Stab making sure that you have the correct clearance around the Balance Tabs. Hold the bent 1/8" **Elevator Joiner Wire and Horn** up to the Elevator and mark the location of the Joiner Wire holes that will be perpendicular to the hinge line (see the plans for the joiner location).

**NOTE: The Elevator Horn is off-center. When looking at the top surface of the Stab, the Horn will be to the right of Stab center.**

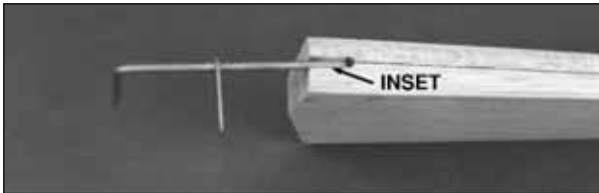

❑ 19. Drill 9/64" holes in the elevators for the Joiner wire. Cut slots inboard of the holes to allow the wire to be inset into the elevators, flush with the LE. Sand the **Elevator LE** to a "V" shape to allow for Elevator travel — refer to the plans for the correct angle.

❑ 20. Test-fit, but do not glue the joiner wire into the Elevators. Check to see that the Elevators align with each other properly and that they fit the Stab without binding. Make adjustments by **removing** the Joiner Wire and then bending it, if required.

## Build the fin

- ❑ 1. Cover the Fin/Rudder section of the plans with waxed paper.
- ❑ 2. Punch out the die-cut 3/32" balsa ribs **V-1** through **V-6**. Be sure to preserve their jig tabs.

**NOTE: If you plan to install an operational beacon light on top of the Fin drill a 3/16" hole through the center (front to back, top to bottom) of each rib. This hole will provide a passage for the wiring.**

- ❑ 3. Cut a 15" length of the tapered 1/4" balsa **Stabilizer/Fin LE** stock to **match the plans exactly**, as the length of the LE sets the angle of the fin. *Notice that the Fin LE fits into a notch on top of F-8.*
- ❑ 4. Punch out the die-cut 1/4" balsa **Fin TE** and lightly sand the edges to touch them up. Sand (or cut) the tips to match the sweep angle as shown on the plans.

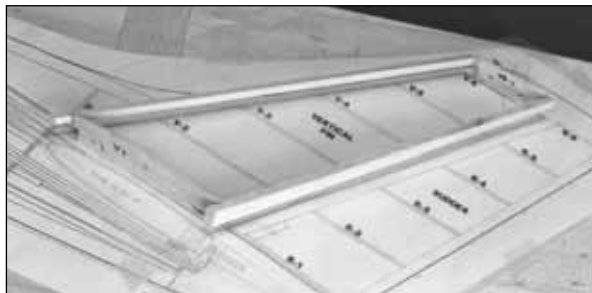

- ❑ 5. Sand an angle on the ends of each rib to match the sweep angle of the LE and TE. Pin ribs **V-1** and **V-6** to the building board over their proper locations. Center the LE on the front of the ribs and glue it in place. Center the Fin TE on the aft edge of the ribs and glue it in place.



- ❑ 6. Put ribs **V-2** through **V-5** into their places and glue them to the LE and TE. **Remember, all jig tabs should contact the work surface.**

- ❑ 7. Glue the die-cut 3/32" balsa **Fin Gusset** into the corner of V-6 and the Trailing Edge.

- ❑ 8. Apply extra CA+ glue to any joints that do not appear to be well glued.

- ❑ 9. Blend the LE to match the ribs on the upward facing (left) fin side. Sand the TE, if necessary, to blend smoothly with the ribs.

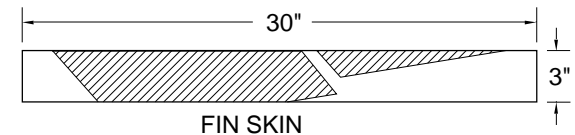

- ❑ 10. Make a skin for each side of the fin using 1/16" x 3" x 30" balsa sheet. Leave excess balsa on one edge of the skin so it **overhangs past V-1 about 5/8"**; this will allow fitting to the stab later. With the structure flat on the table, glue on the left (upward-facing) skin.

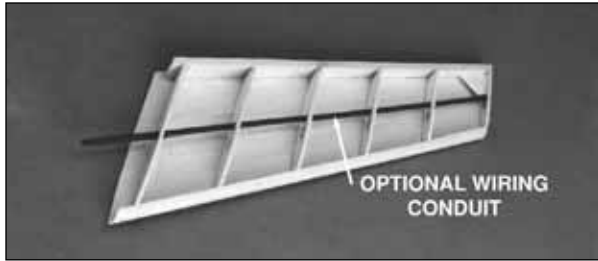

- ❑ 11. Remove the fin from the building board and trim off the jig tabs. Blend the LE and TE to the ribs on the right side of the fin.

**NOTE: If you plan to route wiring for a beacon through the fin, install a 15" length of outer pushrod tube (not supplied) through the 3/16" holes you drilled in step #2. Glue it in position with medium CA, leaving the excess tube protruding from V-1.**

- ❑ 12. Use medium or thick CA to glue on the right side skin. Be sure to get a good bond between the ribs and the skin.

- ❑ 13. True up the edges of the fin sheeting with a sanding block. Shape the LE to match the cross section on the plans. Don't trim the bottom edge of the sheeting at this time.



- ❑ 14. Glue the shaped 3/4" balsa **Fin Tip** to the top of the fin. Shaping should be done later, with the fin taped to the rudder.

**NOTE: If adding a beacon light, drill a hole through the top of the Fin Tip that aligns with the wiring tube before you glue it in place.**

## Build the rudder

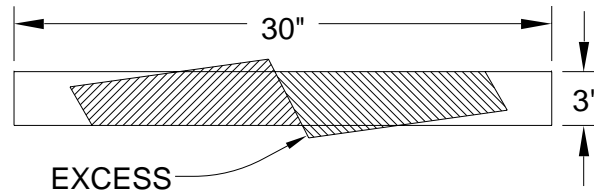

- ❑ 1. Use one 1/16" x 3" x 30" balsa sheet to make two **rudder skins**, using the rudder skin pattern on the wing plan. You will need to edge glue a small wedge shaped piece of sheeting to the TE of the skin to provide the correct width. You should have more than enough material left over from the previous assemblies to accomplish this step.



- ❑ 2. Pin one of the rudder skins to the (wax paper covered) plans and draw the location of each rib using the "tic" marks as a guide. Draw a line the length of the rudder skin, 3/8" in from the aft edge, as you did with the elevators. Remove the rudder skin from the board and taper the aft edge to 1/32". Taper the aft edge of the other rudder skin to 1/32". (See next photo.)



- ❑ 3. Locate the 3/8" x 3/4" x 12" tapered balsa **rudder LE**. Cut the tips to match the sweep

angle of the rudder. Lightly sand both sides of the rudder LE to match the angle toward the aft edge of the rudder.

- ❑ 4. Re-pin the rudder skin over the plans. Glue the rudder LE to the surface of the rudder skin, flush with the front edge, using medium CA. The wide end of the rudder LE is at the bottom end of the rudder.



- ❑ 5. Slightly taper the forward edge of the rudder ribs **R-1** through **R-6** to match the sweep angle of the rudder LE, then glue them in position over the location lines that you drew in step #2.

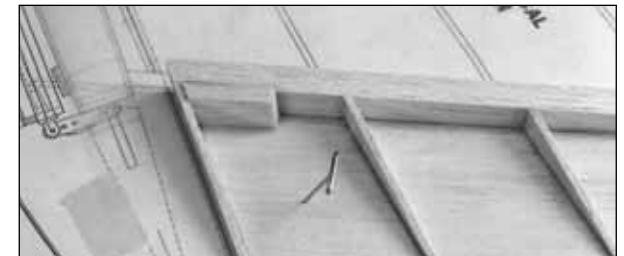

- ❑ 6. Shape one end of the 1/4" x 1/2" x 1-1/4" balsa **Torque Block** to match the angle at the intersection of the rudder LE and R-1. Glue the Torque Block in position when satisfied with the fit.

- ❑ 7. Remove the rudder assembly from the board, then lightly sand the frame to blend all joints. Glue the second rudder skin to the frame with thick CA. To prevent twists, be sure that the assembly is held on a flat surface while the CA cures.

❑ 8. True up all rudder edges with a sanding block.

❑ 9. Position the rudder against the TE of the fin with the top of the rudder **1/32" above the top of the main body of the fin**. Tape the fin and rudder securely together with masking tape.

**NOTE: Before proceeding, study the photo at step 15 to see what you will accomplish in the next six steps.**



❑ 10. Test fit the 3/4" shaped balsa **Rudder Tip** on top of the rudder. It should butt against the Fin Tip squarely, and have a clearance gap of 1/32" above the fin. Make adjustments with a sanding block if needed.

❑ 11. Use thick CA to glue the Rudder Tip to the rudder. Be sure that everything is centered before the CA cures.

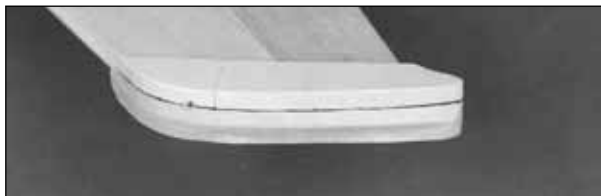

❑ 12. Draw a center reference line across the top of the rudder and fin blocks. A piece of masking tape stretched across the center of the blocks will help you draw a fairly straight line.



❑ 13. Use a razor plane and sanding block to shape the top of the fin and rudder. For **scale realism**, the Rudder Tip should be **slightly wider** than the rudder. Apply 4 layers of masking tape to each side of the rudder to prevent you from removing too much material. The Fin Tip may be sanded flush with the fin. Round off the top 3/8" of both the Fin and Rudder Tips. When the top is shaped and sanded, remove all masking tape.

❑ 14. Draw a centerline on the rudder's LE. Sand a "V" bevel along this line with reference to the plans for the correct angle. Hinging and installation of the torque rod will come later in the assembly process.

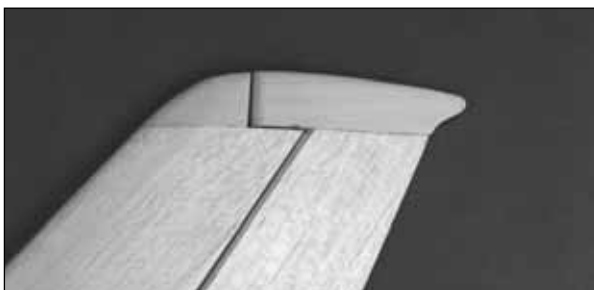

❑ 15. Sand a radius around the forward edge of the Rudder Tip. Hold the fin and rudder together to check the clearance between the Rudder Tip and the Fin Tip. Continue sanding the Rudder Tip radius until there is a 1/32" gap between the two parts.

*Okay, the tail feathers are more or less complete, so by now you are on a roll. The stab looks like the wing for a .20-size model, doesn't it? We'll build the wing next so you'll really have something to impress your buddies when they drop in to see "how the ol' Cessna is doing."*

## BUILD THE WING

**NOTE: The wing panels are built "UPSIDE-DOWN" on the plans. The jig tabs are attached to what is, in the end, the TOP surface of the wing. Since it is the standard convention to show the Top View of the wing, and the wing panels are built upside-down, the LEFT wing panel is built over the RIGHT Wing Top View and vice-versa. This does not present any problems — just be sure to build a left and a right wing.**

### *Build the center section*

❑ 1. Punch out all the die-cut 3/32" and 1/8" balsa wing **Ribs**. Smooth out any imperfections with sandpaper. Be sure to keep the jig tabs attached to the ribs.

❑ 2. Punch out the 1/8" ply **Doublers** and **Wing Bolt Plates**.



❑ 3. Lay out **both sets** of balsa Ribs **W-2** and **W-3**, ply Doublers **W-2B** and **W-2C**, and the ply Wing Bolt Plates **exactly** as shown in the photo. *This way you won't assemble two right or two left sides.* Glue the Doublers to the Ribs and laminate the two pairs of Wing Bolt Plates with 30-Minute Epoxy. After the epoxy has cured, test fit the Wing Bolt Plates into the slots at the aft end of W-2 and W-3. Make slight adjustments to the slots if required, but don't make the fit too loose as this is a critical area for a nice tight bond.

❑ 4. Attach the wing plan (the part showing the center section) to a flat building board and cover it with waxed paper. *Cutting apart the wing panel sections of the plan makes handling easier.*

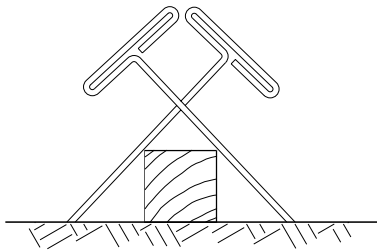

❑ 5. Locate the 3/8" x 3/8" x 20" basswood **Center Spar**. Cut two 9-1/4" pieces from it. Pin one of the 3/8" x 3/8" x 9-1/4" basswood **Center**

**Spars** to the plan using the method shown in the sketch. The Center Spar is a little longer than actually needed to allow for the dihedral angle at W-3. It will be trimmed to size later.

**NOTE: Do not use any CA until step 11.**

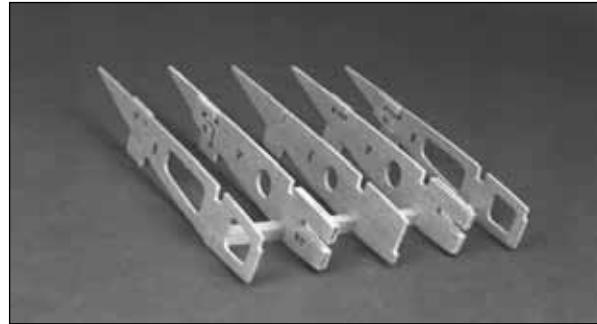

❑ 6. Position rib **W-1** and rib assemblies **W-2** and **W-3** on the Center Spar with the **jig tabs touching the plan**. Be sure that the ply doublers are facing the correct direction.

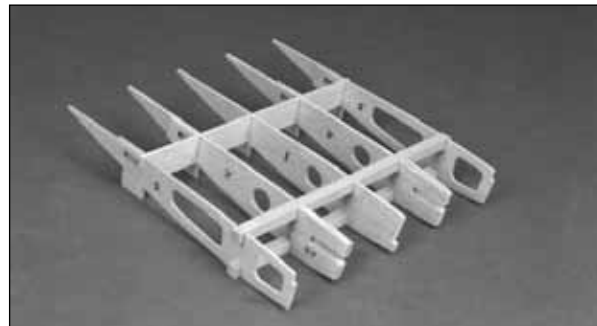

❑ 7. Insert (without gluing) the die-cut 1/8" balsa **Center Aft Spar** into the slots above the jig tabs. Insert the second basswood Center Spar into the forward rib notches. Make sure that both Spars are flush with the upper edge of the ribs.

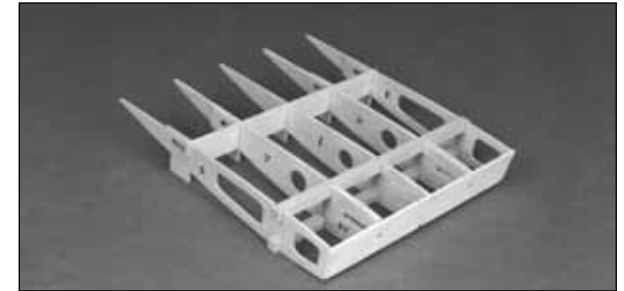

❑ 8. Interlock the 1/8" die-cut ply **Center LE** with the tabs on the LE of ribs W-3 and W-1.

❑ 9. Study the structure. Are all parts over their respective locations on the plans and in alignment? If not, **lightly** use fine grit sandpaper to adjust the fit. **Don't reach for the CA yet!**



❑ 10. Make sure the W-3 ribs are flush with the Aft Spar and the Center LE. Use the 1/8" die-cut ply **Dihedral Gauge** on the **inside** of the W-3 ribs at the forward Spars to set the ribs angle at this location. Hold a straightedge alongside the W-3's to check for straightness.

❑ 11. When you are sure that everything is straight and true (sight down the TE and shim any low ribs with folded paper under the jig tabs) **wick thin CA into every joint**. Hold the LE and W-3's in tight contact for a few seconds to allow the CA to work. Follow the initial gluing by applying a fillet of medium CA around the joints.

*Isn't interlocking construction great?!*

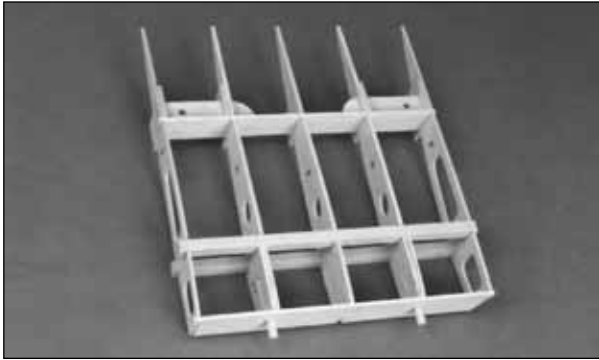

❑ 12. Check the fit of the 1/4" x 1-7/8" **Dowels** and the **Wing Bolt Plates**. Mix up a small batch of 6-Minute Epoxy, then glue these parts in position.

**NOTE: The Wing Bolt Plates must be flush with the outside surface of the W-3's.**

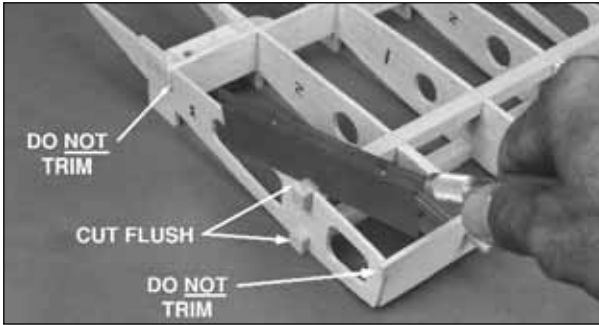

❑ 13. Trim and sand only the basswood Center Spar ends flush with the W-3's. Be sure to **leave the tips of the Center Aft Spar and the Center LE in place** as they will be used when joining the center section to the outer wing panels.

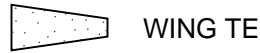

❑ 14. Cut a 9-1/4" length from a 3/32" x 1/2" x 30" tapered balsa **TE** stick. Look at the cross section on the fuse plan for the angle of the TE. Center the TE on the aft edge of the center section ribs, then glue it in place with thin CA. Carefully sand the ends flush with the W-3's.

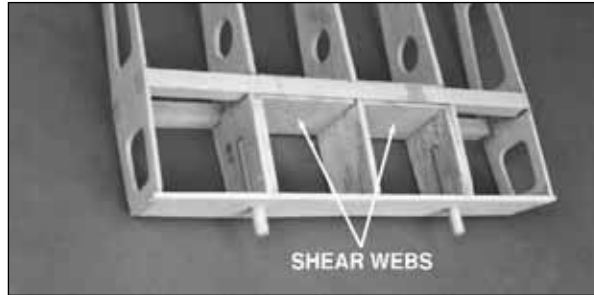

❑ 15. Trim four of the pre-cut 1/16" x 2-3/4" x 1-1/2" **Shear Webs** to fit between the W-1 and W-2 ribs at the forward Center Spars. Glue the Shear Webs to **both sides** of the Center Spars with medium CA

*This completes the wing center section frame, so, zipping right along, let's move on to the outer wing panels.*

## Build outer wing panels

**HINT:** You will speed up the building process if you prepare two "wing panel kits" before you start gluing. We also suggest that you assemble all four spars even though you may only be building one half of the wing at a time.

❑ 1. Place a wing panel plan on your building board and cover it with waxed paper.

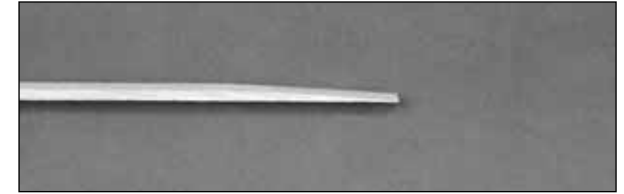

❑ 2. Cut four 1/8" x 3/8" x 24" hard balsa **Outer Spar Doublers** to 22-3/4". Sand a chisel point on **one end** of each piece starting **2"** from the end.

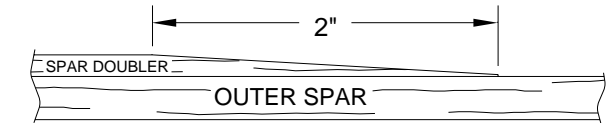

❑ 3. Use medium CA to glue the Outer Spar Doublers to the 1/4" x 3/8" x 36" balsa **Outer Spars**. The un-tapered end of the Outer Spar Doubler must be flush with one end of the Outer Spar.

❑ 4. Pin an **Outer Spar assembly** to the building board at three or four locations using the cross-pinning technique.

**NOTE: Do not apply glue to Ribs until Step 7.**

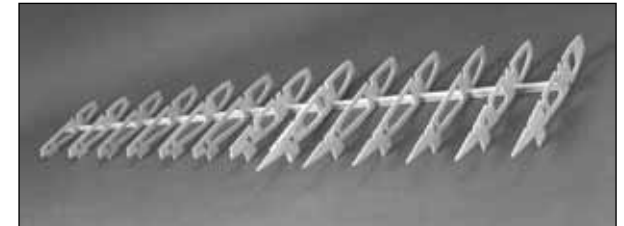

❑ 5. Position the die-cut 3/32" balsa ribs **W-4** through **W-14** on the spar. These should be vertical and aligned over their appropriate locations as indicated on the plans. The **jig tabs** located near the aft end of the ribs should all **contact the work surface**.

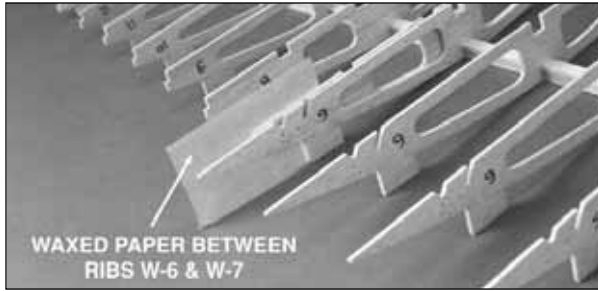

❑ ❑ 6. **NOTE: Complete this step only if you're adding operational flaps.** Slide two layers of waxed paper between ribs W-6 and W-7 from the TE to just forward of the Aft Inner Spar notch. The waxed paper will help prevent the ribs from sticking together when you cut the Flaps free later on.

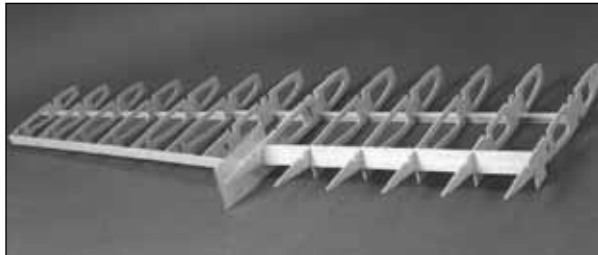

❑ ❑ 7. Fit the die-cut 1/8" balsa **Aft Inner Spar** and **Aft Outer Spar** into the aft notches of ribs W-4 through W-6 and W-7 through W-14 respectively. The upward facing edge of the Aft Inner Spar protrudes above the ribs. Make a mental note of the protruding angle, then, after removing the Aft Inner Spar from the frame, sand a bevel on this edge so that it will be flush with the ribs. *Although you could sand it in place, you would run the risk of deforming the wing ribs.*

❑ ❑ 8. Sight down the TE of the wing from the root end making sure all ribs are aligned. Use paper to shim under the jig tabs of any ribs that are low.

❑ ❑ 9. Check that the upward-facing edges of the ribs and the top surface of the Aft Spars are even and that all of the jig tabs are touching the work surface or shims. When everything is aligned, wick thin CA into all joints. Wick thin CA into **all** seams around the mating surfaces of W-6 and W-7.



❑ ❑ 10. Place part **A** and **B** of the 1/8" die-cut ply **Outer Dihedral Braces** over the pattern on the plan and mark the indicated reference line on both **long edges** of each piece.

**NOTE: Both parts are slightly narrower at one end. Use 6-Minute Epoxy to glue the parts together as shown in the photo. Be sure to make one left and one right set.**

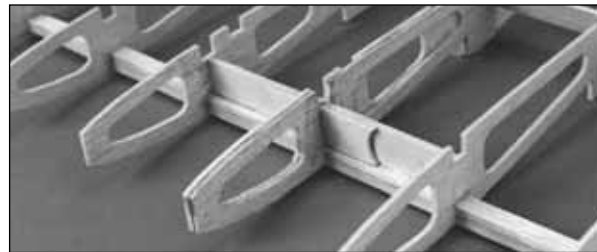

❑ ❑ 11. Use a razor saw to cut a 1/4" wide slot from the upper forward Spar notch down to the lower Spar through ribs W-6 and W-7. Insert the Outer Dihedral Brace into the slot you just cut with the narrow end toward the wing tip and the short portion of the assembly facing the leading edge. The angled edge should be facing upward between ribs W-7 and W-8. **Don't glue it in place yet**, but leave it in position.

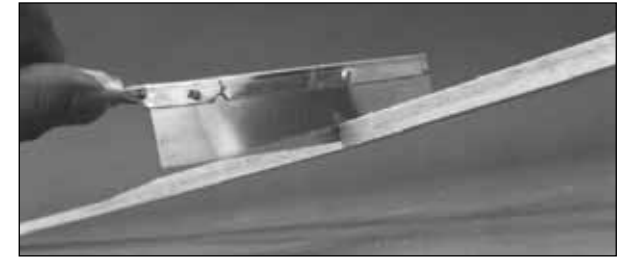

❑ ❑ 12. Hold the upper Outer Spar in position on the ribs, with the inboard end flush with W-4. Mark the Spar at the seam between ribs W-6 and W-7. Score the inside of the spar two thirds of the way through with a razor saw. *The inside is the side with the tapered 1/8" Outer Spar Doubler.*

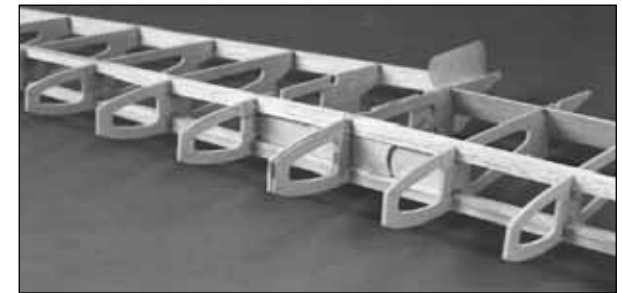

❑ ❑ 13. Press the upper Outer Spar into the wing notches and check for a flush fit at each rib. When satisfied, remove the Outer Spar, then use 30-Minute Epoxy to **glue the Outer Dihedral Brace** in position. Apply a bead of epoxy to the upper edge of the Outer Dihedral Brace, and, before the epoxy cures, install the Outer Spar Assembly and glue it to all the ribs with thin CA.

**NOTE: Work some epoxy into the the saw-cut before laying the Spar in place.**

❑ ❑ 14. Cut four 3-1/8" long **Servo Hatch Rails** from 1/4" x 3/8" x 30" balsa. Glue two of these pieces into the notches in ribs W-4 and W-5 and two between ribs W-7 and W-8. These will support the flap and aileron servo hatches. Install

the rails even if you don't plan to add flaps, as they add a little extra strength and fill in the notches.

☐☐ 15. Glue the 1/8" die-cut **Gusset G-3** to the Aft Outer Spar and W-7, as shown on the plans.

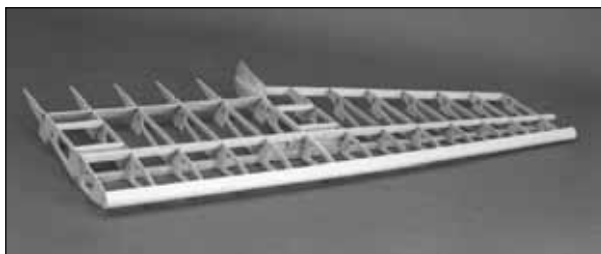

☐☐ 16. Hold the 36" shaped balsa **LE** up to the wing and mark it at W-7. Cut three quarters of the way through the LE (from the flat side) with a razor saw to allow it to flex at W-7. **Center the LE vertically** on the ribs, then **tack glue** it in position at W-4, W-7 and W-14. Sight down the LE from both ends to check that all of the ribs are centered and that the frame isn't curved or twisted. Once again, be sure that **all the jig tabs are firmly on the building board**, then permanently glue the LE to all of the ribs.

 **FLAP SPAR**

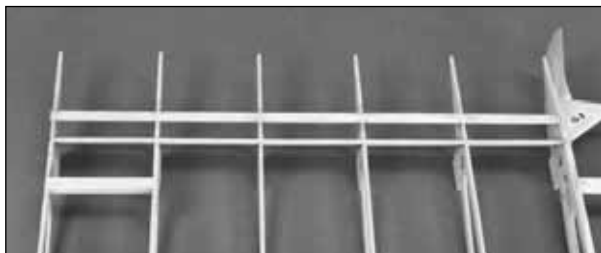

☐☐ 17. Cut the tapered 30" balsa **Flap Spar** to fit from W-4 to W-7 then glue it into the "V" notches just behind the aft Inner Spar.



☐☐ 18. Center a 1/2" x 15" tapered balsa **TE** on the aft edge of W-4 and the last W-6, then glue it in position to only W-4 and W-6. Lay a straight-edge across the aft end of the ribs to check that all ribs are aligned and level and that the TE is straight. When everything looks good, glue all the remaining ribs to the TE, centering each rib as you proceed.

☐☐ 19. Glue the die-cut 1/8" balsa gussets **G1** and **G2** in position, as shown on the plans.

☐☐ 20. Trim the excess material from the Spars, LE, TE, etc., and sand all ends flush. **Reinforce all joints** that still need extra glue by adding medium CA.



☐☐ 21. Refer to the plan for the location of the **single and double** 1/16" x 2-3/4" x 1-1/2" balsa **Shear Webs**. Glue the Shear Webs in position with thick CA (Not between W-4 and W-5).

☐☐ 22. Locate the 1/2" x 1/2" x 6" balsa stick. Cut six 1" lengths to use as **Aileron Hinge Blocks**. Fit and glue 3 blocks where shown on the plans. Save the other 3 for use on the second wing panel.

*Well, that about wraps up the framing for half of the wing. Take a short break to admire your handiwork, have a cup of coffee, clean the CA off your fingers, and kiss your spouse good night. When you're fully revived, clean the sawdust off your bench, swap the plan sheets, and **get busy building the other half**. You can rest later.*

## Prepare the polyhedral braces

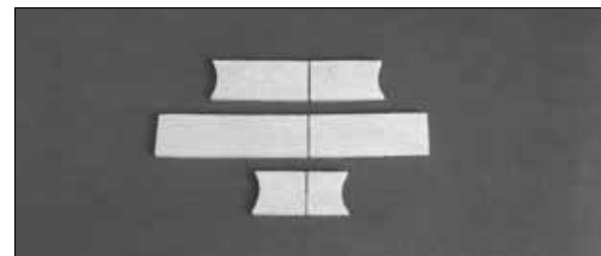

☐☐ 1. Position the three 1/8" ply parts of the **Polyhedral Braces** over the sketch on the plans. Look carefully at each piece and you will notice that they form a slight "V" shape, with one end longer than the other. After you align each piece over the drawing, mark an index line on each part as shown, then extend it around to both edges.



☐☐ 2. **Without gluing**, stack the three pieces together and compare the assembly with the photo and the plans. Repeat this process with the second set of braces, *but this time flip the pieces end-for-end* when you stack them.

You should now have a **right** hand and a **left** hand set of Polyhedral Braces, as shown in the photo. *Tracing around the edges of the two shorter parts will help alignment when you glue them together.*

- □ 3. When satisfied that the braces are accurate, use 6-Minute Epoxy to glue the parts together with the alignment marks perfectly aligned.

### Join the wing panels



- □ 1. Carefully remove a 3/8"-wide strip of balsa from **between the spars** on both the W-3 ribs of the Center Section and the W-4 ribs of the outer panels. This will allow the Polyhedral Braces to be inserted and glued between the spars.

- □ 2. Test fit (but don't glue) the Polyhedral braces into the center and outboard wing panels. **The longer end of the joiner is the end that plugs into the outboard panels.** Sand the ends, if necessary, for a good fit. The wing panels should mate evenly along the joint without any unnecessary twisting or bending to line things up. If you have to force the panels to fit, locate the problem and fix it before proceeding. Any twists will become a permanent part of the structure after the panels are joined and will be difficult to correct.

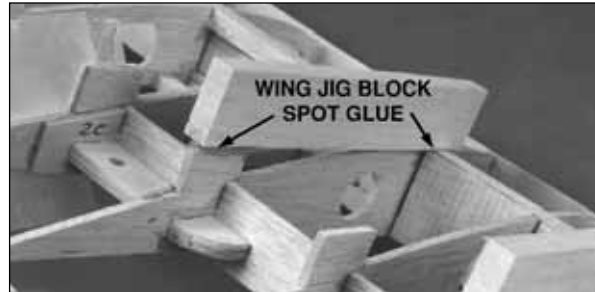

- □ 3. Use only a spot of CA to glue the two 1/4" x 1-1/16" x 5-7/8" balsa **Wing Jig Blocks** to the **W-2 jig tabs** and the **top** of the spar.

*Now for the hard part — cleaning a space on your work bench large enough to spread out and join the wing.*

**IMPORTANT:** Check your work surface with a metal straightedge to make sure that it's perfectly flat before proceeding. Make a "dry run" of the following step before actually performing it with glue.



- □ 4. Place the Center panel on the Jig Blocks in the middle of your work bench. Add some

weight to hold it in place (a few magazines or small sandbags are handy for this). Prepare 1/2 ounce of **30-Minute Epoxy**. Liberally apply epoxy to the **W-3 Ribs**, the **Polyhedral Braces**, and the **spar ends**. *(If you will be installing Flaps, don't put epoxy on the "Flap" portion of the ribs. Insert waxed paper between W-3 and W-4 at the flaps.)* Plug the Polyhedral Braces **into the Outboard Wing Panels**. Plug the Outboard Wing Panels **into the Center Section** and align the Ribs for a flush fit. The protruding Center Section LE and Aft Center Spar tabs will help with alignment. Once all the panels are in position, clamp the ribs together and center the Polyhedral Braces between the Spars as shown on the top view of the plans. **Put weights on the two W-14 ribs** to hold the jig tabs and spars on the work surface. **Before the epoxy kicks off, double check your work.**

**IMPORTANT:** Make certain that **both the upper and lower Spars touch their mates on the adjoining panel**. If, after all your efforts, you end up with a small gap, pack epoxy into the cavity.



- □ 5. Use a razor saw to cut a 1/6" wide x 3/8" deep slot on **both** sides of the bottom spars at W-3. *Remember, the wing is upside down on the bench so the bottom spars are presently on the "top."*



❑ ❑ 6. Test fit the 1/16" die-cut ply bottom **Spar Joiner** in the slots. Just like the Polyhedral Braces, the Spar Joiners have one end that is longer than the other. The longer end points towards the wing tip. Equally sand the ends if needed for a good fit between the ribs. Use 6-minute or 30-Minute Epoxy to glue the Spar Joiners in position. *Clothes pins make handy clamps while the epoxy cures.*

❑ ❑ 7. Turn the wing over and repeat the process of installing the Spar Joiners on the top wing spars.

### ***Sheet the bottom of the wing***

Our suggested wing sheeting process allows you to sheet each of the wing panels with one skin per side — plus a little extra for the flaps. This technique is better than sheeting the wing with individual sheets, and allows you to *pre-sand* all of the seams that will be over open structure.

All balsa sheeting will usually bend when it's cut from the log since internal stresses are relieved. For the best results, trim the edges of the wing sheeting with a long metal straightedge and a **sharp** knife before joining them. You may also try turning the sheets different ways to see if the edges will line up evenly. If the bend is only slight, use 150-grit sandpaper on a long sanding

block to smooth out the curvature. **For more information on making wing skins refer back to page 10 for the *Hot Tip*.**

**NOTE: Do the following steps for both the right and left wing panels.**

❑ 1. Sort through the remaining 1/16" x 3" x 36" balsa sheets and pick out the 6 best sheets to be used for the top surfaces of the outboard wing panels. Pick the best three sheets from the 1/16" x 3" x 21" sheeting to use for the top Center Section skin

❑ 2. Lay waxed paper over a flat, **smooth** work surface.

❑ 3. Make **four outboard wing skins** by edge gluing **three** 1/16" x 3" x 36" balsa wing sheets together to make (four) 9" x 36" skins. Make **one center section** skin using **four** sheets of 1/16" x 3" x 21" balsa. This skin will be cut in half **after sanding** to make **two 12" x 10-1/2"** skins. Refer to page 10 for tips on making skins.

**NOTE: When sheeting, be sure that the wing is resting squarely on the center section Jig Blocks, weighted down on a flat surface, and that the W-14 jig tabs are in solid contact with the building surface.**

❑ 4. Hold a 1/16" x 12" x 10-1/2" center section skin on the bottom surface of the wing with one edge butted up to the LE. Mark the perimeter of the skin. The **side edges of the skin** should be **centered on the joint** between ribs W-3 and W-4. Cut the skin close to the correct size then **sand** it for an exact fit.

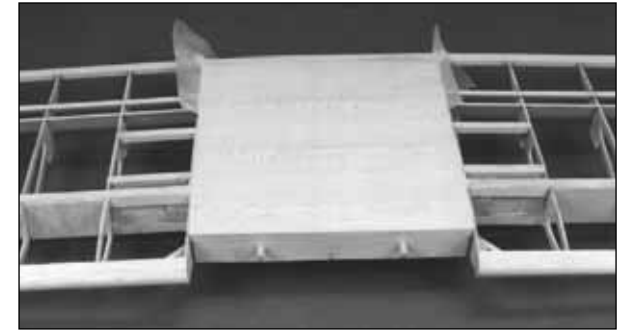

❑ 5. Glue the center skin in position using medium or thick CA. Hold the skin in contact with the frame until the glue has cured.



❑ ❑ 6. Fit one of the 9" x 36" skins in place on an outboard wing panel, with one long edge butted tightly against the inner LE. The inboard edge should overlap the center section. Tape the skin in place. With a flexible ruler, mark the edge that mates with the center panel. Flip the wing over and mark the tip and TE from the back side. *Allow an extra 1/4" around these two edges.* Remove the skin and cut it to the marked size. If necessary, use 220 grit sandpaper to *fine tune* the inboard edge for an **exact** fit. *The photo at step #9 shows approximately what your sheet should look like when it's trimmed.*



The best balsa filler is **no** balsa filler! Take your time fitting all sheeting and skins in place. With a little bit of careful sanding you will be rewarded with perfectly matched joints and a lighter, stronger airframe.

- □ 7. **Working quickly**, apply a bead of **thick CA** to the structure that the skin will touch. Don't glue hatch rails yet. Apply glue to the Spar last. Position the skin over the frame, then press it into place. **Important:** Before the CA kicks off, weight down the center panel and the TE of the wing at W-14 to set the **washout angle**. Repeat steps 6 and 7 for the other outer wing panel.



- □ 8. After the CA has cured, turn the wing over and apply a bead of thick CA to the inside of the LE / Skin junction and any other areas that need a little extra glue.

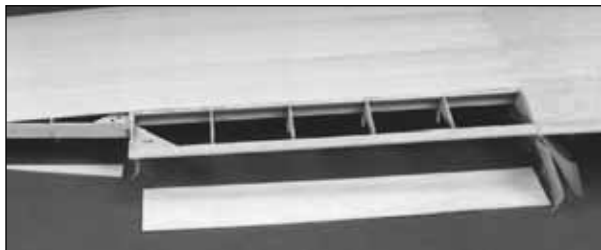

- □ 9. Cut two 14-1/2" pieces from a 1/16" x 3" x 36" balsa sheet. Save the off-cut piece for use

in a few minutes. Cut the 14-1/2" sheets to the fit the uncovered area of the flaps. Use a leftover piece of 1/16" balsa sheeting to make two triangular pieces to fill in remaining un-sheeted area.

- □ 10. Turn the wing over and place it on foam rubber or a soft surface to avoid premature *hangar rash*.

**NOTE: if you are not installing flaps, don't mark or cut the two inboard openings.**



- □ 11. Use a sharpened piece of wire or long T-pin to bore small holes through the skin from the **inside** to mark the location of the flap and aileron servo hatches.



- □ 12. Rough cut the hatch openings on the inside of your guide holes, then use a 1/16" ply **Hatch Cover** to mark and cut the full size opening. *Remember, it's faster to enlarge a hole that's too small than to shrink one that's oversize.* After enlarging holes, use thin CA to glue the skin to the hatch rails.

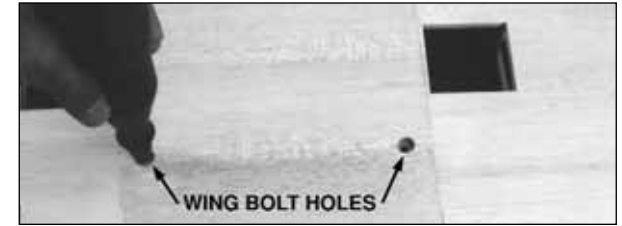

- □ 13. Use a sharpened piece of wire to bore through the exposed side of the Wing Bolt plate to mark the holes in the **bottom** wing skin for the wing bolts. Mark these holes **now**, as it will be difficult to find the location after the top wing skin is applied. To avoid splitting the balsa, bore the holes in the skin with a grinding stone and moto-tool rather than going through with a drill.



- □ 14. You can simplify the job of "fishing" the servo wires through the enclosed wing with a little preparation. Tape one end of a 30" length of string to the inside of the wing sheeting just past the aileron servo hatch opening. Thread the string through the lightening holes in the ribs into the center section. Bore a 1/2" hole for the servo leads to exit through the bottom of the wing. Secure the string next to the hole with another piece of tape. Repeat this procedure for the other wing panel. When the time comes to thread the servo wires, just tie them to the string from the hatch end and pull them through to the center compartment exit hole.

*If you plan to install navigation lights on the wing tips, use the string technique described in the*

previous step, or glue two large-diameter pushrod tubes (not supplied) inside the wing, ahead of the spars, to serve as a conduit for the wires.

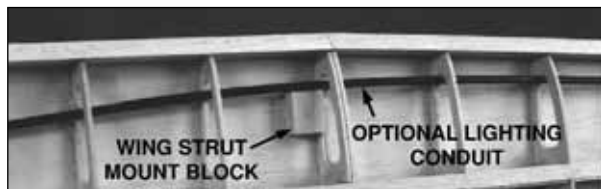

□ □ 15. Glue the 1/2" x 1/2" x 1" basswood **Wing Strut Mount Block** to the inboard side of the W-6 rib and to the sheeting at the location shown on the plans. We recommend 6-Minute Epoxy for this job. To help locate the blocks later, drill a 1/16" hole through the center of the blocks, out through the bottom sheeting.



□ □ 16. True all edges with a sanding block. Mark the location of the Aileron Hinge Blocks on the outside edge of the aft Outer Spar.

□ □ 17. Carefully cut off all of the jig tabs on the top surface of the wing. Lightly sand the tops of the ribs and spars. Clean up any glue blobs that will interfere with the top sheeting, then double check your work.

*If you aren't installing operational flaps (the neat looking, highly effective, simulated Fowler Flaps) skip the next section and proceed to "Sheet The Top Of The Wing". Are you sure you won't reconsider?*

## Prepare the wing panels for the flaps

Do the following steps if you are building operational flaps.

*Even though building operational flaps requires a little bit of patience and elbow grease, you will be rewarded by more scale appearance and slower landings than the less ambitious modeler. If that isn't enough, they look great during slow fly-bys and shorten the takeoff roll.*

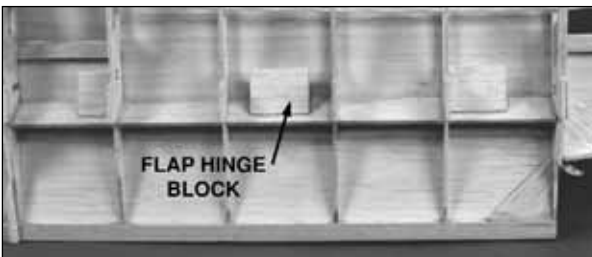

□ □ 1. Cut the shaped 5/8" x 9" balsa **Flap Hinge Block** into four pieces 1-1/2" long, and two pieces 1" long. Glue the blocks to the aft Inner Spar, sheeting, and ribs as shown on the plans.

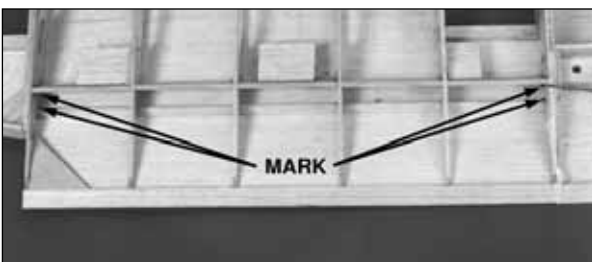

□ □ 2. Mark the location for the **Flap LE** by inserting a sharpened wire through the sheeting at the locations shown in the photo.

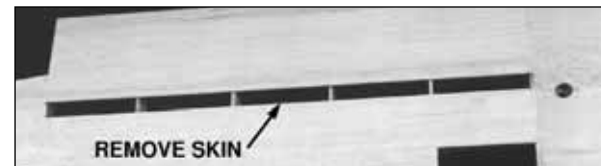

□ □ 3. Turn the wing over, then **carefully** cut away the balsa sheeting from between the marks. Don't cut through the ribs until the top of the wing has been sheeted and you are instructed to do so.

*That's all you need to do for now regarding the flaps. Let's move on and put the skins on the top of the wing.*

## Sheet the top of the wing

**NOTE:** This kit includes a special set of wing jigs to hold the wing at the proper washout angle (2 degrees washout at each tip) while you apply the top skins. Twisted wings are a major cause of bad flight characteristics. Polyhedral angles can vary slightly, so if your tip jigs require adjustment, just be sure that both tip jigs are modified the same, and are therefore identical. Be careful not to change the washout angle (the negative angle of attack of the tip ribs) if you adjust the jigs.

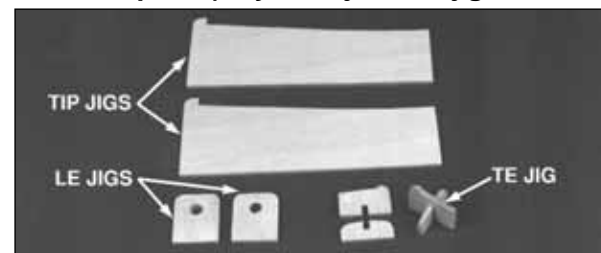

□ □ 1. Locate all of the 1/8" die-cut ply wing jigs as shown in the photo. Assemble the two parts of both **TE Jigs** as shown.

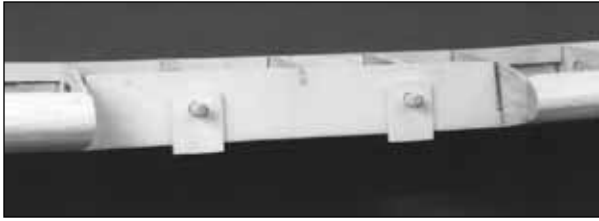

□ □ 2. Slide the die-cut 1/8" ply **LE Jigs** over the dowels, with the flat edge towards the sheeted (bottom) side of the wing.

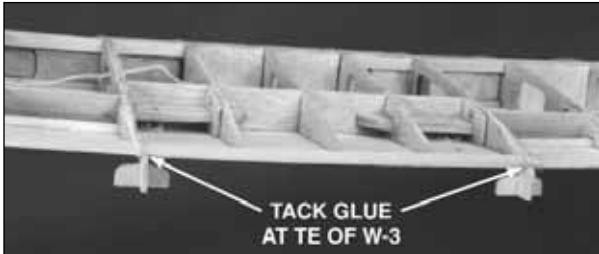

□ □ 3. Tack glue the die-cut 1/8" ply **TE Jigs** to the sheeting at the TE of W-3.

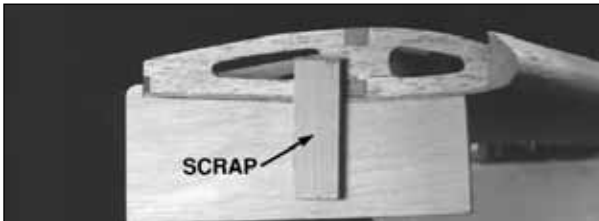

□ □ 4. Place a die-cut 1/8" plywood **Tip Jig** under each W-14 rib with the raised tip of the jig butting up to the TE spar. Tack glue it in place.



Glue a piece of scrap ply to the side of the jig and also to the W-14 ribs (as shown here) to prevent the jig from moving or having to glue it to the sheeting.

**NOTE: Use the same procedure to sheet the top of the wing as you used for the bottom.**

□ □ 5. Cut the top **Center Panel Skin** from the skin you made earlier. Remember that it should line up with the dividing line between ribs W-3 and W-4. When satisfied with the fit, glue it in place with thick CA.

□ □ 6. Check the fit of an outboard skin to the wing structure. Make adjustments if required to fit flush with the LE and Center Panel. Sand a slight bevel to the edge of the skin that will contact the LE to allow for a better gluing surface. Use thick CA to glue the skin in position. Hold the skin firmly in place while the CA cures. *Magazines make good weights.* Wick thin CA along the LE seam, wiping off any excess CA before it hardens.

□ □ 7. Repeat step 6 for the other outer panel.

□ □ 8. Measure, cut and glue a 1/16" x 3" x 36" balsa sheet to fit over the Flaps and the openings at the aft edge of the wing skins, as you did for the bottom of the wing.

*At this point you should have the main wing structure fully sheeted. You may now remove all Jig parts from the wing and sand off any glue marks.*

## WING COMPLETION

□ □ 1. Trim the sheeting where it protrudes past the edge of the structure.

□ □ 2. Sand the wing **Leading Edge** until it blends well with the sheeting to form a smooth airfoil.

□ □ 3. Square off the wing tips with a T-bar.



□ □ 4. Use a pointed piece of wire to mark the holes for the wing bolts from the bottom, **through** the top wing skin. Use a hobby knife to carefully cut a 1/4" hole in the sheeting around the points you marked. Insert one of the 1/4" nylon wing bolts through the wing from the top, and trace around the head with a pen. Enlarge the holes to the circles you just drew to allow the wing mounting bolts to seat against the wing mounting plates. Use a round file or Moto-Tool and grinding drum to avoid tearing the sheeting.

**IMPORTANT: The Ailerons must be fitted to the wing and the hinge bevels sanded before installing the wing tips or cutting the flaps loose.**

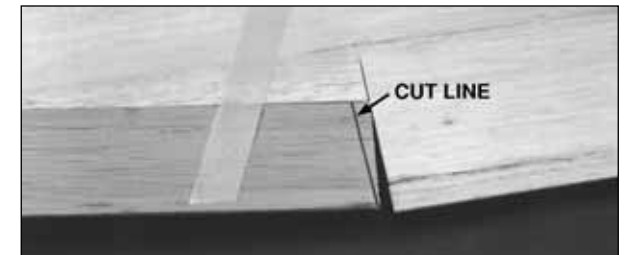

□ □ 5. Tape a tapered 2-3/32" x 21" balsa **Aileron** to the **Outer Aft Spar** with one end against W-7. *Don't be alarmed if the Aileron TE is higher than the TE at W-7; this will be taken care of when the aileron LE is tapered.* Draw a line on the Aileron, parallel to the edge of W-7. Remove the Aileron, then cut and sand it to this line. Check the fit and make any minor corrections as needed.

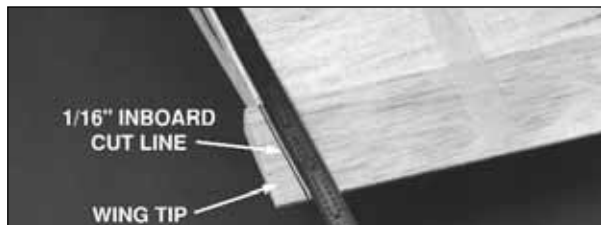

❑❑ 6. Tape the Aileron back into position. Mark the tip end with a straightedge placed along W-14. **Draw a line 1/16" inboard of the first line.** Cut off the Aileron tip on the second (inboard) line. By so doing the Aileron will have 1/32" clearance on both ends when it's installed.

❑❑ 7. Draw a centerline on the LE of the Aileron. Sand a "V" shaped bevel along this edge. Refer to the wing cross section on the plans for the required angle.

❑❑ 8. Tape the Aileron **securely** in position with its **TE aligned with the TE at W-7.**



❑❑ 9. Tape a shaped balsa Wing Tip in position. It should be centered on W-14 and the aft end should be centered on the TE of the Aileron. Trace the airfoil onto the inside edge of the wing tip.

**NOTE: Horner Tips are an option on full-scale Cessnas. If you prefer, you may simply carve a standard tip without the undercamber. Draw an arc the width of the Aileron's TE (as shown on the plans) if you want to carve Horner Tips. Remove the tip.**

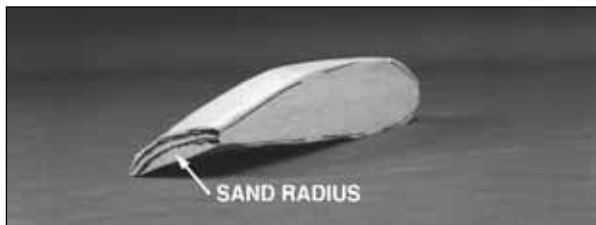

❑❑ 10. Use a long carving blade to carve away most of the excess wood and rough in the shape of the tip. To carve a Horner Tip, cut away a wedge of balsa as shown in the photo, then use a round sanding tool (e.g., 80-grit sandpaper wrapped around a short piece of broom handle) to curve the underside.

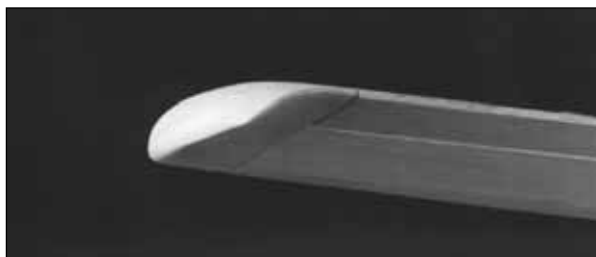
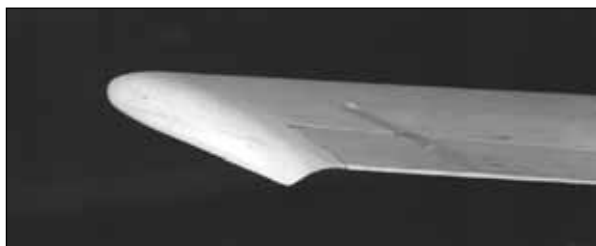

❑❑ 11. When the Wing Tip has been shaped close to finished size, glue it to W-14 with medium CA. *Don't glue it to the Aileron.* Finish sanding the Wing Tip with 220 grit sandpaper, blending it with the wing sheeting and LE. Fine tune the curved undercamber portion of the Wing Tip with a round sanding tool and 220 grit. The thickness of the Tip's TE should match the thickness of the Aileron TE.



❑❑ 12. Refer to the plans for the aileron horn location. Position a die-cut 1/8" x 5/8" x 5/8" ply **Horn Reinforcement** on the bottom of the aileron at this location and score around its perimeter with a hobby knife. Remove balsa from within the score marks to recess the horn reinforcement. Use thick CA to glue the horn reinforcement in place.

❑❑ 13. Repeat steps 5-12 for the other wing panel.

*If you are building your wing without operational flaps, there's nothing left to do except fit the wing to the cabin during final assembly. Invite your buddies back to the shop for a progress update. Also, your floor needs sweeping.*

**NOTE: If you are NOT building operational Flaps, skip the following section and proceed to BUILD THE FUSELAGE.**

## BUILD THE FLAPS

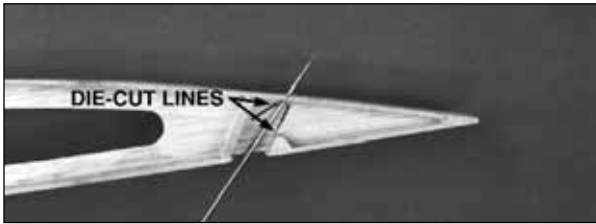

❑❑ 1. When you look inside the slot that you cut in the sheeting along the Flap LE, you will see two partially die-cut lines on each rib. Insert a pointed piece of wire between the lines, through the top wing sheeting at each end of the flap. **We are using a wing section mockup for the purpose of explanation.**



❑❑ 2. Turn the wing over, then use a straightedge and hobby knife to cut through the top sheeting, across the two reference marks, along the length of the flap.



❑❑ 3. Use a **new #11 blade** to carefully cut through each rib at the **aft die-cut** line. In the event that some CA has glued the wax paper

together, cut the inboard and outboard ends of the Flaps free with a hobby knife or razor saw.



❑❑ 4. Sand the LE of the Flap Rib flush (and at the same angle) with the Flap Spar. Use a long T-bar or sanding block to maintain a straight LE.

❑❑ 5. Refer to the plans for the location of the 1/16" die-cut birch ply **Flap Horn**. **NOTE:** There is a different Flap Horn location for each flap, so double check your work over the plans. Glue the Flap Horn in position with thick CA.

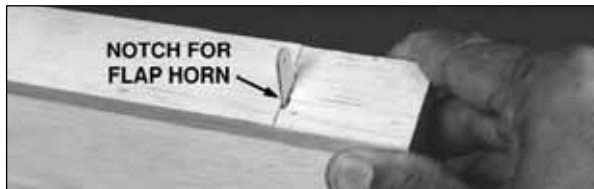
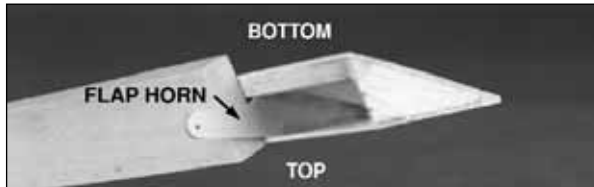

❑❑ 6. Cut a 1/2" x 1-1/4" x 14-1/2" balsa **Flap LE** to fit on both sides of the Flap Horn. Cut a 1/16" deep notch in **one** of the Flap LE sections to allow passage of the Flap Horn. Glue the Flap LE in position **exactly** as shown in the photo, with the top of the Flap flush with the top of the Flap LE.

❑❑ 7. Shape the Flap LE to match the cross section on the plans. A razor plane, whittling knife, and coarse sandpaper help the job go quickly. The die-cut 1/8" ply **Flap Hinge Drill Guide** may be used to test the curvature of the LE (*See step # 2 of "Fit The Flaps"*).

❑❑ 8. Repeat steps 1 - 7 for the other Flap.



❑❑ 9. Trim off the excess balsa from the Inner Aft Spar, then use a 3/4" dowel wrapped with 220-grit sandpaper to sand a radius on the protruding portions of the ribs. Cut a 1/4" x 1/2" slot in the Inner Aft Spar to allow the Flap Horn and Clevis to clear.

❑❑ 10. Reinforce the underside of the wing sheeting (where it overhangs the aft inner spar at the Flaps) by gluing leftover 1/16" x 1/4" balsa strips between the ribs on the underside of the top sheeting. Sand a bevel along this edge to allow the flap to clear when it's in the *up* position.

### *Fit the flaps*

❑❑ 1. Use a T-bar to true-up the aft edge of the wing sheeting in the flap section.

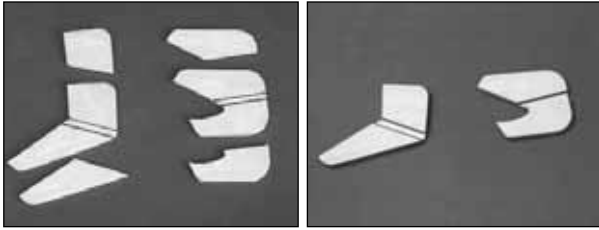

□ □ 2. Assemble the two **Flap Drill Guides (A&B)** by gluing the six die-cut 1/8" ply pieces as shown.

□ □ 3. Test fit the flaps. Check that all edges are flush.



□ □ 4. When a good fit is obtained, install large Robart **Pivot Point Hinges**. **NOTE:** The hinges are **not glued** in until **after** the finish has been applied. Determine the hinge locations from the plans (if you forgot to mark them in the aft inner spar), then drill 3/16" holes at the hinge locations using the drill guides to obtain the correct angle for the hinge



□ □ 5. Plug the flaps with the hinges into the wing. Check the fit and run the flaps through their complete range of motion. Make any required adjustments until the flaps swing freely. Remember, the flaps must **close flush** against the wing TE.

## BUILD THE FUSELAGE

### *Build the fuselage bottom framework*

**NOTE:** The 1/8" die-cut plywood formers are stamped only with the necessary portion of their name. For example, F-2B is stamped 2B.

**IMPORTANT:** Before starting assembly, drill a 3/16" pushrod hole through each of the **punch-marks on formers F-2 - F-8**. All formers must be installed with the stamped identification number facing forward. This is necessary to align the pushrod holes.

□ 1. Pin the **bottom view** of the Fuselage plan to a flat building surface, then cover it with waxed paper. Cut the plans apart if necessary.

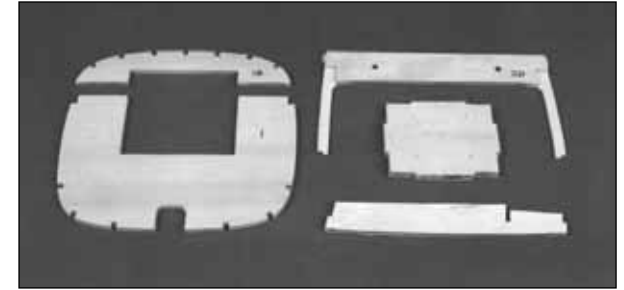

□ 2. Use 30-Minute Epoxy to glue the following **1/8" die-cut ply parts** together to make sub-assemblies:

- A) Two **F-1** formers. Make sure the notches are aligned.
- B) Two **F-1B** formers. **Don't glue them to F-1.**
- C) Two **Fuse Keel** parts. Apply weight to hold them flat.
- D) Two **FW-A** and one **FW-B** Firewall. Make sure that FW-B is on the "bottom" of the stack and that all the tabs are aligned.
- E) **F2-B** and **F2-D**. F2-D must be glued to the **forward face** of F2-B. Make sure that the dowel holes are aligned.

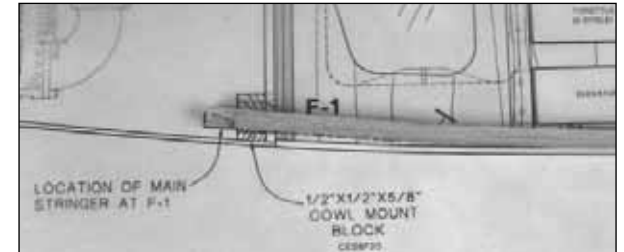

□ 3. Pin the 3/16" x 3/8" x 48" grooved **Main Stringers** to the plans. Be sure that the Main Stringers are aligned with the outside edge of the formers and **NOT** the outside sheeting line on the plans. When pinning the Main Stringers at F-1, **align them with the dashed line that extends past F-1**. The **1/8" groove faces to the outside** of the fuse. Leave excess material extending beyond F-1 and at the tail for trimming to size later.

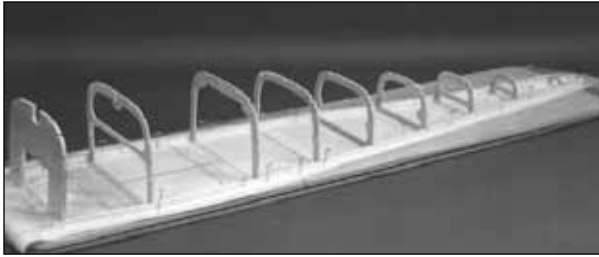

❑ 4. Position (without glue) **F-1** through **F-9** over the plans and Main Stringer. Are your 3/16" pushrod holes drilled?

**IMPORTANT NOTE:** Cut the "Former Angle" Template from the plans and glue it to stiff cardstock or scrap wood. Trim and sand it to size. Hold it on the AFT side of all formers to position them at the correct angle while gluing. Any small warps or twists will be taken out when the 3/16" stringers are glued in later.



❑ 5. Using the Former Angle template, start gluing the **formers** to the Main Stringers starting with **F-3**, **working towards the rear**. **Don't glue F-1 or F-2 yet.**



❑ 6. Insert (**without gluing**) two 3/16" x 3/16" x 48" **stringers** into the lowest notches on both

sides, that run from F-1 to F-9 as shown in the photograph. Starting at F-9, **check the former angle once again with the Former Angle template**. Make sure that you straighten out any twists, then glue the stringers to F-9 with thin CA. Continue forward, **checking and aligning** each former before reaching for the CA. **F-3 is the last former you need to glue to the stringers at this time.**

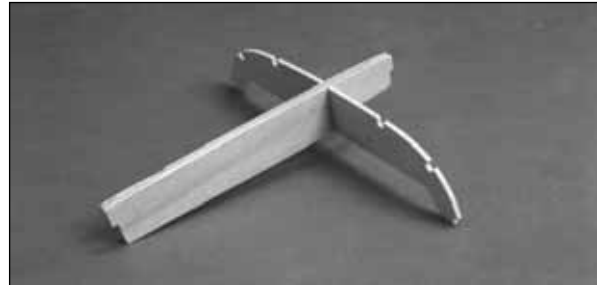

❑ 7. Insert and glue the 1/8" die-cut former **LF** into the slot in the fuse Keel. Make sure that it is square and flush with the top and bottom of the Keel.

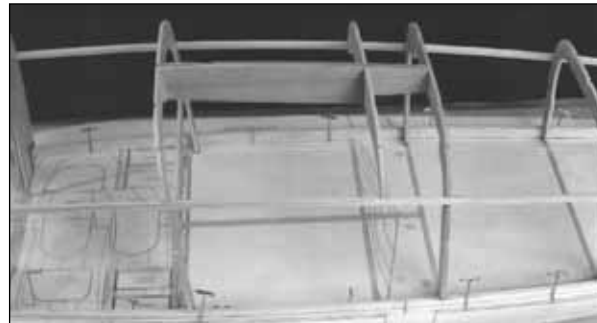

❑ 8. Insert the Keel assembly into the upper center notches of F-2 and F-3. The notches on the tips of LF should be resting on the 3/16" stringers. Adjust F-2 so that the bottom ends are over the dashed reference lines on the plan and the forward edge of the Keel is flush with the aft side of F-2. Glue F-2, the Keel and LF at all points of contact.

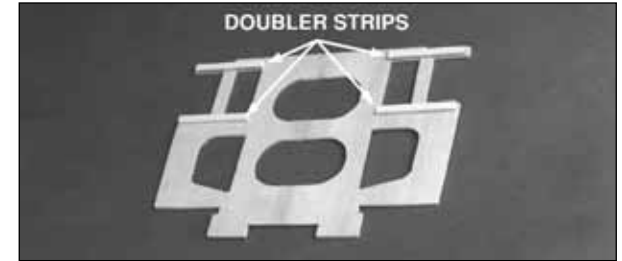

❑ 9. Glue the two halves of the die-cut 1/8" ply **Servo Tray** together. Cut four 1/8" x 1/4" x 2-1/4" doubler strips from scrap ply left over from die-cut sheets. Glue these doublers on both ends of the servo holes for reinforcement.

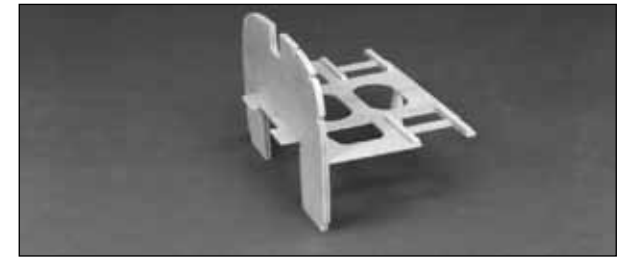

❑ 10. Carefully lift F-1 out of the frame. *You didn't glue it in, did you?* Insert the forward end of the Servo Tray into the Firewall opening in F-1. The servo reinforcement strips should face **away** from the building board.

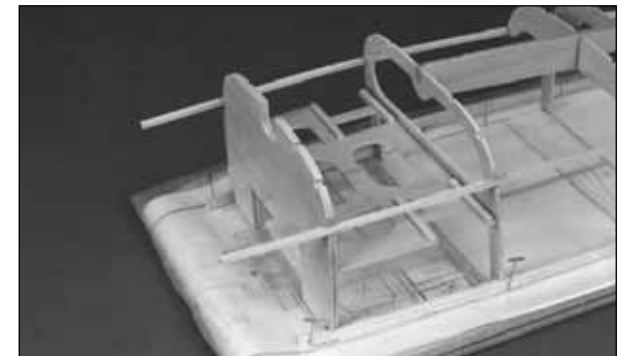

❑ 11. Fit F-1 and the Servo Tray back into the fuse frame. Work the aft end of the Servo Tray into the notch in F-2. Align F-1 over the plan.

When everything is locked in place, glue the assembly together. The 3/16" side stringers may now be trimmed flush with the forward edge of F-1.

❑ 12. Lightly sand the outside of the two 36" outer pushrod tubes then insert them through the holes in F-2 through F-8. Trim the tubes so that 1/4" protrudes past F-2 and F-8. Apply a drop of medium CA to the pushrod tubes at each former **except F-2**.



❑ 13. Use 30-Minute Epoxy to glue the 1/4" birch ply **Landing Gear Plate** between former LF and F-3. Be sure that the notches fit well and that the Landing Gear Plate is firmly against the Keel. *While the epoxy cures there are a few other parts we can work on.*

❑ 14. Cut two 3/16" stringers from the 24" lengths provided, to **fit from F-2 to F-4 in the first set of notches above the Main Stringer**. Glue them in place, then sand the ends flush with the formers.



❑ 15. Glue the 1/8" die-cut ply **Nose Gear Doubler** to the aft side of F-1. Be sure to align the stringer notches.



❑ 16. Center the nylon **Nose Gear Bearing** on the tapered 1-1/4" x 1-5/8" basswood **Nose Gear Block**. Mark the mounting holes in the Nose Gear Block, then drill the holes with a 1/8" bit. Drill the four **index marks** on the forward side of F-1 with a 5/32" bit.



❑ 17. Install the Nose Gear Bearing/Block on F-1 with four 4-40 x 1" Pan Head Bolts and four 4-40 Blind Nuts. The wide end of the Nose Gear Block points **away from the building board**. Drill out the Nose Gear Wire Hole with a 13/64" drill bit. Remove the Nose Gear Bearing/Block then use thick CA to mount the basswood block permanently to F-1. Be sure that all of the mounting holes stay in alignment.



❑ 18. After the epoxy on the 1/4" Landing Gear Plate has fully cured (*an hour or more*) **clamp** both of the bent aluminum **Main Landing Gear** struts in position. The struts should touch the Keel and F-3. Use a 9/64" drill bit to drill through the mounting holes in the struts and also through the Landing Gear Plate. Enlarge the holes in **only the plywood** Landing Gear Plate with an 11/64" (or 3/16") drill bit to provide clearance for the 8-32 mounting bolts.

❑ 19. Use an **8-32 Tap to cut threads** in the aluminum Main Landing Gear mounting holes as well as the axle mounting holes. Temporarily install the Landing Gear in the fuse with six **8-32 x 1/2"** socket head cap screws.

❑ 20. **IMPORTANT: Before you do this step, make certain that the Main Stringers are pinned or weighted FLAT onto the building surface.** Cut and install all the remaining 3/16" square stringers for the fuse bottom. Check each former for twists and the correct angle before you use glue. Use the Former Angle Template as you proceed. The inside ends of the center stringer should be sanded for a flush fit, then butt glued to the ends of the Keel.

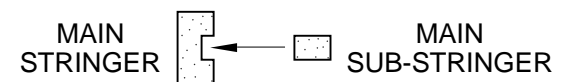

❑ 21. Glue two of the four 1/8" x 3/16" x 24" **Main Sub-Stringers** into the groove in one of

the Main Stringer. Use Thin CA, wiping up any excess before it dries. Repeat for the other side. These Sub-Stringers will provide a ledge for the side sheeting.

❑ 22. Lightly sand all joints and blend the stringers with the formers in preparation for sheeting. The bottom fuse framework is now ready for sheeting.

### Sheet the fuselage bottom frame

❑ 1. Remove the Main Landing Gear struts, then pin the fuse framework back on the flat building surface. Push T-pins in at an angle through the Main Sub-Stringer in a way that won't interfere with the sheeting.



❑ 2. Pin one of the 3/32" x 4" x 48" balsa **Fuse Side Sheets** to the Main Stringer. Curve the sheet into contact with the frame, then use pins, masking tape and clothes pins to hold it against the the stringers.



❑ 3. Mark the **top edge** of the **first full-length 3/16" Stringer** onto the Fuse Side sheet, working from the **inside** of the fuse.



❑ 4. Remove the **Fuse Side** sheet. Carefully cut away the excess material. Check the fit and make adjustments as needed with a hobby knife and sanding block to the top and bottom edges. When the sheet is **flush with the top of the stringer**, carefully trim away another 3/32" from the **bottom** edge. The Fuse Side sheet should now bisect the stringer, allowing for a glue surface for the next sheet. Test fit the Fuse Side sheet on the other side of the fuse, then cut a second Fuse Side using the first one as a pattern.

❑ 5. Wipe a damp paper towel over the outside surface of the Fuse Side to aid with curving the balsa.

❑ 6. Realign a Fuse Side sheet with the framework, then wick some thin CA into the joint between the Main Stringer and the Fuse Side **starting midway between the front and back of the Fuse**. Carefully work outward in both directions along the Main Stringer, holding the Fuse Side in tight contact with the Main Stringer as you proceed.



❑ 7. Clip and pin (or tape) the **top edge** of the Fuse Side to the first stringer. Wick thin CA

into the joint, but wipe off any excess before it cures. Avoid using CA accelerator as it will create lumps along the seam that will cause problems when you try to add the next piece of sheeting. Repeat Steps 4, 5 and 6 for the other side.



❑ 8. Rub a piece of **chalk** along the top outside edge of a Fuse Side sheet.

❑ 9. Cut two 3/32" x 3" x 36" balsa sheets down to 26". Save the cut off pieces for later use.



❑ 10. Wet the outside of one of these sheets, then **flex it with the grain** for a minute or two to soften it up and start a curve. Align the sheet along the centerline of the 3rd stringer and the centerline of F-3, then temporarily hold it in place with clothespins. Mark the lower edge to match the top edge of the Fuse Side by pressing it against the chalk. Remove the sheet, turn it over and cut along the chalk line for a perfect fit!

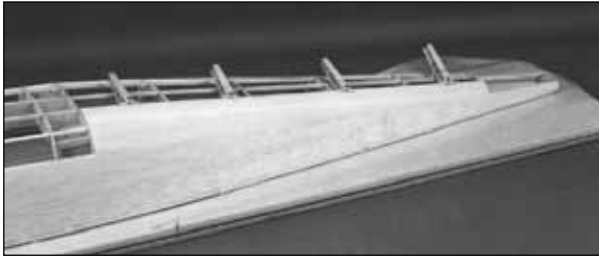

□ □ 11. Apply medium CA to all frame parts that the sheet will contact **except the top stringer**. Roll the sheet into position, starting along the lower edge. Hold it in position by hand and with clothespins until the CA cures. Wick thin CA along the top seam, wiping off the excess before it cures. Repeat Steps 7-11 for the other side of the fuse.

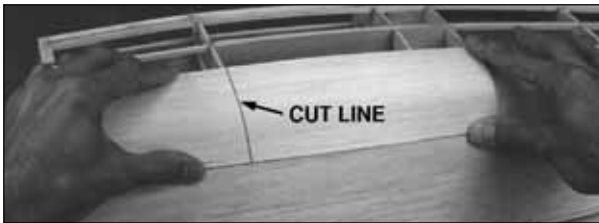

□ □ 12. Cut **two 13-1/4"** lengths from a **3/32" x 3" x 36"** balsa sheet. Hold one of the 13-1/4" sheets in position on the top edge of the Fuse Side from F-3 to F-1. Draw a line on the sheet that bisects F-2, top to bottom. *Remember, F-2 angles forward.* Cut the sheet on the line.

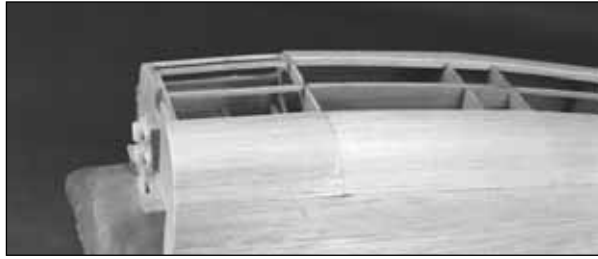

□ □ 13. Use the same sheeting technique as Steps 7-11 to sheet from F-3 forward to F-2. If the sheeting is not wide enough, glue a strip of leftover 3/32" balsa to one edge. Use the second half of the 13-1/4" balsa sheet to sheet from F-2 to F-1. If the sheeting is not wide enough, glue a strip of leftover 3/32" balsa to one edge.

□ □ 14. Repeat Steps 12 and 13 for the other side of the fuse.

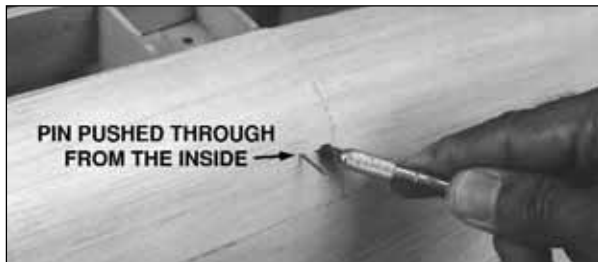

□ □ 15. Mark the location of the Main Landing Gear by pushing a long T-pin through the sheeting between LF and F-3 with the pin flat on the upper surface of the Landing Gear Plate. Use the pin as a reference point to cut a 1/4" x 1-1/2" slot for the Main Landing Gear. The slot must be even with the Landing Gear Plate and F-3. *Don't worry if the slot is slightly oversized as it will be covered with an ABS fairing during final assembly.*

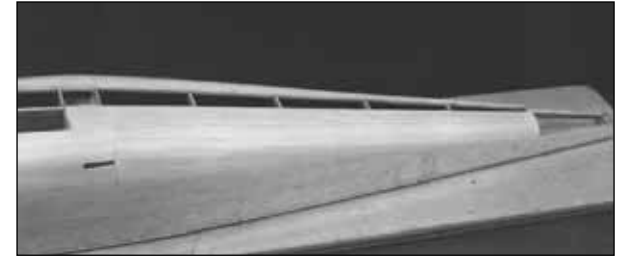

□ □ 16. Clean up the inside edges of the sheeting along the third stringer with a T-bar and 150-grit sandpaper. Clip a 3/32" x 2" x 30" balsa sheet along the centerline of the center stringer, from LF to F-9. Use the chalk technique to mark the outline, then trim the sheet to size. Glue the sheet in position.

□ □ 17. Fit, cut and glue the other 2"-wide bottom sheet in the same manner.

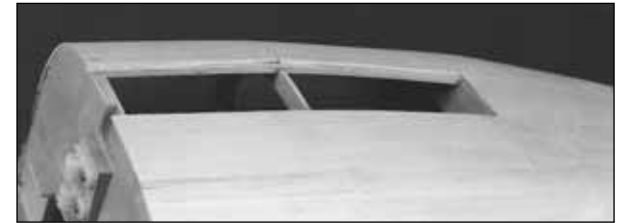

□ □ 18. Cut the 3/32" x 2-3/4" x 24" forward bottom sheet into two 12" lengths. Use the same chalk technique to fit, cut and glue the two forward bottom sheets between LF and F-1.

□ □ 19. When the all of the balsa sheeting is dry, lightly sand the joints with 220-grit sandpaper. Sand the sheeting flush with F-1 and F-9.



Remove the hull (I meant to say fuselage) from the building board, and install the landing gear with six 8-32 x 1/2" socket head cap screws. The landing gear struts provide a built-in stand to help avoid hangar rash on the underside. Looks pretty sleek, huh?

**SPECIAL BUILDER'S NOTE:** As this model has been designed with the scale builder in mind, the servos, receiver, battery and tank are all hidden under the instrument panel so they are less conspicuous and leave the cabin interior open for unlimited detailing. Because of this location you will find it much easier to install these components before the top of the fuse is assembled. We are not saying that they can't be installed (or removed) later, it's just *much easier* to do it now.

### Fuelproof and paint the interior

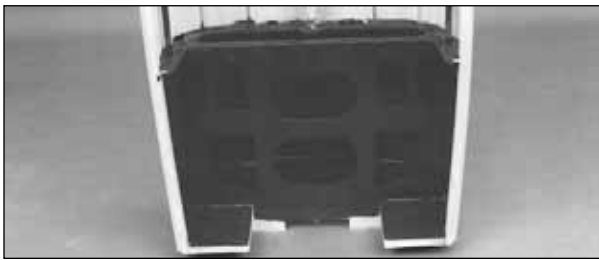

❑ Before assembling the fuse top, fuel proof and paint the interior from F-1 to F-2 including the

servo tray. We used K & B Black Super Poxy paint with satin catalyst to do both jobs at one time.

### Install pushrods and servos

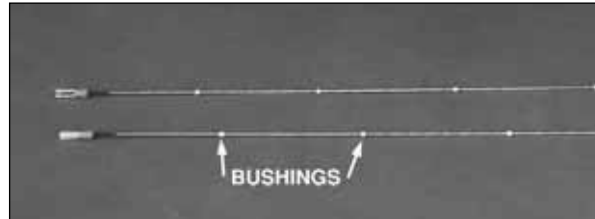

❑ 1. Locate the two .074" x 36" **Pushrod Wires**. Cut six or seven 1/4" long bushings of inner pushrod tube, then slide these along the wire from the unthreaded end. Space them out evenly but make sure that the bushings on the ends are at least 4" from the end of the wire. If the bushings slide too easily, use a small drop of thin CA to hold them in position. Slide a silicone **Retainer** onto the rear of a nylon **Clevis**, then screw the Clevis onto the Pushrod about 14 turns. Make a second Pushrod in the same manner.

❑ 2. Make sure that the CA on the bushings has **thoroughly cured** (you don't want the Pushrods glued to the inside of the tubes) then insert the Pushrod wires over the top of F-1 into the **forward** end of the Pushrod Tubes and slide them all the way through.

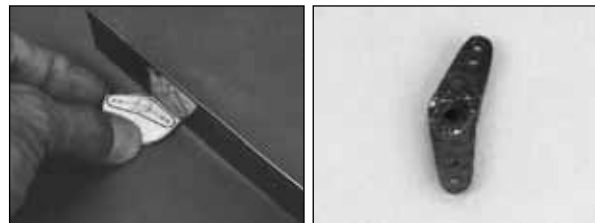

❑ 3. Cut the **Rudder Servo Horn pattern** from

the plans and glue it to a large servo wheel with rubber cement. Cut out the custom horn shape with a razor saw and grinding wheel. Drill the clevis holes with a 1/16" bit.



❑ 4. Install three servos as shown with their **splined shafts toward F-1**. Depending on engine choice (2-stroke or 4-stroke), the throttle servo location can be on either the left or the right side of the servo tray. The receiver **switch** can also be installed in the servo tray at this time, or you could mount it through the fuse sheeting during final assembly.

### Frame fuselage top

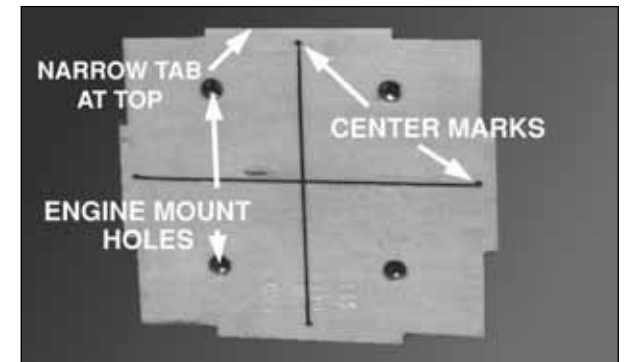

❑ 1. Drill four 15/64" diameter holes through the laminated Firewall for the engine mounting bolts at the marked locations. Insert four 8-32 blind nuts into the holes from the aft side (that's the side with the lightning hole) and seat them with gentle taps from a hammer. Wick a little thin CA around the edge of each nut to secure it in position.

**NOTE:** Test fit the entire following assembly (Steps 2-5) before using any glue.



❑ 2. Mix 1/4 oz. of 30-Minute Epoxy. Use epoxy to glue the two die-cut 1/8" ply **Firewall Side Supports** to F-1 and the Servo Tray.

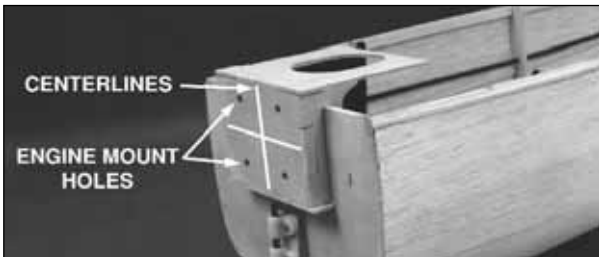

❑ 3. Use epoxy to glue the **Firewall** between the two Side Supports and then glue the die-cut 1/8" ply **Tank Roof** in position.



❑ 4. Use medium CA to glue the die-cut 1/8" ply **Instrument Panel (IP)** to the top of the Main Stringer 3-5/8" behind the forward edge of F-1 and also to the aft edge of the Tank Roof. *Line up the Tank Roof between the punched index marks on IP.*

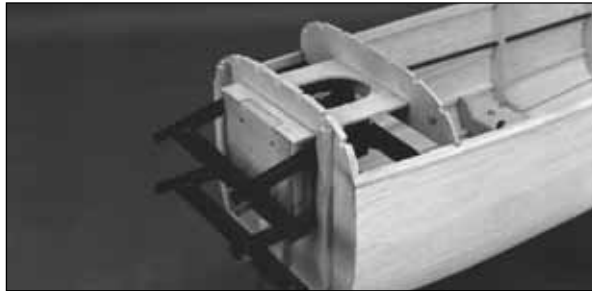

❑ 5. Use epoxy to glue **F-1B** to the top edge of F-1 and the Tank Roof. A couple of scrap sticks spot glued to the forward face of F-1 will help align F-1B.

**NOTE:** Before the epoxy cures, use clamps and masking tape to hold all parts in alignment and in tight contact with each other.



❑ 6. Glue F-5B, F-6B, F-7B and F-8B on top of formers F-5 through F-8. Hold a straightedge across both former halves to align them.

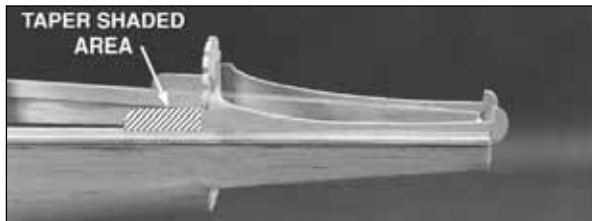

❑ 7. Lightly taper the top forward edge of the two die-cut 1/8" ply **Stab Saddles** to allow for the curvature of the sheeting, then glue them to the top of the Main Stringer between F-8B and F-9.

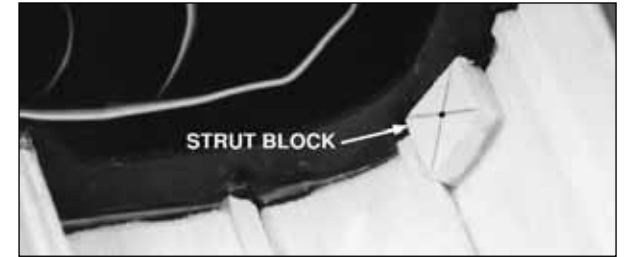

❑ 8. Draw an "X" from corner to corner on two 5/16" x 3/4" x 7/8" basswood **Strut Blocks** to locate the center point. Drill a 1/16" dia. hole through the the Strut Block where the lines cross. Position the Strut Blocks on second stringer (See the strut section on the wing plan) from the bottom at F-2. You will need to sand a slight radius on the Strut Blocks so that they will fit flush against the sheeting. Sand a taper along the forward edge so that they will fit flush against F-2. It is important to keep both Strut Blocks the same size. Glue them in place when satisfied with the fit.

❑ 9. Glue the die-cut 1/8" ply **F-2B/F-2D** and **F-3B** formers to the Main Stringer above F-2 and F-3.



❑ 10. Glue the die-cut 1/8" ply former doublers **F-2C** and **F-3C** to the forward faces of F-2B and F-3B. The notches interlock with the Main Stringer.



❑ 11. Check alignment, then glue the die-cut 1/8" ply **Wing Saddle Braces** into the notches on F-2B and F-3B.



❑ 12. Fit the die-cut 1/8" ply rear **Window Frames** into the notches in F-5B and the Wing Saddle Braces. The upper ends should protrude above the Wing Saddle Brace about 3/32". Glue the Rear Window Frames into position then lightly sand the protruding tips, leaving about 1/16" above the Wing Saddle Brace.

❑ 13. Glue the top and bottom die-cut 3/32" balsa **Cabin Sides** together.

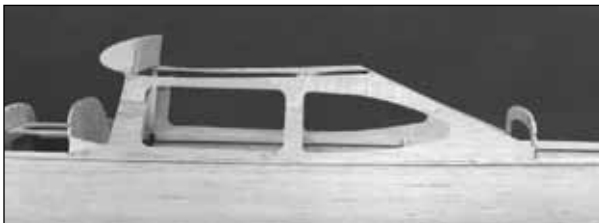

❑ 14. Align both Cabin Sides fore and aft on the Main Stringer between IP and F-5B. Fit the notch at the upper front corner of the Cabin Side *wing roots* to the tabs at the top of F-2B. Glue the Cabin Sides to the Main Stringers, F-2B and F-3B, **but not to the Wing Saddle Brace**.

❑ 15. Press down on the middle of the Wing Saddle Brace until it is about 1/16" below the top edge of the Cabin Side, then wick thin CA along the seam to hold it in position. When cured, add a fillet of medium CA to the joint to secure it in place. *This depression will allow for the addition of Foam Wing Saddle Tape and minor adjustment to the wing's alignment if needed.*

❑ 16. Repeat Step 15 for the other side of the fuse. Sand the edge of the Cabin Sides flush with the Rear Window Frames.

❑ 17. Use 30-Minute Epoxy to glue the 3/8" x 7/8" x 1" hardwood **Wing Bolt Blocks** into the pockets of the Wing Saddle Braces and to F-3B. Make sure that you obtain a solid bond between all parts. Turn the fuse upside down and **add a fillet of epoxy** around the edges of the Wing Bolt Blocks **under** the Wing Saddle Braces.

### ***Install nose gear steering***

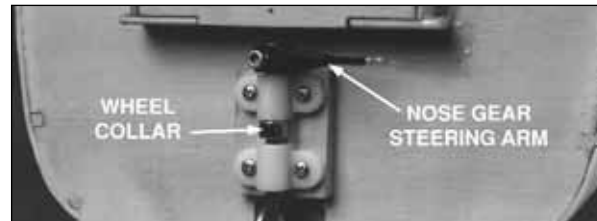

❑ 1. Install a 3/16" **Wheel Collar and Set Screw** on the Nose Gear Wire, between the upper and lower parts of the Nose Gear Bearing. The top end of the Nose Gear Wire must protrude 3/16" above the top of the Bearing. Install the **Nose Gear Steering Arm** on the top end of the Nose Gear Wire as shown. Use a 6-32 x 1/4" **Socket Head Cap Screw** to secure the Nose Gear Steering Arm in position, angled 1-1/8" forward of F-1 when the wheel's axle is parallel to F-1. *See plan bottom view for angle.*

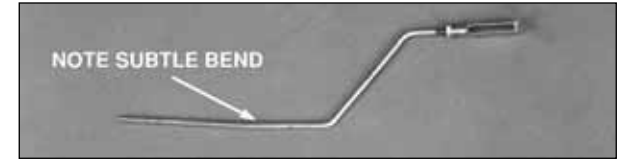

❑ 2. Cut 1/2" from the **threaded end** of the 4-40 x 12" **Nose Wheel Steering Pushrod** wire. File off any burrs from the cut end. Screw a 4-40 **Hex Nut** and **Metal Clevis** onto the Pushrod. Use the pattern on the plans to bend the Pushrod as indicated, but don't cut off the excess yet.



❑ 3. Drill a 3/32" hole through the outer hole of the Nose Gear Steering Arm. Insert the **heavy-duty Screw Lock Pushrod Connector** up from the bottom of the Nose Wheel Steering Arm, then secure it with a Star Washer. Insert the unthreaded end of the Pushrod through the Connector toward F-1. View the fuse from above to align the Pushrod with the rudder servo, then mark F-1 using the Pushrod as a punch.

❑ 4. Drill a 3/16 hole through F-1 on the mark you just made.



❑ 5. Hook up your radio and **check that the rudder servo is centered**. Cut the Pushrod to

its correct length, then insert it from the servo location through F-1 into the Connector on the Nose Wheel Steering Arm. Clip the Metal Clevis onto the servo horn. Align the servo horn and Nose Wheel Steering Arm as shown on the plans. Secure the Pushrod in the Quick Connector with a 4-40 x 1/4" Socket Head Cap Screw.

❑ 6. When the Nose Wheel Steering Arm is adjusted, remove the Nose Gear Wire. File a flat spot where the steering arm locking screw contacts the wire so the steering arm can be locked in position.

## Install engine and tank

Depending on your choice of engine, 2-stroke or 4-stroke, you may have to be a little inventive for throttle, tank and muffler hookup. The installation of a 2-stroke .60 to .90 size engine is pretty straightforward. Use the servo locations provided on the Servo Tray, mount the tank sideways as shown, and use a Top Flite In-Cowl Muffler (TOPQ7916). Some 4-stroke engines allow the throttle linkage to be rotated 180 degrees, thereby permitting the same servo setup as a 2-stroke engine. *The O. S. .91 Surpass is one such engine.*

This model flies very well on an O. S. .61 SF 2-stroke engine. As the .61SF also allows for the most "sterile" setup with everything contained in the cowl, we will detail its installation. *We have also included instructions for those who prefer to use one of the larger 4-stroke engines.*



❑ 1. Remove the spacer bar from the back of both Engine Mount halves and trim off any burrs. Snap the Engine Mount halves together and place the engine of your choice between the rails, adjusting the width between the rails accordingly.

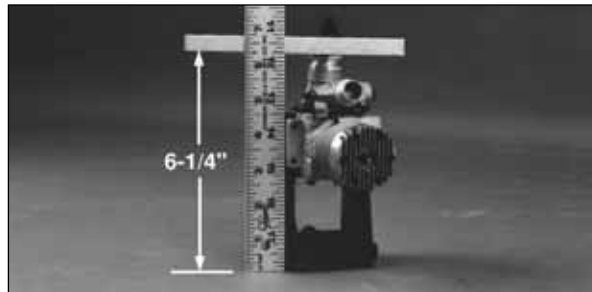

❑ 2. Position the engine so that the propeller backplate is exactly 6-1/4" (159 mm) from the aft edge of the Engine Mount. Mark, drill and tap the engine mounting holes to accept the 8-32 socket head cap screws included with this kit.



❑ 3. Install the Engine Mount on the Firewall as shown with four 8-32 x 1-1/4" Socket Head Cap

Screws, #8 Flat Washers and #8 Lock Washers. Use the index marks on the Firewall to center the Engine Mount.

**NOTE: We strongly recommend that ALL engines be mounted horizontally to provide enough cooling airflow over the cylinder via the normal cowl air inlets.**

❑ 4. Bolt the engine to the mount.

***If using the optional Top Flite In-Cowl Muffler and Header, perform the following step:***

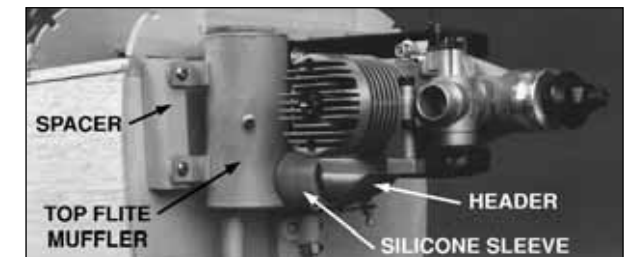

❑ 5. Bolt the Top Flite Header (not included) to the engine. Use the Silicone Sleeve to attach the Top Flite In-Cowl Muffler (not included) to the Header. Make a spacer block for the muffler from scrap. **NOTE: Do not use balsa.** Use epoxy to glue the spacer block to F-1 in line with the muffler mounting lugs. Shorten the muffler or header connection tubes if required, so that the muffler can be screwed to the spacer using the supplied screws and silicone washers.

❑ 6. Drill a 3/16" hole through the Firewall in line with the servo and throttle arm on the engine. **Keep the hole close to the level of the servo tray** so that the pushrod will be able to pass under the Fuel Tank.

**NOTE:** Due to the variety of hook-up methods preferred by different modelers, we do not provide any throttle linkage hardware in most of our kits. However, we do offer the following method as one that works well. You probably have the materials buried somewhere under your workbench.

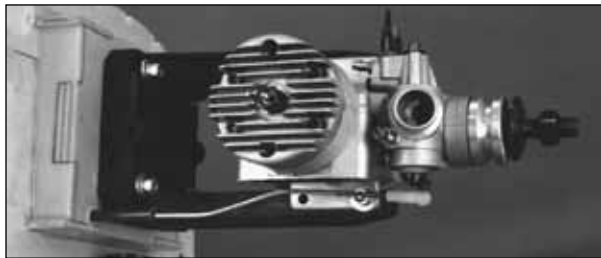

□ 7. Insert a short length of outer pushrod tube through the throttle hole in the Firewall. Attach a Ball Link to the throttle arm on the engine. Screw a Ball Link Socket onto a 2-56 x 12" threaded wire pushrod. Insert the pushrod through the outer pushrod tube, then attach the Ball Link and Socket. Bend a "dog leg" in the pushrod near the servo so that the wire will be just above the servo horn. Attach the pushrod wire to the servo with a small pushrod Connector. Connect the servo to your radio and adjust the pushrod length and position on the servo horn to obtain full throttle movement.

### SERVO OPTION FOR 1.20 ENGINE

To simplify the throttle hookup for a 1.20 4-stroke engine you may want to consider the following suggestion.



Use scrap 3/16" or 1/4" plywood to make two servo mounting blocks approximately 3/4" square. Use epoxy to glue these blocks as shown above the Fuel Tank Roof so that the servo horn aligns with the throttle arm on the engine. Use the same pushrod technique as described in Step 8 for a direct hookup. The down-side to this method is that the servo will not be accessible after sheeting without cutting into the top of the fuse...but, because servos are generally quite reliable, this may never be necessary.

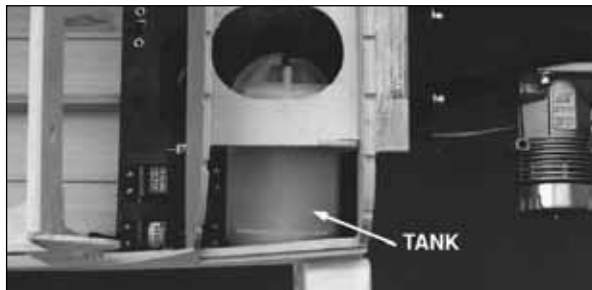

□ 8. Assemble a 12 oz. Great Planes Fuel Tank (GPMQ4105) with the right angled fuel pickup tube. The Tank is installed "sideways" under the Instrument Panel with the back end pointing toward the right side of the fuse. Work a small piece of 1/4" foam rubber above and below the Tank, then slide a couple of scrap balsa sticks under the tank to secure it in position and provide throttle pushrod clearance. We flew all of our test flights with the tank mounted in this position and experienced no problems.

□ 9. Mark and drill 1/4" fuel tube holes through the firewall, being careful not to damage the tank. Install both the fuel supply and pressure tubes. For ease of fueling we suggest a Great Planes Fuel Filler Valve (GPMQ4160) that can be mounted on the cowling during final assembly.

### Attach the stab and fin

□ 1. Check the fit of the Stab with the Stab Saddle. Make any adjustments to the Stab Saddle very carefully, so that you **don't change the built-in incidence angle**.

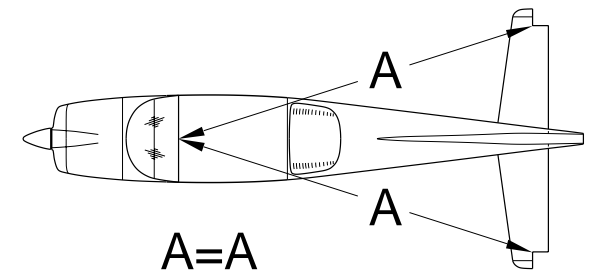

□ 2. Put the stab on the saddle and add a small weight to hold it in place. Place a 36" straightedge across the Wing Saddle and clip it to F-2B. Sight across the top of the Stab to the straightedge from six to ten feet behind the model. If both Stab tips are not equidistant below the straightedge, make **small** adjustments to the Stab Saddle to correct the problem. Use a string, pinned to the top center of F-2, to equalize the distance of the Stab tips.

❑ 3. When the Stab is aligned with the Fuse, draw light reference marks on the Stab to help you accurately reposition it after the glue has been applied.

❑ 4. Apply 30-Minute Epoxy to the **Stab Saddle**, then lay the Stab in place. Apply a weight to hold the Stab in position until the epoxy cures. Double-check alignment before the epoxy kicks off.

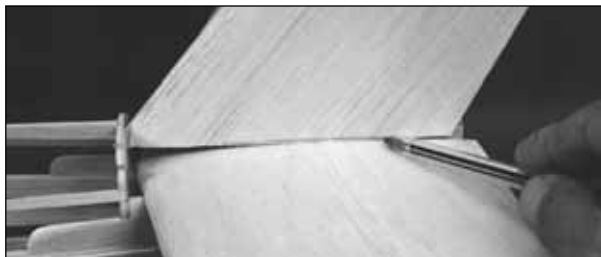

❑ 5. Hold the Fin on top of the Stab with the LE in the notch at the top of F-8B. Refer to the plans and you will see that the Fin TE is 1/8" forward of the Stab TE notch (see photo at step 7). Mark the bottom edge to show where fin sheeting needs to be trimmed to allow a **flush fit** with the Stab.

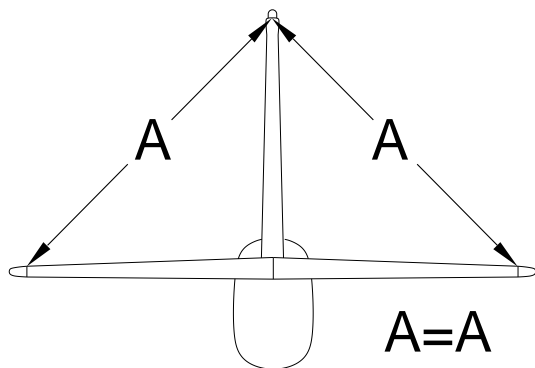

❑ 6. Put the Fin in position and sight it from 6 to 10 feet behind the model. If it is not vertical, make adjustments to the bottom edge a little at a time with fine sandpaper. When you are satisfied

with the fit, pin the Fin in position. Carefully measure from the Fin tip to the Stab tips to double check your "eyeball" method and to be sure that your sanding is accurate.



❑ 7. Mark the aft center of the Fin's TE on the Stab. This is where the Rudder Torque Rod will exit the Stab. Mark the location of the fin prior to removal for future realignment. Remove the Fin from the Stab.



❑ 8. Align the die-cut 1/8" ply **Fin Drill Guide** with the Fin center mark on the Stab as shown. Carefully drill a **3/16"** hole through the Stab into the rear of the fuse while keeping the drill bit aligned with the Fin Drill Guide.

❑ 9. Trim the threaded portion of the 1/8" bent wire **Rudder Torque Rod** so that 5/8" of thread remains. Screw the nylon Rudder Horn onto the threaded end until flush with the end of the threads.



❑ 10. Insert the Rudder Torque Rod through the hole in the Stab from inside the fuse. Try not to damage the Stab as the Torque Rod exits the hole. If satisfied with the fit and alignment, remove the Rudder Torque Rod and roughen up the surface of the plastic bearing tube with 100-grit sandpaper. **Coat the Torque Rod wire with petroleum jelly** at both ends of the plastic bearing tube. Coat the Plastic Bearing Tube with 6-Minute Epoxy, then reinsert it into the hole in the Stab. The Plastic Bearing Tube should protrude above the Stab about 1/16".

**NOTE: Before installing the Fin, we need to finish up the pushrod hookups so that the Fin won't be in the way when you turn the fuse upside down.**



❑ 11. Clean the aft ends of both wire pushrods with steel wool. Clean the ends with alcohol. Grip a pushrod with a pair of pliers, then push a **Coupling Sleeve** onto the wire halfway using another pair of pliers. Do the same with the other pushrod.



❑ 12. Screw a nylon **Clevis** onto a **2-56 x 4” threaded Pushrod** at least 14 revolutions. Slide a Silicone Retainer over the Pushrod, onto the aft end of the Clevis. Clip the Clevis onto the Rudder Torque Rod Horn and center the Torque Rod (i.e., neutral rudder). With the servo centered, position the 4” pushrod over the Split Coupling Sleeve, then mark it where it will just miss touching the other pushrod already in the Sleeve. Repeat this procedure for the Elevator.

❑ 13. Trim and **clean** (as you did during Step 11) the short Pushrods, then push them into the aft end of the Coupling Sleeves. Use **liquid Flux and Silver Solder** to solder the Pushrods into the Coupling Sleeves. If you haven’t done this operation before, read *Hot Tip for Silver Soldering*.



### HOT TIP FOR SILVER SOLDERING

Use this process when soldering metal to metal, such as brass tube to wire, or pushrod ends to wire.

A. Thoroughly clean the items to be soldered with alcohol or degreasing solvent. Pay special attention to the **inside** of the Threaded Brass Couplers.

B. Roughen the area to be soldered with fine sandpaper, then clean again.

C. Assemble the items to be soldered.

D. Apply a small amount of soldering flux. Acid based liquid flux works best when one or more of the items is steel.

E. Heat the metal with a soldering gun or iron, and apply solder to the metal. The metal must get hot enough to melt the solder and the solder must flow freely into the joint.

F. Do not move the parts until the solder has cooled.

G. Test the joint by pulling hard.

H. Clean off the excess flux with alcohol or solvent. Coat the parts with a very fine film of oil.

*Now that most of the fiddly work is finished, clean up your bench and let’s get back to what many people consider “the fun stuff”—finishing the airframe.*

❑ 14. If you are installing a beacon light on the Fin, drill a hole through the Stab that matches the location of the conduit you installed earlier.

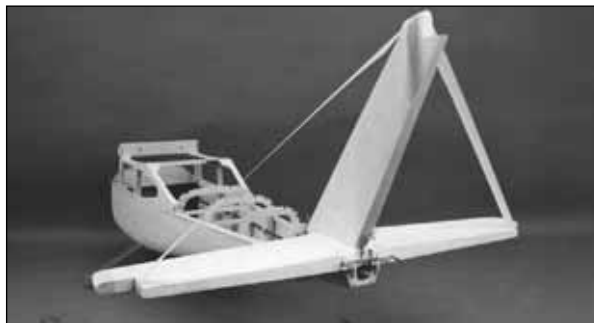

❑ 15. Mix up some 30-Minute Epoxy and add a

dash of microballoons to “thicken it up” and create a fillet. Apply the epoxy mixture to the LE, TE and bottom of the Fin. Align the Fin, and press it into position. Use masking tape to hold it in position while the epoxy cures. Once the tape is in place, check the Fin to make sure that it’s on the fuse centerline **and** perpendicular to the Stab. Use any leftover epoxy to form a small fillet around the base of the Fin.

### Complete the fuselage top

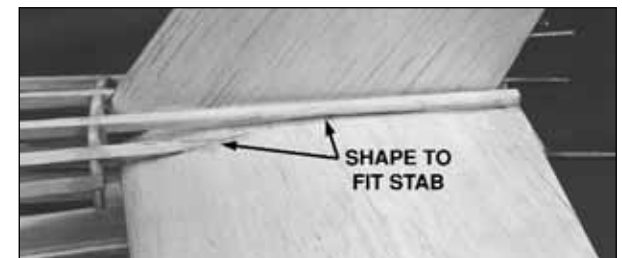

❑ 1. Cut 3/16” x 3/16” x 24” balsa Stringers to fit the top aft formers from F-5B to the top of the Stab. Taper the Stringers to blend with the surface of the Stab. Leave about 3/16” of **each** Stringer protruding **forward** of F-5B to provide a “ledge” for the rear window. Use thin CA to glue them in place.



❑ 2. Cut 3/16" square balsa Stringers to fit from F-1B to IP. Glue them in position with thin CA.



❑ 3. Use the pattern on the wing plan to cut an Upper Side Panel (not to be confused with Top Panel) from a 3/32" x 2-3/4" x 24" balsa sheet. The curved portion should be sanded for a snug fit under the Stab when the bottom of the sheet is on the Main Sub-stringer. Trim the length to fit flush with the Cabin Side and the aft end of the Stab. The top edge should bisect the stringer. Dampen the outside surface of the sheet, flex it to start a curve, then glue it in place with medium CA. Repeat this step for the other side of the fuse. **IMPORTANT:** Be sure to get a good glue bond between the sheeting and the bottom of the Stab.



❑ 4. Once again, use the pattern on the wing plan to rough cut the Top Panel from a 3/32" x 2-3/4" x 24" balsa sheet. This time, carefully

sand the aft areas to fit closely with the Stab and the Fin. Trim the length even with the overhanging stringers at F-5B. The Top Panel should bisect the top center stringer. Repeat this step for the other side. Use the chalk technique to mark the top center cut line.

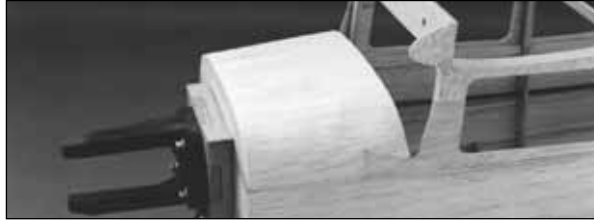

❑ 5. Use the off-cut pieces of 3/32" balsa from the lower fuse sheeting to sheet the area from F-1B to 1-1/2" **past the Instrument Panel**. The easiest way to do this small section is to make a "skin" by edge gluing three sheets together, then cutting them as a unit to fit over the front end of the fuse.



❑ 6. Refer to the shape of the Instrument Panel anti-glare shield on the plans, then carefully cut and sand the top forward sheeting to conform to this shape.

❑ 7. Sand off the protruding portion of the Main Sub-Stringer *ledge* from along both sides of the fuse with a T-bar or sanding block.

❑ 8. Draw a centerline from the middle of the Fin LE along the top of the fuse to F-5B. The tip of the center stringer may be used for reference. Use the plans as a guide to spot glue the die-cut 3/32" balsa **Dorsal Fin Former D-3** in position. It must be centered on the centerline you drew.

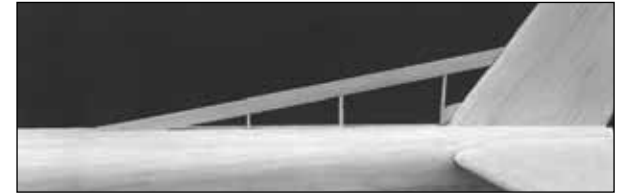

9. Measure and cut a 7/32" x 1/2" x 15" tapered balsa **Top Edge** stringer (leftover from the wing center section TE) to fit from the Fin's LE to the top of the fuse, as shown on the plans. Glue it in position. Slide die-cut 3/32" balsa **D-1** and **D-2** under the Top Edge stringer until they fit. Glue them in position.

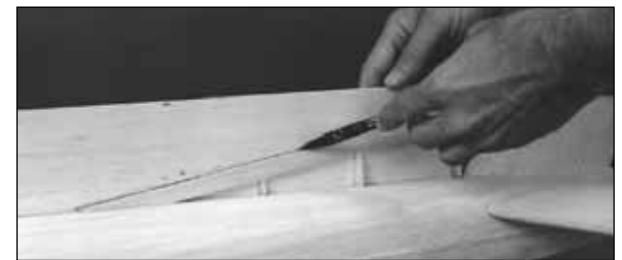

❑ 10. Hold a 1/16" x 3" x 30" balsa sheet against the Dorsal Fin framework and trace the outline, **allowing a little extra for sanding**. Bevel the aft edge to fit the curvature of the Fin at the LE. Glue the sheet to the Dorsal Fin's frame and to the fuse top sheeting being careful **not to build in any twists**. Repeat this step for the other side.

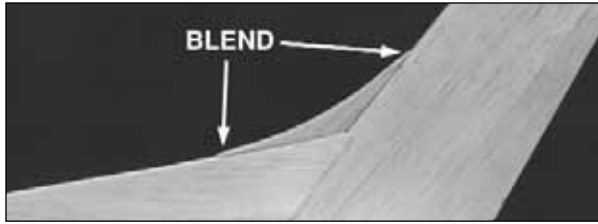

❑ 11. Sand the shaped 1/4" balsa **Dorsal Fillet** to blend with the top of the Dorsal Fin and the Fin's LE. Glue it in place, then sand it to blend with the two Fins. The result should be a smooth, constant radius, without any "bumps" on the ends.



❑ 12. Blend the Dorsal Fin to the Vertical Fin with **several thin coats** of balsa filler. The object is to have the whole Fin assembly appear as one flowing piece.

**NOTE: Do not make a fillet where the Fin assembly meets the fuse.**

❑ 13. While you have the balsa filler handy, take care of any dings and open seams between the sheeting.



❑ 14. Test fit the four segments of the die-cut 1/8" balsa **Cowl Ring** on F-1.

**NOTE: There are top and bottom pairs of parts to the Cowl Ring. Glue the Cowl Ring to F-1 with thick CA, so that you will have a few seconds to make last-minute adjustments. The Cowl Ring should be inset from the fuse sheeting by about 1/16" all around.**



❑ 15. Use 30-Minute Epoxy to glue each of the 1/2" x 1/2" x 5/8" Maple **Cowl Mount Blocks** into the notches around the Cowl Ring. As Cowlings are usually subjected to a fair amount of vibration, be sure to get a good bond between the Blocks, the Cowl Ring and F-1.



❑ 16. Glue the two 1/32" x 3/8" x 4-5/8" birch ply strips to the forward sides of F-2B. They extend from the Main Stringer to the top of F-2D and provide a little extra support for F-2B.

*By now you should be looking at a Cessna. If not, you've been working on the wrong kit.*

### **Mount the wing to the fuselage**

❑ 1. Clean out wing dowel holes with a 1/4" drill bit, to assure easy wing dowel fits.

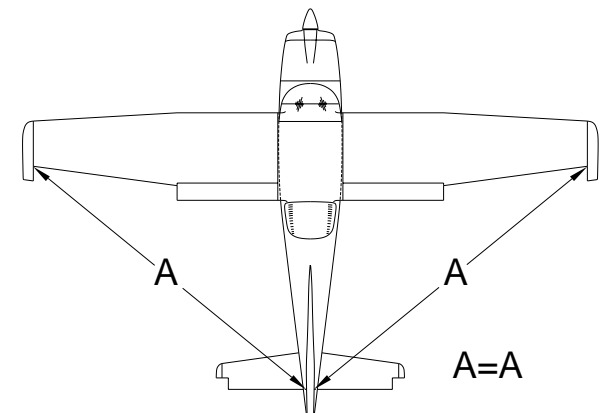

❑ 2. Install the wing and check the fit. Make adjustments as necessary. Hold a string (with

one end attached to a pin centered at the tail) out to a wing tip. Put a piece of tape on the string to mark the intersection of the string and the wing tip. Swing the string over to the other wing tip and check to see if the distances are the same (see diagram). Adjust the position of the trailing edge of the wing until the wing is properly aligned.

**NOTE: Make sure the wing is held securely and cannot shift while you are drilling the mounting holes.**

❑ 3. **Lightly** mark the center of the wing mount holes on the Mounting Blocks, with a **1/4" drill bit** inserted through the Bolt Plates in the wing. Do **not** drill through the Mounting Blocks with the 1/4" Bit.

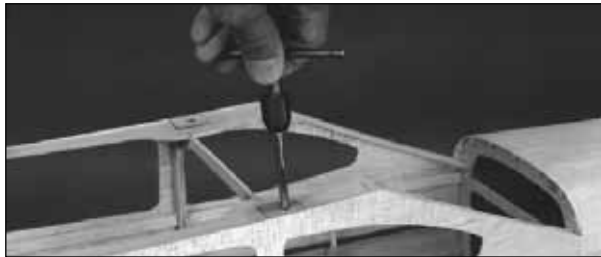

❑ 4. **Remove the wing** and drill the holes with a **#10** (or 13/64") drill bit through the wing mount blocks. Keep the drill as vertical as possible. Tap the holes with a **1/4-20 tap**. Add a couple drops of thin CA to the holes to harden the threads, then re-tap the holes after the CA has fully cured.

❑ 5. Bolt the wing in position with **1/4-20 x 2" nylon Wing Bolts**. *The nylon Wing Bolts may be shortened to 1-1/2" if desired.*

## HINGE THE CONTROL SURFACES

**NOTE: Hinging is usually done after covering and painting; however, because the control linkages will be enclosed in the fuse, you should temporarily install the hinges WITHOUT using CA so that the clevises can be adjusted. The hinge locations are shown on the plans.**

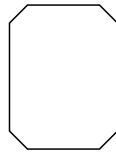
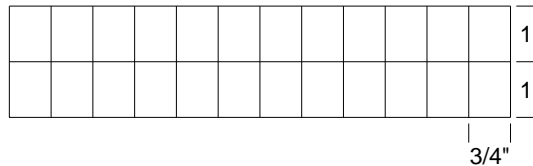

❑ Cut 15 hinges (3/4" x 1") from the 2" x 9" CA hinge strip. Trim the corners at a 45 degree angle to make insertion easier.

### Hinge the elevator

❑ 1. Use a **#11 blade** in a hobby knife to cut matching hinge slots in the Stab and the Elevators at the locations shown on the plans. Test fit the Elevators to the Stabilizer with all hinges **and** the wire joiner in place. Make sure both Elevators are set at the same angle. Make adjustments to the joiner wire and pushrod length if necessary.

**Do steps 2 and 3 AFTER the model has been covered.**

❑ 2. Chamfer the ends of the joiner wire slightly with a file. Roughen the "arms" with coarse

sandpaper. Clean the "arms" thoroughly with rubbing alcohol. Work a generous amount of 30-Minute Epoxy into the wire joiner holes in the elevators.

❑ 3. Work the elevator hinges into the stab and, as you do this, insert the wire joiner all the way into the elevator holes. Wipe away any excess epoxy. Glue the hinges in place using 4-6 drops of thin CA on **both sides of each hinge**.

### Hinge the rudder and ailerons

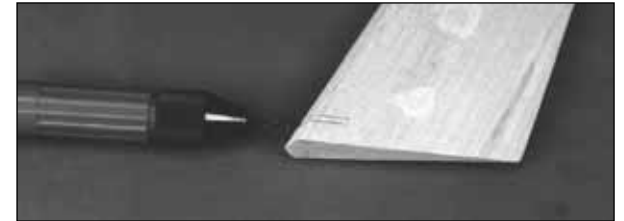

❑ 1. Hold the Rudder against the Fin. Mark the location of the Torque Rod *tiller* on the LE of the Rudder. Drill a 9/64" hole into the Rudder LE that is in line with the Torque Rod *tiller*. A hand-turned *Pin Vice* is a good tool for this purpose.



❑ 2. Cut a 9/64"-wide groove from the bottom of the Rudder to the tiller hole. Ream out the groove with a 9/64" drill bit or round file. Insert the Torque Rod tiller into the hole, then seat the Rudder against the Fin TE. Make whatever adjustments are necessary to align the Rudder in the neutral position. Double check that the servo is centered.

- ❑ 3. Install three hinges in the Rudder and Fin assembly.

**Do steps 4 and 5 after the model is covered.**

- ❑ 4. Pack 30-Minute Epoxy into the tiller hole in the Rudder, then install the Rudder in the same manner as the Elevators.

- ❑ 5. Hinge the **Ailerons** using the same technique as the Elevators and Rudder, but without the torque rod insertion steps.

**THERE SHOULD BE NO HINGE GAP**

## FUSELAGE FINISHING TOUCHES



- ❑ 1. Bevel the 3/4" x 3" x 6" balsa **Lower Aft Fuse Block** to fit flush with F-8. Glue the Block to the stringers and to F-8. Use a razor plane and sanding block to shape the Block to blend with the shape of the Fuse.



- ❑ 2. Trim the left and right ABS plastic **Tail Cone** halves to the cut line, then sand the edges smooth. Glue the two halves together with thin CA. Hold the Tail Cone up to the aft end of the Fuse and mark the location of the elevator joiner wire on each side. Notch out the Tail Cone to allow the joiner wire to fit through it. Use thick CA to glue the Tail Cone in position.

- ❑ 3. Blend the Tail Cone to the Fuse by roughening the plastic with coarse sandpaper, then applying balsa filler around the joint. When the filler is dry, feather the edges with a sanding block.



- ❑ 4. Sand a 1/32" recess around the protruding top sheeting at F-5B so that the Butyrate Rear Window will fit flush with the fuse top. *Several layers of masking tape wrapped over the top sheeting makes a handy guide for sanding even channels such as this.*

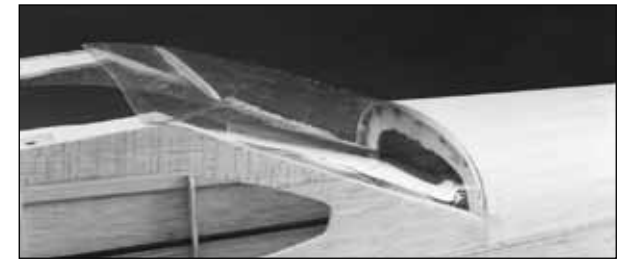

- ❑ 5. Trim the Butyrate Rear Window to the embossed cut lines. Test fit the Rear Window and make adjustments as needed with a sanding block and 220-grit sandpaper.

- ❑ 6. Roughen the inside edges of the Rear Window where it will contact the fuse, then glue it in position with RC-56 glue or 6-Minute Epoxy.

- ❑ 7. Use balsa filler to feather the Rear Window into the fuse after the glue has cured. (See directions for Step 3.)

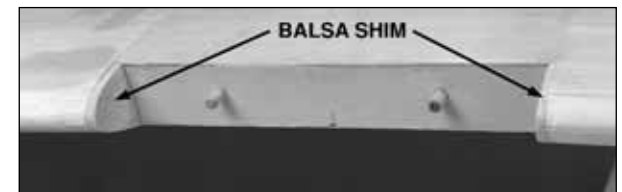

- ❑ 8. Install the wing then fit a 1/4" x 1-5/8" x 1-5/8" balsa shim on each inboard wing root to fill the gap between the Wing and the Cabin Sides. Leave about a 1/16" gap on both sides, to allow for the thickness of the Front Windshield.

## Assemble the cowl

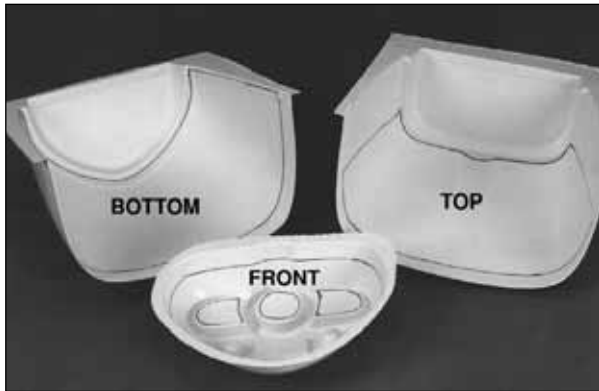

❑ 1. Use a **new # 11 blade** in a hobby knife to **score** around the *cutlines* inside all three parts of the ABS cowl as shown in the photo. Flex the ABS along the scores until the excess material breaks free. Use a Moto-Tool and cutting burr to cut the air intakes and propshaft opening.

❑ 2. Use a sanding block to clean up the edges and to make any adjustments that may be needed for a nice flush fit. Roughen the inside edges of the joints with coarse sandpaper, then fit the three parts together and secure them with tape. Carefully wick thin CA around the joints and allow the parts to cure. Do **not** use CA accelerator.



❑ 3. For added strength, epoxy 1"-wide fiberglass cloth tape across all of the seams on the inside of the cowl.

**IMPORTANT: Hot air generated by the engine MUST be vented from the cowl or your engine will overheat and quit!** While we experienced no overheating problems with our **engine running slightly rich** and both air inlets open, you may prefer **not** to open **both** air inlets. By leaving only the inlet in front of the cylinder open, more air is forced directly over the cylinder and out through the cowl flaps. If you choose to open the second inlet, a dummy cylinder head or baffle could be installed behind the opening to restrict the air-flow into the cowl.



❑ 4. Use a hobby knife to cut along the embossed lines on the inside of the cowl for the cowl flap openings. Use the patterns on the plans to cut the cowl flap sides from excess 1/16" ply leftover from the servo hatch die-cut sheet. Cut out the **cowl flaps** from the ABS sheet, using the cut lines for reference. Glue the cowl flap sides to the inside edges of the cowl, then center the flap across the sides and glue it in place.

❑ 5. Fill the seams on the outside of the cowl with *Bondo*® type automotive body filler.

## Fit the cowl to the fuselage and engine

❑ 1. Mount the engine. Slide the Cowl into position as far as it will fit. Cut a slot in the Cowl for the Nose Gear. Sand the hardwood Cowl Mounting Blocks and balsa Cowl Ring until the Cowl fits flush with the fuse. With the cowl in position, install a spinner on the prop shaft and check the clearance around the front of the Cowl. Sand the aft edge of the Cowl until the spinner is centered and is 1/16" away from the front of the Cowl.



❑ 2. Draw a short line to extend the centerline of each Cowl Mounting Block onto the forward edge of the balsa sheeting.

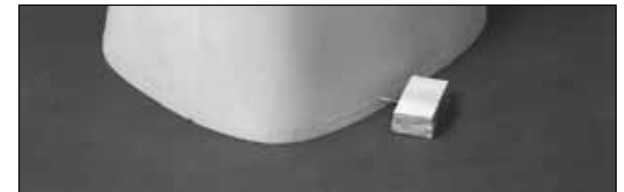

❑ 3. Sandwich a T-pin between two scraps of 1/4" balsa to make a quickie height gauge. Glue the top to the bottom piece of balsa with CA. Hold the height gauge and the Cowl flat on the work bench, then rotate the height gauge around the perimeter of the cowl to **lightly** scribe a line.

**NOTE: A pen or pencil may be substituted for the "Pin" so long as the point is 1/4" above the work surface.**

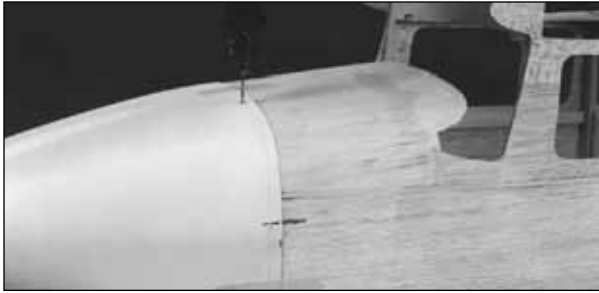

❑ 4. Tape the Cowl on the front of the fuse. Extend the centerlines you drew in step 2 forward to the line on the Cowl. Drill 1/16" pilot holes into the Cowl Mounting Blocks at each intersection. Remove the Cowl and enlarge the holes in **only the Cowl** to 3/32".

❑ 5. Install the needle valve. If you will be using a 4-stroke engine, install the choke control wire as well.

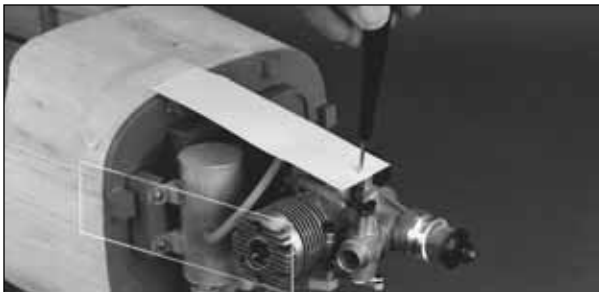

❑ 6. Use thin cardstock or a file folder to make **location templates** as shown in the photo. In the case of a 2-stroke engine you will need templates for the glow plug access, needle valve and muffler exhaust. Larger 4-stroke engines will also require a template for the cylinder head and choke button. Tape these securely to the fuse behind F-1.



❑ 7. Remove the control extensions (and 4-stroke engine if that is what you have chosen) but leave the templates in place. Slide the cowl under the templates and fasten in position with #2 x 3/8" sheet metal screws. Use a pen to trace the openings on the cowl. Remove the cowl, then use a Moto-Tool and grinding stone (or power drill and a round file) to cut the openings.

❑ 8. Put the engine back on the mount with a couple of screws, then check the fit of the cowl openings. Make adjustments as necessary, a little at a time.

❑ 9. Drill a 3/8" hole in the cowl between F-1 and the engine's carb to install an optional fuel filler valve (GPMQ4160).

### ***Assemble and install wheel pants***

❑❑ 1. Trim the upper and lower **Wheel Pants** to the cut lines. Sand the edges smooth with 150-grit sandpaper.

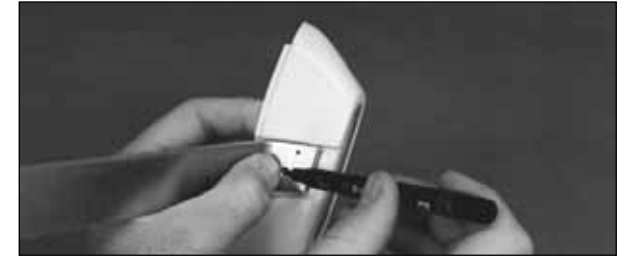

❑❑ 2. Position a Main Landing Gear strut in the recessed portion of the lower section of the Wheel Pant, **5/16" above the bottom edge**. Mark the axle hole through the Landing Gear.

❑❑ 3. Drill a **3/16"** hole through the mark you just made and also through the **index mark** on the 1/16" die-cut birch ply **Axle Support**.

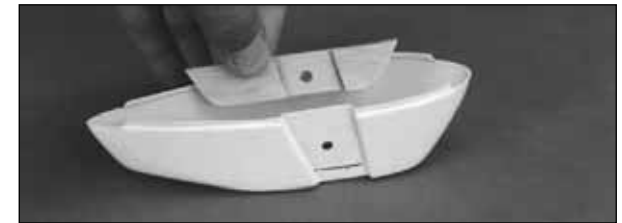

❑❑ 4. Glue the 1/8" die-cut balsa **Wheel Pant Spacers** to the ply Axle Support as shown. Test fit the support assembly inside the Wheel Pant, then sand the balsa Spacers to match the contours of the Wheel Pant.



❑❑ 5. To align the support assembly, insert the 8-32 x 1-1/2" **Axle Bolt** through the hole in the Wheel Pant. Slide the support assembly onto the bolt and glue it in position to the inside of the Wheel Pant with medium CA.

❑❑ 6. Roughen the mating area of both Wheel Pant halves with coarse sandpaper. Tape the upper half of the Wheel Pant in position, then wick thin CA around the seam. Remove the tape and fill the seam with Bondo®. Sand the Bondo when it has hardened.

**NOTE: Remove the Landing Gear from the model to do the next several steps.**



❑❑ 7. Trim the ABS upper and lower **Landing Gear Fairings** to the cut lines. Cut a slot in both parts to fit at the top and bottom of the Landing Gear as shown. Slide them onto the Landing Gear strut but don't glue them in position yet.

❑❑ 8. Assemble the Axle and 3-1/4" wheel as shown in the photo. The Hex Nut should not inhibit free rotation of the wheel.



❑❑ 9. Insert the Axle through the hole in the wooden support assembly, then screw it into the Landing Gear strut. (**Hint:** Grind a screwdriver slot in the threaded end of the axle bolt.) Screw another 8-32 hex nut onto the Axle bolt from the other side of the Landing Gear strut, locking the

axle in place. Check that the wheel still rotates without binding. Put a drop of thin CA on the outer hex nut to lock it in place.

❑❑ 10. Install the Main Landing Gear, then slide the upper Fairing into contact with the Fuse. Sand the Fairing edges to obtain a good fit with the curvature of the Fuse. Put a small amount of 6-Minute Epoxy **inside the Fairing where it touches the Landing Gear strut**, then slide it back into contact with the Fuse. **Do NOT glue the Fairing directly to the fuse** as it must be able to flex with the Landing Gear and also allow you to remove the Landing Gear strut for maintenance if needed.

❑❑ 11. Align the bottom edge of the Wheel Pants with your workbench, with the model in a level attitude. Screw a #2 x 3/8" sheet metal screw through the small hole next to the Axle into the Wheel Pant to hold it in alignment.



❑❑ 12. Slide the lower Landing Gear Fairing down until it touches the Wheel Pant. Wick thin CA around the edges to attach it to the Pant. Fill in the bottom edge recess with Bondo and sand it smooth.

❑❑ 13. The ABS Nose Gear Wheel Pant assembles in the same manner as the Main Landing Gear Pants, but has no inner support assembly. Cut out the opening on the bottom for the wheel. Drill a 3/16" hole for the axle wire.



❑❑ 14. Insert the Nose Gear Wire into the axle hole. Slide a 3/16" wheel collar onto the wire from the inside followed by a 2-3/4" wheel followed by another wheel collar. Center the wheel and tighten the wheel collar set screws. Apply a liberal coating of 6-Minute Epoxy to the recessed gear wire to hold it in place.

**NOTE: Before installing the Nose Gear Wire clean it with rubbing alcohol and roughen the section that will be glued to the wheel pant before installing it.**



15. Fill the joint seam and the Nose Gear wire recess with Bondo®.



16. **OPTIONAL:** We added a short section of a Robart dummy oleo strut to our prototype to give a more scale appearance.

## Install wing struts and fairings

**NOTE: See the wing plan for a view of the strut ends.**

☐☐ 1. Poke a T-pin through the hole you drilled in the Wing Strut Mounting block out through the Fuse side. Remember? You glued them behind F-2 at the lower corner of the Fuse.

☐☐ 2. Measure and cut two shaped Wing Struts to fit between the pin points and the Strut attachment blocks buried in the wing. Bevel the two ends to fit closely to the Wing and the Fuse.

☐☐ 3. Trim the ABS Wing Strut Fairings to the cut lines. Cut an airfoil shape to match the Strut in the ends of a pair of Fairings. Slide the Fairings over the Strut and check the fit between the Wing and the Fuse. Use a round file or Moto-Tool and sanding drum to shape the outside ends of the Fairings to blend with the Fuse and the Wing.

☐☐ 4. Center the lower Fairing over the pin point and tape it in position around the edges. While holding the Strut in approximately the correct position, tack glue the lower Fairing to it with a drop or two of CA.

☐☐ 5. Center the upper Fairing and Strut over the mark you made during "Wing Construction", then tack glue it to the Strut.

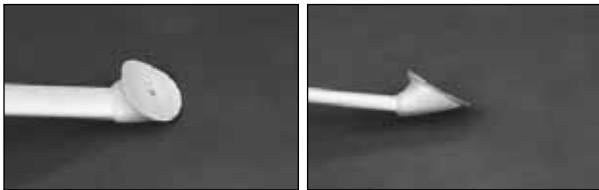

☐☐ 6. While holding the Strut in a vise (or

propped up so it can't fall over) fill the Fairing cavity to the brim with a 30-Minute Epoxy and microballoon mixture. When the epoxy has cured, fill the other end in the same manner.

☐☐ 7. Grind or file the epoxy filler to match the Fuse and Wing contours.

☐☐ 8. Tape the Strut assembly in position. Carefully drill a 1/16" diameter hole in the mounting block, perpendicular to the Fairing. If you miss the Mounting Block, adjust the drill angle and try again. Enlarge the correct hole in only the Fairing to 1/8". Drill a countersink recess about 1/8" deep x 3/16" diameter to accept a #4 x 3/4" sheet metal screw at each Fairing attachment point.

## FINISHING



### Final sanding

Nearly every imperfection in your wood structure will show through the covering material; therefore, before covering, you should make a final check of the entire structure. Fix any "dings," then sand the entire structure smooth, using progressively finer grades of sandpaper.

## Fuel proofing

Fuel proofing may be done after covering.

☐ 1. Fuelproof the engine compartment, paying special attention to the firewall. Either Grey (mix black and white) K&B epoxy paint or 30-Minute Epoxy is recommended.

☐ 2. Fuelproof any external exposed wood (eg: flap pushrod exits). Matching brush-on K&B or Perfect Paint works nicely here.

## Balance the airplane laterally

**SPECIAL NOTE: Do not confuse this procedure with "checking the C.G." or "balancing the airplane fore and aft." That very important step will be covered later in the manual.**

Now that you have the basic airframe nearly completed, this is a good time to balance the airplane **laterally** (side-to-side). Here is how to do it:

☐ 1. Temporarily attach the wing and engine (with muffler) to the fuselage.

☐ 2. With the wing level, lift the model by the engine propeller shaft and the fin post (this may require two people). Do this several times.

☐ 3. If one wing always drops when you lift the model, it means that side is heavy. Balance by gluing weight to the other wing tip.

**NOTE: An airplane that has been laterally balanced will track better in loops and other maneuvers.**

## Cover the structure with MonoKote®

The Cessna 182 does not require much painting to obtain the scheme shown on the box as most of the finish is done with Top Flite MonoKote. The only painting that is required are the plastic parts such as the cowl, wheel pants, fairings and wing struts. There are many other schemes used on Cessnas but the one shown on the box has proven to be highly visible in the air and is “scale.”

The technique we will describe here is the how the model pictured on the box was finished. In general, it involves covering most of the model with MonoKote, then priming and painting the cowl and surface details. Make sure the structure is smoothly sanded with **320-grit** sandpaper. Remove all dust from the structure so the MonoKote will stick well.

Cover the aircraft with MonoKote using the sequence below. Make sure the MonoKote is thoroughly stuck down to the structure and all of the edges are sealed. Use a **Top Flite MonoKote Hot Sock** on your covering iron to avoid scratching the MonoKote.



You can practically eliminate wrinkles caused when the model is left out in the sun or in the back of your car by following this technique used in the **Top Flite** model shop.

1. Cover your sealing iron with a **Top Flite Hot Sock** and turn the heat about 3/4 of the way to the high setting.

2. Say we are going to cover the Stab — Cut a

piece of MonoKote film about 2” larger than the area to be covered. Strip off the backing and position the film. Tack the film down **smack dab in the middle of the Stab.**

3. Pull (as in stretch) the film toward the tip, sealing it to the balsa from **the center out to the tip.** Work out any **wrinkles and air pockets** as you proceed with a combination of circular and back and forth motions.

4. Do the same procedure working the **opposite direction** from the center.

5. Pull and seal **diagonally toward the four corners**, always starting from the center. The trick is to shrink out any wrinkles before you seal the film to the surface.

6. Use a heat gun to heat and stretch the film around curved surfaces like the stab and rudder tips, while pulling on the excess material. You may need to pull hard to get out all of the wrinkles, so wear a glove if you need to. Follow-up the heat gun with your sealing iron to secure the bond.

The idea behind this approach (which can be applied to any part of the model) is to **pre-stretch the MonoKote** as it’s applied, and remove the air pockets that can expand later which cause the sags and wrinkles.

**NOTE:** When covering areas that involve sharp junctions, (like the tail section) cut narrow strips (3/8” to 1/2”) and apply them in the corners **before** covering the major surfaces. The larger pieces of MonoKote will overlap and capture these smaller pieces. This technique also bypasses the need to cut the MonoKote in these areas after it has been applied.

**DO NOT, under any circumstances, attempt to cut the covering material after it has been applied to the Fin and Stab, except around the leading and trailing edges and the tip. Modelers who do this often cut through the covering and part-way into the balsa stab skin. This can weaken the stab to the point where it may fail in flight!**

## Recommended covering sequence

1. Tail Junction Strips (See note above.)
2. Rudder, left side
3. Rudder, right side
4. Bottom of elevators
5. Top of elevators
6. Stab bottom
7. Stab top
8. Fin, left side
9. Fin, right side
10. Fuse bottom
11. Fuse sides
12. Fuse top
13. Ends of ailerons and flaps
14. Bottom of ailerons and flaps
15. Top of ailerons and flaps
16. TE surfaces of wing (at ailerons and flaps)
17. Bottom of left wing panel
18. Bottom of right wing panel
19. Bottom of center panel (overlap covering 1/4” at the outer panels)
20. Top of left wing panel (overlap covering 1/4” at wing LE)
21. Top of right wing panel (overlap covering 1/4” at the LE)
22. Top of center wing panel (overlap covering 1/4” at the outer panels)

## Painting

### Paints used on the prototype:

We used *K&B Super Pox* primer and color coat for all plastic and Butyrate parts.

### Surface Preparation

Mask the Rear Window with vinyl electrician's tape or Frisket® film (available at art supply stores). Mix **equal parts** of K&B primer, hardener and thinner, then stir the mixture well. Spray the **Cowl, Wheel Pants, Tail Cone, Rear Window Frame, Fairings** and **Wing Struts** with a **thin** coat of primer. Add a second coat of primer to areas that need it. Allow primer to dry overnight before sanding. Wet sand the primer with 320 and 400-grit sandpaper using a block where possible. Most of the primer should be sanded off.

### Apply the colors

We sprayed the parts with K&B Super Pox. We custom mixed the paint to match the Dark Red MonoKote by adding a little Yellow and Black to their standard Red color. Keep a swatch of MonoKote handy to test and compare the color on a regular basis. We used a few drops of Black and Blue mixed with White to match MonoKote Gray.

**NOTE: All paints dry slightly darker than they appear while wet. Spray on the color coat when satisfied with the match.**

K&B paints are not difficult to use if you have spray equipment. Use equal parts of the mixed color paint (Part A) and gloss hardener (Part B), stir well, then thin the mixture with K&B thinner so that it can be sprayed. Use about 33 percent of the total volume of parts A and B combined, of K&B thinner.

We painted all Landing Gear assemblies intact. The wheels were masked off with paper stuffed into the Wheel Pants. By painting the Landing Gear in this manner, all the parts blended together much better than if we had painted them separately.

### DRAW DOOR AND HATCH OUTLINES

For drawing the door and baggage compartment hatch outlines we used a **Staedtler® Lumocolor 313 Permanent** fine point pen. These pens are available from engineering/drafting supply stores. We suggest using this pen because it works well on MonoKote and mistakes can be removed with 70% rubbing alcohol. Your model may be cleaned with most cleaners without affecting the lines too badly. Remember, you can easily touch-up outlines by using this method.



**HOT TIP:** Place a sheet of clear butyrate plastic over the door and luggage hatch on the plans. Score them onto the plastic with a hobby knife. Bend the plastic along the score to break it off cleanly. Sand the corner radii with 320-grit sandpaper to smooth off any burrs. Lay the plastic template back over the plans and use a pen to trace the outline of the window frame for reference. Cut a hole in the center of the template so that you can tape it in position without having any tape extending over the edges.



Position the template on the fuse using the window as a reference point, then trace the door outline with a Staedtler pen. You will have to measure the location of the luggage hatch.

### APPLY THE DECALS

**NOTE: The decal sheet does not give you everything you need to completely trim your model, but it does provide all the intricate detailing and difficult items.**

1. Study the plans and the photos on the box to determine the location of individual decals.
2. Thoroughly clean your airplane before applying decals.
3. Trim the decals as close as practical. Carefully apply the decals to the model. You can float the decals into position by first applying soapy water (two or three drops of dish detergent to a quart of water) to the model's surface, then smoothing on the decal. Squeegee out excess water with a credit card wrapped with a tissue. Blot the surface dry and let the decal cure for at least 12 hours before running the engine.

**NOTE: Certain text decals are provided and may be used at your discretion. The "No Step" decals go on top of the main wheel pants.**

## Cockpit finishing

- ❑ 1. Sand the inside of the cockpit with 320-grit sandpaper. True up any uneven edges in the cockpit area.



- ❑ 2. Assemble and paint your pilots. We used 1/5 scale Williams Brothers pilots which required a 1" block under them to adjust their height. We glued and screwed our pilots to a piece of 1/8" light ply (not included) which was then screwed to a couple of blocks glued to the fuse sides.

- ❑ 3. Paint the interior of the cockpit flat black.

- ❑ 4. Install the **Instrument Panel Decal**. It may be applied directly to the existing panel.



For best results, stick the instrument decal to a scrap piece of 1/32" to 1/16" plywood, trim it to shape, then use spots of self-adhesive Velcro (hook and loop) to hold it in place.

- ❑ 5. Add any other cockpit details of your choosing at this time.

- ❑ 6. Trim the **Front Windshield** to the *cut-lines* then glue it to the model. We recommend using RC-56 glue or 6-Minute Epoxy to glue on the windshield, but if you have a favorite technique, use it. You should remove a small strip of MonoKote (if applicable) from under the windshield's frame for good glue adhesion. Use masking tape to hold the windshield in place while the glue sets.

- ❑ 7. Trim the **Side Windows** to fit the openings on both sides of the Cabin. Be sure to leave about 1/8" extra plastic around the perimeter for gluing. Test fit the Windows and trim the edges as necessary. Glue them to the inside of the Cabin Window Frame with RC-56 glue or epoxy.

### Install control surface corrugations



- ❑ 1. We made a cutting jig out of scrap ply to aid in trimming the ABS extrusions to the correct length for each surface.



- ❑ 2. Cut enough pieces of a specific length to do both sides of each control surface, then change the jig for the next length. Keep each piece close to the correct length (no more than 1/8") to avoid waste.

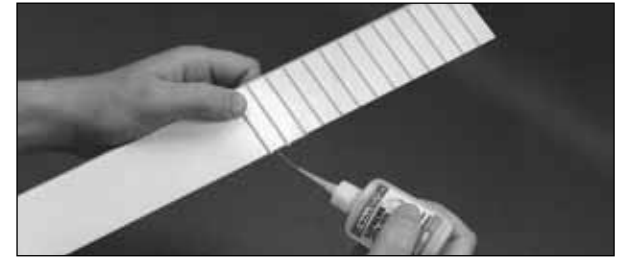

- ❑ 3. Use the plans as a guide to draw the location of each corrugation on the control surface, then, while holding the corrugation in position, place one drop of thin CA into the opening at each end.

- ❑ 4. Trim off any excess with a **single-edge razor blade**.

*Just for the record, the patience required to do this part of the model will be rewarded by an extremely realistic finish and a lot of "oohs" and "ahs" at the field.*

## A FEW WORDS ABOUT OPTIONAL LIGHTING

Scale lights make a model like this Cessna come to life. We added a rotating beacon, dual landing lights and position lights (see page 5 for part numbers). The rotating beacon is powered by a 9V transistor battery and a miniature circuit board that allows you to vary the “rotation” speed. The beacon and position lights are turned on via a simple toggle switch hidden within the cowling. The landing lights are powered directly from the flight-pack battery and are plugged into the receiver. By activating a sixth channel, we can turn the lights on and off from the transmitter. You could also “Y” the landing lights into the throttle or flap servo so when either is operated, the lights would come on.

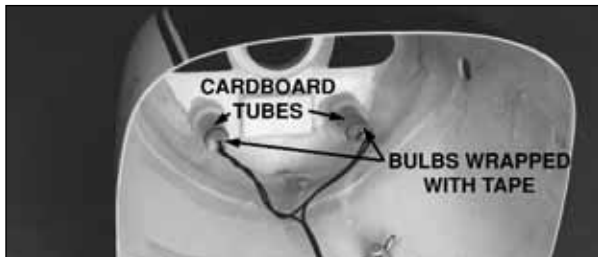

Pockets built-in to the cowl greatly simplify the installation of landing lights. The wiring was modified to include a “Deans” connector and a firewall-mounted plug so the cowling can be removed without having to cut the wires.

The circuit boards and 9V battery were wrapped in foam rubber and installed under the servo tray along with other electronic components.

## FINAL HOOKUPS AND CHECKS

### Flap/aileron control hookup



❑ 1. Epoxy the 5/16” x 3/4” x 7/8” hardwood **Servo Mounting Blocks** to the die-cut 1/16” ply **Flap and Aileron Servo Hatches**. Install the Flap and Aileron servos as shown in the photo and on the plans. After “fishing” the servo wires through to the opening at the center of the wing, plug them into a “Y” harness. Before permanently screwing the servo hatches in position, hook up your radio and set *centering* and *direction* of both sets of servos.



❑ 2. Drill 3/32” holes through the Servo Hatches at each of the six punch marks. Position the hatches in their respective openings, then drill 1/16” pilot holes into the **hatch support rails**. Use **#2 x 3/8” flat head sheet metal screws** to install the servo hatches.

❑ 3. Install the Aileron Horns in line with the pushrod exits as shown on the plans. Drill 1/16”

holes into the Ailerons at the proper horn locations. Screw the horns in place with **#2 x 3/8” sheet metal screws**.

**NOTE: Put a couple of drops of thin CA into each screw hole before reattaching the horns.**



❑ 3. Four .074 x 4” **Threaded End Rods** are supplied to make the **Flap and Aileron pushrods**. Screw a nylon **Clevis** and silicone **Retainer** on each pushrod. The Flap pushrods are connected to the servos using nylon **Faslinks™** as shown in the photo. Aileron pushrods are attached to the servos with **solder clevises**. Hook up and adjust the Aileron and Flap linkages. Refer to the **Control Surface Throws** section for movement recommendations.

❑ 4. **Permanently install** the Elevator (as described on page 42 in **Steps 3 & 4**) and the Rudder (page 43, **Steps 4 & 5**).

### Install receiver, battery and antenna

❑ 1. Wrap the Receiver and Battery in 1/2” foam rubber (Hobbico HCAQ1050) securing the foam with rubber bands.

❑ 2. Protect both components from fuel leakage by sealing them in plastic wrap or plastic bags. Seal the plastic closed with masking tape.

❑ 3. We installed a pushrod tube (not included in the kit) along the bottom inside surface of the fuse, to serve as a conduit for the antenna. The antenna was then inserted and pushed to the aft end of the fuse.

❑ 4. The Receiver and Battery may be “wedged” in place under the servo tray with additional layers of foam rubber.

❑ 5. Make sure the control surfaces move in the proper direction as illustrated in the following sketches:

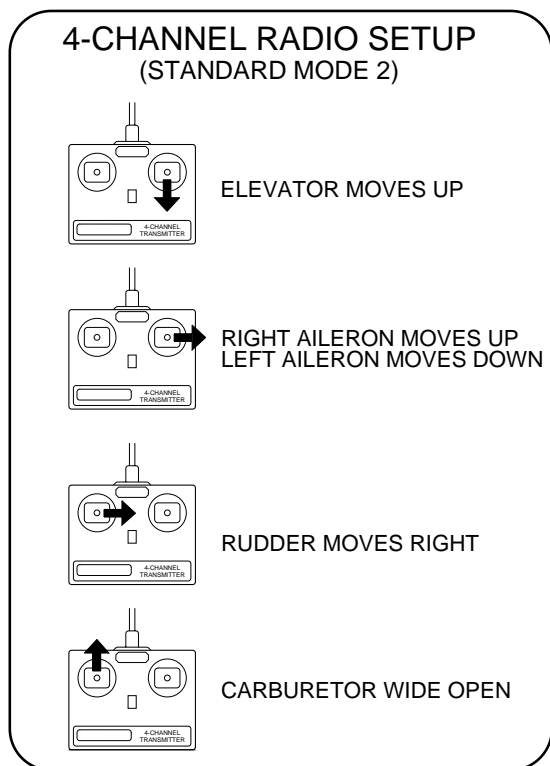

❑ 6. Adjust your pushrod hookups as necessary to provide the control surface movements shown.

## CONTROL SURFACE THROWS:

We recommend the following control surface throws:

**NOTE:** Throws are measured at the **widest part** of the elevators, rudder, and ailerons.

**NOTE:** If your radio does not have “dual rates”, then set up the control surfaces to move at the high rate throws.

**ELEVATOR:** (High Rate) 1-1/16" up  
1-1/16" down  
(Low Rate) 3/4" up  
3/4" down

**RUDDER:** (High Rate) 1" right  
1" left  
(Low Rate) 5/8" right  
5/8" left

**AILERONS:** (High Rate) 5/8" up  
5/8" down  
(Low Rate) 1/2" up  
1/2" down

**FLAPS:** (Takeoff) 1" down  
(Landing) 2" down

**TRIM MIXING:** If your transmitter is programmable for Flap to Elevator mixing we determined during our flight tests that attitude control was smoother with 3/16" of **down** Elevator trim at half Flaps and 3/8" of down elevator trim at full Flaps.

**NOTE:** The surface throws and balance for this aircraft have been extensively tested. We are confident that they represent the settings at which the Cessna 182 flies best. Please set up your aircraft to the specifications listed above. If, after a few flights, you would like to adjust the throws to suit your tastes, that is fine. The Cessna 182 has large elevators and does not require much throw. Too much throw can force the plane into a stall, so remember... “More is not better.”

## Balance your model

**NOTE:** This section is **VERY** important and must **NOT** be omitted! A model that is not properly balanced will be unstable and possibly unflyable.

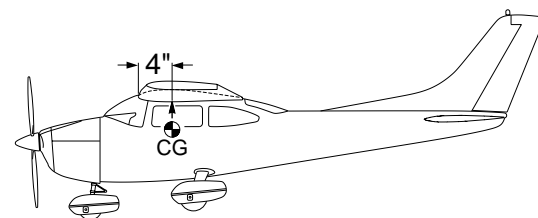

❑ 1. Accurately mark the balance point on the bottom of the wing on both sides of the fuselage. The balance point is shown on the plan (CG), and is located **4" (102 mm) back from the leading edge at the wing root** as shown in the sketch and on the plans. This is the balance point at which your model should be balanced for your first flights. Later, you may wish to experiment by shifting the balance up to **3/8" forward or 1/4" back** to change the flying characteristics. Moving the balance **forward** may improve the smoothness and tracking, but it may also require more speed for takeoff and make it more difficult

to slow down for landing. Moving the balance **aft** makes the model more agile, gives it a lighter “feel” and often improves landing. In any case, **please start at the location we recommend and do not at any time balance your model outside the recommended range.**

❑ 2. With the wing attached to the fuselage, all parts of the model installed (ready to fly) and an **empty** fuel tank, support the model at the balance point.

❑ 3. Lift the model at the balance point. If the tail drops when you lift, the model is “tail heavy” and you must add weight\* to the nose to balance. If the nose drops, it is “nose heavy” and you must add weight\* to the tail to balance. **NOTE:** Nose weight may be easily installed by using a spinner weight or gluing lead weights into the engine compartment. Tail weight may be added by using Great Planes (GPMQ4485) “stick-on” lead weights and, later, if the balance proves to be OK you can open the fuse bottom and glue these in permanently.

\*If possible, attempt to balance the model by changing the position of the receiver battery and receiver first. If you are unable to obtain good balance by doing so, **then** it will be necessary to add weight to the nose or tail to achieve the proper balance point.

## PRE-FLIGHT

### *Charge the batteries*

Follow the battery charging procedures in your radio instruction manual. You should **always** charge your transmitter and receiver batteries the night before you go flying and at other times as recommended by the radio manufacturer.

### *Find a safe place to fly*

The best place to fly your R/C model is an AMA (Academy of Model Aeronautics) chartered club field. Ask your hobby shop dealer if there is such a club in your area and join. Club fields are set up for R/C flying and that makes your outing safer and more enjoyable. The AMA also can tell you the name of a club in your area. We recommend that you join AMA and a local club so you can have a safe place to fly and have insurance to cover you in case of a flying accident. (The AMA address is listed on page 3 of this instruction book).

If a club and flying site are not available, you’ll need to find a large, grassy area at least 6 miles away from buildings, streets and other R/C activities. A schoolyard may look inviting but it is too close to people, power lines and possible radio interference.

### *Ground check the model*

If you are not thoroughly familiar with the operation of R/C models, ask an experienced modeler to check your radio installation and control surface set-up. Engine operation must also be checked and the engine “broken-in” on the ground by running at least two tanks of fuel through the engine. **Follow the engine manufacturer’s recommendations for break-in.** Check to make sure all screws remain tight, that the hinges are secure, and that the prop is on tight.

### *Range check your radio*

Make it a habit: Check the operation of your radio **before** you fly, **every time** you fly. With the transmitter antenna collapsed and the receiver

and transmitter on, you should be able to walk at least 100 feet away from the model and still have control. Have someone help you. Have them stand by your model and, while you work the controls, tell you what the various control surfaces are doing.

Repeat this test **with the engine running** at various speeds test with an assistant holding the model, using hand signals to show you what is happening. If the control surfaces are not always acting correctly, **do not fly!** Find and correct the problem first.

### *Engine safety precautions*

**NOTE: Failure to follow these safety precautions may result in severe injury to yourself and others.**

Keep all engine fuel in a safe place, away from high heat, sparks or flames, as fuel is very flammable. Do not smoke near the engine or fuel; and remember that the engine exhaust gives off a great deal of deadly carbon monoxide. Therefore, **do not run the engine in a closed room or garage.**

Get help from an experienced pilot when learning to operate engines.

Use safety glasses when starting or running engines.

Do not run the engine in an area of loose gravel or sand; as the propeller may throw such material in your face or eyes.

Keep your face and body, as well as all spectators, away from the plane of rotation of the propeller as you start and run the engine.

Keep items such as these away from the prop: loose clothing, shirt sleeves, ties, scarfs, long hair or loose objects (pencils, screwdrivers) that may fall out of shirt or jacket pockets into the prop.

Use a “chicken stick” device or electric starter; follow instructions supplied with the starter or stick. Make certain the glow plug clip or connector is secure so that it will not pop off or fall into the running propeller.

Make all engine adjustments from **behind** the rotating propeller.

The engine gets hot! Do not touch it during or directly after operation. Make sure fuel lines are in good condition so fuel will not leak onto a hot engine, causing a fire.

To stop the engine, cut off the fuel supply by closing off the fuel line or follow the engine manufacturer’s recommendations. Do not use hands, fingers, or any body part to try to stop the engine. Do not throw anything into the prop of a running engine.

## AMA SAFETY CODE

Read and abide by the following Academy of Model Aeronautics Official Safety Code:

### *General*

1. I will not fly my model aircraft in sanctioned events, air shows, or model flying demonstrations until it has been proven to be airworthy by having been previously successfully flight tested.
2. I will not fly my model aircraft higher than approximately 400 feet within 3 miles of an airport without notifying the airport operator. I will give right of way to, and avoid flying in the proximity of full-scale aircraft. Where necessary, an observer shall be used to supervise flying to avoid having models fly in the proximity of full- scale aircraft.
3. Where established, I will abide by the safety rules for the flying site I use and I will not willfully

and deliberately fly my models in a careless, reckless and/or dangerous manner.

7. I will not fly my model unless it is identified with my name and address or AMA number, on or in the model.
9. I will not operate models with pyrotechnics (any device that explodes, burns, or propels a projectile of any kind).

### *Radio control*

1. I will have completed a successful radio equipment ground check before the first flight of a new or repaired model.
2. I will not fly my model aircraft in the presence of spectators until I become a qualified flier, unless assisted by an experienced helper.
3. I will perform my initial turn after takeoff away from the pit or spectator areas, and I will not thereafter fly over pit or spectator areas, unless beyond my control.
4. I will operate my model using only radio control frequencies currently allowed by the Federal Communications Commission...

## FLYING



The Top Flite Cessna 182 Skylane is a great-flying, sport-scale airplane that flies smoothly and predictably, yet is highly maneuverable. Compared

to other scale models, its flight characteristics are quite docile and forgiving. It does not, however, have the self-recovery characteristics of a primary R/C trainer; therefore, you must either have mastered the basics of R/C flying or obtained the assistance of a competent R/C pilot to help you until you are able to safely and competently pilot the model yourself.

### *Balance the propeller*

Balance your propellers carefully before flying. An unbalanced prop is the single most significant cause of damaging vibration. Not only will engine mounting screws and bolts vibrate out, possibly with disastrous effect, but vibration will also damage your radio receiver and battery. Vibration will cause your fuel to foam, which will, in turn, cause your engine to run rough or quit.

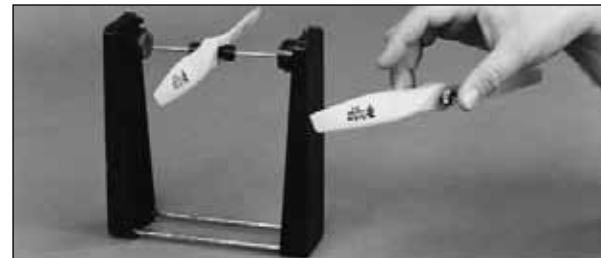

We use a Top Flite Precision Magnetic Prop Balancer (TOPQ5700) in the workshop and keep a Great Planes Fingertip Balancer (GPMQ5000) in our flight box.

### *Fuel mixture adjustment*

A fully cowled engine will tend to run at a higher cylinder temperature than an un-cowled engine. For this reason the fuel mixture should be set to run the engine at about 200 rpm below peak (maximum) speed. By running the engine slightly rich you will help prevent dead stick landings caused by overheating.

## Takeoff

If you have dual rates on your transmitter, set the switches to "high rate" for takeoff, especially when taking off in a crosswind. Although this model has good low-speed characteristics, you should always build up as much speed as your runway will permit before lifting off, as this will give you a safety margin in case of a "flame-out." When you first advance the throttle the plane will usually turn left slightly. Correct by applying sufficient right rudder to hold it straight down the runway. When the plane has sufficient flying speed, lift off by smoothly applying up elevator (don't "jerk" it off into a steep climb!), and climb out gradually. Do not use flaps for your initial takeoff. After you have the feel of the Cessna, takeoffs may be made with the flaps set at 50%.

**1.20 4-STROKE NOTE:** If you have installed a 1.20 4-stroke engine, throttle management on takeoff and throughout the flight is highly recommended! Your first few flights should be made using slightly more than half throttle for takeoff. Apply power gradually until you become familiar with the Cessna's flight characteristics.

## Flying

We recommend that you take it easy with your Cessna for the first several flights, gradually "getting acquainted" with this realistic model as your engine gets fully broken-in. Add and practice one maneuver at a time, learning how she behaves in each. For ultra-smooth flying and normal maneuvers, we recommend using the "low rate" settings as listed on page 52. "High rate" elevator may be required for spins. Though

the full scale Cessna 182 is not rated for aerobatics, the Top Flite 182 is capable of some graceful aerobatic maneuvers. A beautiful barrel roll may be accomplished by advancing the throttle to full, then pulling the nose about 25 degrees above the horizon. Apply about 3/4 aileron in one direction, and let the 182 roll 360 degrees without touching any of the other controls. If the proper roll rate is established, the wings should come back to level with the plane in a 20 to 25 degree dive. Reduce power and gently raise the nose to level flight. Loops are easily accomplished, but you should reduce power as the plane goes over the top to reduce stresses and enhance realism.

**CAUTION (THIS APPLIES TO ALL R/C AIRPLANES):** If, while flying, you notice any unusual sounds, (such as a low-pitched "buzz") this may be an indication of control surface "flutter." Any time you detect flutter you must immediately cut the throttle and land the airplane because flutter can quickly destroy its components. Check all servo grommets for deterioration (this will indicate which surface fluttered), and make sure all pushrod linkages are slop-free. If it fluttered once, it probably will flutter again under similar circumstances unless you can eliminate the slop or flexing in the linkages. Here are some things which can result in flutter: Excessive hinge gap; Not mounting control horns solidly; Sloppy fit of clevis pin in horn; Elasticity present in flexible plastic pushrods; Side-play of pushrod in guide tube caused by tight bends; Sloppy fit of Z-bend in servo arm; Insufficient glue used when gluing in the elevator joiner wire or aileron torque rod; Excessive flexing of aileron, caused by using a too-soft balsa aileron; Excessive "play" or "backlash" in servo gears; and Insecure servo mounting.

## Landing

When it's time to land, fly a normal landing pattern and approach. The Cessna 182 may bleed off airspeed more rapidly than the sport planes you are used to. For this reason, be prepared to carry a little power during approach. For your first landings, plan to approach slightly faster than stall speed and flare a few inches off the runway onto the main wheels.

### FLAPS

Full flaps make the Skylane very steady in the landing pattern, but just carry a little extra power to make up for the extra drag. The extra drag of the flaps also allows you to make shorter, steeper approaches. Like the full scale 182, the Top Flite 182 needs to touch down with a nose high attitude to avoid whacking the nose gear and skipping back into the air. For this reason, landings with flaps require a deliberate flare with high rate elevator to raise the nose. Touch and go's and go-arounds can be accomplished with full flaps, just use the elevator to establish a shallow climb. It is preferred to have the flaps up or at "half" setting for takeoffs and climb-outs because the plane will accelerate and climb much better.

**Have a ball! But always stay in control and fly in a safe manner.**

### GOOD LUCK AND GREAT FLYING!

If you enjoyed building the Top Flite Cessna 182 Skylane, try one of these outstanding .60 size Gold Edition kits as your next project.

**Top Flite AT-6 Texan** (TOPA0130)

69" Wingspan, 7.5 - 10 Lbs.

**Top Flite P-40E Warhawk** (TOPA0120)

64" Wingspan, 8 - 10.5 Lbs.

**Top Flite P-51D Mustang** (TOPA0110)

65" Wingspan, 8 - 10 Lbs.

**Top Flite F4U Corsair** (TOPA0100)

62" Wingspan, 7 - 9.5 Lbs.

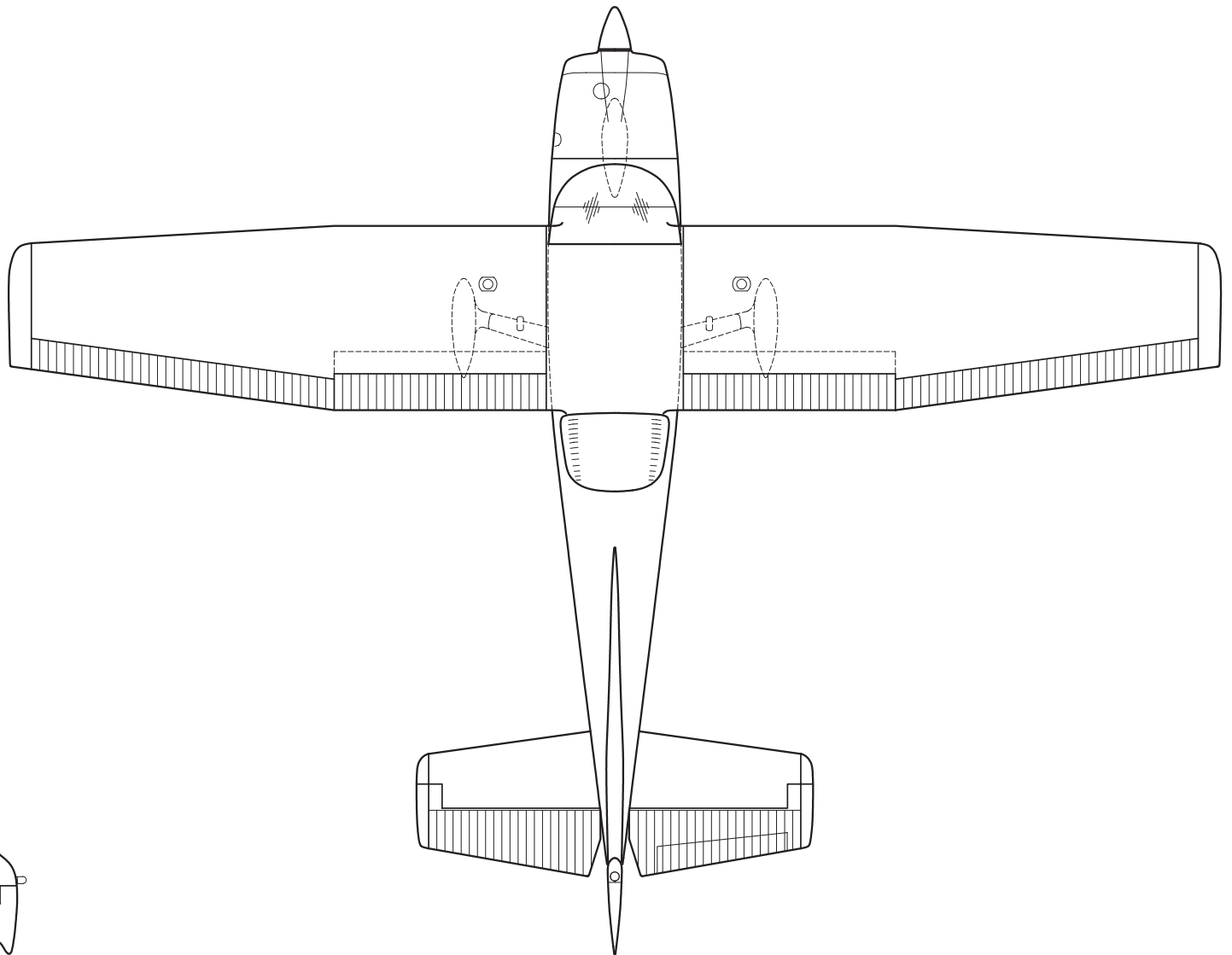
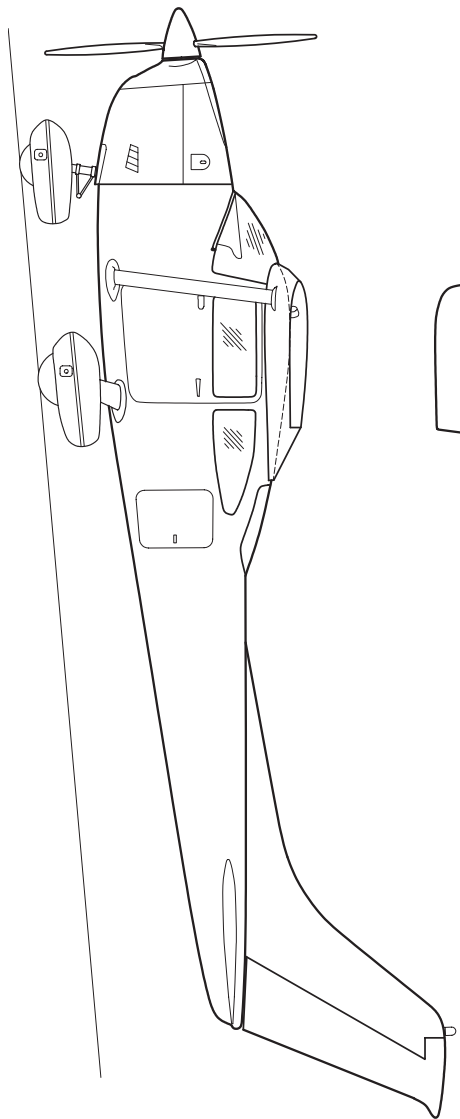

**2-VIEW DRAWING**

Use this layout for trim scheme planning only.  
Not suitable for scale documentation.

#### DETAILING HINTS



❑ 1. Carefully cut the **radios** and **fuel gauges** from the instrument decal included in your Top Flite Cessna kit and attach them to the **front** of the plastic instrument panel. Attach the remaining instrument decal pieces to scrap balsa or thin cardboard, then glue it to the **back** of the molded panel.



The numbers on this photo apply to the following steps

❑ 2. Carpet may be attached to the floor with 3M #77 spray adhesive. Glue the carpet in position, then cut around the front seat tracks to expose them. Trim the carpet edges to size.

❑ 3. Seat and door beading can be made from embroidery "floss" or string. Tack glue a short piece at one end with thin CA, then stretch it to the end of its run. Hold it with tweezers while you CA the floss or string in place.

❑ 4. Seatbelts are cut from 1/4" dressmakers' elastic (included in this kit). One end is threaded through the eye of a large T-pin and spot glued to itself. The pin is inserted through the floor, bent 90 degrees and glued to the underside of the floor. The buckles are cut from chrome trim tape or could be made from aluminum foil.

❑ 5. Maps and magazines are made from small pieces of the real thing.



❑ 6. The cavity on the back side of the control yokes is filled with automotive body filler or epoxy. Before the filler sets-up, insert a 1/8" x 1-1/4" dowel into the center of the yoke. Secure it in position until the filler cures. The dowels are mounted by drilling 1/8" holes through the instrument panel and glued to small scrap wood blocks on the back side.

❑ 7. All knobs and buttons are made from large and small quilters pins. Insert them through the instrument panel, then bend them 90° on the back side. Cut off the excess close to where the pins are bent, then glue them in position on the back side.

❑ 8. The pull straps on the doors are made from short pieces of scrap plastic glued in position with CA.

*Many more details can be added. It's up to you. A little imagination and craftsmanship is all it takes. Have fun with this project. The results will be well worth the effort.*

#### FINAL INSTALLATION

❑ 1. Glue the left and right cabin sides in position. We suggest using clear silicone sealer as the adhesive because it provides a good bond between wood and plastic.

❑ 2. Slide the floor into position between the sides followed by the aft bulkhead. The floor and aft bulkhead may be glued in position with CA. Glue the seats to the floor with CA **after** scraping off any paint from the points of contact.

❑ 3. Install the instrument panel using your chosen method.

**When you take your Cessna 182 to the field, try to be gracious in accepting all the praise you will undoubtedly get. Happy flying!**

PRINTED IN USA.

# Cessna 182 SKYLANE™



## SCALE INTERIOR KIT FOR THE GOLD EDITION CESSNA 182 SKYLANE



**WARRANTY.....** Top Flite Models guarantees this kit to be free from defects in both material and workmanship at the date of purchase. This warranty does not cover any component parts damaged by use or modification. In no case shall Top Flite's liability exceed the original cost of the purchased kit. Further, Top Flite reserves the right to change or modify this warranty without notice. In that Top Flite has no control over the final assembly or material used for final assembly, no liability shall be assumed nor accepted for any damage resulting from the use by the user of the final user-assembled product. By the act of using the user-assembled product, the user accepts all resulting liability.

If the buyers are not prepared to accept the liability associated with the use of this product, they are advised to return this kit immediately in new and unused condition to the place of purchase.



**Top Flite Models**  
P.O. Box 788  
Urbana, IL 61803  
Technical Assistance - Call (217) 398-8970

**READ THROUGH THIS INSTRUCTION BOOK FIRST. IT CONTAINS IMPORTANT INSTRUCTIONS CONCERNING THE ASSEMBLY OF THIS MODEL.**

Congratulations for deciding to install a fully detailed, scale looking interior in your Top Flite Cessna 182 Skylane. This is a project that can be as detailed or as straightforward as you care to make it – the choice is yours. We have provided the basic kit that can be assembled and painted in a few hours. It represents a stock Cessna interior as delivered from the factory. The color scheme and minor surface details change from plane to plane, so you may need to add extra goodies like headrests or shoulder harnesses depending on the full-scale plane you modeled. By using this kit, some imagination and your modeling experience, you can create a great looking interior that will "wow" them at the flying field.

#### TOOLS AND SUPPLIES:

- ❑ Thin CA – (Top Flite® Supreme™ recommended)
- ❑ Hobby knife and # 11 blades
- ❑ Scissors or Lexan® shears
- ❑ Round file
- ❑ 100, 220,340 and 400-grit wet or dry sandpaper

- ❑ Sanding block - (Great Planes Easy-Touch™ Bar Sander recommended – #GPMR6170)
- ❑ Selection of small paint brushes
- ❑ Paint compatible with styrene plastic
- ❑ Model Enamel paint – (Testors Enamel Recommended)
- ❑ Plastic model seam putty (Testors), or automotive body filler (Bondo®)

- ❑ Needle nose pliers
- ❑ Spray adhesive – 3M #77 (MMMR2000)
- ❑ Tweezers
- ❑ Silicone sealer adhesive

CESCP01 5/01 V1.1

Entire Contents © Copyright 2001

### SCRAPS FROM AROUND YOUR WORKSHOP

- Stiff paper or index card – for seat pockets
- Chrome trim tape – for seatbelt buckles
- Large T-pins – for seatbelt attachment

### GETTING STARTED

Assembling and installing your scale cockpit will probably require minor adjustments and "tweaking" to fit your particular model. This is because of variations in building technique, parts alignment and glue fillets that may interfere with proper positioning of the parts. A little patience is all that is required to obtain a good looking installation. Trim parts a little at a time, checking the fit after each adjustment. Remember, you can always remove material, but it's hard to put it back.



1. Start by trimming all parts to the embossed "trim lines." Be sure to leave a 1/8" - 3/16" lip around the fuse side panels to provide a gluing surface for the floor and aft bulkhead. Use a hobby knife or scissors to "rough cut" the parts, then sand the parts with a sanding block to straighten the edges. You can evenly sand the edges by simply taping a sheet of 240-grit sandpaper to your workbench. Then work the part in a circular motion while pressing down gently. Cut out the center of each instrument cavity and smooth the edges with sandpaper. **NOTE:** Save all scraps of smooth plastic (especially from inside the window openings) for later use.

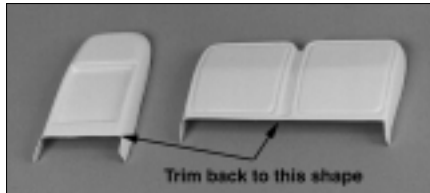

2. Carefully remove the bottom portions of the front and rear seat backs as shown in the photo. The side "tabs" will be used to attach the seat backs to the lower sections.

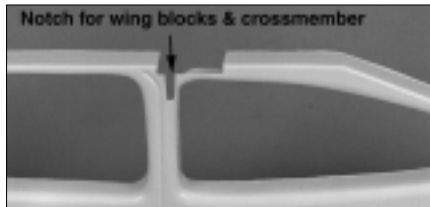

3. Refer to the exploded drawing on the following page to see how the parts will fit together. Without using glue, (and in the following order), fit the sides, floor, aft bulkhead and instrument

panel into the fuselage cavity. You will need to cut the top edge of the sides to fit around the wing blocks and top cabin cross-member as shown in the photo. Use the underside of the rear window frame and also the side windows for reference when trimming the side panels to size.

**NOTE:** We recommend that once the sides are in position, you glue three or four strips of 1/4" x 1/2" balsa across the width of the fuse at the bottom edge of the plastic side panels to provide additional support for the floor.

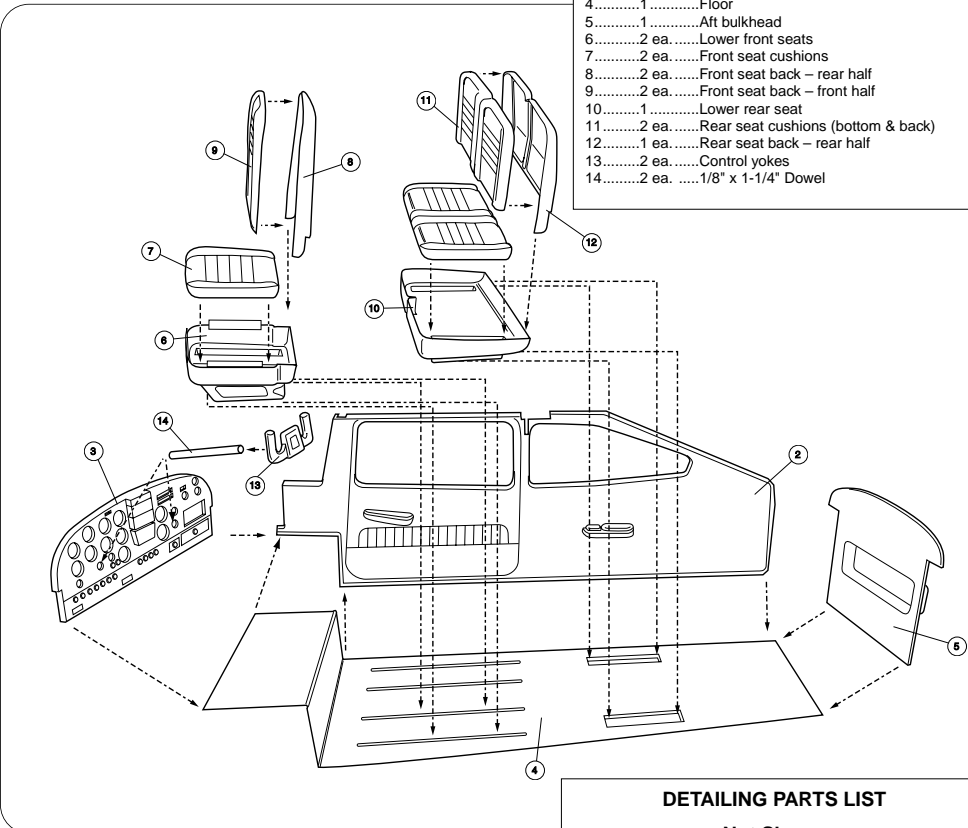

### PLASTIC PARTS LIST

- 1.....1 .....Side panel – left (Not Shown)
- 2.....1 .....Side panel – right
- 3.....1 .....Instrument panel
- 4.....1 .....Floor
- 5.....1 .....Aft bulkhead
- 6.....2 ea.....Lower front seats
- 7.....2 ea.....Front seat cushions
- 8.....2 ea.....Front seat back – rear half
- 9.....2 ea.....Front seat back – front half
- 10.....1 .....Lower rear seat
- 11.....2 ea.....Rear seat cushions (bottom & back)
- 12.....1 ea.....Rear seat back – rear half
- 13.....2 ea.....Control yokes
- 14.....2 ea.....1/8" x 1-1/4" Dowel

### DETAILING PARTS LIST

– Not Shown –

- 1 yd. ....Dressmakers' elastic – Seat belts
- 12 ea. ....Small head pins – Dash knobs and buttons
- 4 ea. ....Large head pins – Throttle/Mixture knobs
- 1 ea. ....9" x 18" Carpeting

4. Decide how you are going to attach the forward floor section (the part that covers the servos and battery compartment) and the instrument panel. Some strategically positioned spots of Velcro® Hook and Loop Material (Great Planes #GPMQ4480 recommended) may be used for this purpose or you could use #2 sheet metal screws and small mounting blocks made from scrap plywood or hard balsa. The servo cover could be folded back for access to the servos or it could be made completely removable – your option.

5. When you are satisfied with the fit of the primary cabin parts, remove them from the model and set them aside until it's time to paint.

### ASSEMBLE THE SEATS

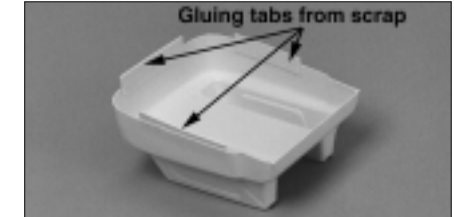

1. Cut several 1/4" x 1" strips of plastic from the flat scrap material you saved earlier. These will be used to create gluing tabs for the seats. Glue three strips inside the **bottom halves** of both **front seats** (protruding half way over the edge) as shown. Glue four strips inside the **bottom of the rear seat**.

2. Glue two or three strips to the inside of the three seat back cushions.

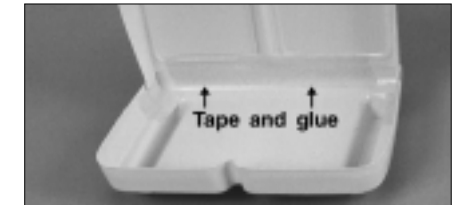

3. Insert the tabs of the rear seat back into the bottom half of the seat, then apply a piece of masking tape to the joint. The seat back should angle toward the rear of the cabin by a few degrees. Glue the seat back in position by "wicking" a few drops of thin CA into the joint from the back side. Remove the tape after the CA has cured.

4. Tape the rear seat cushions to the bottom half of the seat at a couple of places. When the two halves are aligned, use thin CA to glue the parts together. Use the same technique to add the seat back cushions.

5. Assemble the two front seats the same way as the rear seat.

6. Use plastic model seam putty or automotive body filler to cover all of the joints. When the filler has cured, wet sand it smooth with 340 or 400-grit sandpaper.

7. Seat back pockets can be made from index cards or stiff paper glued into position with thin CA.

### PAINTING AND DETAILING

1. Before painting, **thoroughly clean** the parts with rubbing alcohol, then allow them to dry completely.

2. Paint the parts with paint compatible with styrene. For the best results, use spray paint. Do not use Top Flite LustreKote™ as it is not compatible with styrene. If adding "carpeting," paint only the embossed seat tracks before installing the fabric.

# Cessna 182<sup>®</sup>

## SKYLANE™



## INSTRUCTION MANUAL ADDENDUM

The holes in the main landing gear for the 8-32 x 1-1/2" axle bolt and the #2 x 3/8" sheet metal screw may be sized incorrectly. If necessary, wearing a glove on the hand holding the gear, enlarge the hole for the axle with an 11/64" (or 3/16") drill. If the hole for the #2 sheet metal screw is too large, a #4 x 3/8" screw should be substituted.

**OPTIONAL:** If you wish to drill another hole in the gear for a second pant mounting screw, drill a 1/8" hole in the gear where shown for the second #4 x 3/8" screw.

