

MIDWEST AERO-SPORT™ .40

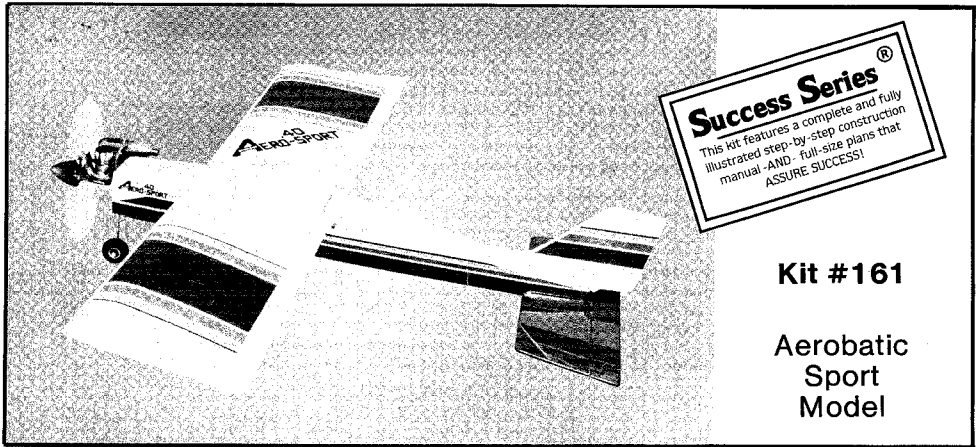

Kit #161

Aerobatic
Sport
Model

About This Construction Manual

In order to build this model **correctly**, you **must** follow these instructions in the order that they are presented.

Please read through this construction manual before starting assembly. It contains a complete list of everything necessary to build this kit, listed under "Materials You Will Need" and "Additional Components".

This manual also contains important warnings and cautions concerning the building and operation of your Aero-Sport .40.

Warning

The radio controlled model built from this kit is not a toy. R/C models are capable of causing serious bodily injury and property damage. **This product is sold with exclusion of all warranty expressed or implied, statutory or otherwise. Buyer assumes all risk of use.** It is your sole responsibility to build this kit correctly, to properly install all of the additional components and gear, and to test and fly the model in accordance with all safety standards as set down in the Academy of Model Aeronautics safety code. (See "The Aero-Sport .40", Page #2, for additional information on the Academy of Model Aeronautics).

MIDWEST
PRODUCTS CO., INC.

400 S. Indiana St., P.O. Box 564, Hobart, IN 46342



Before You Begin

The Aero-Sport .40

The classic lines of the Aero-Sport .40 can be traced back to the original **Das Ugly Stik**. Designed by Phil Kraft, it first appeared as a construction article in the radio control magazine, "Grid Leaks," in 1966. Since then, the structure of Ugly Stiks has been constantly improved by various modelers and kit manufacturers, including Midwest. Midwest has designed the Aero-Sport series of kits to make them the easiest to build, the strongest, and the best flying Stiks available in a kit. Besides adding reinforcement to the fuselage and a sheeted D-Spar wing for strength, wing dihedral and a swept fin and rudder have been added, which greatly improve the overall performance and handling of this classic sport model.

Although the Aero-Sport .40 is quite stable, it is a "Sport" model. Sport models are more maneuverable and faster than "Trainer Type" models. If you have any doubts about your ability to fly a sport model, we urge you to seek the help of an experienced, competent person to assist you with the initial flights. He should be able to check your model over to be certain that it is ready to fly and he should be able to take over if you loose control during the first flights. Joining an R/C model airplane club is the best way to find help. Consult your local hobby dealer for a list of the clubs in your area. We also recommend, and most clubs require, that you join the Academy of Model Aeronautics. AMA membership will provide some insurance coverage and will introduce you to a wealth of material that will help you to learn more about R/C models. The AMA can also provide you with a list of the clubs in your area.

Academy Of Model Aeronautics

1810 Samuel Morse Dr.
Reston, VA 22090
(703) 435-0750

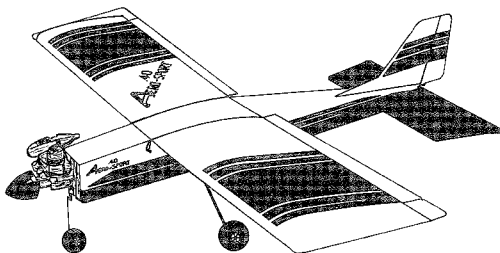

Customer Service

Should you experience a problem building this kit, we recommend you see your hobby dealer first. If you are unable to solve the problem, feel free to call, or write, our Customer Service Department.

If you find any missing or incorrectly made parts in this kit, contact our Customer Service Department.

Customer Service Department

Midwest Products Co., Inc.
P.O. Box 564
Hobart, IN 46342
(219) 942-1134

Table of Contents

	Page No.
I. Before You Begin	
The Aero-Sport .20	2
Customer Service	2
II. Getting Started	
Materials You Will Need	4 - 5
Additional Components	5
III. Construction Tips	
How to Read the Plan	6
Cutting	7
Using Adhesives	7
IV. Assembly Instructions	
Wings	
Wing Panels	9 - 16
Joining the Wing Panels	16 - 18
Ailerons	18 - 21
Tail Section	
Stabilizer & Elevator	21 - 23
Fin and Rudder	23 - 24
Fuselage	
Fuselage Assembly	25 - 34
Radio Installation	
Fuselage	35 - 36
Wing	37 - 38
Final Assembly	
Fuel Tank	38 - 39
Fuselage Sheeting	39 - 41
Wing Incidence	41 - 43
Landing Gear	43 - 45
Finishing	46
Equipment Installation and Set Up	
Fuel Tank Installation	46
Wing Dowels	47
Receiver and Battery	47
Weight and Balance	48
Control Throws	48
Flying	48
V. Product Evaluation Card	49

Acknowledgements

The following people developed and produced this construction manual.

Written By: Don Sobbe Illustrations By: Don Hardy Typesetting and Layout By: Denise Taylor

Getting Started

Materials You Will Need

You will need the following items to build this kit. Most of them are available from your local hobby dealer.

Fast Drying Cyanoacrylate Adhesive -

Used to bond balsa wood to balsa and some hardwood parts. Use where an instruction tells you to glue, or bond parts with "CA".

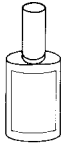

Slow Drying Cyanoacrylate Adhesive -

Used to bond balsa and hardwood joints. Use where an instruction tells you to glue or bond parts with "Slow CA".

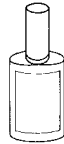

Note: Cyanoacrylate adhesives are manufactured in many different formulations, some of which do not work well on models. Consult your local hobby dealer for the proper adhesive brands. (See "Using Adhesives", Page #7).

Warning: Cyanoacrylate adhesives cure very rapidly. Read all warnings and safety instructions on these adhesives.

Accelerator -

Used to speed up the drying time of cyanoacrylate adhesives.

Note: Be sure that the accelerator you buy is the same brand, or compatible with, the brand of CA and Slow CA you will be using.



Quarter-Inch Electric Drill, and a variety of Drill Bits -
to include 1/16", 3/32", 1/8", 5/32" and 1/4".

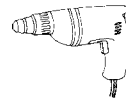

#80 and #220 Grit Aluminum Oxide Sandpaper -

Generally, the #80 grit sandpaper is used to rough sand and shape parts. The #220 grit is used to finish sand the model prior to covering.

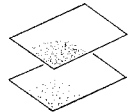

Slow Drying Epoxy -

Used to fuel-proof and bond parts and sub-assemblies where strength is critical.

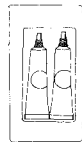

Sanding Block -

This is a wood or aluminum block with a flat side. It has grooves and a wedge to hold sandpaper to it and is used to sand and shape straight edges and surfaces.

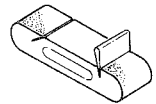

Note: #80 grit sandpaper should be used with the sanding block to build this model.

Rubbing Alcohol -

Used as a solvent to remove excess epoxy from parts and fingers.

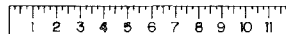

12" and 36" Steel or Aluminum Straight Edges -
Used to measure and align parts and assemblies.

Pencil -

Used to mark part locations.



Note: Do not use a ball point pen or marking pen to draw or write on parts. The ink in these instruments will bleed through most finishing materials and cause a smudge.



X-Acto Knife and Extra #11 Blades -

This is a hobby knife with a small diameter metal handle and chuck for holding the blades. The #11 blades are a general purpose size that will cut and trim all of the wood parts in this kit. (see "Cutting" Page #7).

- 4 Feet of Strong String** -
Used to build pushrods. Carpet thread is ideal.



- Needle-Nose Pliers (With Cutting Jaws)** -
Used to bend, shape and cut small diameter wire.



- Pliers**

- T-Pins** -
Used to hold parts together while gluing.
You will need at least 12 t-pins.



- Plastic Wrap or Waxed Paper** -
Used to cover the plan and building board so that parts are not accidentally bonded to them.

- Assorted Screwdrivers**



- Flat File**



- Scissors**



- Masking Tape** -
Used to hold parts together while gluing.



- Small Square** -
Used to align parts at right angles.

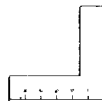

- Building Board** -
This can be any flat, stiff material that will accept and hold t-pins. You will need a building board that is at least 14" x 48". A soft pine or cork bulletin board will work well.



Note: It is very important that the building board be flat. The wings will be built on this board. If it is twisted or bowed, the wings will assume this shape and the model will not fly properly.

- Assorted Screwdrivers**

- Finishing Materials** -

Although the model can be painted, we recommend that you finish it with Super Monokote. This is an iron-on covering that has a high gloss, fuel-proof finish. If damaged, it can be repaired quickly and easily. You will need 2 six-foot rolls of Super Monokote to cover your Aero-Sport .20, not including trim colors. (See "Finishing" Page #46.)

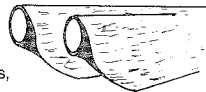

Note: If you decide to finish your Aero-Sport .20 with Monokote, you will also need a Monokote iron and heat gun.

There are other finishing materials available. Your hobby dealer will be glad to explain their application.

Additional Components

The following list of parts and components are required to complete this model and make it ready to fly. Because of variety, availability and personal preference, these items are left for the builder to select. All of these items are shown on the plan. Specific brands illustrate installation only and are not necessarily recommendations for these products.

- 1 - 4 Channel Radio
- 1 - .30 to .45 C.I. 2-Cycle or 1 - .45 - .61 C.I. 4-Cycle Engine with Muffler and Prop
- 1 - 8 oz. Fuel Tank
- 24' - Silicon Fuel Line
- 1 - 2-1/4" Wheel
- 2 - 2-3/4" Wheels
- 6 - 5/32" Wheel Collars
- 13 - Hinges
- 1 - Flexible Throttle Cable with Connectors
- 6 - Pushrod Connectors
- 1 - Box #64 Rubber Bands
- 2 - 1/2" x 6" x 12" Sheets of Foam Rubber

Construction Tips

How To Read The Plan

If the symbols and lines on the plan are unfamiliar to you. This section will explain what the plan is and how to use it.

The plan is a full-size drawing of the model that shows the correct size, shape and relationship of all of the parts. In order to show all of the parts "together", the plan is drawn using cutaway views, dashed lines and sections that allow you to "see through" some, or all, of the parts.

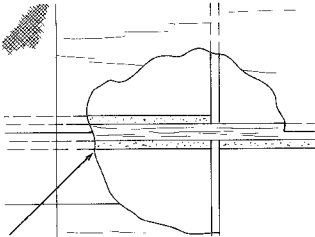

Cutaway views appear as if a portion of a part, or parts, were cut out. This is done to clearly show the parts immediately behind the cutaway part. The actual part is not to be cut this way.

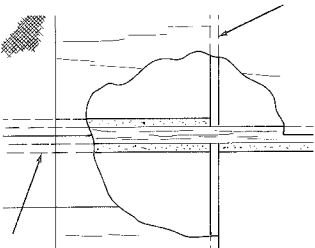

Dashed lines indicate a parts, or a portion of a part, that is underneath or inside of another part.

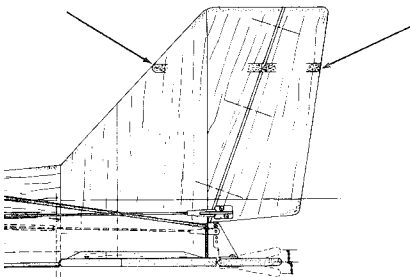

Parts that have shapes not apparent in one view are shown by sections.

The plan will be used in several ways. It will be helpful in identifying and positioning parts on other parts that are not built directly on the plan. Assemblies, such as the wings, will be built on the plan using the drawings as a pattern to locate parts. And, the plan will be useful in positioning components, such as the radio, before installation in the model.

Cutting

Note: Most of the parts in this kit are pre-cut to size. **Do not** cut or shape parts unless the instructions tell you to do so.

When cutting parts with your knife, make the first cut at light pressure, being careful that the point of the knife goes exactly where you want it. Subsequent cuts should be made at moderate pressure until the part is cut out. Use a steel straight edge to guide the blade when cutting straight lines.

If, during construction, you notice the knife blade starting to **tear** the wood as you cut, the blade is dull. Replace it with a new blade. A sharp blade will make cutting easier and will enable you to work more accurately.

If you are going to finish your model with one of the iron-on covering materials, you will find that these materials will dull knife blades very quickly, and it will be necessary to replace the blade often. Typically, you can expect to use four to six blades to cut and trim iron-on finishing materials for a model of this size.

Using Adhesives

Although water-based white glues can be used to assemble this kit, it has been designed to be built using cyanoacrylate adhesives, CA and Slow CA. These adhesives dry very rapidly. This will save you a lot of time and work by eliminating the need to pin, or tape, many parts together during assembly.

There are several different brands of CA adhesives available from your hobby dealer that have been formulated specifically for use in model construction. Among these are Zap, Hot Stuff and Jet. These are all fine products and any of them will do the job.

The following general uses apply to all CA adhesives. However, there are slight differences in the way each brand is used. Read and follow the specific instructions for the brand you are going to use. Also, read and follow all warnings and cautions on these products. **If used improperly, they can be dangerous.**

When using CA adhesives, place the parts to be bonded into contact and then run the CA into the joint. In order for these adhesives to bond, there should not be any gaps in the joint between the parts. The bond will be instantaneous, so be certain that the parts are positioned exactly as you want them.

Slow CA is a thick form of CA. It has the ability to bridge small gaps between parts. It also cures at a slower rate. Generally, it is to be used where parts must be moved around during gluing, where parts are too large to be held in the desired position, or where the gluing surface is too large to apply CA to the joint. In use, slow CA is applied to one of the parts, and then the parts are joined.

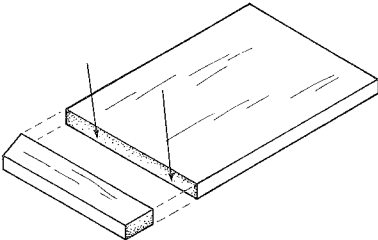

Note: Some brands of slow CA will soak into the end-grain of wood parts, resulting in a weak joint. To prevent this, apply Slow CA to the end grain of the part and allow it to cure. This will seal the end grain. Apply a second coat of Slow CA to the part and then join the two parts. This is called "pre-gluing". Test the Slow CA that you will use on some scrap wood to see if pre-gluing is necessary for that brand.

Most CA manufacturers have a product available that is known by the generic name, "Debonder". This is a solution that will dissolve CA and Slow CA adhesives. It is very useful for separating parts that are not constructed properly, and for removing CA adhesives that come into contact with your skin and tools. Although debonder isn't necessary to build this model, you may want to have it available during construction.

Assembly Instructions

In order to build this model **correctly**, you **must** follow these instructions in the order that they are presented.

This manual divides construction of Aero-Sport .20 into sections - Wing, Fuselage, etc. Within each section, construction is further broken down into sub-assemblies; Stabilizer and Elevator, Fin and Rudder, etc. Where necessary, general instructions and comments appear at the start of each sub-assembly. Explanations that clarify individual instructions appear as "Notes" following the instruction.

There is a description of the parts to be used in each sub-assembly at the start of that sub-assembly. Read each section carefully and identify all of the parts used in each sub-assembly before starting construction.

Most of the wood parts for each sub-assembly are packed in numbered plastic bags. In some bags, not all of the parts will be used at once. Parts not used should be put back in the proper bag. They will be used later in construction.

Most hardware items are packed in one plastic bag. Various parts from this bag will be used at different points in construction. To avoid losing these small parts and screws, they should be kept in this bag until needed.

If you find any missing or incorrectly made parts in this kit, contact our Customer Service department. (See "Customer Service" Page #2.)

Check-off boxes () appear next to each instruction throughout the text to help you keep track of your progress. Dual check-off boxes () appear next to instructions that are to be repeated.

Some of the sections in this manual do not have check-off boxes. These sections explain **general** procedures, rather than specific instructions.

The illustrations in this manual are not necessarily proportionally correct. Their purpose is to augment the written instructions and also to clarify and detail many of the assemblies shown on the plan. The manual and plan should be used together during construction.

Follow the instructions in this manual carefully. Install and operate the engine, radio and all accessories as per the manufacturer's instructions.

Build each sub-assembly accurately, according to the plan and instructions. Be sure that all of the parts are aligned correctly and that you use the proper adhesive for each assembly. The instructions will tell you which adhesive to use for each assembly.

The importance of building this model accurately, correctly and properly, cannot be over-stressed. A model that has not been built straight, correctly aligned and balanced, will not fly properly and will be difficult to control. Remember, you are only going to build the model once. Hopefully, you will fly it for a long time. So, using a little extra care in construction will pay off in a model that gives you many hours of enjoyable, trouble-free flying.

Wings

The wings are built as two separate panels on a simple 3/16" square basswood jig. It will be necessary to turn the panels over during construction. This method will allow you to build the wings quickly and correct any misalignment before completion. The construction sequence must be followed in order to properly join the wing panels. Note that the plan shows the top view of each wing panel.

Parts are provided in the kit which will allow you to build the wing with, or without, dihedral. As a practical matter, a flat wing, without dihedral, will improve the model's handling a little during inverted flight and rolling maneuvers. However, stability during take-offs and landings will not be as good as the same wing with dihedral. With dihedral, turns can be made using the rudder or the ailerons and, if you wish, the model can be flown using three channels. The flat wing, without dihedral, requires the use of ailerons to perform banked turns. You must decide which way you want to build the wing before installing the root rib in each wing panel.

Wing Panels

You will need the parts illustrated below to complete this sub-assembly. The ribs, wing tips, and center section sheathing are in Bag Number One (#1). The basswood jig, spars, leading and trailing edges and the cap strips are in Bag Number Two (#2). The leading and trailing edge sheathing is in Bag Number Three (#3). The shear webs are in Bag Number Four (#4). The wing tip stiffeners are in Bag Number Five (#5). The dihedral gauge is in Bag Number Six (#6).

Note: The illustrations below list the number of parts needed to build **one** wing panel. The parts bags contain parts for **both** wing panels.

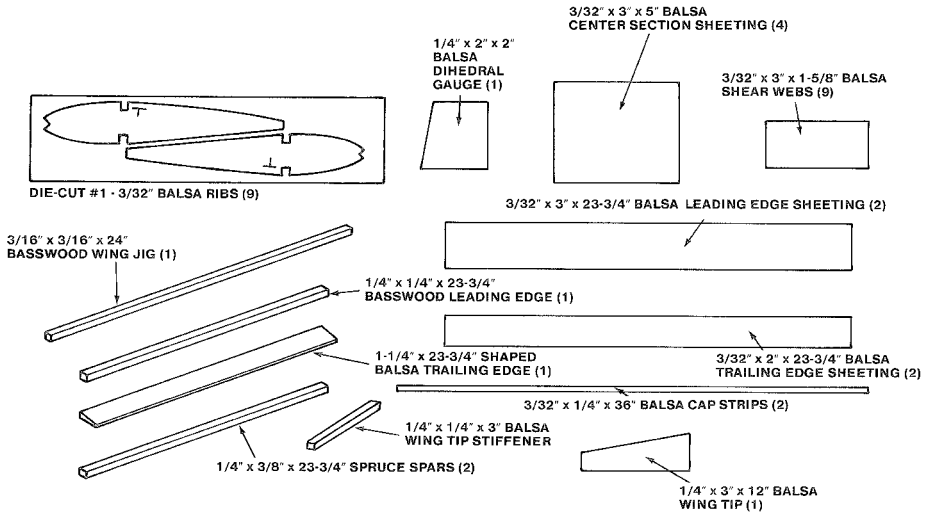

1. Stand a 36" straight edge, on edge, against your building board, as shown. Move it around the board and note any high or low spots. Use thin shims, made from scrap wood and placed under the board, to correct any irregularities. Also, sight across the board at eye level. Look for any twists or bowing in the board. When you are finished, your building board should be flat.

Note: Both wing panels will be built on this board. If the board is twisted, or bowed, the wings will assume this shape. No amount of work later on will correct this error and, as a result, the model may not fly properly.

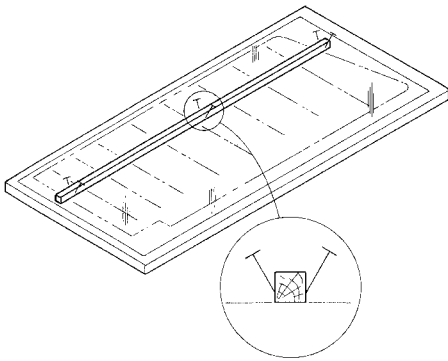

- □ 2. The plan is easier to work with if the wing drawings are cut from it, and then cut again, to provide separate right and left wing plans. Lay the **right** wing plan completely on the building board and cover it with plastic wrap.

Note: Lay the **left** wing plan on your building board if you are **repeating** this sub-assembly.

- □ 3. Align the 3/16" x 3/16" x 24" basswood wing jig over the drawing of the wing spar. The ends of the jig should extend beyond the ends of the spar. Then, pin the jig to the plan and building board, as shown.

Note: Place the pins between the rib locations shown on the plan.

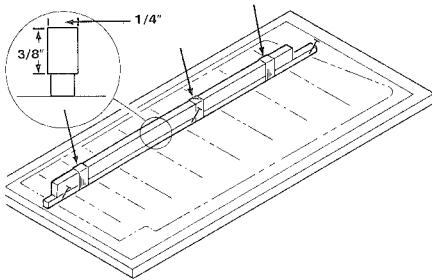

- □ 4. Spray accelerator on all four sides of one 1/4" x 3/8" x 23-3/4" spruce spar. Lay this spar on top of the 3/16" jig so that its 1/4" side is in contact with the jig, as shown. Be sure the ends of the spar are aligned with the drawing of the spar on the plan. Loosely secure the spar to the jig with masking tape placed between the rib locations, as shown.

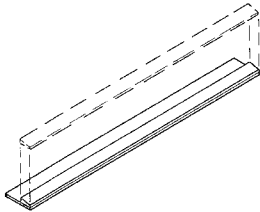

- □ 5. Apply Slow CA to one side of one 1-1/4" x 23-3/4" tapered trailing edge. Align the narrow edge, and ends, of the trailing edge with the edges of a 3/32" x 2" x 23-3/4" trailing edge sheet and press it into place, as shown.

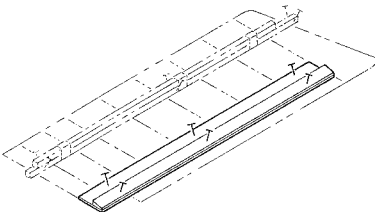

- □ 6. Align the assembled trailing edge over the drawing of the trailing edge on the plan. Pin it in position, flat on the plan, as shown.

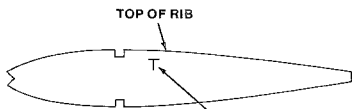

7. Remove nine (9) ribs from the die-cut sheets in Bag Number One (#1).

Note: The letter T is stamped on each rib to indicate the top side of each rib. The ribs are not symmetrical and must be positioned with the letter T facing up, as shown here.

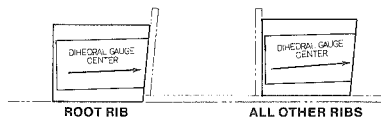

Note: Dihedral refers to an angle formed by the two wing panels. This angle gives the model stability.

The dihedral gauge will be used to help position the ribs. It is to be held against each rib, as shown. The root rib must be installed at an angle to allow for the wing's dihedral. The dihedral gauge will be used to establish this angle, as shown.

However, if you wish to build the wing **without dihedral**, use the dihedral gauge to install the root rib at the same angle as all of the other ribs.

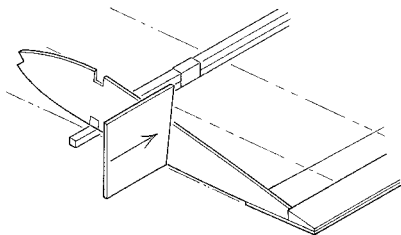

8. Position one rib over the drawing the root rib on the plan, and flush with the ends of the trailing edge sheet and spar. Using the dihedral gauge to hold this rib at the correct angle, glue the rib to the trailing edge, trailing edge sheeting and spar with CA.

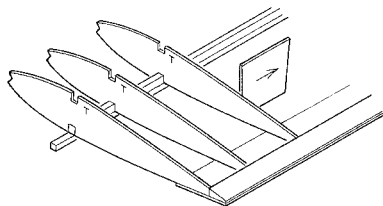

9. Using the dihedral gauge, align the remaining ribs over the drawings of the ribs on the plan and glue them to the trailing edge, trailing edge sheeting and spar with CA.

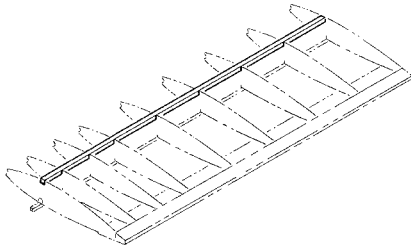

- □ 10. Spray accelerator on all sides of another $1/4" \times 3/8" \times 23\text{-}3/4"$ spruce spar. Press this spar into the notches in the tops of the ribs so that the top of the spar is flush with the tops of the ribs and one end of the spar is flush with the root rib.

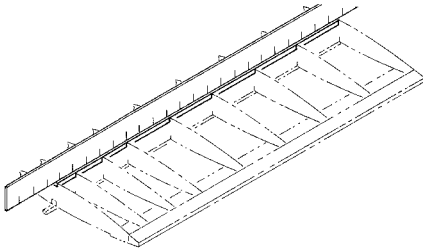

- □ 11. Stand a 36" straight edge on the spar, as shown, and adjust the spar so that it makes contact with the straight edge over its full length. Adjust the ribs so they are all square to the spars, and then glue the top spar to the ribs with CA.

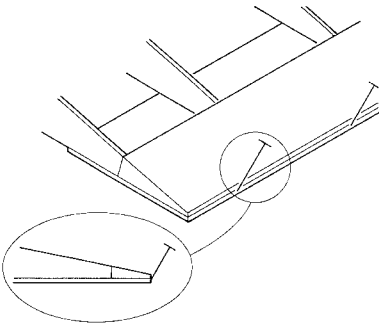

- □ 12. Insert T-pins through the trailing edge, as shown, to hold the trailing edge flat on the building board. Then, remove any pins from the trailing edge sheeting that are between the ribs.

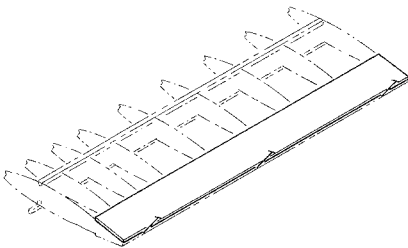

- □ 13. Apply Slow CA to the last $3/4"$ of each rib and to the trailing edge. Align a $3/32" \times 2" \times 23\text{-}3/4"$ balsa trailing edge sheet flush with the edge, and ends, of the trailing edge. Then, press it into contact with the trailing edge and ribs, as shown.

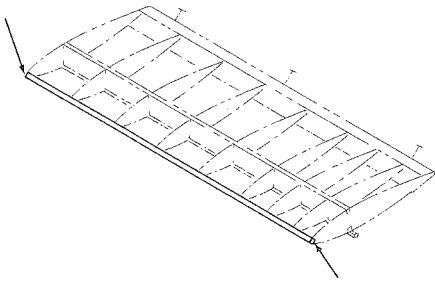

- 14. Apply Slow CA to the notch in the root and tip ribs **only**. Align the ends of one $\frac{1}{4}$ " x $\frac{1}{4}$ " x 23-3/4" basswood leading edge flush with the root and tip ribs and press it into place.
- 15. Press the leading edge into the notches in the remaining ribs. Glue it to these ribs with CA.

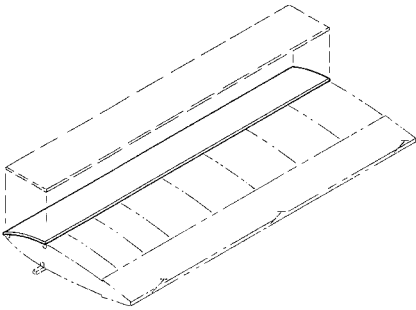

- 16. Apply Slow CA to the leading edge, ribs and the forward top edge of the spar. Position a $\frac{3}{32}$ " x 3" x 23-3/4" leading edge sheet on the spar so that it covers 1/2 of the spar, as shown on the plan. Align the ends of this sheet with the ends of the spar and press it into contact with the spar **only**. After the Slow CA **grabs**, lay your hands flat on the leading edge sheet and roll it into contact with the ribs and leading edge. Start at the center and work towards both ends. Hold the sheet in position until the Slow CA cures.

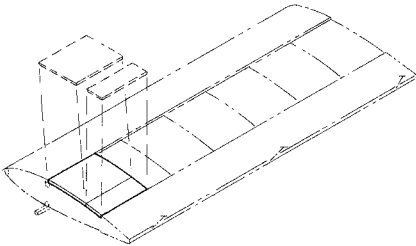

- 17. Fit and glue the two $\frac{3}{32}$ " x 3 x 5" balsa center section sheets in place with Slow CA.

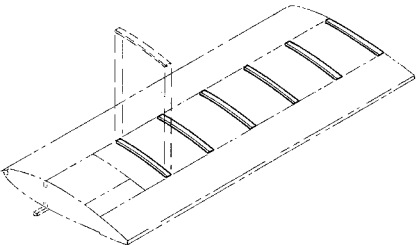

- 18. Cut the cap strips from the $\frac{3}{32}$ " x $\frac{1}{4}$ " x 36" balsa strips to fit between the leading and trailing edge sheeting. Apply CA to the ribs and spar. Position the cap strips on the ribs, as shown on the plan.

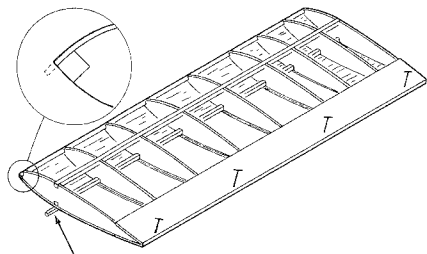

- □ 19. Remove the wing panel from the plan and use a sanding block to sand the leading edge sheet flush with the leading edge, as shown. Then, turn the wing panel over. Align the trailing edge with the drawing of the trailing edge on the plan. Pin the wing panel to the building board so that the leading edge sheet is on the bottom and the spar is over the jig, as shown.

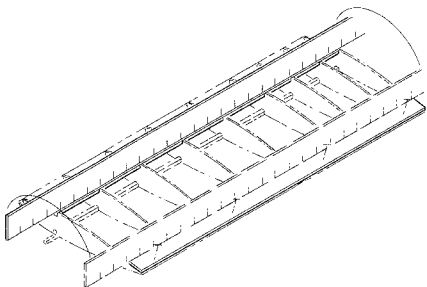

- □ 20. Stand a 36" straight edge along the trailing edge and then along the spar, making certain that they are flat and that there are no gaps between these parts and the straight edge.

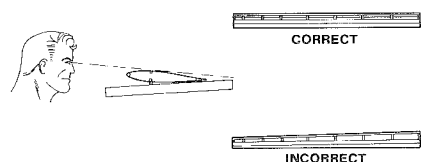

- □ 21. Sight across the spar and trailing edge, as shown, to be certain that they are parallel.
Note: Instructions #20 and #21 are important. If the spar or trailing edge is bowed, this shape will be locked in when the next leading and trailing edge sheets are installed. Adjust the pins, or your building board, as necessary to remove any bowing, or twists, in the wing panel.

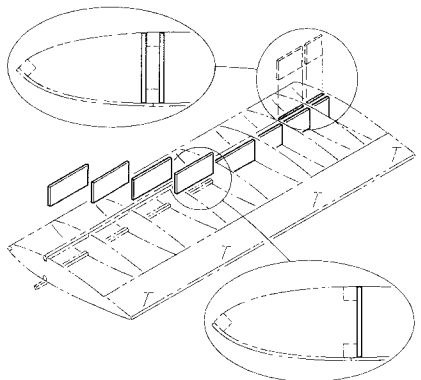

- □ 22. Use Slow CA to glue the pre-cut balsa shear webs to the **back** side of both spars, as shown here and on the plan. Also, glue shear webs to the **front** side of both spars between the first two ribs, as shown here and on the plan.
Note: Due to slight differences in construction techniques, it may be necessary to trim the shear webs to fit between the ribs. If a small gap results between the webs and ribs, it's ok. The important thing is to be sure that each shear web is bonded securely to **both** spars. These webs add a great deal of strength to the wing. **Do not** omit them.

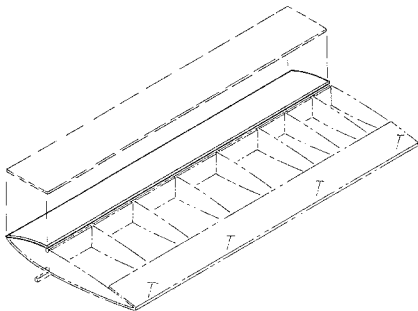

- □ 23. Apply Slow CA to the leading edge, ribs and the forward top edge of the spar. Position a $3/32" \times 3" \times 23-3/4"$ leading edge sheet on the spar so that it covers 1/2 of the spar, as shown on the plan. Align the ends of this sheet with the ends of the spar and press it into contact with the spar **only**. After the Slow CA **grabs**, lay your hands flat on the leading edge sheet and roll it into contact with the ribs and leading edge. Start at the center and work towards both ends, holding the sheet in position until the Slow CA cures.

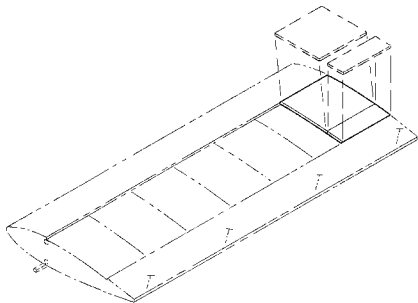

- □ 24. Fit and glue the two $3/32" \times 3" \times 5"$ balsa center section sheets in place with Slow CA.

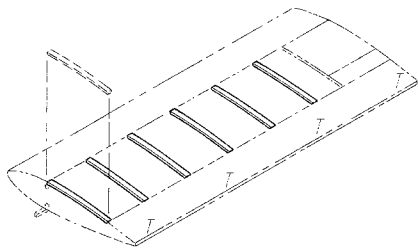

- □ 25. Cut the cap strips from the $3/32" \times 1/4" \times 36"$ balsa strips, to fit between the leading and trailing edge sheeting. Apply CA to the ribs and spar. Position the cap strips on the ribs, as shown on the plan.

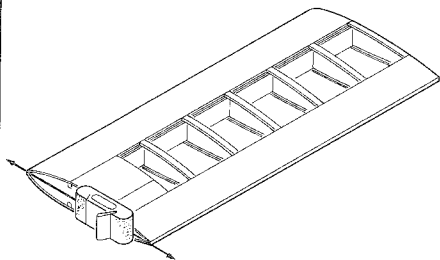

- □ 26. Remove the wing panel from the plan.
- □ 27. Use a sanding block to lightly sand all of the sheeting and spars flush with the tip and root ribs, as shown.

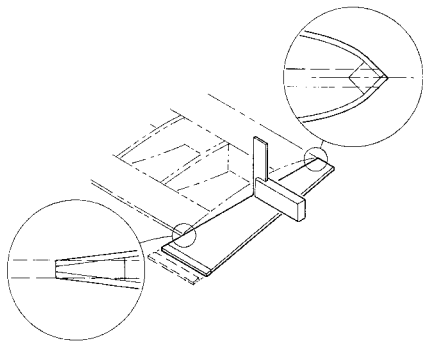

- □ 28. Apply Slow CA to the edge of one pre-cut 1/4" balsa wing tip. Position the wing tip on the tip rib so that it is centered on the leading and trailing edges, as shown. Use a small square to align the wing tip relative to the tip rib, as shown. Then, glue a wing tip stiffener to the trailing edge of the wing tip with Slow CA.

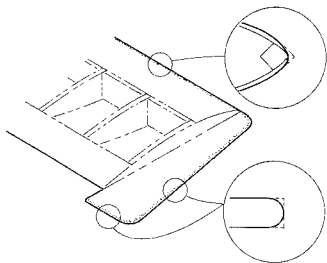

- □ 29. Use a sanding block to sand the leading edge and wing tip to a round section, as shown here and on the plan.
- □ 30. Repeat Instructions #1 thru #29 to build the left wing panel.

Joining The Wing Panels

You will need the parts illustrated below to complete this sub-assembly. The fiberglass cloth is packed in the hardware bag. Two dihedral braces are packed in Bag # 1. Select the dihedral brace for the wing you are building. The remaining brace will not be used.

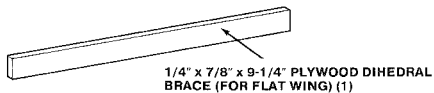
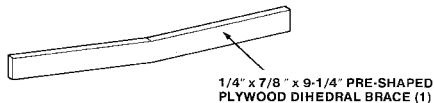

Note: The following illustrations show the wing being built **with** dihedral. The instructions are the **same** for wings being built **without** dihedral. Exceptions to this are explained in the instructions.

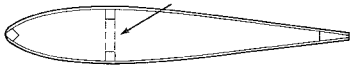

- 31. Use an X-acto knife to remove the portion of the root rib between the spars, as shown, on both wing panels.

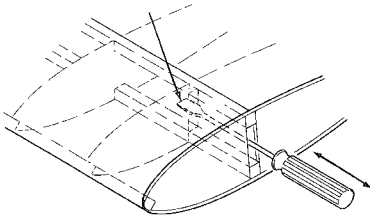

- 32. Use a screwdriver to punch out the portion of the second rib between the spars on both wing panels, as shown. Be sure the blade of the screwdriver is parallel to the wood grain of the rib to avoid damaging the webs.

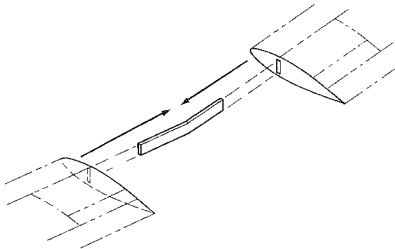

- 33. Insert the dihedral brace half way into the slot between the spars on one wing panel. Then, insert the other half of the dihedral brace into the slot in the opposite wing panel and butt the two panels together.

Note: If one half of the dihedral brace will not slip all the way into each slot, push the screwdriver into the slots again to remove any burrs, or wood scraps, that may be stopping the dihedral brace.

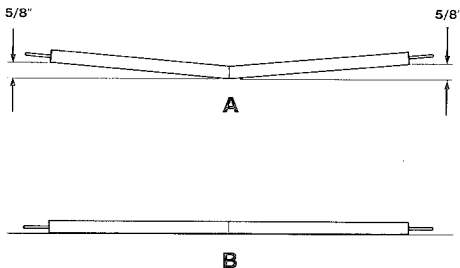

- 34. Lay the joined wing panels on a flat surface. If you are building the wing **with** dihedral, use scrap wood to prop up each wing tip 5/8", as shown in (A). If you are building the wing **without** dihedral, lay the joined wing panels flat on the surface, as shown in (B). If there are any gaps between the two wing panels, sand the root ribs to create a tight joint.
- 35. Separate the wing panels and remove the dihedral brace.

Note: Instructions #36 thru #38 are to be completed before the epoxy cures.

- 36. Mix about two (2) ounces of slow-drying epoxy, as per the manufacturer's directions. Use a stick, made from scrap wood, to push epoxy into the slots in both wing panels. Be sure the epoxy is smeared on all sides of the slots.

Apply epoxy to all sides of one-half of the dihedral brace and push that half into the slot in one wing panel. Then, apply a thin layer of epoxy to the root ribs and remaining half of the dihedral brace.

- 37. Join the wing panels. Remove any excess epoxy, with paper towels soaked in alcohol. Then, align the leading and trailing edges of the two panels and wrap the joint with masking tape on both sides, as shown.
- 38. Lay the wing on a flat surface and set the dihedral, as explained in Instruction #34. Allow the wing to remain in position until the epoxy cures. Then, remove the masking tape.

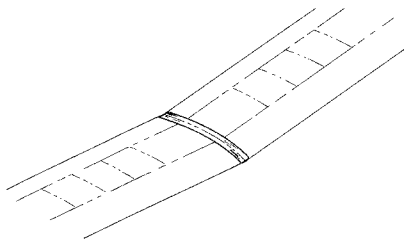

Caution: Perform Instructions #39 thru #41 in a well-ventilated area to avoid breathing any fumes from the CA or epoxy.

- 39. Center the fiberglass cloth on the upper trailing edge of the wing, as shown here and on the plan. Tack it in position with drops of CA. Then, gently pull the fiberglass cloth across the top of the wing and tack it to the leading edge with CA. Tack the sides of the cloth to the wing with CA. Then, cut the excess cloth off at the leading edge.
- 40. Run CA onto the cloth. Immediately rub the cloth down to the wood with a quick circular motion of your finger. Work a small area at a time until the entire piece of the fiberglass cloth is bonded to the wing.

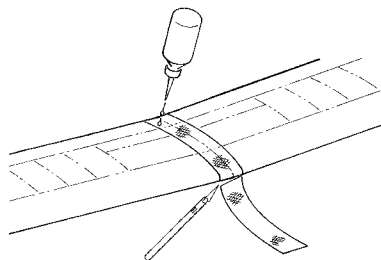

Note: If you do not wish to bond the fiberglass cloth to the wing with CA, mix about two (2) ounces of slow-curing epoxy and brush it over the fiberglass cloth with a stiff brush. Work the epoxy through the weave of the cloth so that it soaks into the wood.

- 41. Repeat Instructions #39 and #40 to fiberglass the underside of the wing center section.

Ailerons

You will need the parts illustrated below to complete this sub-assembly. The aileron torque rods and bearing blocks are in the hardware bag. The ailerons are in Bag Number Two (#2).



1/4" x 1-1/2" x 20-3/4" BALS AILERONS (2)

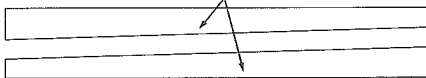

AILERON BEARING BLOCK (2)

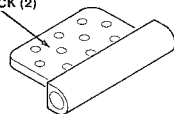

You will also need six (6) hinges, not supplied with the kit, to complete this sub-assembly.

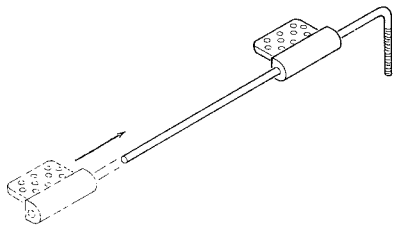

- 42. Slip one aileron bearing block onto each torque rod, as shown.

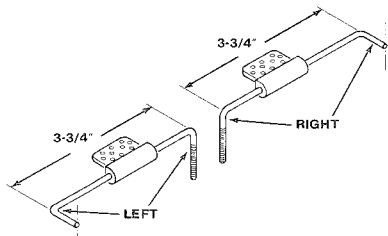

- 43. Use a pair of pliers to make a 90° bend, at a 90° angle, 3-3/4" from the existing bend in each torque rod, as shown. Study the illustration carefully to be certain that you make a **left** and a **right** torque rod, as shown. Then using the cutting jaws of your needle-nose pliers, cut the unthreaded ends of the torque rods to the length shown on the plan.

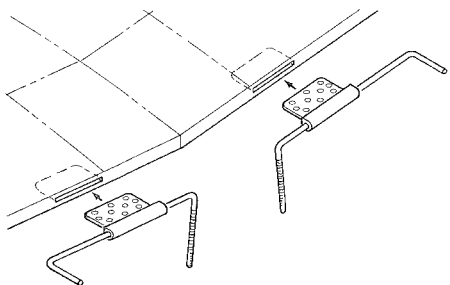

- 44. Use an X-acto knife to cut slots into the center of the wing trailing edge, at the locations shown on the plan for the aileron torque rods. Insert the torque rod bearing blocks into the slots, as shown. **Do not** glue the bearing blocks to the wing at this time.

Note: The **threaded** ends of the torque rods are to face **down**. The **unthreaded** ends of the torque rods are to face **away** from the wing, as shown.

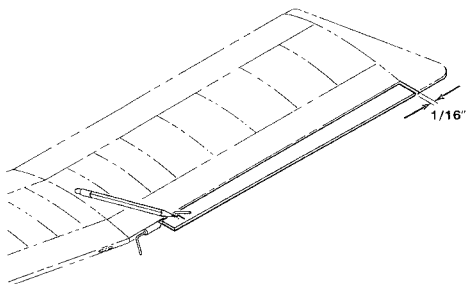

- 45. Position the ailerons against the trailing edge of the wing, as shown here and on the plan. Allow a 1/16" gap between the ends of the ailerons and the wing tips.
- 46. Slide the torque rods sideways in the bearing blocks until they are aligned as shown on the plan. Then, mark the location of the torque rod ends on the ailerons, as shown.

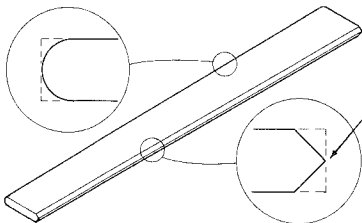

- 47. Using a ruler and pencil, lightly mark the center line on the leading edge of each aileron. Then, using a sanding block, bevel the leading edges of the ailerons, as shown, so that the point of each bevel is on the pencil line. Then, sand the trailing edges of the ailerons to a round section, as shown here and on the plan.

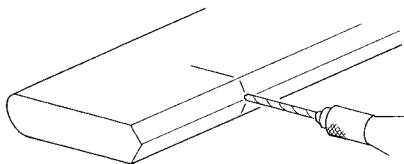

- 48. Drill a $3/32$ " hole into the leading edge of each aileron, at the locations marked for the torque rods, as shown.

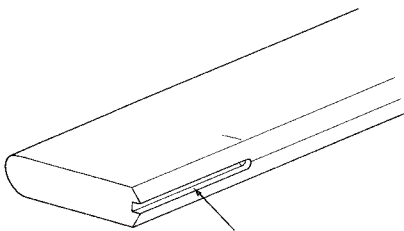

- 49. Using an X-acto knife, cut slots in the ailerons between the $3/32$ " holes and the ends of the ailerons, as shown.

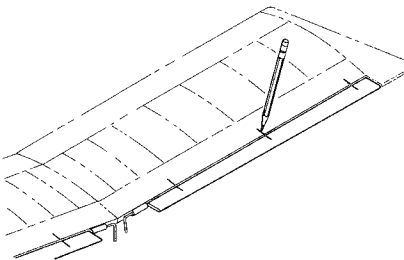

- 50. Insert the torque rod ends into the holes in the ailerons and push the ailerons into contact with the trailing edge of the wing. Use a pencil to mark the locations of the hinges shown on the plan, on the wing and ailerons.

Note: Be sure there is a $1/16$ " gap between the ailerons and wing tips.

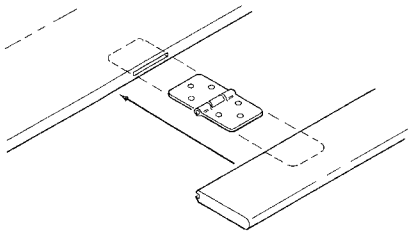

- 51. Following the instructions for the brand of hinges you are using, install the hinges in the ailerons and fit them to the wing. **Do not** glue the hinges to these parts at this time.

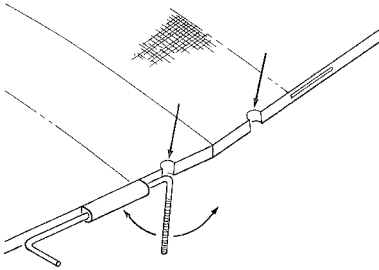

- 52. Using an X-acto knife, cut a slot into the trailing edge of the wing to allow each torque rod to pivot freely, as shown.

Place the wing aside. It will not be needed again until the fuselage is built.

Tail Section

The tail section consists of the Stabilizer, Elevator, Fin and Rudder. These parts must be assembled so that they are flat, with no twists or warps.

Stabilizer And Elevator

You will need the parts illustrated below to complete this sub-assembly. The stabilizer leading and trailing edges and the elevator are in Bag Number Three (#3). The stabilizer tips are in Bag Number Five (#5). The elevator tips are in Bag Number Six (#6).

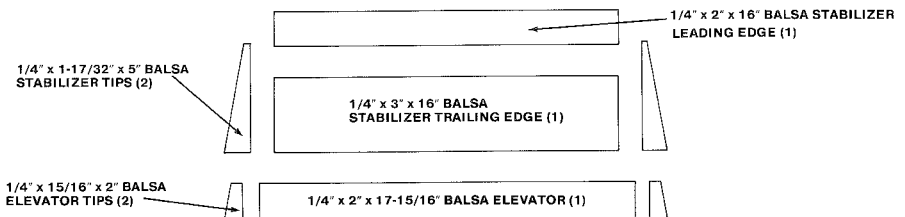

Note: You will also need six (6) hinges, not supplied with the kit, to complete this sub-assembly.

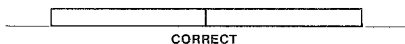
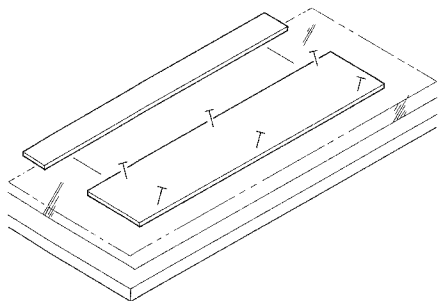

- 53. Lay the plan on your building board so that the drawing of the stabilizer and elevator is completely on the building board. Then, cover the drawing of the stabilizer with plastic wrap.
- 54. Lay the stabilizer trailing edge on the plan. Align it with the drawing of this part and pin it to the plan and building board.
- 55. Align the stabilizer leading edge over the drawing of this part on the plan and press it into contact with the stabilizer trailing edge, as shown. If there are any gaps in the joint between these parts, remove the gap by sanding the mating edge of the stabilizer leading edge with a sanding block until the joint is tight.
- 56. Apply Slow CA to the edge of the stabilizer leading edge. Lay it flat on the building board. Align the ends of the two parts so they are flush and press them together.

Note: When pressing the stabilizer parts together, be sure that both parts are **flat** on the board so that the edges are flush, as shown.

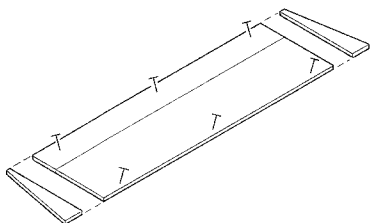

- 57. Using the stabilizer drawing as a guide, glue the stabilizer tips to the ends of the stabilizer with Slow CA.

Note: The edges of the stabilizer parts that contact the tips have end grain. If you are using a brand of Slow CA that soaks into the end-grain, be sure to pre-glue the end grain as described in "Using Adhesives", Page #7.

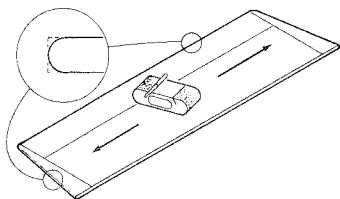

- 58. Remove the stabilizer from the plan. Lay it flat on your building board and lightly sand the joints, on both sides, with a sanding block to remove any raised spots at the joints.
- 59. Using a sanding block, round off the corners of the stabilizer tips. Then, sand the leading edge and tips to a round section, as shown here and on the plan. **Do not** sand the trailing edge. It is to remain square.

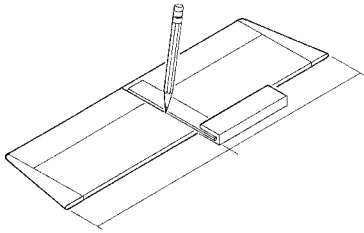

- 60. Using a ruler and pencil, locate the **center** of the stabilizer trailing edge. Then, use a square and pencil to **lightly** mark the centerline on the stabilizer.

Note: Measure and mark the centerline **accurately**. This line will be used to position the stabilizer and fin, later in construction.

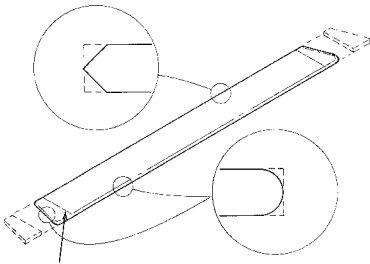

- 61. Using the plan as a guide, glue the elevator tips to the elevator with Slow CA. Then, use a sanding block to sand the elevator tips and the trailing edge of the elevator to a round section, as shown. Also, mark the center of the leading edge with a pencil and bevel this edge, as explained in Instruction #47.
- 62. Align the stabilizer with the elevator, as shown on the plan. Use a pencil to mark the locations of the hinges, shown on the plan, onto the stabilizer and elevator. Temporarily install the hinges, as explained in Instructions #50 and #51. **Do not** glue the hinges in place at this time.

Place the stabilizer and elevator aside. They will not be needed again until the fuselage is built.

Fin and Rudder

You will need the parts illustrated below to complete this sub-assembly. They are all packed in Bag Number Six (#6). Note that the dorsal fin, shown on the plan, will not be used at this time.

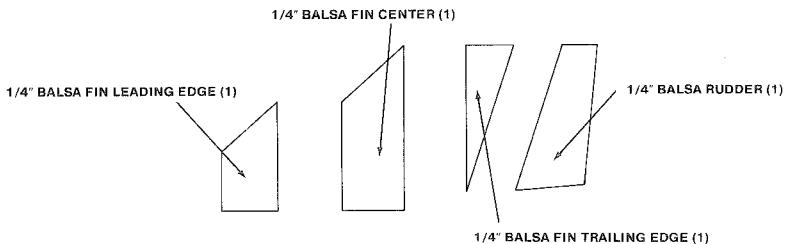

You will also need three hinges, not supplied with the kit, to complete this sub-assembly.

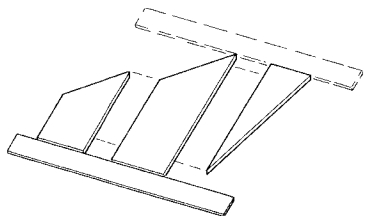

- 63. Lay the plan on your building board so that the drawing of the fin and rudder are completely on the building board. Then, cover the drawing of the fin with plastic wrap.
- 64. Using the same procedures as explained in Instructions #54 thru #56, glue the fin leading edge, fin center and fin trailing edge together with Slow CA, as shown.

Note: When gluing the fin parts together, use a straight edge, as shown, to align the bottom edges of the fin leading edge and fin center parts so they are flush. Then use the ruler in the same manner to align the top edges of the fin center and fin trailing edge so they are flush.

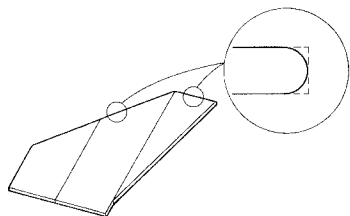

- 65. Remove the fin from the plan. Use a sanding block to sand the leading edge and top of the fin to a round section, as shown here and on the plan. **Do not** sand the back of the trailing edge. It is to remain square.

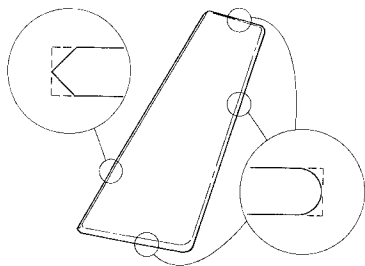

- 66. Use a sanding block to sand the outside edges of the rudder to a round section, as shown here and on the plan. Then, mark the center of the leading edge with a pencil line and use a sanding block to bevel this edge, as explained in Instruction #47.
- 67. Align the fin and rudder, as shown in the fuselage side view on the plan. Use a pencil to mark the locations of the hinges, shown on the plan, onto the fin and rudder. Temporarily install the hinges as explained in Instructions #50 and #51. **Do not** glue the hinges in place at this time.

Place the fin and rudder aside. They will not be needed until the fuselage is assembled.

Fuselage

The fuselage is a simple box structure which is assembled on your building board. Since the fuselage holds the engine, wing, and tail section in their proper relative alignment, it must be built straight, and without twists. Accurately measure and locate all of the parts, as per the instructions.

Fuselage Assembly

You will need the parts illustrated below to complete this sub-assembly. The fuselage sides and dowel supports are in the bottom of the kit box. The wing saddle doublers and forward fuselage bottom are in Bag Number One (#1). The triangle stock is in Bag Number Two (#2). F-1 through F-4, fin supports, balsa top sheeting and the landing gear blocks are in Bag Number Five (#5). The dorsal fin and stabilizer gussets are in Bag Number Six (#6). The motor mounts, nose gear bearing block, steering arm and all screws and t-nuts are in the Hardware Bag.

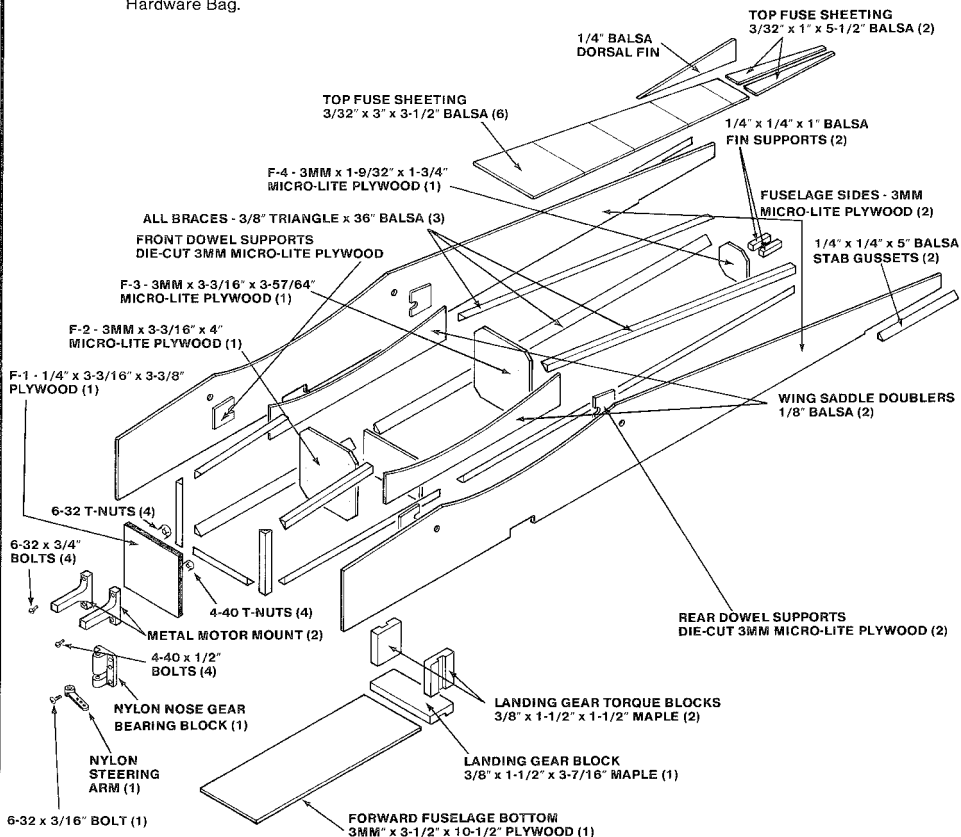

You will also need the previously built stabilizer and fin to complete this sub-assembly.

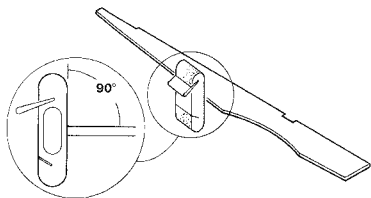

- 68. Use a 36" straight edge to check the **flatness** of your building board, as explained in Instruction # 1.
- 69. Remove the fuselage sides from the die-cut sheets. **lightly** sand the edges of these parts with a sanding block to remove any burrs or rough spots.

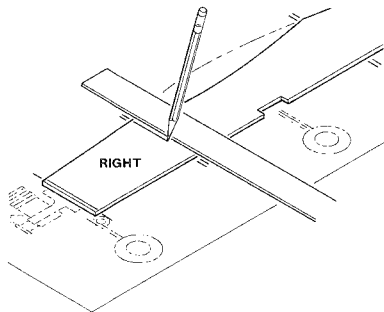

- 70. Lay the plan on the building board so that the drawing of the fuselage side is completely on the building board.
- 71. Lay **one** fuselage side on the plan and align it over the drawing of the fuselage side. Align a ruler with the extended lines for F-1 thru F-4, on the plan, and draw these lines across the fuselage side, as shown. Then, write the word **right** on this side.

Note: Align the fuselage side so that its front edge is even with the front of F-1, the top and bottom edges are just touching the inside of the top and bottom sheeting, and the notch for the stabilizer is just touching the stabilizer on the plan.

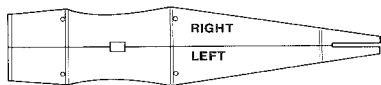

- 72. Lay the two fuselage sides so that the bottom edges are aligned, as shown. Use a ruler and pencil to transfer the locations of F-1 thru F-4 to the other fuselage side and write the word **left** on that side, as shown.

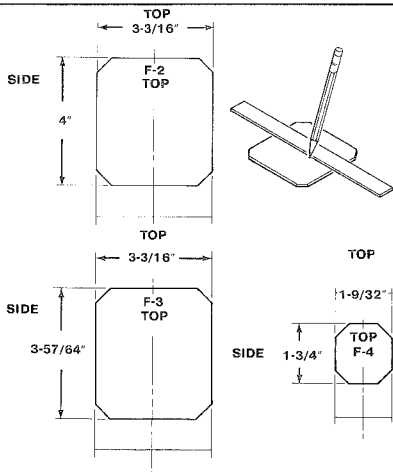

- 73. Use a ruler to locate the center of formers F-2, F-3 and F-4. Then, use a square to draw centerlines on these formers. Also, mark their names and **top**, as shown.

Note: Formers F-2 and F-3 are **not** the same height. F-2 is 4" high and F-3 is 3-57/64" high. Measure these parts with a ruler to identify them.

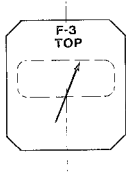
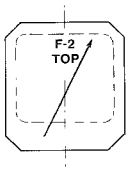

- 74. Use an X-acto knife to cut the openings in F-2 and F-3, as shown on the plan. The hole in F-2 can be larger, or smaller than shown to fit your fuel tank.

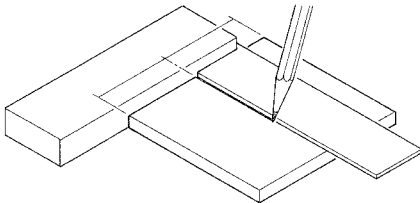

- 75. Use a ruler to locate the **top** center of former F-1. Use a square to draw a vertical centerline on this former, as shown.

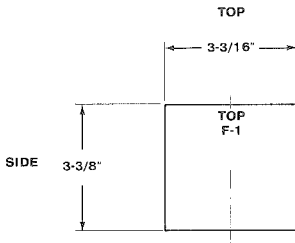

Note: F-1 is not square. Use a ruler to determine the sides and top, as shown here. Write F-1 and **top** on this part, as shown.

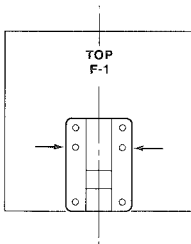

- 76. Position the nose gear bearing block on F-1 so it is **centered** over the vertical centerline and its bottom edge is flush with the bottom of F-1, as shown here and on the plan. Also, be certain that the slot in the bearing block, for the steering arm, is located as shown on the plan. Then, mark the hole locations with a pencil.

Note: The center holes (arrows) on the nose gear bearing block are not used. **Do not** mark their locations.

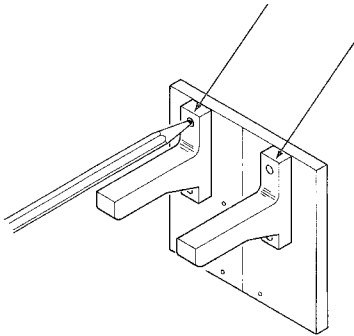

- 77. Determine the proper spacing of the motor mounts by fitting them to your engine. Position the two motor mounts on F-1 so they are properly spaced and centered relative to the vertical centerline, and so that their top edges are flush with the top edge of F-1, as shown. Then, mark the hole locations with a pencil.

Note: Be sure the top edges of the motor mounts are **flush** with the top edge of F-1, as shown. This locates the motor mounts vertically on F-1 and insures that they clear the steering arm and steering pushrod, which will be installed later in construction.

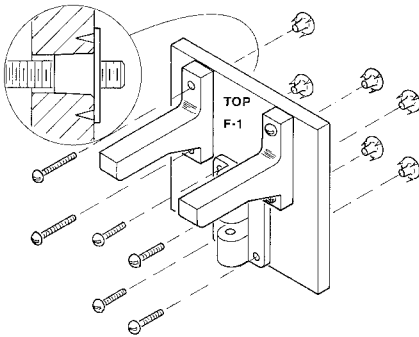

- 78. Drill through the marked locations for the **motor mounts** with a 5/32" drill bit. Drill through the marked locations for the **nose gear bearing block** with a 1/8" drill bit.
- 79. Insert the four (4) 6-32 t-nuts into the 5/32" holes in F-1. Insert the four (4) 4-40 t-nuts into the 1/8" holes in F-1. Place the motor mounts in position, as shown, and fasten them to F-1 with the four 6-32 x 3/4" machine screws. Fasten the nose gear bearing block to F-1 with the four 4-40 x 1/2" bolts. Turn all of the screws and bolts into the t-nuts to draw the t-nuts up flush with the back of F-1, as shown.

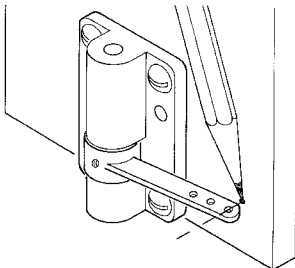

- 80. Temporarily position the nylon steering arm into the nose gear bearing block so that it faces the **left** side, as shown here and on the plan. Make a pencil mark above, and in line with, the outside hole in the steering arm, as shown. This mark will locate the steering pushrod.

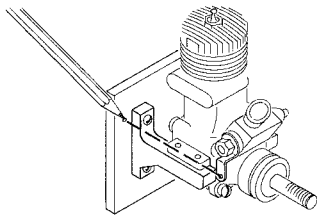

- 81. Position and install your engine on the motor mounts.

Note: The engine can be fastened to the motor mounts with nuts and bolts (not supplied). Or, the motor mounts can be tapped so that the engine bolts screw into the mounts.

- 82. Mark the location of the throttle pushrod, as shown here and on the plan.

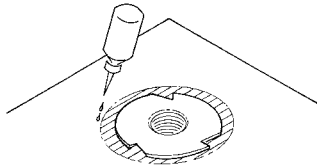

- 83. Remove the motor mounts and nose gear bearing block from F-1.
- 84. Drill through the marked locations for the steering and throttle pushrods with a 1/8" drill bit.
- 85. Place a drop of CA on F-1, next to each t-nut, to hold them in place, as shown.

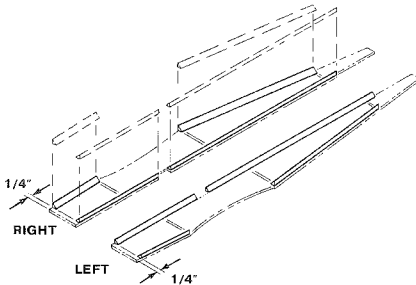

- 86. Lay the fuselage sides flat on your building board so that the penciled lines are facing up, as shown.
- 87. Using the plan as a guide, cut the fuselage braces from the 3/8" x 36" triangle stock. Apply Slow CA to the braces and glue them flush with the edges of the fuselage, as shown here and on the plan.

Note: The top rear braces end at the back edge of F-4, as shown in the fuselage top view on the plan. Also save the remaining triangle stock. It will be used later in construction.

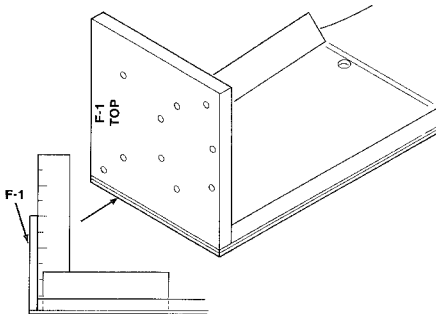

- 88. Lay the **right** fuselage side flat on your building board. Apply Slow CA to the right edge of F-1 and press it into position. Use a square to align F-1 perpendicular to the fuselage side. The front side of F-1 is to be positioned flush with the front edge of the fuselage, as shown.

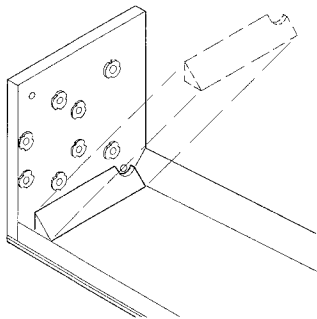

- 89. Cut a piece of triangle stock to fit against the fuselage side and the back of F-1, as shown. If necessary, cut away any portion of this brace that covers any holes. Glue this brace in position with Slow CA.

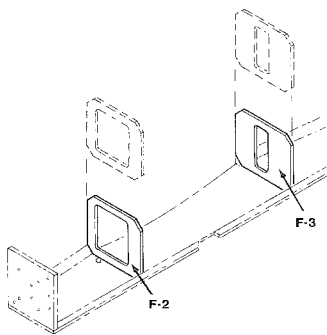

- 90. Apply Slow CA to F-2 and F-3 using the penciled lines and a square to position these frames.

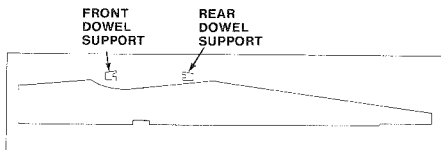

- 91. Remove the front and rear dowel supports from the two die-cut fuselage sheets.

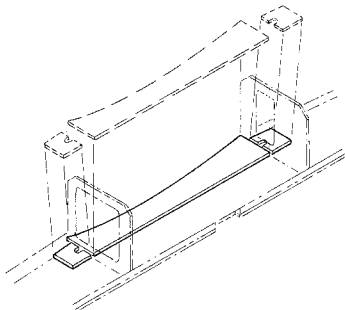

- 92. Test-fit one wing saddle doubler between F-2 and F-3. If necessary, sand the ends of the doubler to fit snugly between these frames. Apply Slow CA to the doubler. Glue it in position with its top edge flush with the top of the fuselage side, as shown here and on the plan.

Apply Slow CA to one front and one rear dowel support. Position these parts against the fuselage side so that their slots are aligned over the holes in the fuselage side, as shown on the plan.

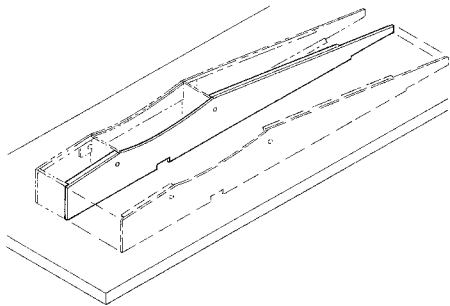

- 93. Test-fit the left fuselage side on the assembled right side and frames by joining these parts and laying them on your building board, as shown. The bottom edges of both sides should contact the board along their full length. If necessary, trim the diagonal corners of F-2 and F-3 to obtain this fit. Then, apply Slow CA to the edges of F-1, F-2 and F-3, and press the left fuselage side into contact with all of the frames, as shown.

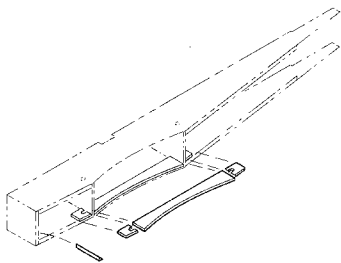

- 94. Lay the fuselage on its **left** side. Fit and glue the wing saddle doubler and dowel supports to the left side with Slow CA, as explained in Instruction #92. Also, use Slow CA to glue a piece of triangle stock to the back of F-1 and the **left** fuselage side, as in Instruction #89.

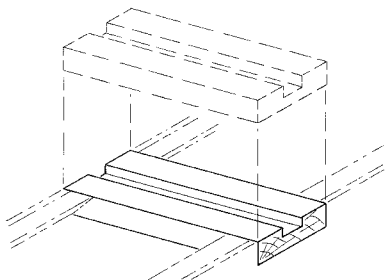

- 95. Test-fit the landing gear block into the slot in the bottom of the fuselage. If necessary, sand the slot so that the landing gear block sits flush with the bottom edges of the fuselage, as shown. Then, apply Slow CA to the edges of the slot. Glue the landing gear block into position, so it's ends are flush with the fuselage sides, as shown.

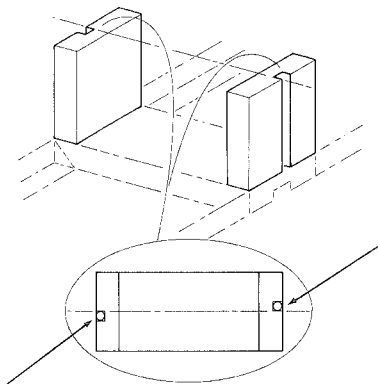

- 96. Apply Slow CA to the torque blocks and glue them to the fuselage sides and landing gear block, as shown here and on the plan. Be certain that the slots in these blocks are staggered and that their edges are flush with the landing gear block, as shown here
- 97. Insert a 5/32" drill bit into the slot in each torque block and drill through the landing gear block.

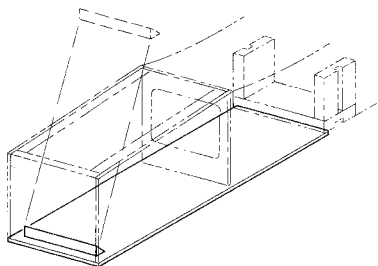

- 98. Use a sanding block to remove any rough edges from the bottom of the fuselage, so that the Micro-Lite® plywood forward fuselage bottom will contact the fuselage sides and the frames.
- 99. Lay the forward fuselage bottom on your building board. Apply Slow CA to the portions of the bottom of the fuselage, frames and landing gear block that will contact the forward fuselage bottom. Align the fuselage on the forward fuselage bottom so that the edges are flush, and press the parts together. Then, use Slow CA to glue a piece of triangle stock to the back of F-1 and the fuselage bottom, as explained in Instruction #89.

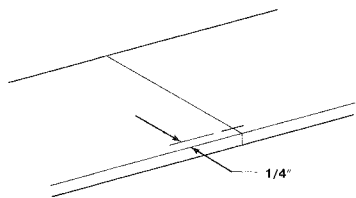

- 100. Measure and mark a line across the centerline of the stabilizer, 1/4" forward of the trailing edge, as shown.

Note: Remove the elevator, rudder and hinges from the stabilizer and fin. They will not be needed at this time.

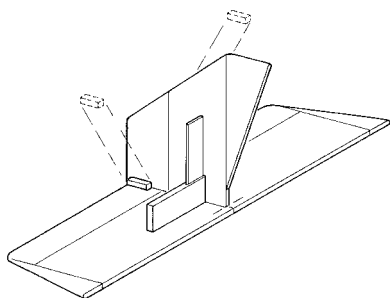

- 101. Apply Slow CA to the bottom of the fin. **Center** the fin on the centerline of the stabilizer so that its trailing edge is flush with the line drawn in Instruction # 100. Use a square to hold the fin perpendicular to the stabilizer, as shown.
- 102. Use CA to glue the fin supports to the stabilizer and fin, as shown here and on the plan.

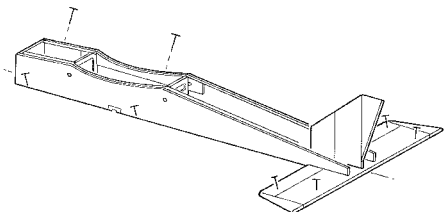

- 103. Lay the plan **flat** on your building board so that the fuselage top view is completely on the board.
- 104. Lay the stabilizer on the plan so that the centerline of the stabilizer is aligned over the centerline on the plan. Then, pin the stabilizer to the plan and building board.
- 105. Lay the fuselage on the plan so that the centerlines of F-1 and F-3 are over the centerline on the plan and the front of the stabilizer slot is butted against the stabilizer. Then, pin the fuselage sides, near F-1 and F-3, to the plan and building board, as shown.

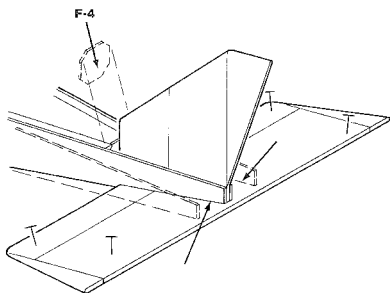

- 106. Pull both fuselage sides into contact with the trailing edge of the fin, and against the stabilizer, as shown here and on the plan. At the same time, position F-4 against the front of the fin, as shown on the plan. Then, apply CA to the joints between these parts.

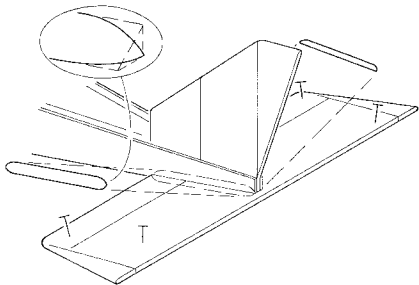

- 107. Use a sanding block to fair both ends of the stabilizer gussets, as shown. Apply Slow CA to the gussets and glue them in position against the stabilizer and fuselage, as shown.

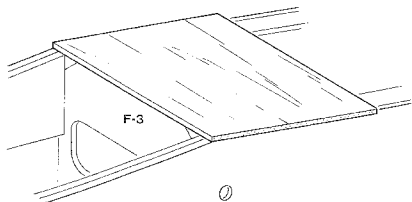

- 108. Apply Slow CA to the top of F-3, and to the tops of the braces and fuselage sides for three inches behind F-3. Position one $\frac{3}{32}$ " x 3" x $3\frac{1}{2}$ " balsa sheet so that it is flush with the edge of F-3, as shown. Then, press it into place.

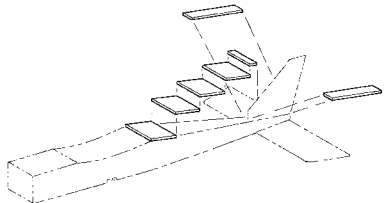

- 109. Use Slow CA to apply the remaining $\frac{3}{32}$ " x 3" x $3\frac{1}{2}$ " balsa sheets and the two $\frac{3}{32}$ " x 1" x $5\frac{1}{2}$ " balsa sheets to the fuselage top, as shown. Then, remove the fuselage from the plan. Use an X-acto knife and sanding block to trim the fuselage top sheeting flush with the fuselage sides.

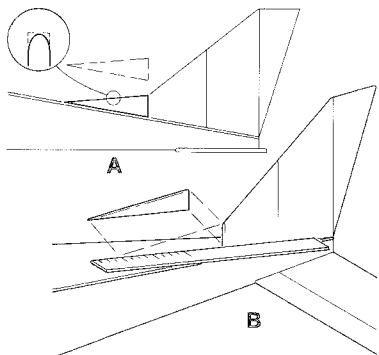

- 110. Fit the dorsal fin against the top sheeting and the leading edge of the fin, as shown in (A). If necessary, sand the mating edges of the dorsal fin for a tight fit between these parts. Sand the leading edge of the dorsal fin to a round section, as shown. Then, apply Slow CA to the dorsal fin and glue it in position. Lay a straight edge against the fin and use it as a guide to position the dorsal fin, as shown in (B).

Radio Installation

At this point in construction the lower rear and upper forward portions of the fuselage are open, which will allow you to easily install the radio and control linkages. Since this is a sport model, it is assumed that the builder has prior experience installing radios and making up pushrods and linkages. Therefore, the following general instructions only highlight the fitting and installation of these parts and components.

You will need the parts illustrated below to complete the sub-assemblies in this section. The balsa pushrods are in Bag Number Two (#2). The servo rails and aileron servo mounts are in Bag Number Five (#5). The steering pushrod is in the bottom of the kit box. The remaining items are in the hardware bag.

1/16" x 12" UNTHREADED WIRE ELEVATOR & RUDDER PUSHROD ENDS (1)



1/8" x 14" NYLON STEERING GUIDE TUBE (1)

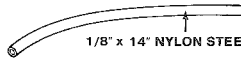

.047 x 18" WIRE STEERING PUSHROD (1)

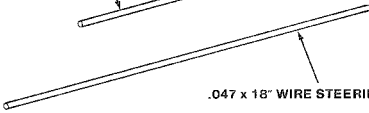

1/16" x 10" THREADED ROD (4)

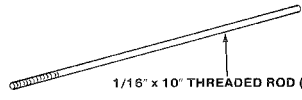

NYLON CLEVIS (4)



AILERON ADJUSTMENT FITTING (2)

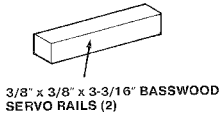

3/8" x 3/8" x 3-3/16" BASSWOOD SERVO RAILS (2)

NYLON CONTROL HORN (2)

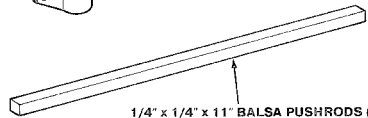
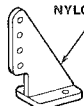

1/4" x 1/4" x 11" Balsa PUSHRODS (2)

1/8" x 1/2" x 2" PLYWOOD AILERON SERVO MOUNTS (2)



NYLON MOUNTING PLATE (2)



2-56 x 1/2" MACHINE SCREWS (4)



You will also need six (6) servo connectors, about four feet of strong string, and a flexible throttle cable with connectors, not supplied with the kit.

Fuselage

The complete radio and linkage installation for the fuselage components is shown on the plan and should be used to position the servos and tail horns. By way of example, the Fuselage Top View on the plan shown the servos three abreast, while the Fuselage Side View shows a two-plus-one servo arrangement. Either installation is acceptable. If you wish, a plastic servo tray can be installed in this model.

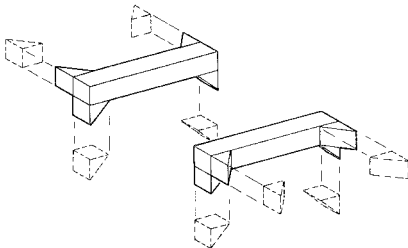

When installing the servo rails, it would be a good idea to glue scrap triangle stock on the bottom and back side of these rails as shown, to provide a strong joint with the fuselage. All of these parts can be glued in place with Slow CA. For clarity, this bracing has not been shown on the plan.

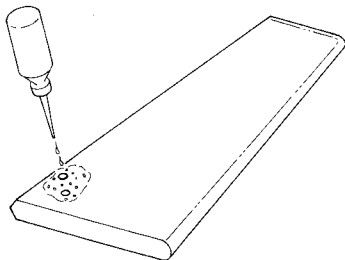

The control horns are mounted directly to the balsa elevator and rudder. After drilling $1/16$ " holes for the horn mounting screws, punch pin holes half way through both sides of the control surfaces in the area of the drilled holes. Flow CA onto the areas that have the pin holes in them. The CA will soak into the balsa and harden it, providing a firm base for the control horns.

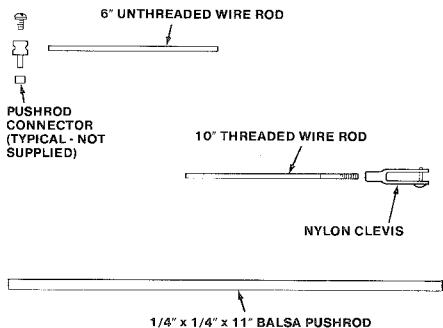

After installing the servos and control horns, make up the pushrods as shown on the plan. The **unthreaded** ends of both pushrods are made by cutting the $1/16$ " x 12" wire in half. The ends of each rod should be bound to the pushrods with strong string, as shown on the plan, and then coated with epoxy, or CA, to create a strong joint.

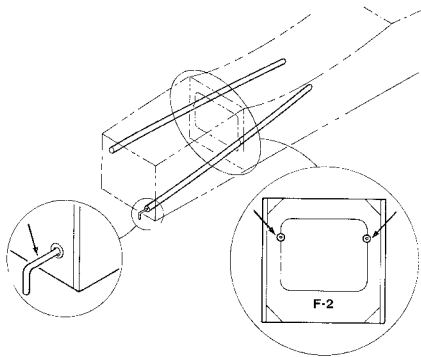

The steering pushrod is made up from the nylon guide tube and 18" wire supplied in the kit.

Most commercially available throttle pushrods also use a nylon guide tube. Insert the guide tubes for both of these pushrods through the holes in the firewall. Notch F-2, as shown, to recess these tubes. One end of the steering pushrod should be bent 90° to fit into the steering arm, as shown.

Wing

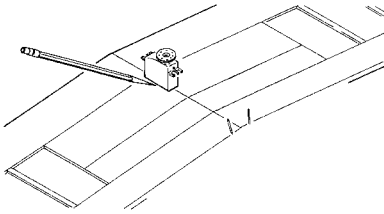

Center your aileron servo over the joint between the wing panels on the underside of the wing, at the position shown in the side view on the plan and as shown here. Mark the location of this servo with a pencil.

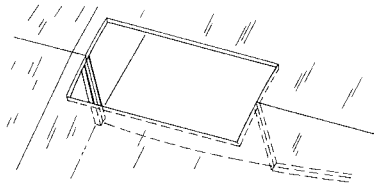

Cut away the center section sheeting inside the pencil line. Then, slice through the root ribs, as shown. Remove the cut-away portions of the root ribs by grabbing them with a pair of pliers and twisting them free.

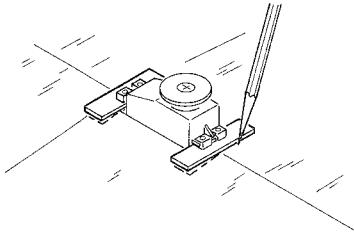

With the aileron servo centered in the hole, position the aileron servo mounts and mark their locations.

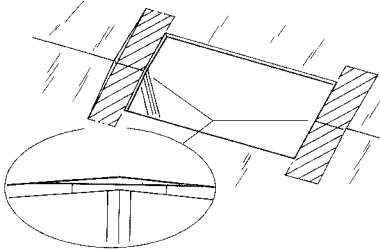

Remove the servo and servo mounts. Use an X-acto knife to scrape the wing sheeting that will be covered by the servo mounts until those areas are flat, as shown. Then, glue the servo mounts in place with Slow CA.

1/16" x 10" THREADED WIRE RODS

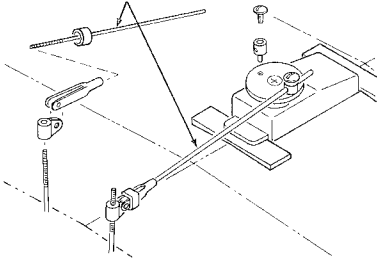

Install the aileron servo and make up the pushrods, as shown here and on the side view of the plan.

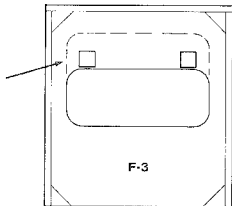

After installing all of the linkages, operate the radio and check to be sure that all linkages operate freely. If the aileron torque rods hit F-3, enlarge the hole in F-3, as shown, to allow these rods to move freely.

After completing the radio installation, remove the radio, pushrods and linkages. This will ease the remaining construction and finishing of the model.

Final Assembly

At this time check to be sure that all radio, pushrods and linkages have been removed from the model. This will ease final assembly and finishing.

Fuel Tank

A fuel tank floor is shown in the fuselage side view on the plan. If you wish, this floor can be omitted, and the fuel tank supported entirely by foam rubber. Should you choose to install a fuel tank floor, you will need two of the 1/8" x 3" x 3-1/2" balsa sheets from Bag Number Five (#5). You will also need a fuel tank to complete this sub-assembly.

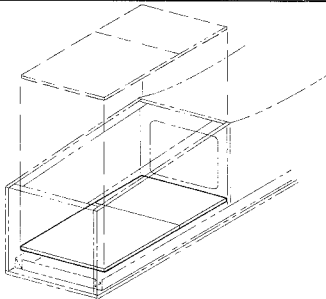

- 111. Assemble your fuel tank as per the manufacturer's instructions.
- 112. Pass the fuel tank through the opening in F-2, to be sure it can be installed and removed easily.
- 113. Position the fuel tank so that its top side clears the forward fuselage top, as shown on the plan.

Note: If you are installing a fuel tank floor, cut the two balsa sheets to fit tightly against F-1 and the fuselage sides, as shown here and on the plan. Glue them in place with CA.

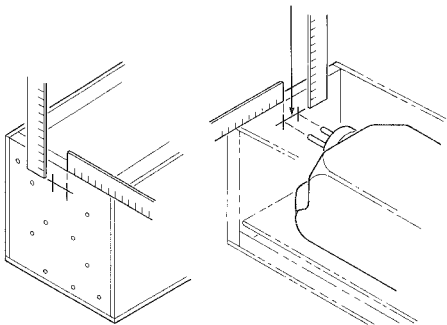

- 114. With the fuel tank in position, mark the locations of the fuel lines on the back side of F-1. Use a ruler to measure and transfer them to the front side of F-1, as shown.

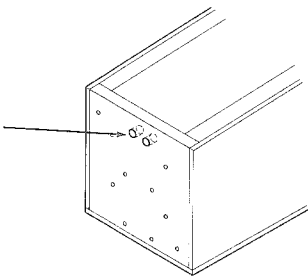

- 115. Drill through the fuel line location marks on F-1 with a 1/4" drill bit. Remove any burrs or rough edges from the holes with a piece of sandpaper.

Remove the fuel tank. It will not be needed again until the model has been finished.

Fuselage Sheeting

You will need the following parts to complete this sub-assembly: a short piece of balsa triangle stock from Bag Number Two (#2), the two 1/4" x 5" wing dowels from Bag Number Six (#6), the 1/8" x 1-5/16" x 3-7/16" plywood landing gear cover plate from Bag Number Five (#5), the 3/16" x 3-1/2" x 6-3/4" balsa forward fuselage top from Bag Number Six (#6), and the remaining 1/8" x 3" x 3-1/2" balsa bottom sheets from Bag Number Five (#5).

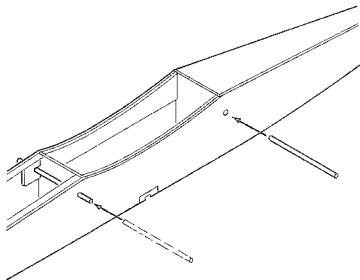

- 116. Fit the 1/4" wing dowels into the holes in the fuselage, as shown. If necessary, adjust the size of the holes with an X-acto knife so that the dowels slip through them. **Do not** glue the wing dowels in place at this time.

Note: After the model is finished, the rear dowel will be permanently glued in place. The front dowel will be removable, to allow installation and removal of the fuel tank through the hole in F-2.

Note: Normally, the forward fuselage top sheet on sport models is built as a removable hatch, to provide access to the fuel tank. Although convenient, that method severely weakens the forward fuselage and amplifies engine vibration, thereby shortening the model's service life. We have found that the removable wing dowel is a better method.

- 117. Remove the wing dowels and place them aside.

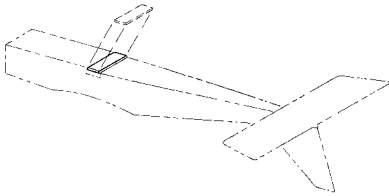

- 118. Lay the fuselage upside down on your work bench so that the fin hangs over the edge. Lay the plywood landing gear cover plate over the slot in the landing gear block and butt it against the plywood forward bottom sheet, as shown.

Note: Do not glue the cover plate to the landing gear block. In the following instruction, it will be used to locate the 1/8" bottom sheeting.

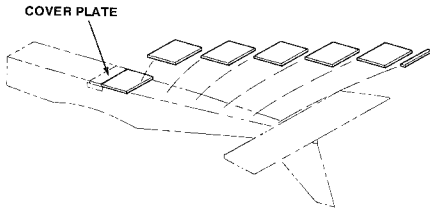

- 119. Fit and glue the remaining 1/8" balsa sheets to the bottom of the fuselage with Slow CA, as shown. Start by positioning the first sheet against the landing gear cover plate. Then, remove the plate and install the remaining balsa sheets.
- 120. Use an X-acto knife and a sanding block to trim the bottom sheeting flush with the sides.

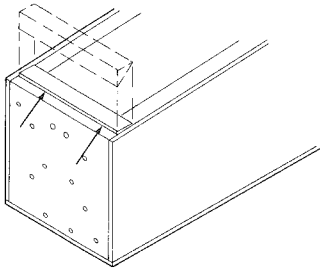

- 121. Cut a piece of triangle stock to fit between the fuselage side braces and against F-1. Glue this part in place with Slow CA so that it is raised slightly above the top edge of F-1, as shown.

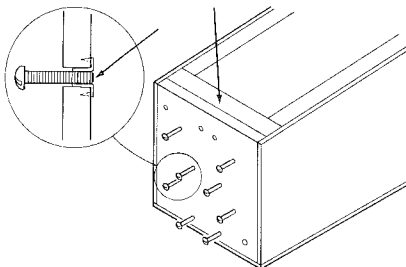

- 122. Use a sanding block to remove any rough edges from the top of the forward fuselage and to sand the triangular brace flush, so that the forward fuselage top will contact the fuselage sides and F-1 and F-2.
- 123. Apply light oil to the motor mount and nose gear bearing block screws. Turn them into the t-nuts in F-1 until they are flush with the back of the t-nuts, as shown.

Note: The oiled screws will prevent epoxy from fouling the threads in the t-nuts.

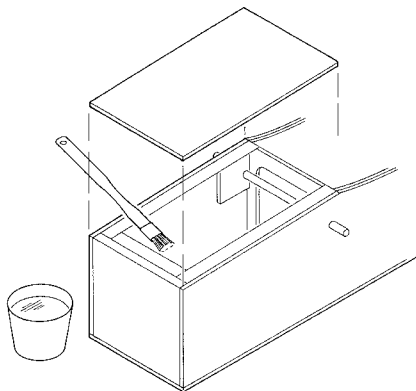

- 124. Mix about two ounces of slow curing epoxy and brush it onto the inside of the fuel tank compartment. At the same time, brush epoxy onto the entire underside of the forward fuselage top. Then, pin the fuselage top in position, as shown here and on the plan. Allow the epoxy to cure before going on.

Note: If you do not wish to fuel proof the fuel tank compartment, simply glue the forward fuselage top in place with Slow CA.

- 125. Use a sanding block to sand all of the joints on the fuselage flush and smooth. Also, round off the square corners on the fuselage sides.

Wing Incidence

Incidence is the angle at which air strikes the wing as the model flies through it. This angular difference effects the quality of the models performance. At this time, the wing's incidence will be adjusted.

You will need the previously built wing and the two 1/4" x 5" wing dowels used in Instruction # 116 to complete this sub-assembly. You will also need two #64 rubber bands, not supplied with the kit.

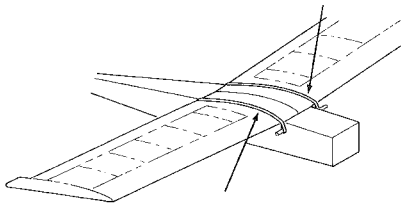

- 126. Center the wing dowels in the holes in the fuselage. **Do not** glue them in place. Then, remove the ailerons from the wing and place the wing on the wing saddle. Hold it in place with two #64 rubber bands, as shown.

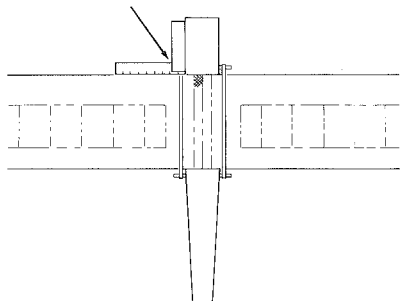

- 127. Position the wing on the wing saddle so that the joint between the wing panels is centered on the fuselage and the wing leading edge is butted against the forward fuselage top. Align the wing square to the fuselage with a square, as shown.

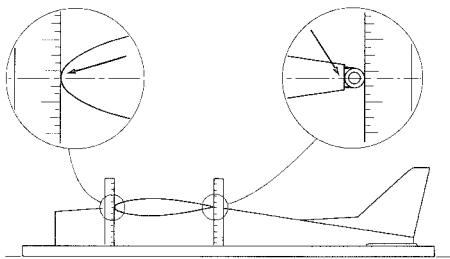

- 128. To measure the wing's incidence, lay the fuselage flat on your building board so that the fuselage bottom and the stabilizer contact the board. Stand a straight edge against one fuselage side and the leading and trailing edge of one wing panel. Measure the distance from the building board to the center of the wing trailing edge. Then, measure the distance from the building board to the point at which the wing's leading edge contacts the straight edge, as shown. When the wing's incidence is correctly set, these two measurements will be the same.

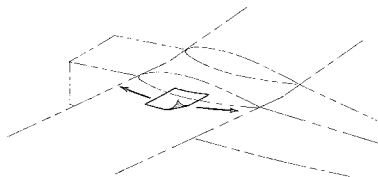

Note: If there is a difference between the height of the wing leading and trailing edges, the incidence can be adjusted by slipping a piece of #80 grit sandpaper between the wing and wing saddle, with the grit side of the sandpaper facing **down** against the wing saddle, as shown. **Lightly** sand the forward or rear portions of the wing saddle, as necessary, by gently pressing down on the wing while moving the sandpaper across the wing saddle. Sand **both** wing saddles to adjust the wing so that the measurements at the wing leading and trailing edges are the same.

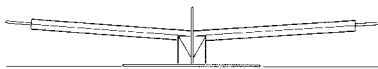

CORRECT



INCORRECT

Also, check the alignment of the wing, relative to the stabilizer, by sighting down the fuselage from the rear. The correct relationship of the wing and stabilizer are shown here. **After** setting the incidence, adjust the wing, relative to the stabilizer, by sanding the wing saddle under the high wing. If necessary, also sand the wing saddle so that the wing rests solidly in place, without rocking.

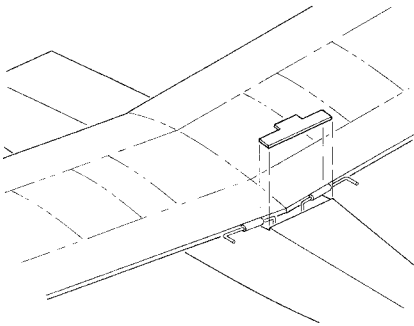

- 129. After setting the wings incidence, re-check the alignment of the wing, as explained in Instruction # 127. Make a filler strip, as shown, from the 3/32" balsa sheeting to fill in the open area between the aileron bearing blocks and the fuselage. Glue this piece in place with Slow CA.

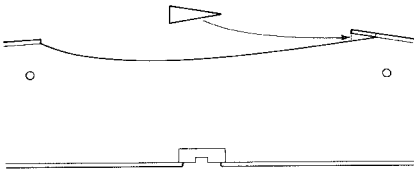

- 130. Remove the wing and wing dowels from the fuselage.
- 131. Fill in the slot between the underside of the filler piece and the wing saddle with scrap balsa, as shown. Glue these scraps in place with CA. Then, use a sanding block to sand these parts flush with the fuselage sides and top.

Landing Gear

You will need the parts illustrated below to complete this sub-assembly. The landing gear legs, nylon steering arm, nose gear bearing block, screws and collar are in the hardware bag. You will also need the landing gear cover plate used in Instructions # 118 and # 119, along with one (1) 2-1/4" wheel, two (2) 2-3/4" wheels, and six (6) 5/32" wheel collars, not supplied with the kit.

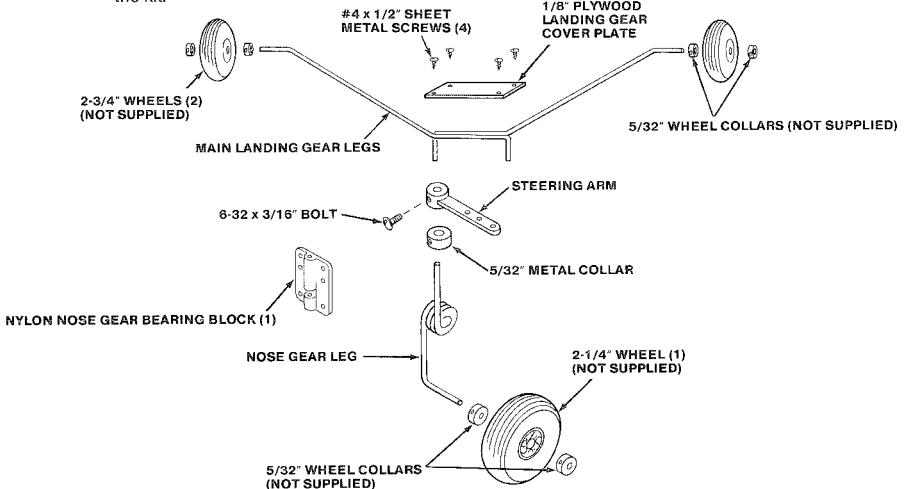

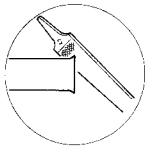

- 132. Inspect both ends of the main gear legs for burrs or rough edges. If any are found, use a flat file to remove them.

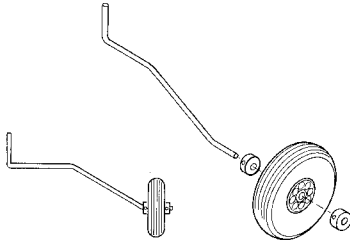

- 133. Install one 2- $\frac{3}{4}$ " wheel and two 5/32" wheel collars on the axles of each main landing gear leg, as shown. The inside collar should be positioned all the way to the inside of the axle. Then, tighten the collars, allowing the wheels to turn freely on the axles, but, preventing them from moving sideways.

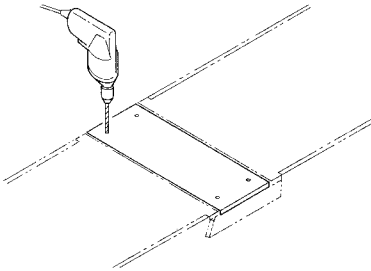

- 134. Position the landing gear cover plate on the landing gear block. If necessary, sand the long edges of the cover plate to allow it to seat down between the bottom fuselage sheeting, as shown. Drill through the cover plate and the gear block with 1/16" drill bit.

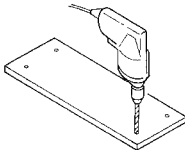

- 135. Remove the cover plate from the landing gear block and drill through the four holes with a 1/8" drill bit.

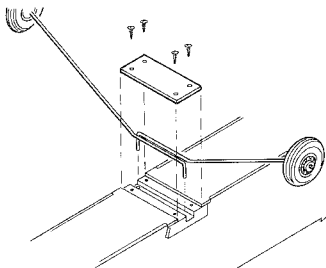

- 136. Insert the main landing gear legs into the pre-drilled holes and slots in the main gear block, as shown. Position the cover plate on the main gear block and secure it with four, #4 x 1/2" sheet metal screws, as shown.

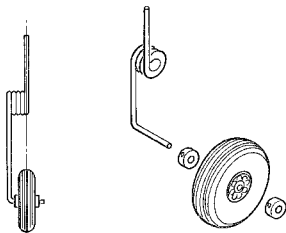

- 137. Place the 2-1/4" wheel and two wheel collars on the nose gear axle. Hold the collars against each side of the wheel and center the wheel on the nose gear leg, as shown. Then, tighten the collars, allowing the wheel to turn freely on the axle, but preventing it from moving sideways.

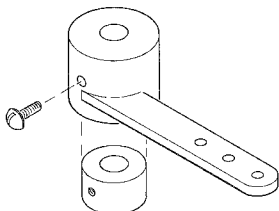

- 138. Insert the 5/32" metal collar into the steering arm. Align the holes in the two parts and screw the 6-32 x 3/16" bolt into the arm and collar, as shown. **Do not** tighten the bolt.

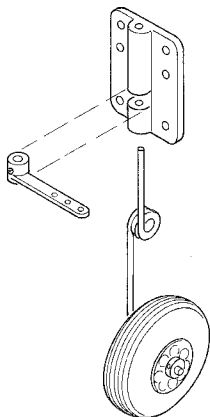

- 139. Position the steering arm in the slot in the nose gear bearing block. Insert the nose gear into the nose gear bearing block and through the steering arm. Push the nose gear up until the coil just clears the bottom of the bearing block. Align the steering arm parallel to the nose gear axle and tighten the screw in the steering arm.
- 140. Remove the landing gear cover plate and landing gear legs from the fuselage, in preparation for finishing your model.

Finishing

The Aero-Sport .40 has a light wing loading and can be covered and finished as you choose. The shape of this model makes the application of iron-on covering materials, such as Super Monokote, very easy. If you should decide to use one of the iron-on covering materials, the following hints may be of some help.

To avoid wasting material, cover small parts, such as the control surfaces, first. Cover large parts last.

If you cover the model from the bottom up, and from the back to the front, the seams will generally be less visible. For example, cover the bottom of the stabilizer first, then the top.

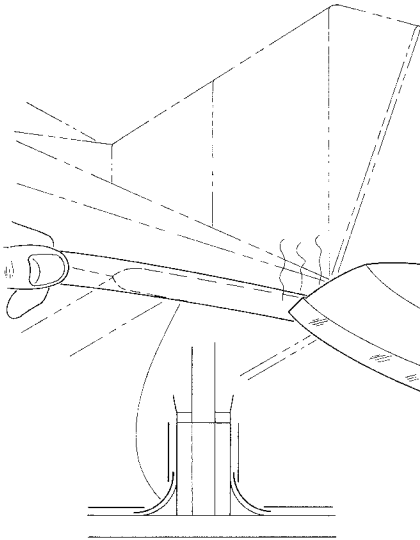

To avoid difficulty covering the stabilizer gussets, use your iron to tack a 1" wide strip of covering to one end of the stabilizer, as shown. Pull gently on the other end while applying heat to the strip with your heat gun. When the material starts to stretch over the gusset, immediately rub it down with a soft cloth. Then, go ahead and cover the stabilizer and fuselage, overlapping the material onto the strip that is covering the gusset, as shown.

The self adhesive mylar decals supplied with the kit are fuel resistant, but not fuel-proof. After application they should be fuel-proofed with a light coat of clear epoxy or urethane to preserve and protect them.

Equipment Installation and Set Up

Since you have already installed most of the radio, components and linkages during construction, their final installation should not be a problem. Therefore, this section will deal only with components not previously discussed.

Fuel Tank Installation

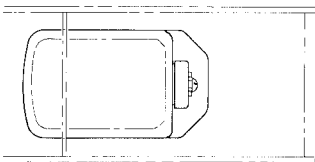

Slip the assembled fuel tank through the hole in F-2. Pass the fuel lines through the holes in F-1 and push the fuel tank forward until it stops. If necessary, adjust the length of the fuel lines so that they stick out of the front side of F-1 about 1/4", as shown in the Fuselage Side View on the plan. Connect the fuel feed and vent tubing to the tank and engine. Pass pieces of foam rubber through the hole in F-2 and place them between the fuel tank and the fuselage to cushion the fuel tank.

Wing Dowels

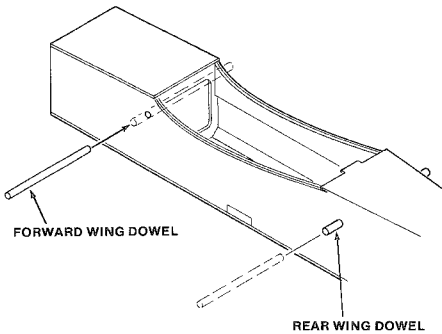

The rear wing dowel is to be glued in position with CA, as shown on the plan. the forward wing dowel is to be removable, to allow access to the fuel tank for removal. Do not glue the forward wing dowel in place.

Note: Normally, the forward fuselage top sheet on sport models is built as a removable hatch, to provide access to the fuel tank. Although convenient, that method severely weakens the forward fuselage and amplifies engine vibration, thereby shortening the model's service life. We have found that the removable wing dowel is a better method.

Receiver and Battery

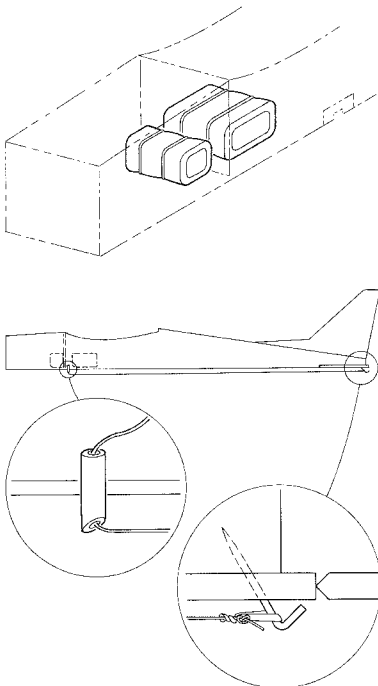

The locations of the receiver and battery pack are shown in the fuselage side view on the plan. Loosely wrap these components in foam rubber to protect them from vibration. The foam rubber can be held in place with rubber bands, as shown. The receiver antenna can be lead out of the wing saddle opening and up to the top of the fin. Or, a 1/4" hole can be drilled through the bottom forward sheet and a short length of fuel tubing inserted into the hole. The antenna can then be lead through this tubing and back along the bottom of the fuselage. Connect the end of the antenna to a wire hook, made from a t-pin, with a small rubber band, as shown. Running the antenna along the bottom of the fuselage will not interfere with wing mounting during normal flight preparations, and the t-pin hook will act as a tail skid, to prevent the stabilizer from hitting the ground during take-offs and landings.

Weight and Balance

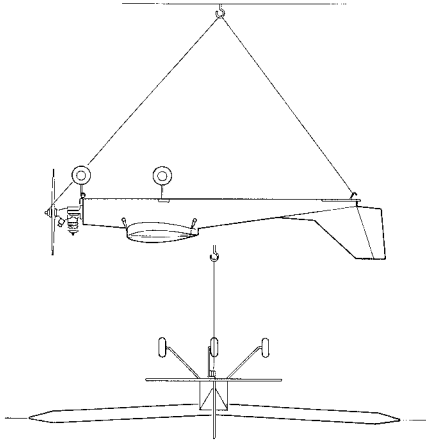

The center of gravity shown on the plan will provide the best all-round performance and we recommend that you make the initial flights with the model balanced at this point. If necessary, add weight to the nose or tail to establish the center of gravity.

Although not critical, any model's performance in looping maneuvers will be improved if the wings are also balanced. To do this, tie a piece of strong string around the prop shaft and the t-pin tail skid with all equipment installed and the model ready to fly. Suspend the assembled model from the ceiling, as shown. Add weight to the light wing until the model hangs in a wings-level attitude.

Note: The best material for wing weight is lead shot mixed with epoxy. It can be poured through a small hole in the wing leading edge sheeting and the hole covered with a small piece of monokote. Lead shot can be purchased at most gun shops.

Control Throws

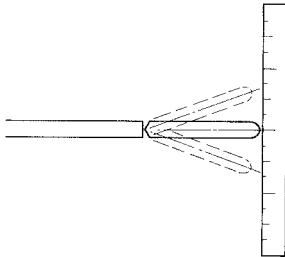

The following control throws are recommended starting points and can be increased or decreased to suit your preference. They are measured at the widest point of each control surface with a ruler, as shown.

Ailerons - 3/8" up, 3/8" down

Note: For dual rate radios, set high rate aileron at 1/2" up, 1/2" down

Elevators - 3/8" up, 3/8" down.

Note: For dual rate radios, set high rate elevator at 1/2" up, 1/2" down.

Rudder - 1" left, 1" right

Flying

The Aero-Sport .40 is a very easy and stable model to fly. With dihedral, turns can be made using the rudder or the ailerons and, if you wish, the model can be flown using three channels. However, the flat wing does require the use of ailerons to perform banked turns.

The Aero-Sport wing will allow it to be flown and landed very slowly, without worrying about tip stalls. The glide ratio is quite good and the model can be landed normally with the engine off. This model's ability to perform aerobatic maneuvers, including inverted flight, is limited only by engine size and your skill as a pilot. Have fun!

We at Midwest Products Company hope you have enjoyed building your Aero-Sport and sincerely wish you the best of times flying it. We would appreciate your taking a few minutes to fill out and return the postage-paid evaluation form in this manual. We welcome any suggestions or comments you may have for improving our kits and instructional material. Thank you.

Product Evaluation Card

What you tell us you like, and don't like, determines what model kits we make and how we make them. We would appreciate it if you would take a few minutes to answer the following questions about this kit and also, tell us a little about your interests. Upon completion of this form, simply fold it in thirds and staple it so that our address faces out, and return it to us. Postage will be paid by Midwest Products.

1. Kit Name _____

2. Kit Number _____

3. Where did you learn about this kit?

- Magazine Ads Friend
 Hobby Shop Other

4. What influenced you the most to buy this kit?

- Box Art Recommendation of Others
 Type of Model Price
 Magazine Ads Other _____

5. Did you have any trouble using the plans?

- Yes No

If yes, please explain. Be specific.

6. Did you have any difficulty understanding any of the written instructions on the plans, or in the construction manual?

- Yes No

If yes, please explain. Be specific.

7. Did you have any difficulty understanding any of the illustrations in the construction manual?

- Yes No

If yes, please explain. Be specific.

8. Did you have any difficulty identifying any of the parts?

- Yes No

If yes, which part(s).

9. If you answered yes to Question 8, which of the following answers best describes the problem?

Could not identify part(s) from:

- Plans Written description in manual
 Isometric views in manual Other _____

10. Were any of the kit parts:

- Missing Wrong Size
 Broken Wrong Shape

11. If you checked off an item in Question 10, please list those part(s) and tell us what was wrong with them.

12. Was any part of the model's construction difficult for you?

- Yes No

If yes, please explain.

13. What did you like most about this kit?

- Plans Wood Parts
 Construction Manual

14. What did you like least about this kit?

- Plans Wood Parts
 Construction Manual Other

If other, please explain. Be specific.

15. Are you satisfied with the finished model?

- Yes No

If no, please explain. Be specific.

16. How does this kit compare to similar kits by other manufacturers?

- Better than As good Not as good

17. Is there anything else you would like to tell us about this kit?

Tell Us About Yourself

18. How long have you been building models?

19. What magazines do you regularly read?

20. Are most of your models built from:

- Plans Kits Scratch built using your own plans

21. What model(s) would you like Midwest to kit in the future?

22. Kit was purchased from:

- Hobby Shop Mail Order Other _____

Name _____

Age _____ Annual Income _____

Address _____

City _____ State _____ Zip _____

Phone (Area Code) _____

Ask For Micro-Cut Quality® Woods

Your retail hobby shop has a full assortment of Midwest's Micro-Cut Quality® Woods for any repairs or modifications you wish to make. You'll find a great selection of:

BALSA - Sheets, Strips, Blocks & Special Shapes
BASSWOOD - Sheets, Strips, Blocks & Special Shapes
MAHOGANY - Sheets, Strips & Blocks
MAPLE - Sheets, Strips & Blocks
POPLAR - Plywood Sheets

BIRCH - Dowels & Plywood Sheets
CHERRY - Sheets & Strips
SPRUCE - Strips
WALNUT - Sheets & Strips
BEECH - Plywood Sheets

Specialty Woods for R/C Models

36" Balsa Triangular Stock

#6707 - 1/4"
 #6708 - 3/8"
 #6709 - 1/2"
 #6711 - 3/4"



36" Balsa Shaped Leading Edge

#6909 - 1/2 x 3/4
 #6911 - 3/4 x 3/4
 #6912 - 1 x 1

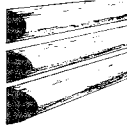

18" Maple Motor Mounts

#9008 - 3/8 x 3/8
 #9009 - 3/8 x 1/2
 #9011 - 3/8 x 3/4
 #9012 - 1/2 x 1/2
 #9013 - 1/2 x 1



24" Balsa Cove Fillet

#6848 - 1/4"
 Perfect for wing and tail fillets. Adds strength!



36" Balsa Aileron Stock

#6840 - 1"
 #6842 - 1-1/4"
 #6844 - 1-1/2"
 Eliminates the need to bevel your trailing edge stock!



36" Balsa Tapered Trailing Edge

#6811 - 3/4"
 #6812 - 1"
 #6813 - 1-1/4"
 #6814 - 1-1/2"



A full list of wood sizes for modeling can be found on our current price list: Balsa, Basswood, Walnut, Mahogany, Cherry, Maple, Spruce, Plywoods, Dowels

If you have trouble obtaining any of these fine woods, please contact our Customer Service Department.

R/C Accessories

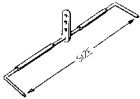

Control Horns

Offered in three popular sizes, our Control Horns are zinc plated and contain brass bushings.

#1029 - 4"
 #1030 - 5"
 #1031 - 6"



#1039 - Microglas Cloth

A lightweight fiberglass cloth weighing 6/10 of one ounce per yard. Ideal for skinning, reinforcing or molding. Package contains one piece 36" x 38".

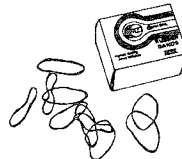

#1043/#1044 - Rubber Bands

Midwest rubber bands are made from fuel-proof rubber crepe. Ideal for holding on your wings, be sure you always use fresh bands when flying. Available in two sizes.

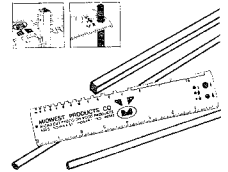

#1125 - Hobby & Craft Ruler

This rugged plastic ruler has slots for measuring thicknesses from 1/64" to 1/2", and dowels from 1/16" to 1/4".