

MIDWEST
Aero-Star .60

1255

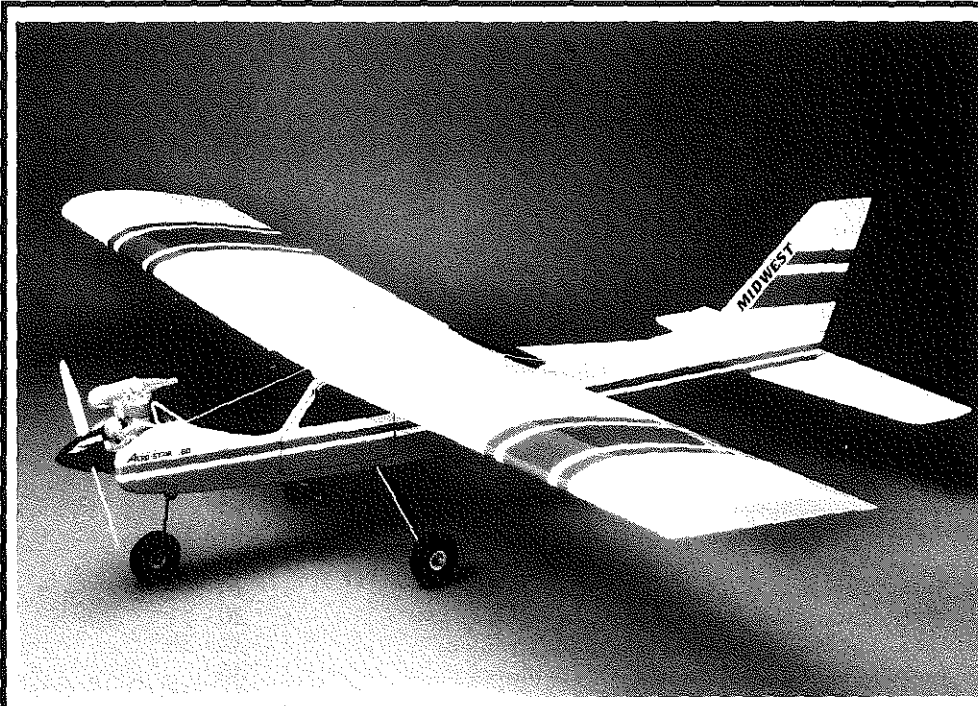

Success Series[®]
This kit features a complete and fully illustrated step-by-step construction manual -AND- full-size plans that ASSURE SUCCESS!

Kit #178
Outshines
All Other
R/C Trainers

About This Construction Manual

This booklet divides the construction into sub-assemblies; wing, fuselage, etc. Read each section carefully and identify all of the parts before starting on a particular sub-assembly. There is a complete description of all kit parts under "Kit Contents", (Pages #3 - #6). Please check to be sure that your kit is complete; that is not missing any parts. If you do find that parts are missing, or you are having trouble identifying parts, see "Customer Service" (below). The instructions give the sizes of all the parts. Refer back to the "Kit Contents" when selecting parts, to be sure that you are using the correct sizes.

This manual shows dimensions in inches and metric, the metric dimensions being given in parenthesis following the inch figures. Example: 3" (76mm) Since there is rarely a direct inch to metric conversion, in many cases a close approximation is quoted.

The illustrations in this manual clarify and detail many of the assemblies shown on the plan, and the two should be used together during construction.

Customer Service

Should you experience a problem with this kit, we recommend you see your dealer first. If you are unable to solve the problem, feel free to call or write:

Customer Service Department
Midwest Products Co., Inc.
P.O. Box 564
Hobart, IN 46342
(219) 942-1134



This product is sold with exclusion of all warranty expressed or implied, statutory or otherwise. Buyer assumes all risk of use.



400 S. Indiana St. P.O. Box 564 Hobart, IN 46342

Table of Contents

		Page No.
I.	About This Construction Manual	
II.	Customer Service	
III.	Kit Contents	
	Tail Surfaces	3
	Fuselage	3 - 5
	Wing	5
	Miscellaneous	6
IV.	Before You Begin	
	The Aero-Star .60	6
V.	Getting Started	
	Tools and Materials You Will Need	6 - 7
	Additional Components	8 - 9
VI.	Construction Tips	
	How To Read The Plans	10
	Cutting	10 - 11
	Using Adhesives	11
	Hinge Installation	11 - 12
VII.	Assembly Instructions	
	Tail Section	13
	Stabilizer and Elevator	13 - 16
	Fin and Rudder	16 - 19
	About the Fuselage	20
	Fuselage Construction	20 - 31
	Firewall	32 - 35
	About the Wings	36
	Wing Construction	36 - 43
	Torque Rods	44 - 45
	Joining the Wing Panels	46 - 48
	Wing Fairing	48 - 50
	Engine and Cowl	51
	Engine Installation	51 - 53
	Cowl Installation	53 - 54
	Landing Gear	55
	Main Gear	55 - 56
	Nose Gear	57 - 58
	Tail Section Installation	58
	Stabilizer	59 - 60
	Fin	61 - 62
	Control Linkages	62
	Servos	63 - 66
	Control Horns	66 - 67
	Rudder and Elevator Pushrods	67 - 72
	Throttle and Steering Pushrods	72 - 76
	Aileron Pushrods	76 - 77
	Finishing Your Model	77 - 78
	Decals	78 - 79
	Wing Dowels	79 - 80
	Hinging the Control Surfaces	80 - 81
	Radio and Equipment Installation	81 - 86
	Control Adjustments	86 - 88
	Control Throws	89 - 90
	Balance	90 - 91
	Flying	91
	Theory of Flight	92
	The Controls	92-95
	Field Equipment	95-96
	Radio and Engine Operation	96
	Radio	97
	Engine	97
VIII.	Your First Flight	98
IX.	Preventative Maintenance	98
X.	Product Evaluation Card/Catalog Offer	99

Kit Contents

Note: All wood parts are Balsa unless noted.

Tail Surfaces

Part no.	Qty.	Dimensions	Metric (mm)	Description
Bag 1				
33334	1	3/8" x 2-7/8" x 26-3/32"	9.5 x 73 x 663	Stabilizer Leading Edge
33326	2	3/8" x 1-23/32" x 26-3/32"	9.5 x 43.7 x 663	Stabilizer Trailing Edge
33333	1	3/8" x 1-7/8" x 27-19/32"	9.5 x 47.6 x 701	Elevator
33328	2	3/8" x 3/4" x 3-7/8"	9.5 x 19 x 98.4	Stab Tips
Bag 2				
33329	1	3/8" x 2-7/8" x 11-5/8"	9.5 x 73 x 295	Fin Trailing Edge
33330	1	3/8" x 2-7/8" x 11-13/32"	9.5 x 73 x 290	Fin Center
33331	1	3/8" x 1-15/32" x 5-1/4"	9.5 x 37.3 x 133	Fin Leading edge
33332	1	3/8" x 1-5/32" x 7-11/32"	9.5 x 29.4 x 187	Dorsal Fin
33327	1	3/8" x 2-13/16" x 11-3/32"	9.5 x 71.4 x 290	Rudder
33335	1	3/8" x 3/8" x 5-7/32"	9.5 x 9.5 x 133	Fin Alignment Tab

Fuselage

Bag 3				
33309	1	1/4" x 3-31/32" x 4-1/8"	6.4 x 101 x 105	Birch Plywood Firewall
33310	1	1/8" x 1-1/16" x 4-3/16"	3.2 x 27 x 106	Birch Plywood Landing Gear Cover
33302	2	1/2" x 4-11/32" x 4-1/8"	12.7 x 110 x 105	Cowl Blocks
33323	1	3/8" x 1-27/32" x 4-3/16"	9.5 x 46.8 x 106	Maple Landing Gear Block
33324	1	3/8" x 1-5/8" x 7/8"	9.5 x 41.3 x 22.2	Maple Left Torque Block
33304	1	1/4" x 1" x 5-11/32"	6.4 x 25.4 x 136	Stab Platform
33312	2	3/8" Dia. x 5-11/16"	9.5 Dia. x 144	Birch Wing Dowel
33301	2	3/8" x 3/8" x 3-3/4"	9.5 x 9.5 x 95.3	Firewall Triangle
33316	2	3mm x 1-27/32" x 5-5/16"	3 x 46.8 x 135	Micro-Lite Plywood Fuselage Doubler
33311	2	1/4" x 3/8" x 3-31/32"	6.4 x 9.5 x 101	Birch Plywood Servo Rail
33325	1	3/8" x 1-5/8" x 7/8"	9.5 x 41.3 x 22.2	Maple Right Torque Block
33306	2	3/8" x 3/8" x 9-9/16"	9.5 x 9.5 x 243	Basswood Servo Rail Support
33303	2	1/2" x 1/2" x 12-25/32"	12.7 x 12.7 x 325	Wing Saddle Doublers
33308	1	3/8" Dia. x 23"	9.5 Dia. x 584	Birch Elevator Pushrod
33307	1	3/8" Dia. x 20-1/2"	9.5 Dia. x 521	Birch Rudder Pushrod
33300	1	1/8" x 1/2" x 2"	3.2 x 12.7 x 51	Tail Filler

Fuselage Hardware

A-121	2	Molded Nylon		Large Horns
M-125	2	Molded Nylon		Large Clevis
F-108	4	2-56 x 3/4" Machine Screws	2-56 x 19	Horn Screws
F-251	8	6-32 "T" Nut		"T" Nuts
F-125	1	4-40 x 1/2" Machine Screws	4-40 x 12.7	Hatch Screw
F-213	1	#4 Flat Washer		Hatch Screw Washer
F-250	1	4-40 "T" Nut		Hatch "T" Nut
F-152	4	#2 x 1/2" Sheet Metal Screws	#2 x 12.7	Main Landing Gear Screws
M-577	1	Molded Plastic		Motor Mount
F-138	4	6-32 x 1/2" Machine Screws	6-32 x 12.7	Nose Gear Screws
M-576	2	Molded Nylon		Nose Gear Blocks
M-578	1	Molded Nylon		Nose Gear Steering Arm
M-403	2	1/8" O.D. x 24"	3.2 O.D. x 610	Throttle/Nose Gear Pushrod Housing
F-214	8	#6 Flat Washer		Washers
F-137	4	6-32 x 1" Machine Screws	6-32 x 25.4	Mount Screws
F-267	4	6-32 x 3/4" Socket Head	6-32 x 19	Motor Screws
W-517	2	.047" x 19 7/8" Music Wire	1.2 x 505	Throttle/Nose Gear Pushrod
M-437	2	4-40 x 1/8" Machine Screw	4-40 x 3.2	E/Z Connector Screw
M-436	2	Brass Connector		E/Z Connector
M-419	1	Molded Nylon		Small Clevis
M-214	1	Threaded Brass Coupler		Solder Link
M-579	1	6-32 x 1/4" Socket Head	6-32 x 6.4	Steering Arm Screw
M-438	2	Molded Plastic		EZ Connector Washer
W-147	2	1/16" x 6" Wire Rod	1.5 x 152 Wire Rod	Elevator/Rudder Pushrod

Fuselage Continued

W-520	1	3/16" DIA. x 12-1/2"	4.7 Dia. x 318	Nose Gear Leg
W-518	1	3/16" DIA. x 13-1/4"	4.7 Dia. x 367	Left Landing Gear
W-519	1	3/16" DIA. x 13-1/4"	4.7 Dia. x 367	Right Landing Gear
M-383	2	3/8" x 12" Heat Shrink Tubing	9.5 x 305	Pushrod/Wing Dowel Shrink Tubing
M-210	2	1/16" x 10" Wire Rod	1.5 x 254 Wire Rod	Rudder and Elevator Pushrod

Fuselage Dies

Bag 3

33319 - 1 REQUIRED - 3mm x 4-27/32" x 25-27/32" (3mm x 123mm x 656mm) - MICRO-LITE PLYWOOD

Bag 3

33322 - 1 REQUIRED - 3mm x 4-27/32" x 25-27/32" (3mm x 123mm x 656mm) - MICRO-LITE PLYWOOD

Bag 5

33314 - 1 REQUIRED - 3mm x 4-27/32" x 25-27/32" (3mm x 123mm x 656mm) - MICRO-LITE PLYWOOD

Bag 3

33317 - 1 REQUIRED - 3mm x 4-27/32" x 25-27/32" (3mm x 123mm x 656mm) - MICRO-LITE PLYWOOD

Bag 3

33313 - 1 REQUIRED - 3mm x 4-27/32" x 31-27/32" (3mm x 123mm x 809mm) - MICRO-LITE PLYWOOD

Back

33315 - 1 REQUIRED - 3mm x 6-27/32" x 39-27/32" (3mm x 174mm x 1012mm) - MICRO-LITE PLYWOOD

Fuselage Dies Continued

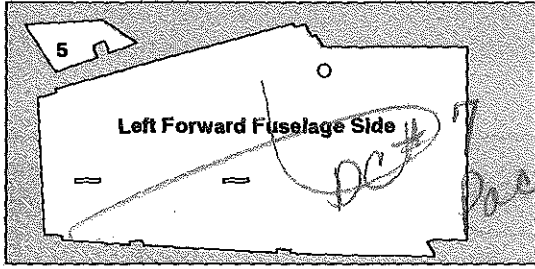

33320 - 1 REQUIRED - 3mm x 7-27/32" x 15-27/32"
(3mm x 199mm x 402mm) - MICRO-LITE PLYWOOD

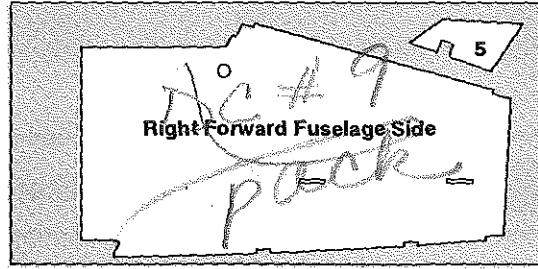

33318 - 1 REQUIRED - 3mm x 7-27/32" x 15-27/32"
(3mm x 199mm x 402mm) - MICRO-LITE PLYWOOD

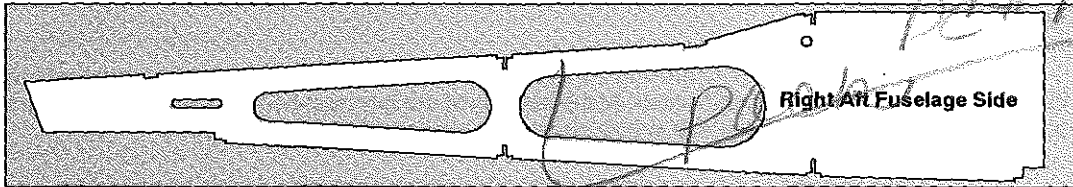

33321 - 1 REQUIRED - 3mm x 6-27/32" x 39-27/32" (3mm x 174mm x 1012mm) - MICRO-LITE PLYWOOD

Wing

Bag 4

33338	2	3/8" x 3/4" x 35-7/8"	9.5 x 10 x 91.1	Leading Edge
33340	1	1-3/8" x 1-3/4" x 11-15/32"	35 x 44.5 x 291	Left Wing Tip
33347	2	1/2" x 1-1/2" x 3-5/16"	12.7 x 38 x 84.1	Basswood Torque Rod Box
30532	4	3/32" x 1-7/8" x 35-7/8"	2.3 x 47.6 x 91.1	Trailing Edge Sheet
30639	32	3/32" x 1/4" x 6-7/8"	2.3 x 6.4 x 175	Cap Strips
33336	4	3/32" x 3-9/32" x 35-7/8"	2.3 x 83.3 x 91.1	Leading Edge Sheet
33337	2	3/8" x 3/8" x 35-7/8"	9.5 x 9.5 x 91.1	Trailing Edge
33342	1	1-3/8" x 1-3/4" x 11-15/32"	35 x 44.5 x 291	Right Wing Tip
33341	2	1/2" x 1-1/2" x 34"	12.7 x 38 x 86.4	Aileron
33344	20	3/32" x 3-5/32" x 1-5/16"	2.3 x 80.2 x 33.3	Shear Webs "G"
33345	10	3/32" x 2-7/8" x 9-7/8"	2.3 x 73 x 251	Center Section Sheet
33348	1	3/8" x 29/32" x 3-7/8"	9.5 x 18.3 x 98.4	Birch Plywood Wing Joinder
33351	4	3/8" x 3/8" x 35-7/8"	9.5 x 9.5 x 91.1	Spruce Spars
33346	4	1/2" Triangle x 2-1/8"	12.7 x 54	Wing Fairing
33349	2	1/4" x 3/8" x 1-1/2"	6.4 x 9.5 x 38	Birch Plywood Aileron Servo Rails
33350	4	3mm x 1-3/16" x 1-5/16"	3 x 30.2 x 33.3	Micro-Lite Plywood Shear Webs "B"

Wing Hardware

O-122	1	3" x 32"	76 x 813	Fiberglass Tape
M-210	2	1/16" x 10" Wire Rod	1.5 x 254 Wire Rod	Aileron Pushrods
M-980	2	6-32 Pre-bent Wire Rod		Aileron Torque Rod
M-377	2	Molded Nylon		Aileron Adjustment Fittings
M-125	2	Molded Nylon		Large Clevis

Wing Dies

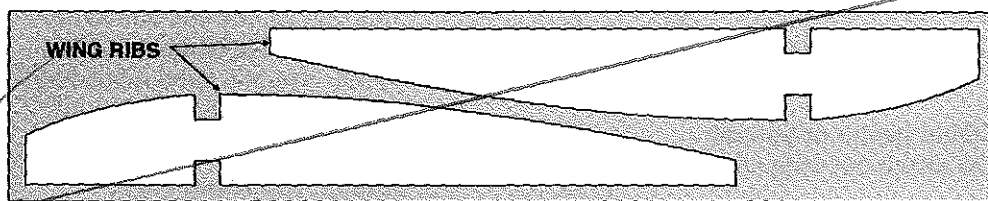

33343 - 13 REQUIRED - 3/32" x 2-7/8" x 14-7/8" (2.3mm x 73mm x 378mm) - Balsa

Miscellaneous

P-425	1	36" x 48"	914 x 1219	Plan Sheet 2
D-269	1	18" x 8-1/2"	457 x 216	Decal Sheet
D-270	1	18" x 8-1/2"	457 x 216	Decal Sheet
P-428	1	36" x 62"	914 x 1575	Plan Sheet 1 <i>fuse</i>
P-427	1	100 Pages		Instruction Manual

Before You Begin

The Aero-Star .60

The Aero-Star .60 is an R/C basic trainer that has been designed and engineered to offer the greatest possible assistance to someone who is both new to the hobby of building models and the sport of flying them.

This kit has been engineered to provide the greatest number of pre-cut parts, which is a great help to anyone not used to working with wood. At the same time the total number of parts has been kept to a minimum to provide a structure that is both strong and easily built.

The importance of building this model accurately, correctly and properly cannot be over stressed. A model that has **not** been built straight, correctly aligned and balanced, will **not** fly properly and will be difficult to control. Remember you are only going to build the model once. Hopefully, you will fly it for a long time. So, using a little extra care and attention while building it will pay off in a model that will give you many hours of enjoyable, trouble-free flying. Follow the instructions in this manual carefully. Install and operate the engine, radio and all accessories as per the manufacturer's instructions.

When properly built, balanced and flight trimmed; the Aero-Star .60 is positively stable in the air. This means that with 150 feet (45.7m) of altitude, neutralizing the controls and closing the throttle, the Aero-Star .60 will recover from **any** attitude and assume a normal glide. This self-saving feature will be a great help while you are learning to fly.

Although it is possible to learn to fly without any help, the odds of success are slim. Unlike R/C cars or boats, airplanes operate in a three dimensional environment and their control is a little more complex. We urge you to seek the help of an experienced, competent person to assist you with the initial flights. He should be able to check your model over to be certain that it is ready to fly and he should be able to take over if you lose control during the first flights. Joining an R/C Model Airplane Club is the best way to find help. Consult your local hobby dealer for a list of the clubs in your area. We also recommend, and most clubs require, that you join the Academy of Model Aeronautics. AMA membership will provide some insurance coverage, and will introduce you to a wealth of material that will help you to learn more about R/C models. The AMA can also provide you with a list of the clubs in your area.

Academy of Model Aeronautics
5151 East Memorial Drive
Muncie, IN 47302
(800) 435-9262

Getting Started

Tools and Materials You Will Need

You will need the following items to build this kit. Most of them are available from your local hobby dealer.

- Epoxy Glue -**
5 minute or 15 - 30 minute epoxy.
For special gluing applications.

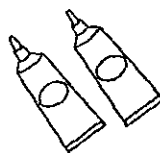

- Carpenter's Glue (white or yellow) -**
This is used to attach the wing sheeting.



- Building Board -**
This can be any flat, stiff material,
such as a pine board or a cork
board. You will need a building
board that is at least 18" X 48"
(457mm X 1219mm).

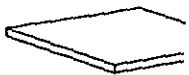

- X-Acto® Knife and Extra
Blades -**
This is a hobby knife with a small diameter han



- Instant Setting (thin) Cyanoacrylate (super-glue type) adhesive** - Used to instantly bond parts.

- Slow Setting (thick) Cyanoacrylate (super-glue type) adhesive** - used to glue parts that are to be moved for alignment.



Note: Cyanoacrylate adhesives are manufactured in many different formulations, some of which do not work well on models. Consult your local hobby dealer for the proper adhesive brands.

Warning: Cyanoacrylate adhesives cure (dry) very rapidly. Read all warnings and safety precautions on the label.

- #120 and #320 Grit Sandpaper, and #400 "Wet-or-Dry" Sandpaper** - The #120 and #320 grits are used for sanding and shaping parts. The #400 grit sandpaper is used to fine sand the finished model prior to applying the covering.

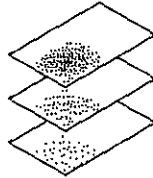

- Sanding Blocks** - These can be a piece of wood about 1/2" X 3" X 6" (12.7mm X 76mm X 152mm). Glue pieces of sandpaper to one side. These blocks will serve as excellent tools for sanding parts.

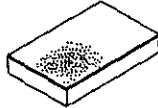

- Assorted Screwdrivers** -
- Pencil and Pen** - #2 or softer pencil and a Bic Flair felt tip pen.

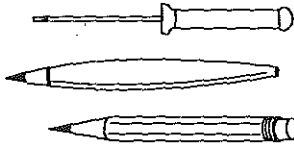

- Razor Saw** - Also called a Zona saw or back saw. Be sure the saw has fine teeth. Medium and coarse tooth saws will tear the woods.

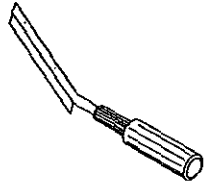

- 1/4" (6.3mm) Electric Drill and Drill Bits** - 1/32" (.8mm), 1/16" (1.5mm), 3/16" (4.7mm), 1/4" (6.4mm), and 5/32" (4.0mm).

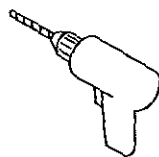

- 36" (914mm) and 12" (305mm) Steel Straight Edge** - Used to measure parts and as a guide for cutting straight lines.

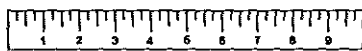

- 6-32 Tap and Tap Handle** - Used to cut threads into motor mount

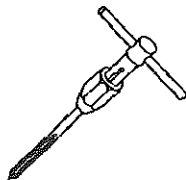

- Plastic Wrap** - Used to cover the plans and building board so that parts are not accidentally bonded to them.

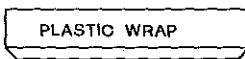

- Accelerator** - Used to speed up the drying time of the cyanoacrylate adhesives.



- Small Square** - Used to align parts at a 90° during construction.

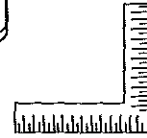

- Pins** - Used to secure parts to the building board during construction.



- Masking Tape** - Used for temporary assembly of fuselage.



- Tack Rag** - Used to wipe dust from the model before covering and painting.

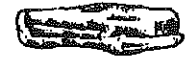

- Small Paint Brush** - One 1/4" (6.4mm) brush to paint inside cowl.

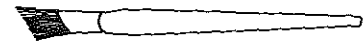

- Paper Towel** - For wiping glue, etc.

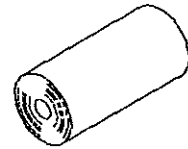

- Soldering Iron and Rosin Core Solder** - There is one part in this kit that needs to be soldered.

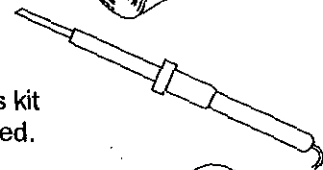

- Scissors** -



- Light Machine Oil, such as 3-in-1 Oil** - Used to lubricate parts and as a glue barrier.

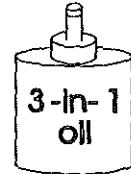

- Flat File** - Used to remove burrs and sharp edges from wire parts.

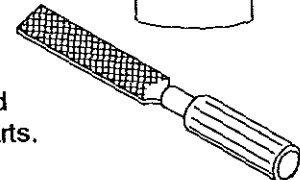

- Diagonal Cutting Pliers** - Used to cut wire.



- Needle Nose Pliers** - Used to cut and shape wire.



Additional Components

The following list of parts and components are required to complete the model and make it ready to fly. Because of variety, availability and personal preference, these items are left for the builder to select. All of these items are shown on the plans. Specific brands illustrate installation only and are not necessarily recommendations for these products.

- 1 - .45 to .61 two-cycle engine with muffler or 1 - .65 to .90 four-cycle engine with muffler -**
Take the Motor Mount that comes with the kit to the hobby shop when selecting an engine to be sure that the engine will fit the mount. Different brands of engines of the same size and displacement have different crankcase sizes, so not all engines will fit the same mount. If you are using a four-cycle engine, the Dave Brown 60FS is a four-cycle motor mount that will bolt directly onto the firewall. The prototype model used a Webra Silverline .61 with a Graupner 12-6 propeller.

Warning: Model engines produce a great deal of power for their size and are capable of inflicting serious injury. Observe all manufacturer's safety precautions and warnings. If you are not familiar with these products, get help from an experienced and competent person.

- Propellers -**
There is a large variety of propeller sizes and materials available. Follow the recommendations of the engine manufacturer and your hobby dealer in selecting propellers for your engine.

- 1 - 2-3/4" (70mm) Spinner -**
This is the nose cone that fits over the propeller and prop nut 2-3/4" (70mm) refers to the spinner diameter. A Carl Goldberg #159 Spinner was used on the prototype.

Note: Although the model can be flown without one, a spinner has definite safety advantages. If you do not intend using a spinner, we urge you to replace the prop nut, that holds the propeller to the engine, with an AMA safety nut. These devices will help reduce injury should you accidentally come into contact with the propeller while the engine is running.

- 1 - Four Channel Radio -**
"Channel" is a term that refers to the number of functions that a radio has. Typically, an aircraft radio's first four channels control the throttle, elevator, rudder and ailerons. There are radios available that have more channels; however, 4 channel radios are the most common and practical.

There are several different "modes" available. This refers to the assignment of channels to the controls on the transmitter. Mode 2 is the most widely used. However, you may prefer a different mode. Ask your hobby dealer to explain the different modes when you are deciding on a radio.

When buying a radio, bear in mind that there are many radio frequencies available. Not all of these frequencies can be used to operate model aircraft. Be sure to tell the dealer that you want a radio for use in a model "aircraft".

Warning: By Federal Communications Commission ruling, only a **select group** of these frequencies are **designated** for aircraft use. Under the law, it is **your responsibility** to use one of the proper frequencies for the type of model you are operating.

Note: There are radios available that use plug-in frequency modules. Although their cost is slightly higher than a fixed frequency radio, they will allow you to change frequencies should you decide to run an R/C boat or car.

Whenever possible, buy a radio that uses ni-cad rechargeable batteries as the power source. These batteries supply a more constant voltage than dry cells, which makes the radio much more reliable. Radios with rechargeable batteries come with the charger. The charging plugs are already installed.

Caution: Before turning on a transmitter, be certain that there are no other models in the area that are operating on the same frequency. Most 4 channel transmitters have a nominal line of sight range of three miles. If two transmitters on the same frequency are on at the same time the radio signals will interfere with each other, resulting in loss of control of the model that is in the air and a crash which could cause injury or property damage. It is your responsibility to operate your radio in a safe manner. Follow the recommendations of the manufacturer, your hobby dealer and the club members in your area.

12 oz. Fuel Tank -

There are many sizes, shapes and brands of fuel tanks available. It would be a good idea to take the plans to the hobby shop when selecting a fuel tank. That way, you will be able to lay the tank on the plan to see if it will fit in the fuselage. The prototype model used a Du-Bro #412 Fuel Tank.

3 Feet (914mm) of medium size Fuel Line -

Whenever possible, use silicon fuel line. It does not deteriorate and will not kink.

1 - 2-1/2" (63.5mm) Wheel and 2 - 2-3/4" (70mm) Wheels -

If you intend flying from asphalt or cement, be sure the wheels you buy are low-bounce wheels. The prototype model used Du-Bro #2.50T and #2.75T wheels.

6 - 3/16" (4.7mm) Wheel Collars -

These collars hold the wheels on the axles. The prototype model used Du-Bro #141 wheel collars.

14 Hinges -

There are several types of hinges available for model airplanes. We used Du-Bro #537 Kwik Hinges on our model. (See "Hinge Installation", under "Construction Tips", Page 11.)

1 Box #64 Rubber Bands -

Used to mount the wing on the fuselage. We recommend using Midwest Rubber Bands, part #1044.

Finishing Materials -

Although the model can be painted, we recommend that you finish it with Super Monokote. This is an iron-on covering that has a high gloss finish. If damaged, it can be repaired quickly and easily. You will need 3 six foot (18m) rolls of Super Monokote to cover your Aero-Star, not including trim colors. There are other finishing materials available. Your hobby dealer will be glad to explain them to you.

NOTE: If you decide to finish your Aero-Star with Monokote, you will also need a Monokote iron and heat gun.

1/2" x 7" x 11" (12.7mm x 178mm x 279mm) Foam Rubber -

This is used to protect the radio components from vibration. Du-Bro part #514 will work well for this application. If unavailable from your hobby dealer, it can be purchased at most general merchandise stores, such as K-Mart.

Construction Tips

How to Read the Plans

If this is your first model, the symbols and lines on the plans may be unfamiliar to you. This section will explain what the plans are and how to use them.

The plans are full-size drawings of the model that show the correct size, shape, and relationship of all of the parts. In order to show all of the parts "together", the plans are drawn using cutaway views, dashed lines and sections that allow you to "see through" some, or all, of the parts.

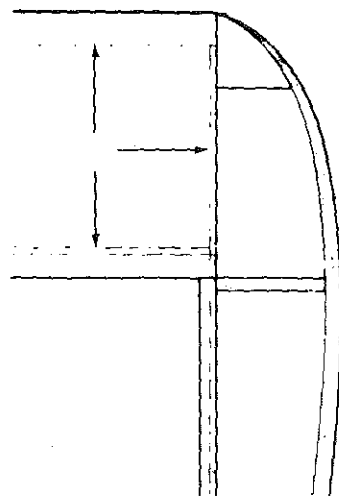

Dashed lines indicate a part, or portion of a part, that is underneath or inside of another part.

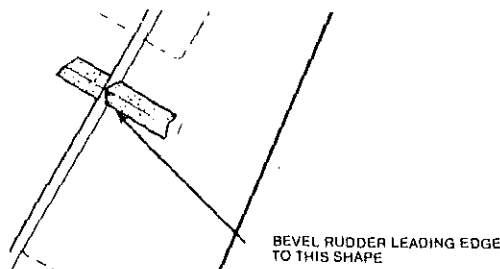

Parts that have shapes not apparent in one view are shown by sections.

The plans will be used in several ways. They will be helpful in identifying and positioning parts on other parts that are not built directly on the plan. Assemblies, such as the wings, will be built on the plans using the drawings as a pattern to locate parts. The plans will also be useful in positioning components, such as the radio, before installation in the model.

Cutting

All of the parts in this kit are pre-cut to size. Do not cut or shape any parts unless the instructions tell you to do so.

When cutting parts with your knife, make your first cut at a light pressure, being careful that the point of the knife goes exactly where you want it. Subsequent cuts should be made at moderate pressure until the part is cut out. Use a steel straight edge to guide the blade when cutting lines.

If, during construction, you notice the knife blade starting to tear the wood as you cut, the blade is dull. Replace it with a new blade. A sharp blade will make cutting easier and will enable you to work more accurately. If you are going to finish your Aero-Star with one of the iron-on covering materials, you will find that these materials will dull the knife blades very quickly, and it will be necessary to replace the blades often. Typically, you will use about four to six blades to cut and trim iron-on finishing materials for a model of this size.

Using Adhesives

Although water-based white glues can be used to assemble this kit, the Aero-Star has been designed to be built using cyanoacrylate adhesives; CA and Slow CA. These adhesives dry very rapidly. This will save you a lot of time and work by eliminating the need to pin, or tape, many parts together during construction.

There are several different brands of CA adhesives available from your hobby dealer that have been formulated specifically for use in model construction. Among these are Zap, Hot Stuff and Jet. These are all fine products and any of them will do the job.

The following general uses apply to all CA adhesives. However, there are slight differences in the way each brand is used. Read and follow the specific instructions for the brand you are going to use. Also, read and follow all warnings and cautions on these products. If used improperly, they can be dangerous.

When using CA adhesives, place the parts to be bonded into contact and then run the CA into the joint. In order for these adhesives to bond, there should not be any gaps in the joint between the parts. The bond will be instantaneous, so be certain that the parts are positioned exactly as you want them.

Slow CA is a thick form of CA. It has the ability to bridge gaps between parts. It also cures at a slower rate. Generally, it is to be used where parts must be moved around during gluing, where parts are too large to be held in the desired position, or where the gluing surface is too large to apply CA to the joint. In use, Slow CA is applied to one of the parts, and then the two parts are joined.

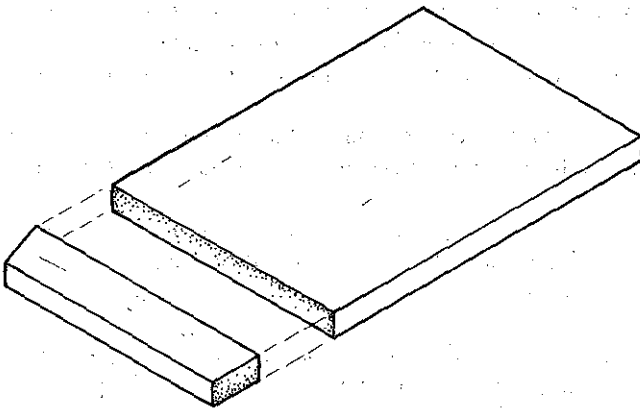

Note: Some brands of Slow CA will soak into the end grain of wood parts, resulting in a weak joint. To prevent this, apply Slow CA to the end grain of the part and allow it to cure. This will seal the wood grain. Apply a second coat of Slow CA to the part and then joint the two parts. This is called "pre-gluing". Test the Slow CA that you will use on some scrap wood to see if pre-gluing is necessary for that brand. The instructions will tell you in every step which kind of adhesive to use.

Note: Most CA manufacturers have a product available that is known by the generic name, debonder. This is a solution that will dissolve CA and Slow CA adhesives. It is very useful for separating parts that are not constructed properly, and for removing CA adhesives that come in contact with your skin or tools. Although debonder isn't necessary to build this model, you may want to have it available during construction.

Hinge Installation

The control surfaces of the Aero-Star pivot on plastic hinges. Depending on the brand and kind of hinges you purchase, they may, or may not come with installation instructions. For this reason, the following general procedures are provided.

Our R & D staff prefer to use the Du-Bro Kwik Hinges, a CA hinge, because of their durability and ease of use. For this reason, these instructions show how to install CA hinges.

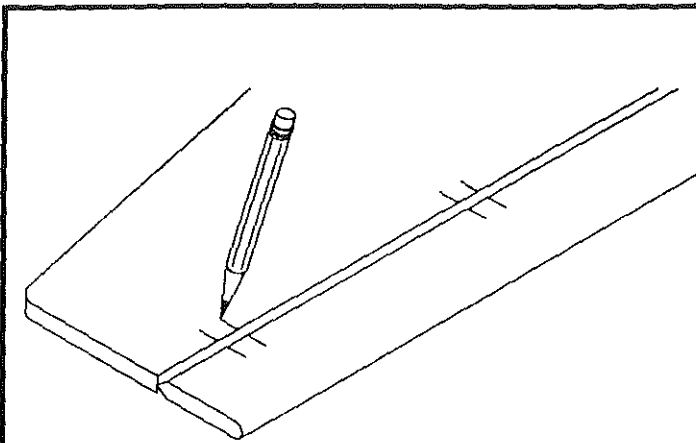

Place the ailerons, elevator and rudder on the plan and mark the locations of the hinges. Lay the parts in the appropriate position and transfer the marks to the wing, stabilizer and fin.

WARNING: You will need to be extremely careful when cutting the hinge slots with your knife blade. If you would slip the blade could give you a serious cut before you knew it. It is a good idea to wear some type of protective glove, such as leather, when finishing these steps.

Once you have marked the positions of the hinges, you will need to mark centerlines on the parts, where the hinge slots will be cut. Follow the steps below for cutting the hinge slots with your knife blade.

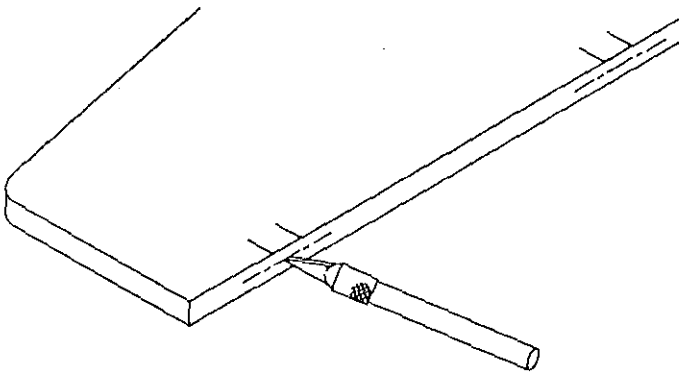

1. First, cut a shallow slit along the centerline of the hinge location. This initial cut is to establish your cut in the proper location. Concentrate on the centerline and don't cut too deep.
2. Make a few more cuts in the same location, getting slightly deeper each time. As you make these cuts, be sure that the blade goes straight into the wood. Repeat this step until the slot is deep enough for the hinge.
3. Test fit each hinge in the slots. If the hinge doesn't want to go all the way into the slot, you may need to slide the knife blade into the slot a few more times to open it up.

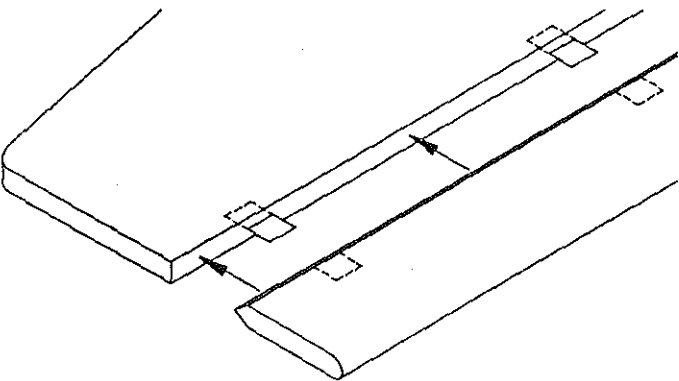

Insert the hinges in all of the parts and test fit the ailerons, elevator and rudder on the plane. **Do not glue the hinges yet. They will be glued in place after the model has been covered.**

Once the model has been finished and completely covered, you can use the following steps to secure the hinges to the plane.

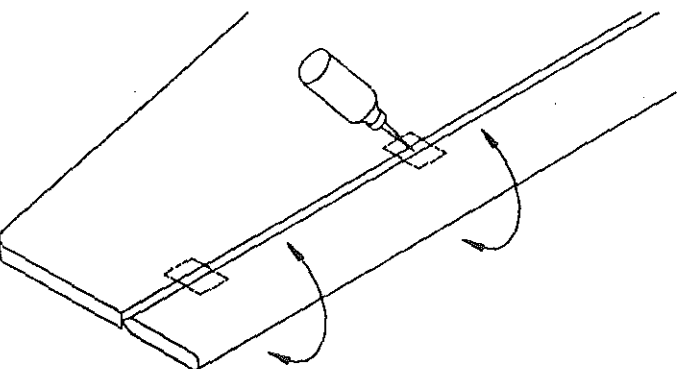

1. Insert the hinges in the rudder. Connect the rudder to the fin, making sure that it is positioned properly, as shown on the plan.
2. Pull the rudder back so that there is a 1/64" (.4mm) gap approximately the thickness of 4 pieces of paper, between the rudder and fin.
3. Move the rudder to make sure that it will turn without binding.
4. With great care, apply 4 to 6 drops of CA to the center of each hinge. The surface of the hinge will allow the glue to wick into the slot and create a strong bond.
5. Wipe away any excess CA with a piece of paper towel. After the glue has cured the rudder may seem a bit stiff. Working it back and forth will loosen it up.

Repeat these steps to secure the ailerons and elevator to the wing and stabilizer.

Assembly Instructions

This manual divides construction of the Aero-Star into sections; Tail Section, Fuselage, etc. Within each section, construction is further broken down into sub-assemblies; Stabilizer and Elevator, Fin and Rudder, etc. There is a description of the parts to be used in each assembly at the start of that sub-assembly.

Where necessary, general instructions and comments appear at the start of each sub-assembly. Explanations that clarify individual instructions appear as notes following the instruction. Read through each sub-assembly and identify all of the parts before starting construction on a sub-assembly.

Remember, your Aero-Star will fly only as well as it is built. Build each sub-assembly accurately; according to the plans and instructions. Be sure that all parts are aligned correctly and that you use the proper adhesive for each assembly. The instructions will tell you which adhesive to use.

Most of the wood parts for each sub-assembly are packed in numbered plastic bags. In some bags, not all of the parts will be used at once. Parts not used should be put back in the proper bag. They will be used later in construction.

All hardware items are packed in two plastic bags; one with the Fuselage hardware and one with the hardware for the Wing. Various parts from these two bags will be used at different points during construction. To avoid losing these small parts and screws, they should be kept in these bags until needed.

Check-off boxes (☐) appear next to each instruction throughout the text to help you keep track of your progress.

Some of the sections in this manual do not have check-off boxes. These explain general procedures, rather than specific instructions.

Tail Section

The Tail section consists of the Stabilizer, Elevator, Fin, and Rudder. These surfaces control the model's ability to climb, dive and turn. They must be assembled so that they are flat, with no twists or warps.

Stabilizer and Elevator

You will need the parts illustrated below to complete this sub-assembly. They are all packed in Bag Number One (#1).

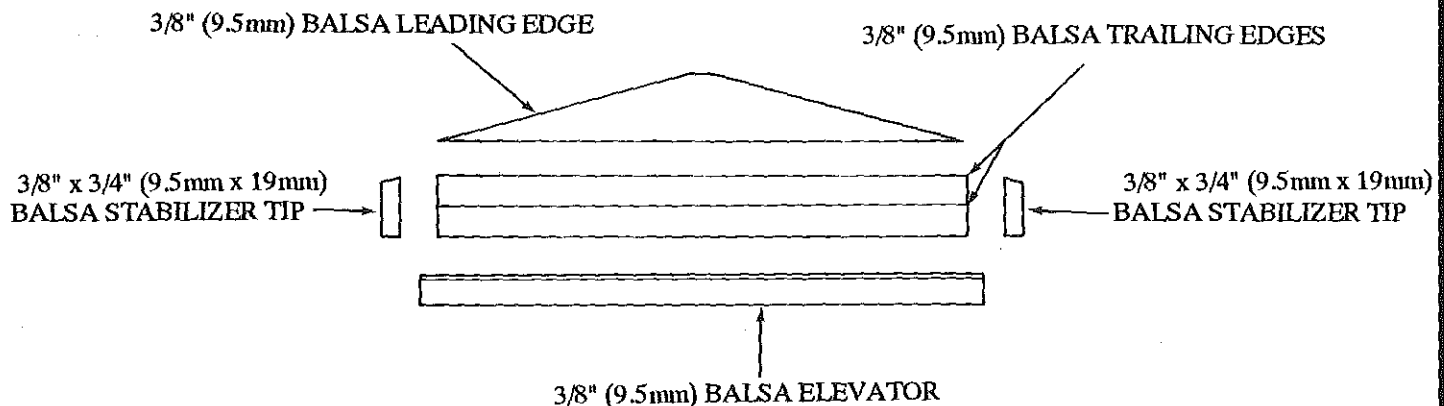

You will also need 5 hinges, not supplied with the kit, to complete this sub-assembly.

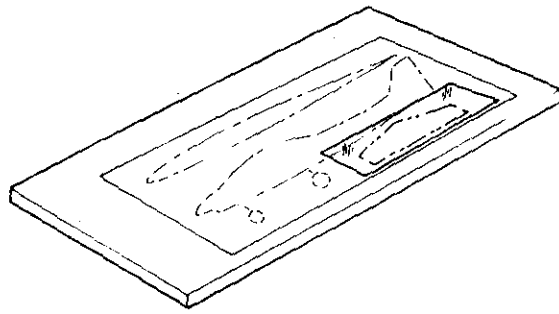

- 1. Lay the Fuselage plan on your building board and cover the drawing of the stabilizer with plastic wrap.

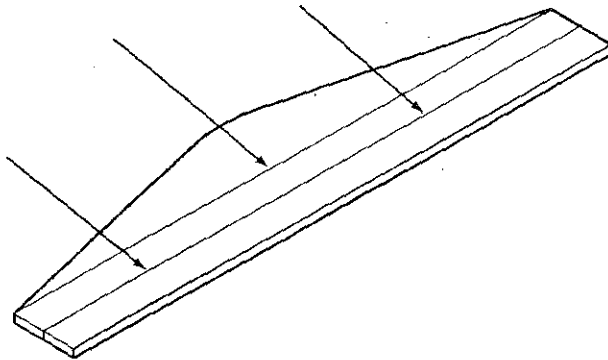

- 2. Lay the stabilizer leading and trailing edge parts on the drawing of these parts on the plan. Press them together. If there are any gaps in the joint between the parts, remove the gap by sanding the mating edge of one of the parts with a sanding block until the joint is tight.

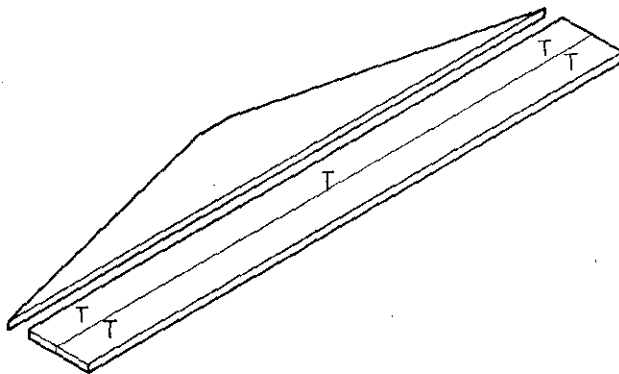

- 3. Align the Stabilizer trailing edge pieces over the drawing of the trailing edge on the plan and pin one to the building board with t-pins.
- 4. Apply slow CA to the edge of the loose trailing edge. Lay this part flat on the board. Align it with the trailing edge pinned down and press the two parts together. The slow CA will cure in about 30 seconds. Repeat this step to glue the leading edge to the trailing edge.

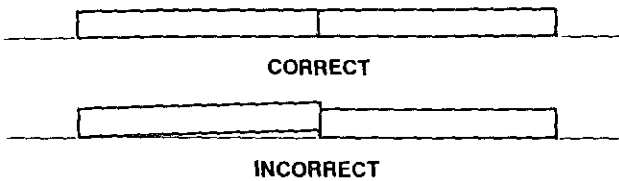

Note: When pressing the Stabilizer parts together, be sure that both parts are flat on the board so that the edges are flush, as shown.

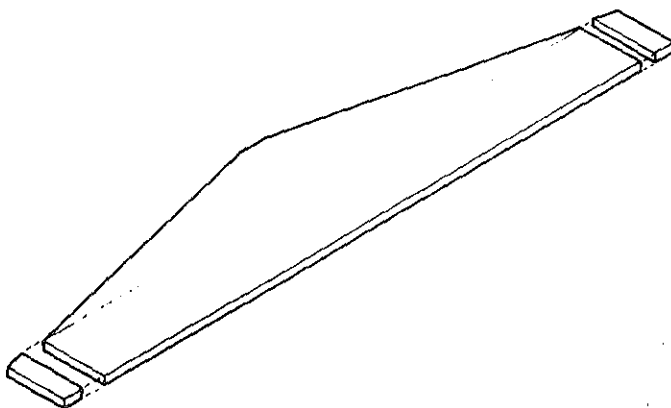

- 5. Using the Stabilizer drawing as a guide, glue the Stabilizer tips to the stabilizer trailing edge with slow CA. Again, be sure that the parts are flat on the board before pressing them together.

Note: The edges of the Stabilizer trailing edge that contact the tips have end wood grain. If you are using a brand of Slow CA that soaks into the grain, be sure to pre-glue the end grain as described in "Using Adhesives", page #11.

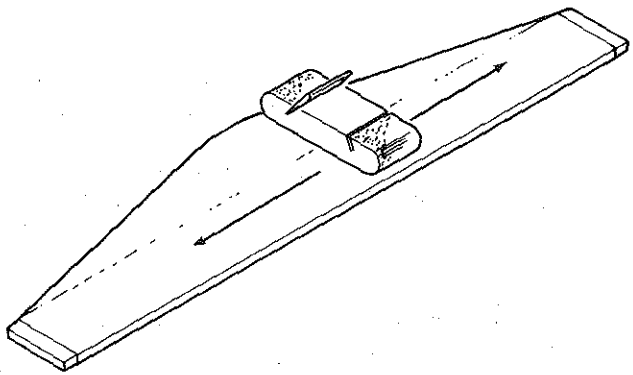

- 6. Remove the completed Stabilizer from the plan. Lay it flat on the building board and lightly sand the joints on both sides with a sanding block to remove any raised edges.

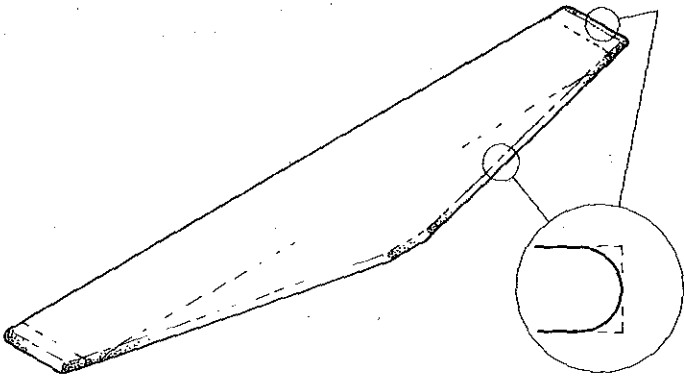

- 7. Using a sanding block, sand the leading edges and the tips of the Stabilizer to a round section, as shown.

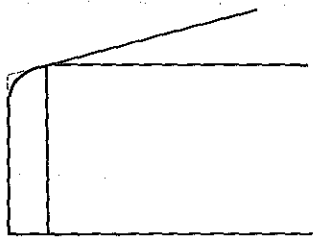

- 8. Using a sanding block, sand a curve in the corners of the Stabilizer tips to match the drawing of the Stabilizer on the plan. Then, using a piece of #80 grit sandpaper, sand the curves to a round section to blend with the rounded leading edges and tips.

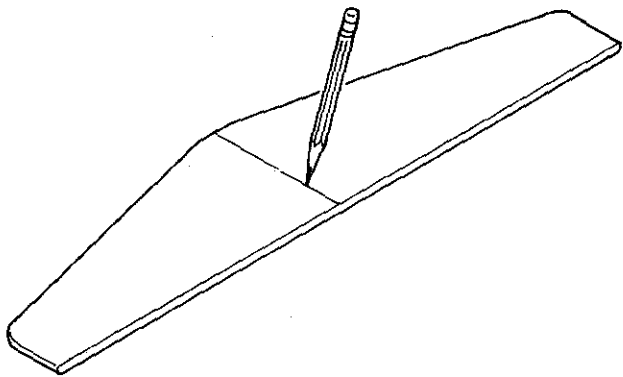

- 9. Align the Stabilizer on the drawing of the Stabilizer on the plan. Using a straight edge, lightly mark the centerline on the Stabilizer with a pencil.

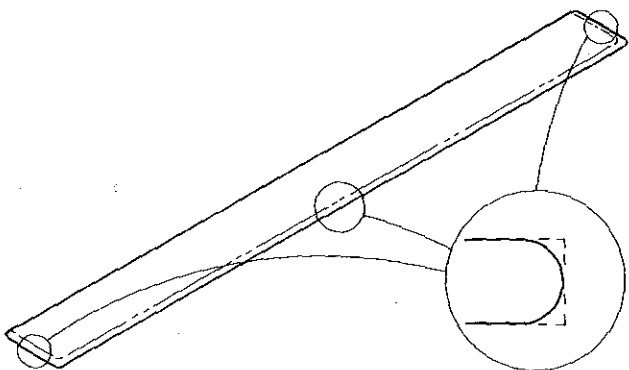

- 10. Remove the Elevator from the bag. Using a sanding block, sand the tips and trailing edge of the Elevator to a round section.

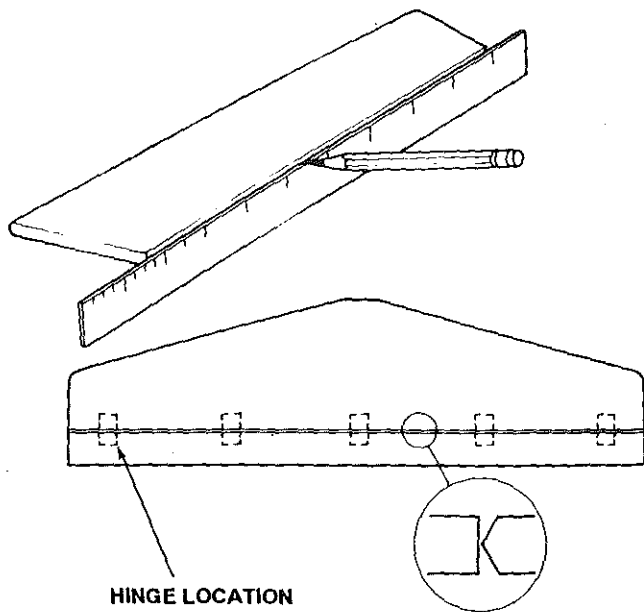

- 11. Mark a centerline on the leading edge of the Elevator. Using a sanding block, sand a bevel into the leading edge, as shown. Align the Elevator with the Stabilizer so that the beveled edge of the Elevator contacts the trailing edge of the Stabilizer. If necessary, sand the tips of the Stabilizer, or Elevator, until the tips of both parts are flush, as shown.
- 12. Mark the hinge locations, shown on the plan, on the Stabilizer and Elevator with a pencil. Following the instructions for the brand of hinges that you are using, install the hinges in the Elevator and Stabilizer at the location shown on the plan. Do not glue the hinges to these parts yet. (See "Hinge Installation", Page #12.)

Note: The hinges for all of the control surfaces will be glued after the model is finished. By doing this, it is much easier to cover and finish the model.

The Stabilizer and Elevator are now complete. They will not be needed again until the fuselage is built. Place them aside where they won't be damaged.

Fin and Rudder

You will need the parts illustrated below to complete this sub-assembly. They are all packed in Bag Number Two (#2).

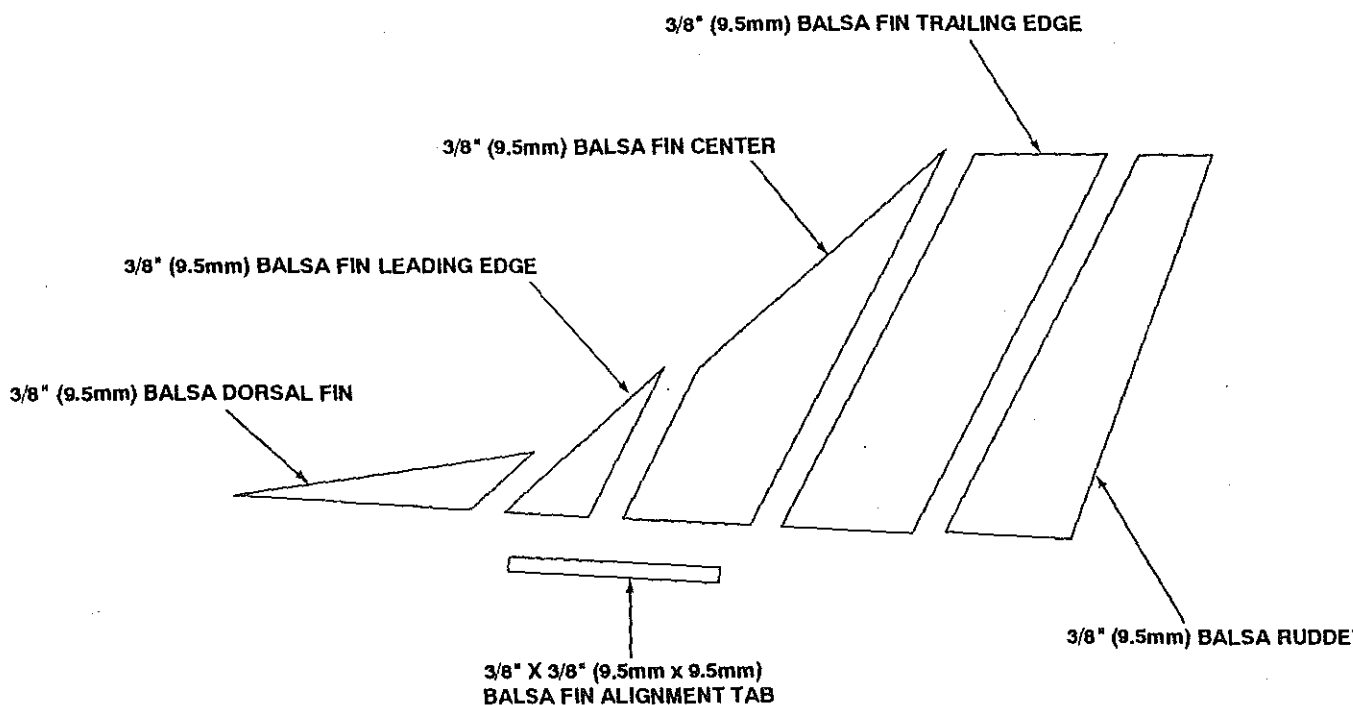

You will also need 3 hinges, not supplied with the kit, to complete this sub-assembly.

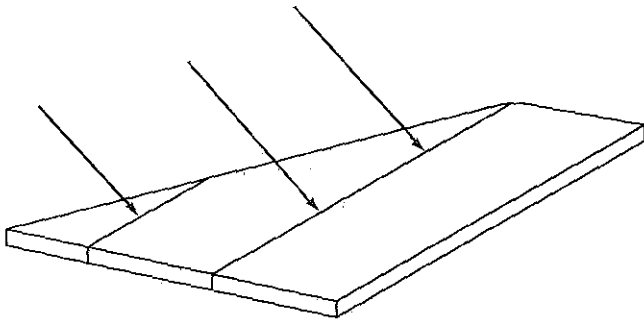

- 13. Cover the drawing of the Fin, on the plan, with plastic wrap.
- 14. Position the three Fin pieces shown over the drawings of these parts on the plan and, if necessary, sand the joints for a tight fit.

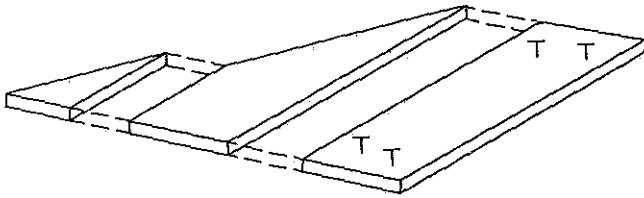

- 15. Align the Fin trailing edge over the drawing of the Fin trailing edge on the plan and pin it to the building board with t-pins.
- 16. Apply Slow CA to the Fin center piece. Lay the the Fin center flat on the plan, align the two parts and press them together. Repeat this step to glue the Fin leading edge to the Fin.

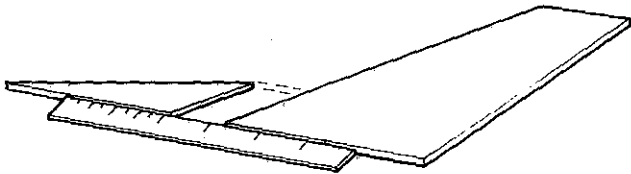

- 17. Press the Dorsal Fin into position against the leading edge of the Fin. If necessary, sand the rear edge of the Dorsal Fin to align it with the drawing when it is in contact with the Fin. When satisfied with the fit, glue it to the Fin with Slow CA. If necessary, pre-glue the end grain on the Dorsal Fin.

Note: It would be helpful to butt a straight edge against the bottom of the Fin parts while fitting the Dorsal Fin, as shown. This will insure that the bottom of the Dorsal Fin is straight, relative to the bottom of the other Fin parts.

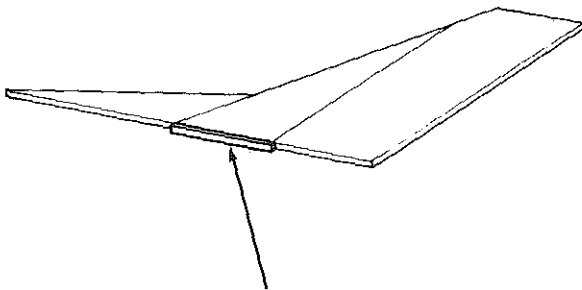

- 18. Apply Slow CA to the Fin alignment tab and bond it to the bottom edge of the Fin, at the position shown on the plan.

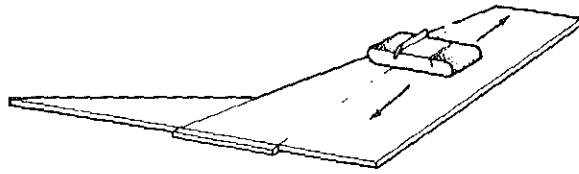

19. Remove the completed Fin from the plan. Lay it flat on the building board and lightly sand the joints on both sides with a sanding block to remove any raised edges.

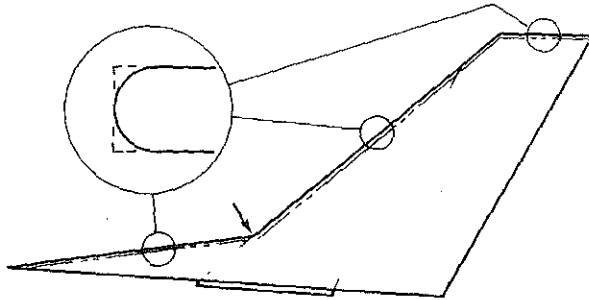

20. Using a sanding block, sand the leading edges of the Dorsal Fin and Fin to a round section, as shown. When sanding the corner of the Dorsal Fin, where it meets the Fin, use short back and forth movements of the sanding block to avoid removing too much wood.

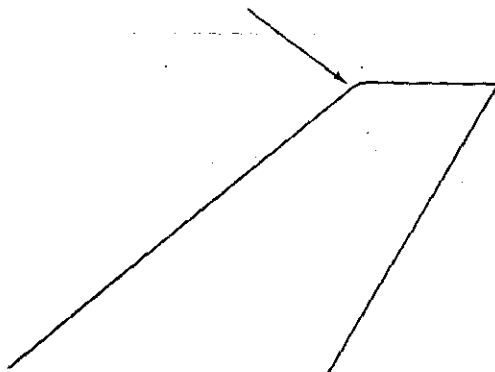

21. Using a sanding block, sand a curve on the corner of the Fin to match the drawing of the Fin on the plan. Then, using #80 grit sandpaper, sand the edge of the curve to blend with the rounded leading edge of the Fin.

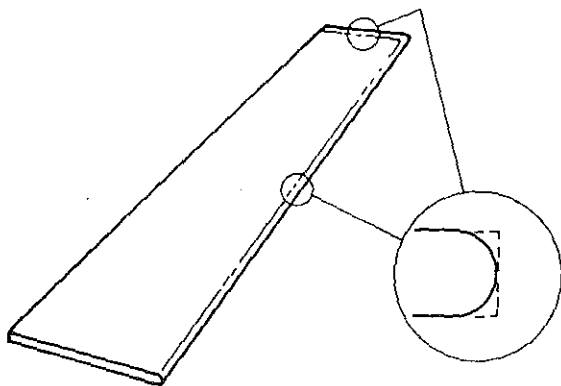

22. Remove the pre-cut Rudder from the bag. Sand the leading and trailing edge of the Rudder to a round section as shown.

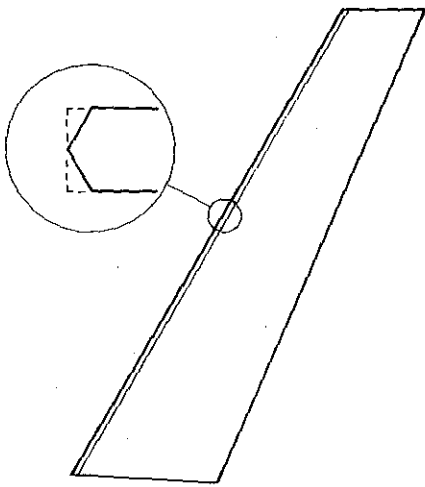
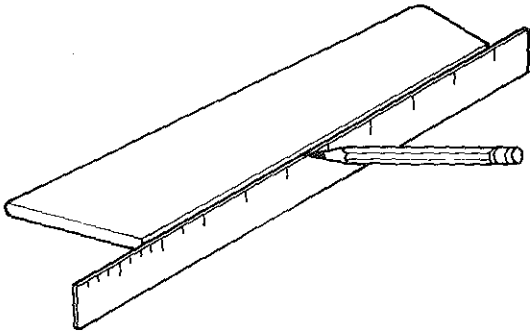

- 23. Using a ruler, lightly mark a centerline on the leading edge of the Rudder. Then, using a sanding block, bevel the leading edge, as shown, so that the point of the bevel is on the pencil line.

- 24. Press the beveled edge of the Rudder against the trailing edge of the Fin, aligning it with the drawing and the top of the Fin. If necessary, sand the top of the Rudder flush with the top of the Fin. Check to be sure that the bottom of the rudder is shorter than the bottom of the Fin. This gap is necessary so that the Rudder will clear the Fuselage when it moves.

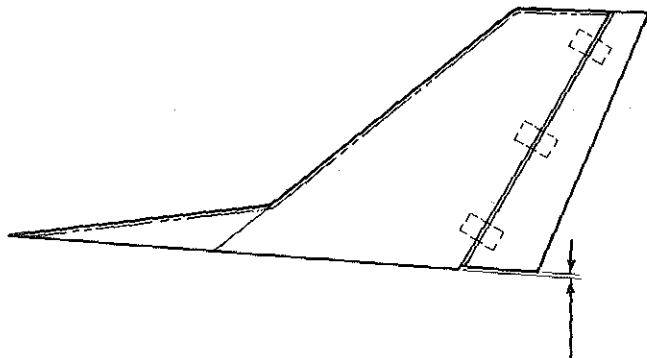

- 25. Mark the hinge locations, shown on the plan, on the Fin and Rudder with a pencil. Following the instructions for the brand of hinges that you are using, install the hinges in the Fin and Rudder at the locations shown on the plan. However, do not glue the hinges to these parts yet. (See "Hinge Installation", Page #12.)

The Fin and Rudder are now complete. They will not be needed again until the Fuselage is built. Place them aside where they won't be damaged.

About the Fuselage

Most of the Fuselage parts are made from Micro-Lite[®] plywood. This wood is very strong for its weight, however, CA and Slow CA adhesives take longer to cure on this type of wood than they do on Balsa. For this reason, it will be necessary to use accelerator along with the CA during construction. The instructions will tell you when, and how, to use the accelerator.

The Aero-Star's Fuselage is constructed from interlocking die-cut parts that self-align during construction; insuring that the Fuselage will be straight. Because the parts interlock, it is important that the construction sequence and gluing instructions be followed carefully. Before starting construction, read through the Fuselage assembly instructions to be sure you understand how all of the parts fit together, and to identify all of the parts. During construction, use the check-off boxes to keep track of your progress.

Fuselage Construction

For this sub-assembly, you will need the parts illustrated and listed in the Fuselage section under "Kit Contents", pages 3-5. The Fuselage Sides are packed in the kit box. All of the other parts are packed in Bag Number Three (#3).

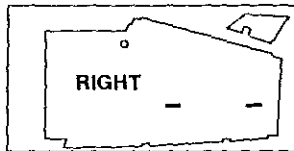
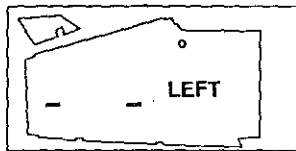

26. Carefully remove the die-cut sheets of Micro-Lite[®] plywood from bag number three (#3). Using the illustrations in the front of the book, **lightly** mark the part numbers on all of the die-cut parts with a pencil **before** removing them from the die-cut sheets.

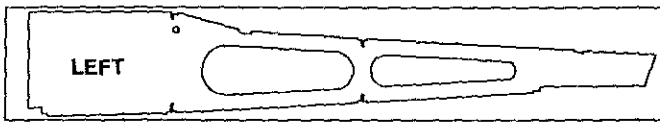

Note: Later in construction, the part numbers will be used to identify each part. The parts will not be installed in numerical sequence.

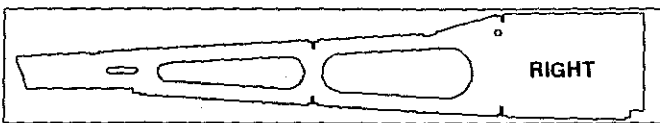

27. Remove the Fuselage Sides from the die-cut sheets. Write the words LEFT or RIGHT, as appropriate, on the inboard face of each Fuselage Side.

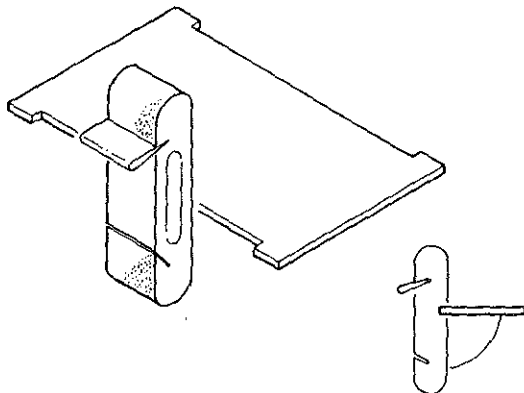

28. Using a sanding block, **very lightly** sand the edges of the die-cut parts to remove any burrs or rough spots. Hold the sanding block at a 90° angle while doing this.

Note: Smoothing the edges of the parts in this manner will help the CA in bonding the parts together. Remember, you only want to **smooth** the edges of the parts, **only** removing the burrs.

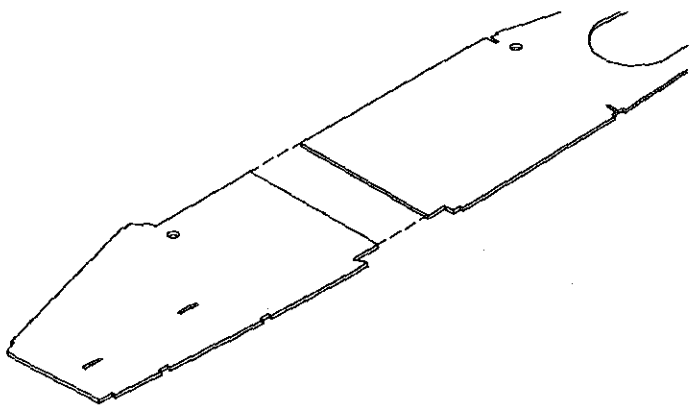

29. Cover the Fuselage plan with plastic wrap. Lay a forward and aft section of the Fuselage Side on top of the plan and butt the edges together, aligning the top and bottom. If necessary, sand the edges for a good fit. Glue the joint with slow CA.

Note: Make sure that the parts line up with the Fuselage drawing on the plan as much as possible. The Fuselage Sides need to be glued straight to build a fuselage that is straight.

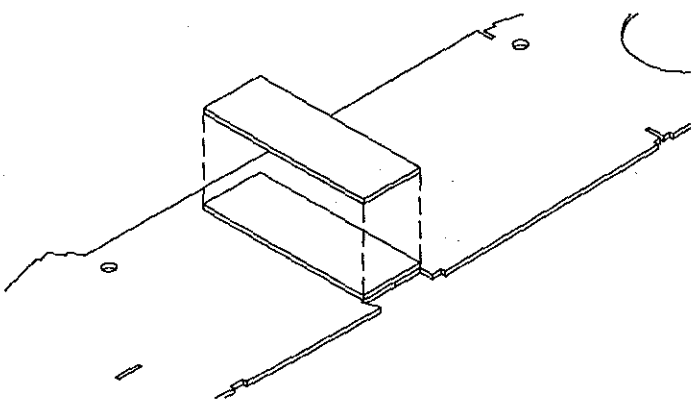

30. Apply Slow CA to one side of a Fuselage Doubler and set it in place on the inside surface of the Fuselage side. Center the Doubler over the joint and flush with the bottom of the Gear Block Opening, as shown.
31. Repeat instructions #29 and #30 to assemble the opposite Fuselage Side. Make sure that the second doubler is also glued to the inside surface of the Fuselage Side, giving you a left and right part.

1/4" (6.4mm)

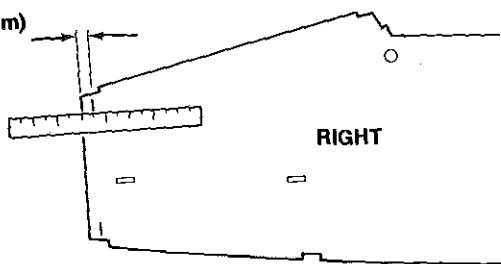

32. Using a ruler, measure in 1/4" (6.4mm) from the top and bottom of the front edge of each Fuselage Side. Mark these locations with a sharp pencil, as shown. Be sure that these marks are made on the same side as the words RIGHT or LEFT on each Fuselage Side.

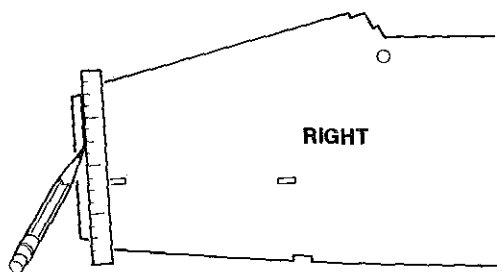

33. Lay a straight edge on the pencil marks and, using a pencil with a sharp point, draw a line across each Fuselage Side, as shown.

Note: After drawing the pencil lines, check again to be sure they are 1/4" (6.4mm) in from the front edge of each Fuselage Side. These lines will be used to position the bracing for the Firewall. If they are not accurately drawn, the Firewall will not fit properly.

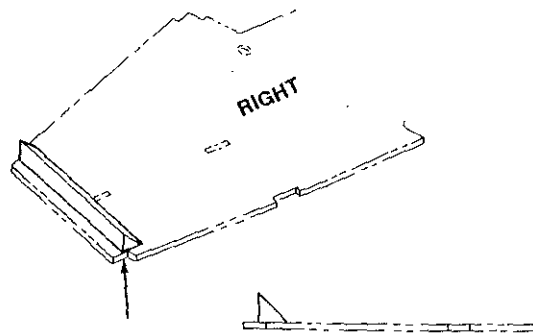

- 34. Remove the two pieces of 3/8" (9.5mm) balsa triangle stock from bag three (#3). Apply slow CA to one piece and align it on the pencil line so that the 90° edge is centered between the top and bottom of the Fuselage Side, shown. Bond the remaining piece of triangle stock to the other Fuselage Side in the same manner.

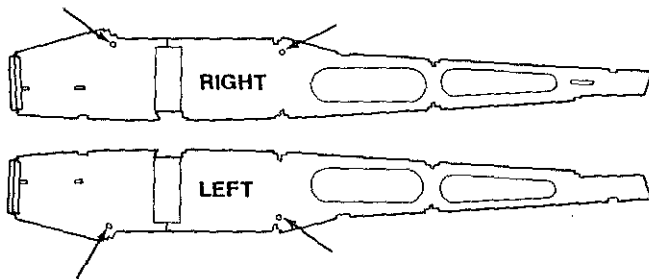

- 35. Spray accelerator around the round holes on both Fuselage Sides, as shown. Be sure this is done on the same side as the wording on each Fuselage Side.

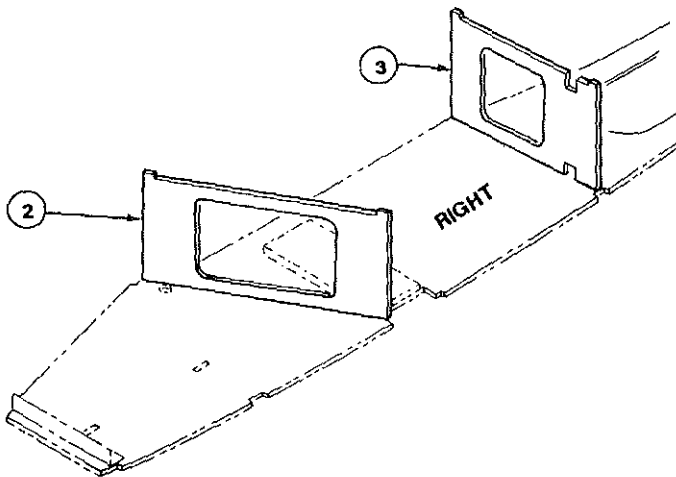

- 36. Study the Fuselage plan and the following illustration to determine the correct positions for parts two (2) and three (3). Test fit the tabs on these parts in their slots on the Fuselage Sides. Do not glue them in place at this time. They will be used to position parts five (5) and (6) in instructions #37 and #39.

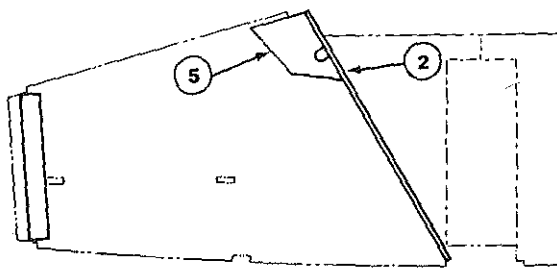

- 37. Apply Slow CA to one side of one part five (5). Hold part two (2) in position on the Fuselage Side, at a 9° angle. Position part five (5) so that its slot is aligned over the hole in the Fuselage and it just contacts part (2). Then, remove part two (2) and press part five (5) into contact with the Fuselage Side.
- 38. Repeat instruction #37 to install part five (5) on the opposite Fuselage Side.

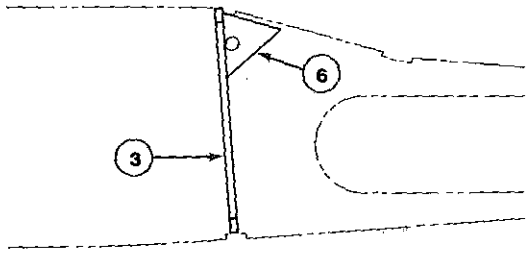

- 39. Apply Slow CA to one side of one part six (6). Hold part three (3) in position on the Fuselage Side, at a 90° angle. Position part six (6) so that its slot is aligned over the hole in the Fuselage and it just touches part three (3). Then remove part three (3) and press part six (6) into contact with the Fuselage Side.
- 40. Repeat instruction #39 to install part six (6) on the opposite Fuselage Side.

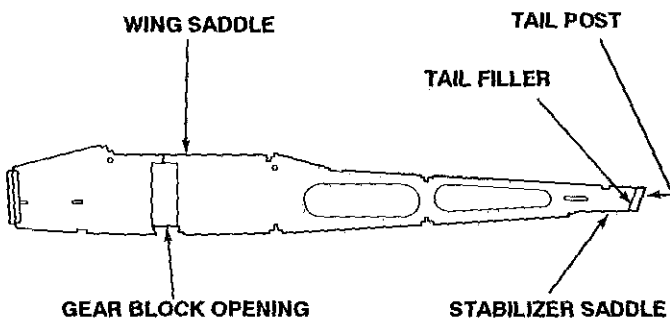

Note: Before going on, it will be helpful to become familiar with some of the terms that will be used in the following instructions. Study the illustration at the left, and the Fuselage Sides, so you can identify the various areas described by the terms on the illustration.

- 41. Position the 1/8" x 1/2" x 2" (3.2mm x 12.7mm x 51mm) Tail Filler flush with the tail post of the right Fuselage Side and glue in place with CA.

Note: In the following instructions, the Fuselage parts will be taped together. Do not glue any parts until told to do so.

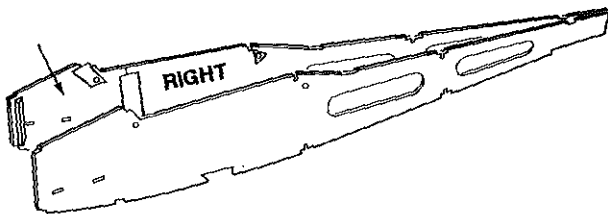

- 42. Place the Fuselage Sides together so that the wording on each side face each other.

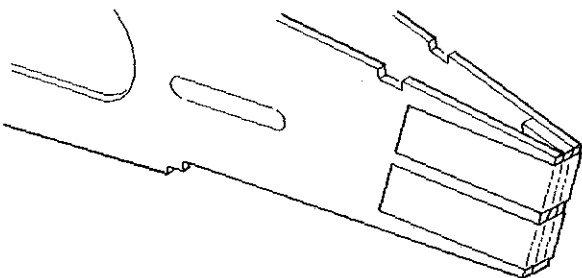

- 43. Align the Fuselage Sides at the Tailpost and wrap two pieces of masking tape across the Tailpost, as shown.

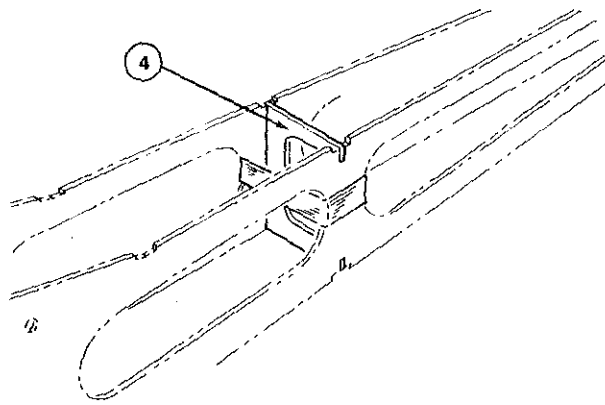

- 44. Insert the tabs on part four (4) into the slots in the Fuselage Sides. Wrap masking tape through the Fuselage, as shown, to secure part four (4).

Note: Part four (4) is symmetrical. Either end can be placed at the top of the Fuselage.

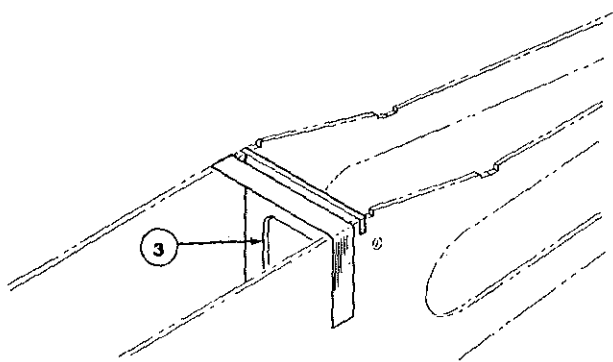

- 45. Insert the tabs on part three (3) into the slots in the Fuselage Sides with the rectangular notches on the bottom. Secure part three (3) with a piece of masking tape pulled across the back of the Wing Saddle.

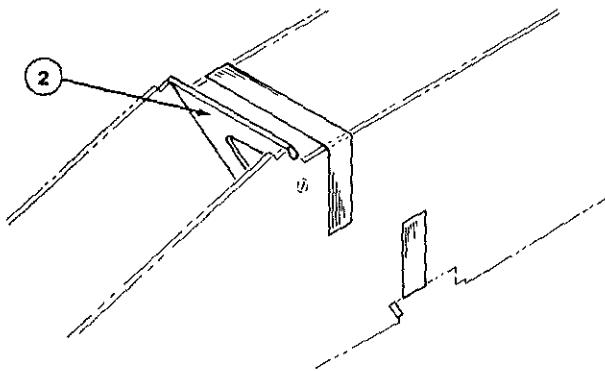

- 46. Insert the tabs on part two (2) into the slots at the front of the Wing Saddle and the slots in front of the Gear Block Opening, as shown. Install part two (2) with the wide end towards the top of the Fuselage. Secure with two (2) pieces of masking tape stretched across the front of the Wing Saddle and across the Gear Block Opening.

Note: If any of the tabs on the following parts do not slip into their slots in the Fuselage, trim the edge of the tabs with an X-Acto[®] knife. Do not force the tabs into the slots, as this could cause the wood to break.

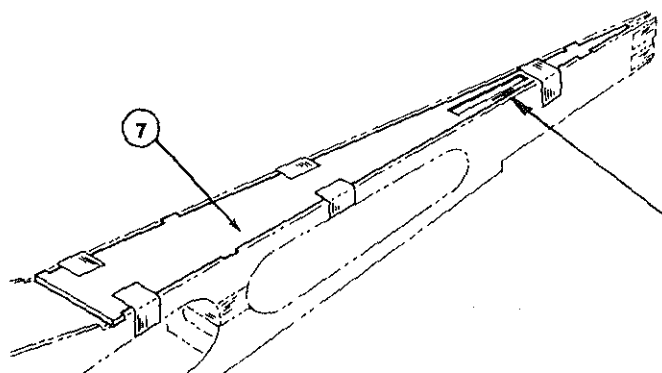

- 47. Insert part seven (7) between the Fuselage Sides. Be sure that the indented Pushrod slot, next to the Rudder slot, is on the left side. Secure part seven (7) with sh pieces of masking tape, as shown. Use only enough to hold the part in position.

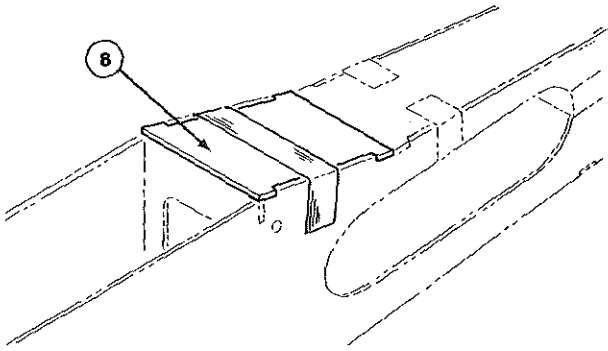

- 48. Insert part eight (8) between the Fuselage Sides and secure it with a piece of masking tape pulled across the Fuselage, as shown.

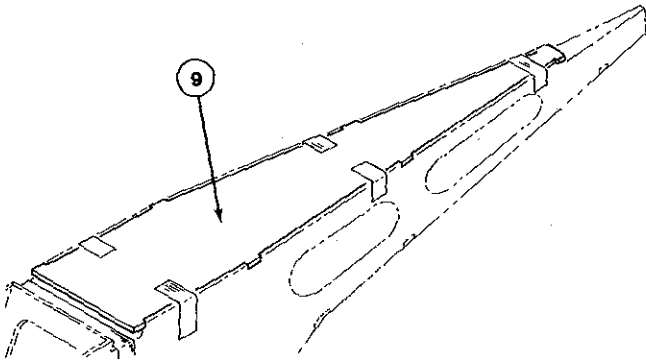

- 49. Insert part nine (9) between the Fuselage Sides. Secure it with short pieces of masking tape, as shown.

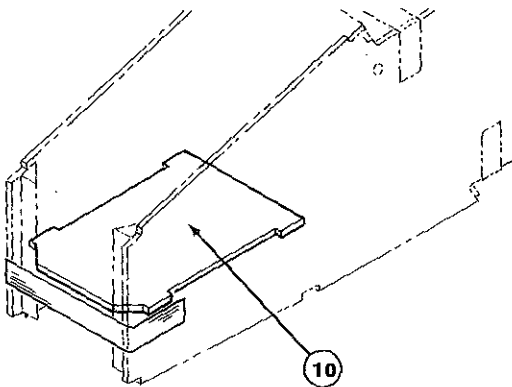

- 50. Insert the tabs on part ten (10) into the rectangular slots in the Fuselage Sides. Secure part ten (10) with a piece of masking tape pulled across the front of the Fuselage, as shown.

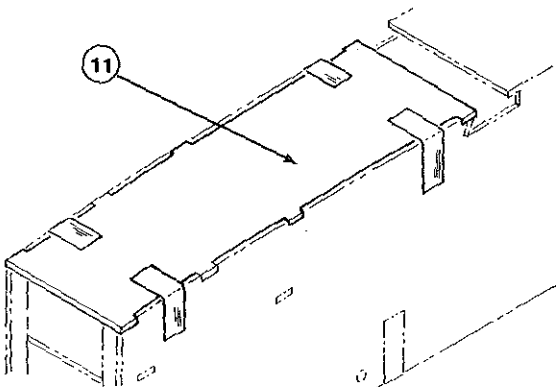

- 51. Insert part eleven (11) between the Fuselage Sides and secure it with short pieces of masking tape.

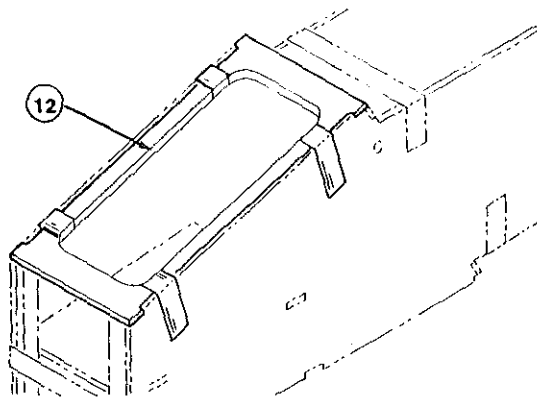

- 52. Insert part twelve (12) between the Fuselage Sides and secure it with short pieces of masking tape. Remove the hatch from part twelve (12) temporarily.

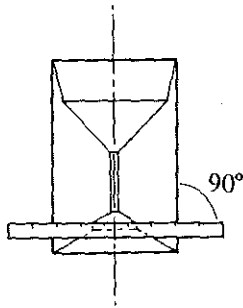

CORRECT

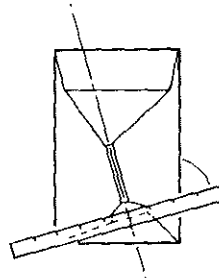

INCORRECT

- 53. Look down the Fuselage from the rear, as shown. Check that the alignment of the Tailpost is parallel to the Fuselage Sides. If not correctly aligned, loosen the tape on the Tailpost, twist it into position, and re-attach the tape.

Also, check that the Stabilizer Saddle is aligned 90° to the Fuselage Sides by holding a straight edge against the Saddle, as shown.

Important Using Accelerator With CA Adhesives

CA adhesives generally do not bond rapidly to Micro-Lite[®] plywood. By using accelerator, the CA adhesive will be forced to cure instantly, creating a solid joint between parts.

The following procedure should be used to glue the taped Fuselage parts together, using CA and accelerator.

1. Hold the parts to be joined in position.
2. Run CA into the joint.
3. Spray accelerator on the joint.

Glue short sections, 2" to 3" (51mm to 76mm) at a time, working around the masking tape. **Do not** remove the masking tape until told to do so. **Caution:** Read all warnings and cautions on the label of the accelerator you are going to use. Be sure to have adequate ventilation to avoid breathing the fumes.

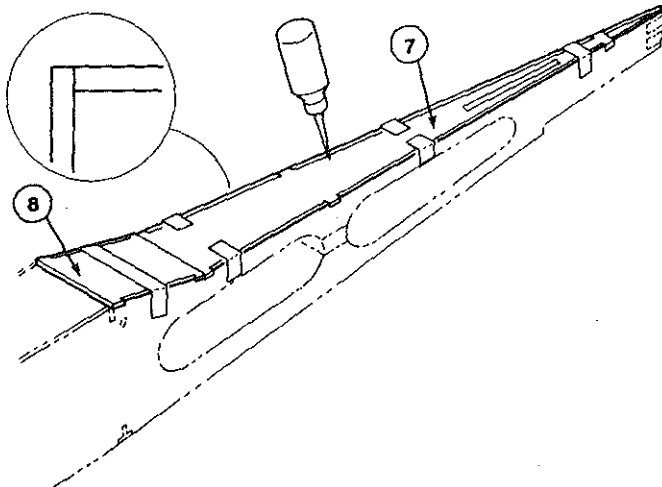

- 54. Using CA and accelerator, glue part seven (7) to both Fuselage Sides. Be sure to align the top edges of part seven (7) even with the inside edges of the Fuselage Sides, as shown. **Do not** glue the Tailpost together at this time.
- 55. Using CA and accelerator, glue part eight (8) to both Fuselage Sides. Be sure to align the top edges of part eight (8) even with the inside edges of the Fuselage Sides, as shown.

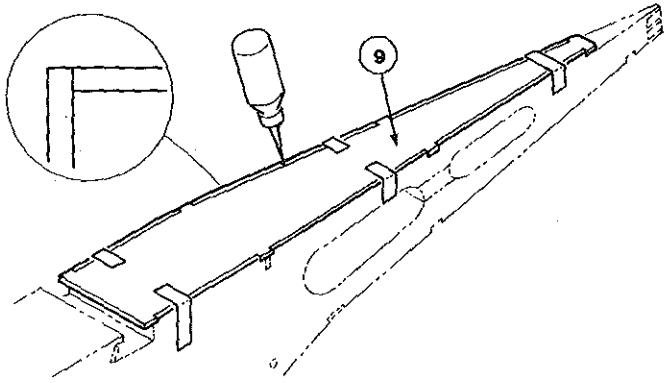

- 56. Using CA and accelerator, glue part nine (9) to both Fuselage Sides. Be sure to align the edges of part nine (9) even with the inside edges of the Fuselage Sides, as shown.

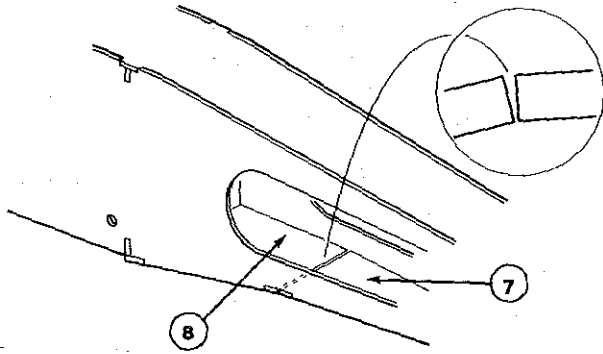

- 57. Hold the Fuselage upside down. Fill the joint between parts seven (7) and eight (8) on the inside of the Fuselage with Slow CA, as shown. Spray the joint with accelerator, filling the gap and creating a strong joint.

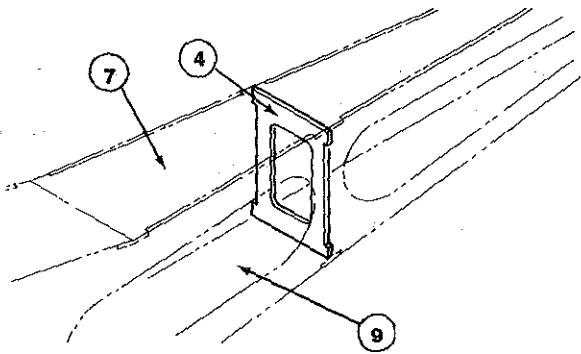

- 58. Using Slow CA and accelerator, glue part four (4) to the Fuselage Sides and to parts seven (7) and nine (9).

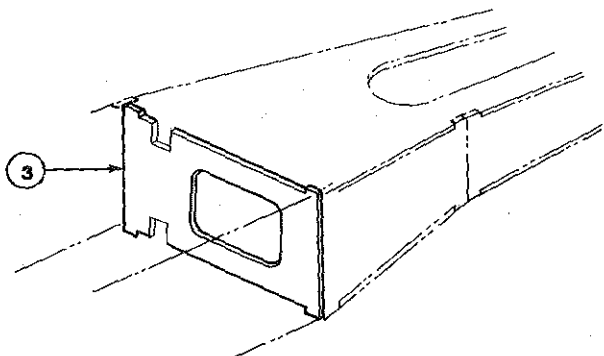

- 59. Lay the Fuselage on its side on the building board. Press down gently on the Fuselage Side over the area of part three (3). Glue part three (3) to both Fuselage Sides with CA and accelerator.

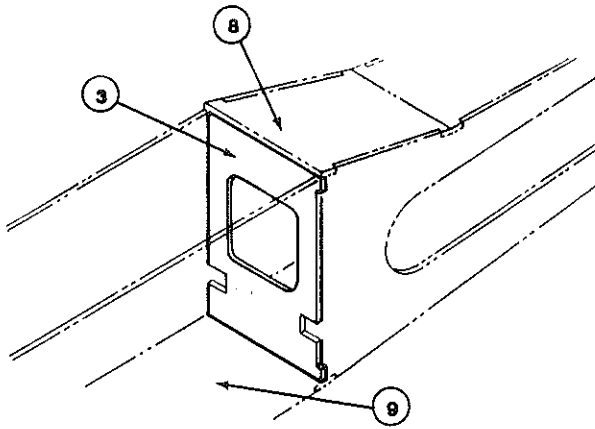

- 60. Lay the Fuselage right side up on the building board. Press down gently on top of part eight (8). Using CA and accelerator, glue parts eight (8) and nine (9) to part three (3).

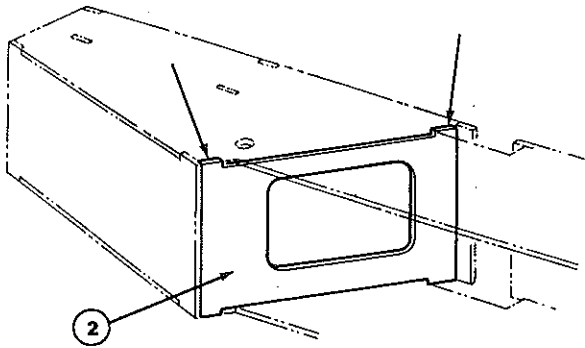

- 61. Lay the Fuselage on its side on the building board. Gently press down on the Fuselage Side, near the upper tab of part two (2), with your thumb. At the same time, push the upper tab forward with your finger. This will seat the tab in its slot in the Fuselage Side. While holding the tab in position, glue it in place with CA and accelerator.
- 62. Repeat instruction #61 to seat and glue the lower tab on part two (2).
- 63. Repeat instructions #61 and #62 to seat and glue the tabs on the opposite Fuselage Side.

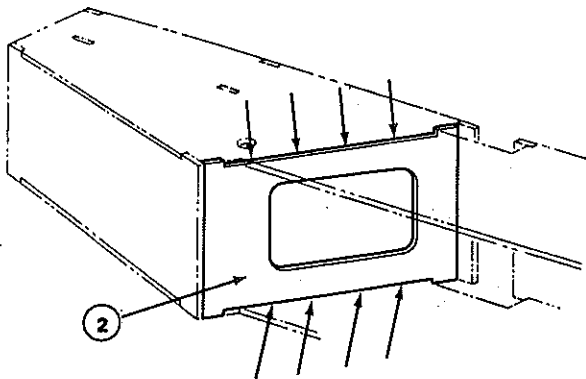

- 64. Lay the Fuselage on its side on the building board. Gently press down on the Fuselage side over part two (2). Glue only the sides of part two (2) to the Fuselage Sides with CA and accelerator.

Note: Do not glue the top or bottom of part two (2) at this time.

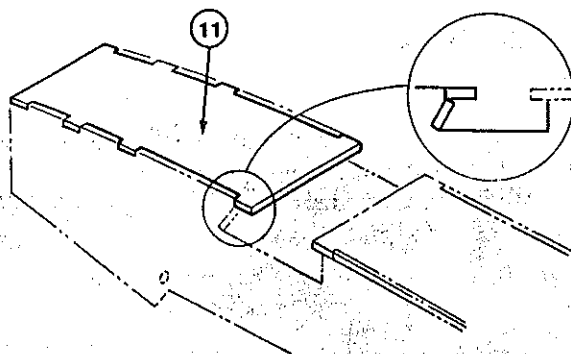

- 65. Using CA and accelerator, glue part eleven (11) to both Fuselage Sides. Be sure to align the edges of part eleven (11) with the inside edges of the Fuselage Sides, as shown.

Note: There are no slots on the Fuselage for the tabs on part eleven (11) that rest over the Gear Block Opening. These tabs can be pushed slightly into the Gear Block Opening. Be certain that these tabs are flush with the inside edges of the Fuselage Sides, as shown, before gluing them in place.

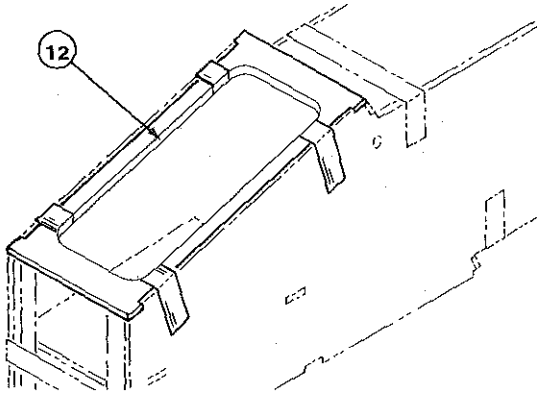

- 66. Using CA and accelerator, glue part twelve (12) to both Fuselage Sides. Be sure to align the top edges of part twelve (12) with the inside edges of the Fuselage Sides, as shown.

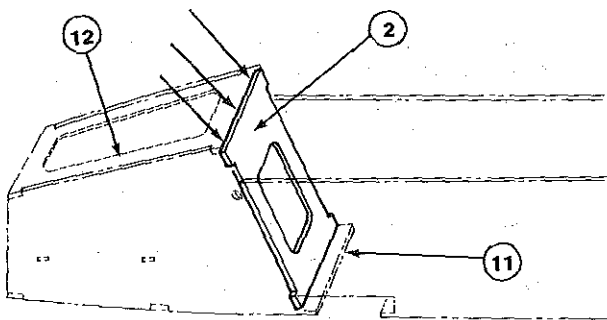

- 67. Press part twelve (12) into contact with part two (2). Glue this joint with accelerator.

Note: The joint between the bottom of part two (2) and part eleven (11) will be glued when the Landing Gear Block is installed. Do not glue it in place at this time.

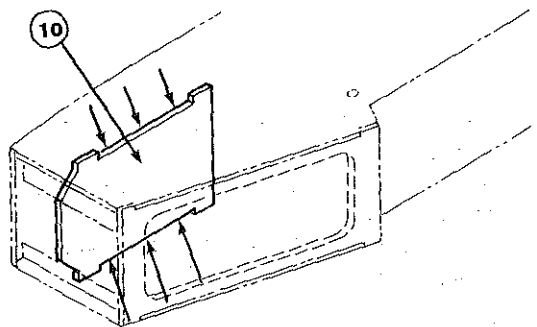

- 68. Lay the Fuselage on its side. Gently press down on the Fuselage Side in the area of part ten (10). Glue part ten (10) to both Fuselage Sides.

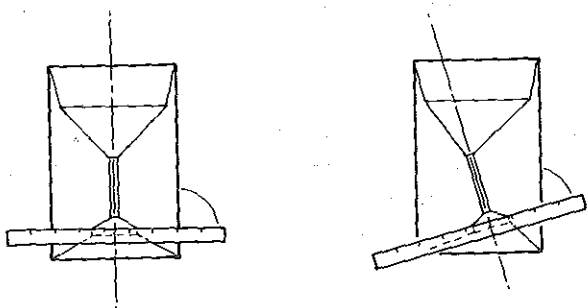

- 69. Re-check the alignment of the Tailpost with the Fuselage Sides. When it is correct, glue the Tailpost by running CA down the inside of the joint from the Stabilizer Saddle. Then, spray accelerator on the joint.

- 70. Remove all of the masking tape from the Fuselage. As you remove each piece, apply CA to that area. Check all joints for gaps and re-glue if necessary. Large gaps can be filled with Slow CA and accelerator.

Note: If CA has bonded some of the masking tape to the wood, it can be removed with a sanding block.

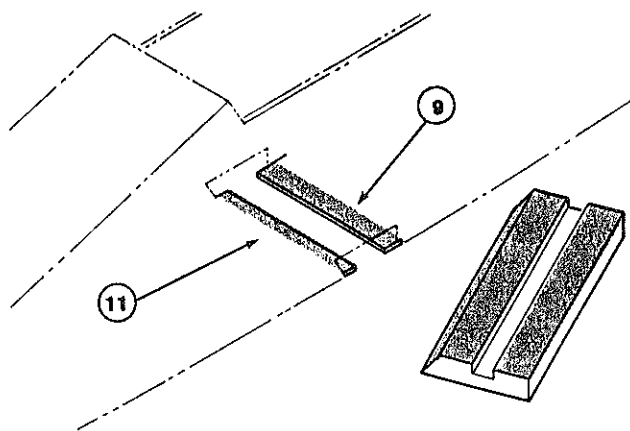

- 71. Spray accelerator on the bottom of the maple Landing Gear Block and on the inside of parts nine (9) and eleven (11) where they overhang the Gear Block Opening.

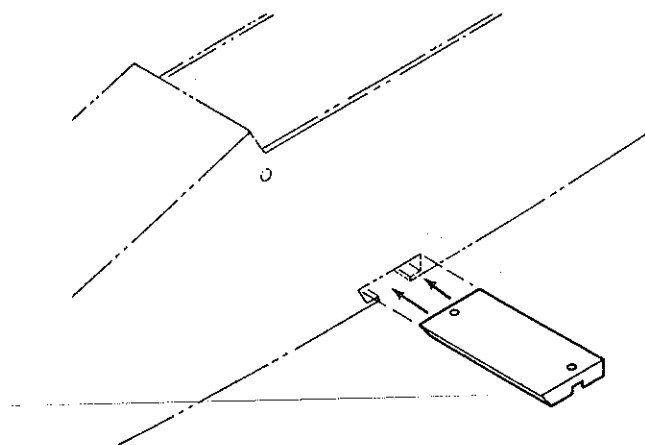

- 72. Test fit the Landing Gear Block in the Landing Gear Opening, as shown. It should fit snugly in the Gear Block Opening and against parts nine (9) and eleven (11).
- 73. Following the directions on the bottles, mix about 1/2 ounce of slow drying epoxy. Using a narrow strip of scrap wood, spread the epoxy in the joint between the bottom of part two (2) and part eleven (11) that overhangs the Gear Block Opening.

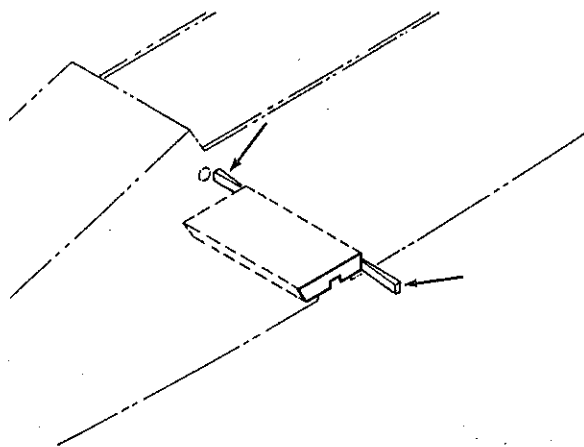

- 74. Slide the Landing Gear Block into position in the Gear Block Opening. Push forward on the Gear Block. If it moves forward, cut wedges from scrap wood and push them between the Landing Gear Block and the Fuselage Sides, as shown. The Landing Gear Block should butt against part two (2)

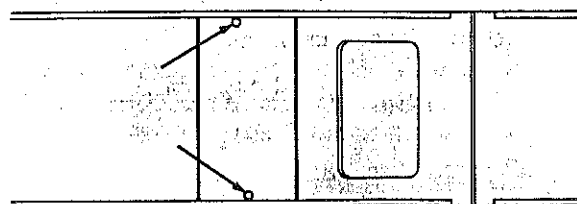

- 75. Align the Landing Gear Block so that the edges of the two holes in the block are even with the inside edges of the Fuselage Sides.

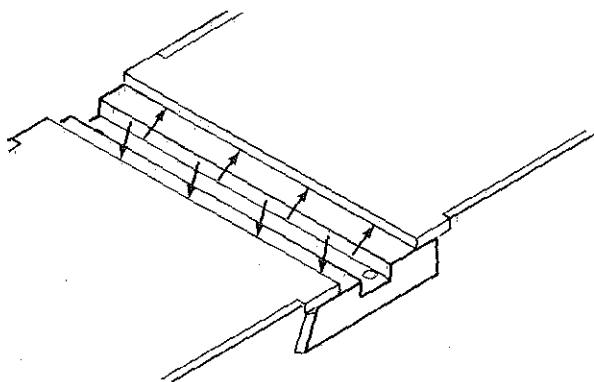

- 76. Lay the Fuselage upside down on the building board. Press parts nine (9) and eleven (11) into contact with the Landing Gear Block and apply CA to the joints. Then, apply CA to the joints between the Landing Gear Block, the Fuselage Sides, and part two (2), on the inside of the Fuselage.

Note: If you used the wedges in instruction #74, remove them after completing instruction #76.

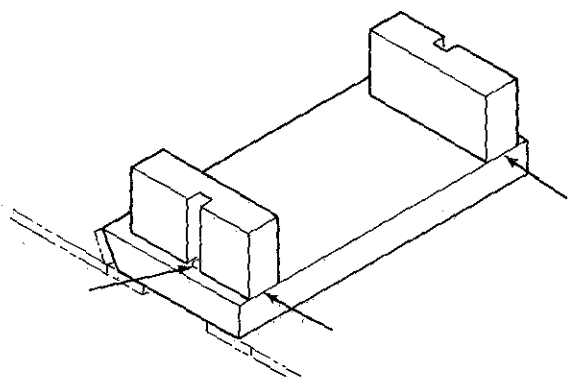

- 77. Fit the two maple Torque Blocks against the Landing Gear Block and the Fuselage Sides. The slots in the Torque Blocks should be aligned over the holes in the Landing Gear Block and their back edges should be almost even with the back edge of the Landing Gear Block. If one or the other doesn't fit in this manner, turn it over and reposition it.
- 78. Apply Slow CA to the slotted side and bottom of one Torque Block. Align its slot over the hole in the Landing Gear Block and press it into contact with the Landing Gear Block and the Fuselage Side. Hold it in position until the Slow CA cures (about 15 seconds).
- 79. Repeat instruction #78 to install the opposite Torque Block.

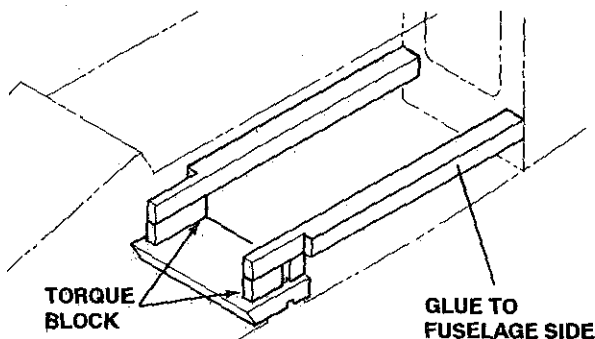

- 80. Apply Slow CA to the top of one Torque Block and the notched side of one 3/8" x 3/8" x 9-9/16" (9.5mm x 9.5mm x 243mm) basswood Servo Rail. Press the servo rail against the top of the Torque Block and into the notch in part three (3). Align the notch in the Servo Rail with the Fuselage Doubler so that the servo rail sets flat against the Fuselage Side.
- 81. Repeat instruction #80 to install the opposite Servo Rail.

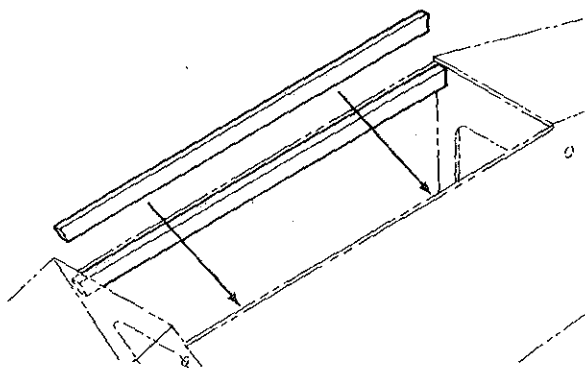

- 82. Fit the pre-cut 1/2" x 1/2" x 12-25/32" (12.7mm x 12.7mm x 325mm) Wing Saddle Doublers flush with the inside edges of the Fuselage, as shown. The Wing Saddle Doublers should also contact parts two (2) and three (3) when in position. If they are too long, trim the rear edge of the Wing Saddle Doubler to obtain the correct fit.
- 83. Apply Slow CA to one Wing Saddle Doubler and press it into position.
- 84. Repeat instruction #83 to install the opposite Wing Saddle Doubler.

Firewall

The Aero-Star's Firewall is pre-drilled to accept the hardware supplied in the kit. If you must use different hardware, you may have to drill new mounting holes. Any unused holes can be filled with scrap balsa and sealed with CA.

Note: If you intend using a four-cycle engine on your Aero-Star, a Dave Brown 60FS motor mount will fit the pre-drilled holes.

You will need the parts illustrated below to complete this sub-assembly.

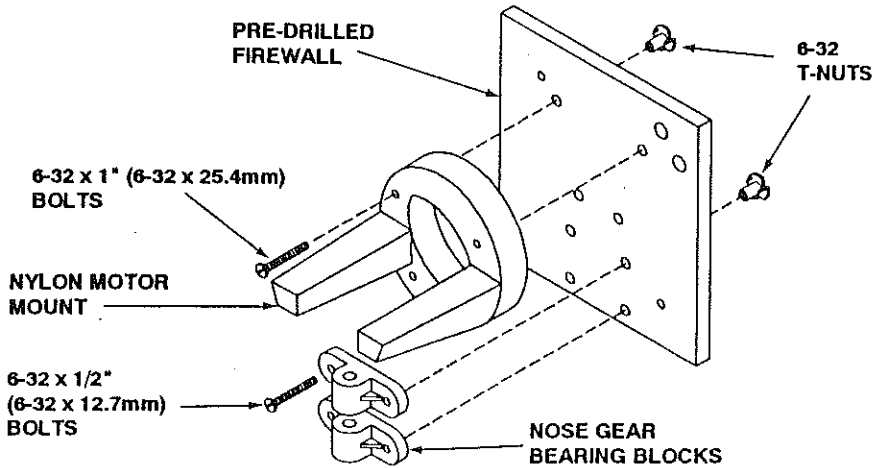

The Firewall is packed in Bag Number Three (#3). The remaining parts are packed in the Fuselage Hardware Bag.

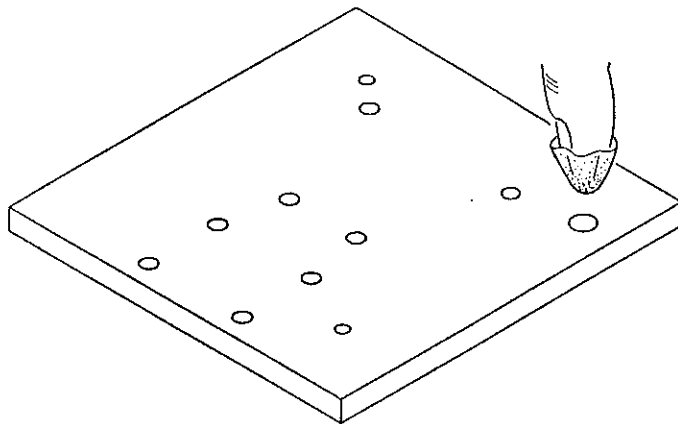

- 85. Lay the Firewall on the building board. Then, lay a small piece (about 1" (25.4mm) square) of #220 grit sandpaper over one of the 1/4" (6.4mm) holes. Press the sandpaper into the hole with the end of your finger and rotate it back and forth several times. This will remove the sharp edges from the hole. Repeat this procedure for the other 1/4" (6.4mm) hole and the opposite ends of these holes on the other side of the Firewall.

Note: Later, the Fuel Lines will be passed through these holes. This will be much easier to do if the sharp edges have been removed.

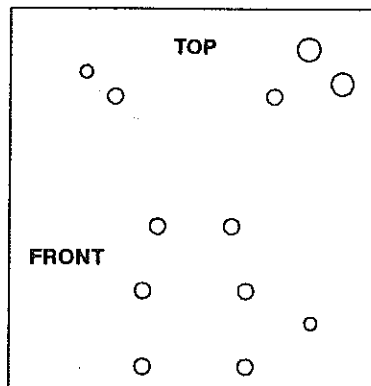

- 86. Lay the Firewall on the building board so that the holes appear as shown in the illustration at the left. Mark this side front with a pencil and write the word **top** where shown on the illustration.

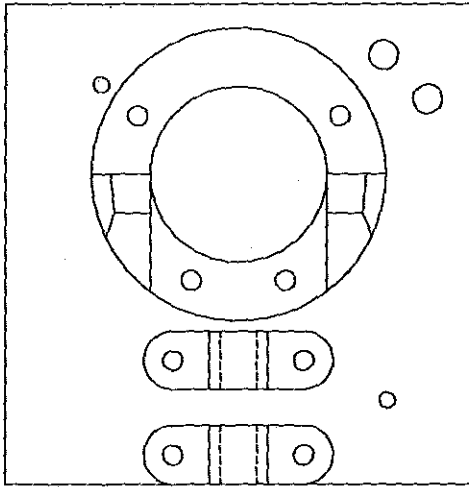

- 87. Position the Motor Mount and Nose Gear Bearing Blocks on the front side of the Firewall, as shown.

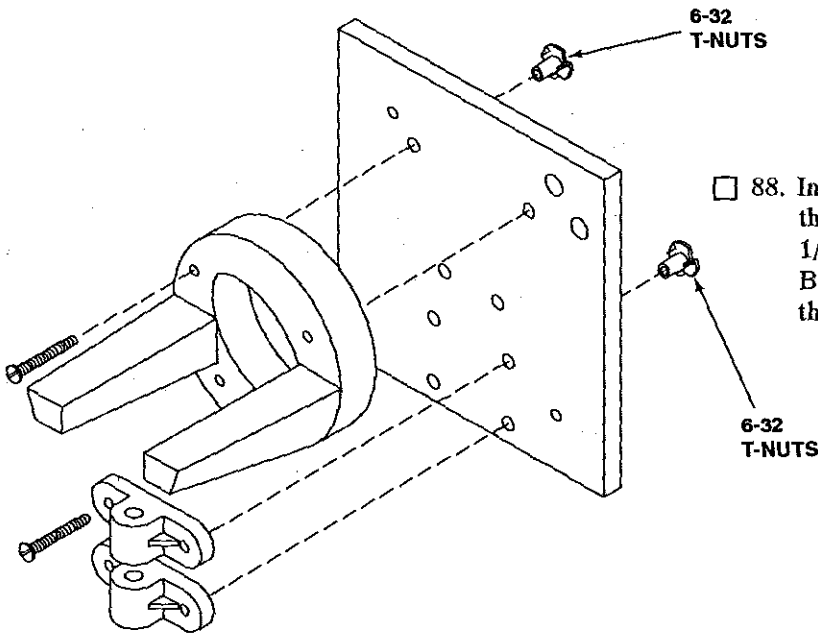

- 88. Insert the four 6-32 x 1" (6-32 x 25.4mm) bolts through the Motor Mount and Firewall. Insert the four 6-32 x 1/2" (6-32 x 12.7mm) bolts through the Nose Gear Bearing Blocks and the Firewall. Screw the t-nuts onto the bolts so that the prongs face the Firewall, as shown.

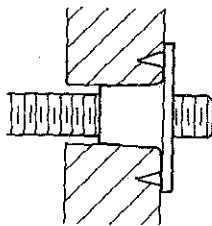

- 89. Using a screwdriver to turn the bolts, draw the t-nuts into the Firewall, as shown.
- 90. Remove all of the bolts, the Motor Mount and Nose Gear Bearing Blocks from the Firewall. Put the bolts back in the Fuselage hardware bag and place the Motor Mount and Nose Gear Bearing Blocks aside. These parts will be needed later.

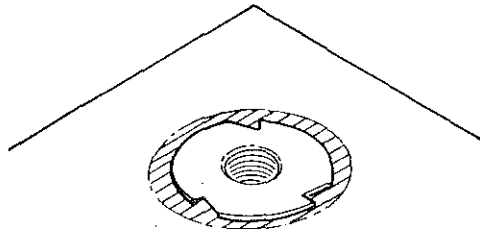

- 91. Place a small amount of oil in the threaded holes of each t-nut. Then, apply CA around the edge of each t-nut.

Note: The oil will prevent adhesives from fouling the threaded holes.

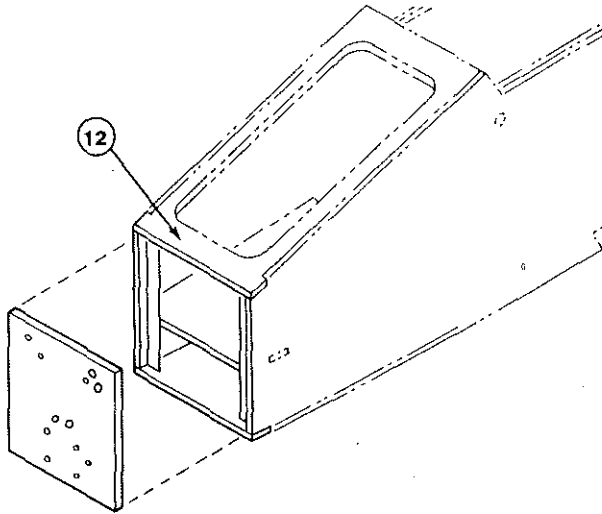

- 92. Test fit the Firewall in the front of the Fuselage with the front side facing out and the top edge against part twelve (12), as shown. It should rest solidly on the triangle stock. If the Firewall rocks while in position, shave the front edge of part ten (10) with an X-Acto[®] knife until it is flush with the front sides of the triangle stock.

Note: At this point, it is possible that the opening for the Firewall is not square. If this is the case with your model, insert one side of the Firewall into the opening and wiggle it into position. When the Firewall is glued in place, it will square-up the front of the Fuselage.

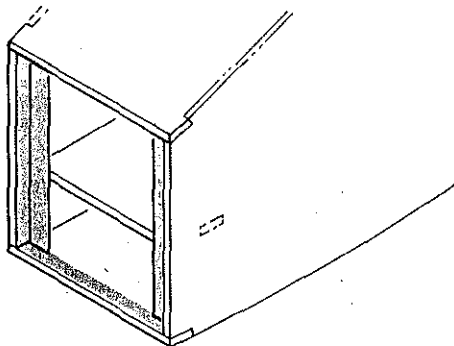

- 93. Following the directions on the bottles, mix about one (1) ounce of epoxy. Spread a layer of epoxy about 1/16" (1.5mm) thick and about 1/4" (6.4mm) wide around the inside of the opening in the front of the Fuselage, as shown. Also, spread a thin layer of epoxy on the front of the triangle stock.

Note: Use only the amount of epoxy called for in this instruction, otherwise, the excess may clog the t-nuts.

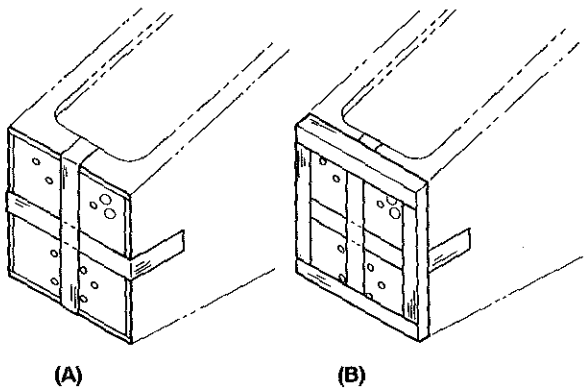

- 94. Press the Firewall into the opening in the front of the Fuselage with the front side facing out and the top side against part twelve (12). Stretch two pieces of masking tape across the Firewall, as shown in (A). Then, tape all four sides, as shown in (B).
- 95. Stand the Fuselage upright on the Firewall. Leave it in this position until the epoxy has cured (about 2 hours, or as per the directions for the epoxy). Then, remove the masking tape.

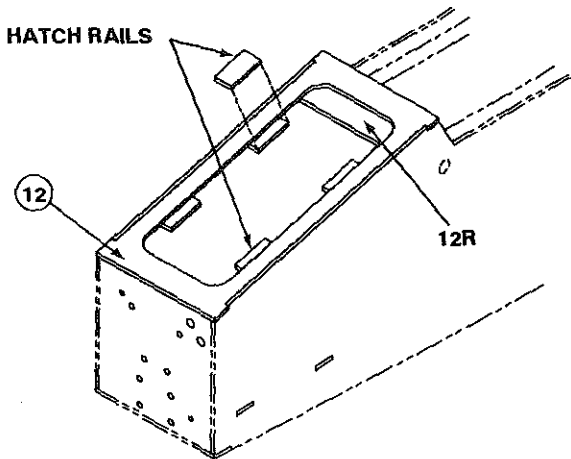

- 96. Using Slow CA, glue the Hatch Rails on the underside of part twelve (12), as shown on the Fuselage plan. Leave at least 1/8" (3.2mm) of overhang for the hatch to set on.
- 97. Position part 12R on the underside of part twelve (12), as shown. Leave at least 1/2" (12.7mm) of overhang to allow for the Hatch Screw. Glue part 12R to part twelve (12) with Slow CA.

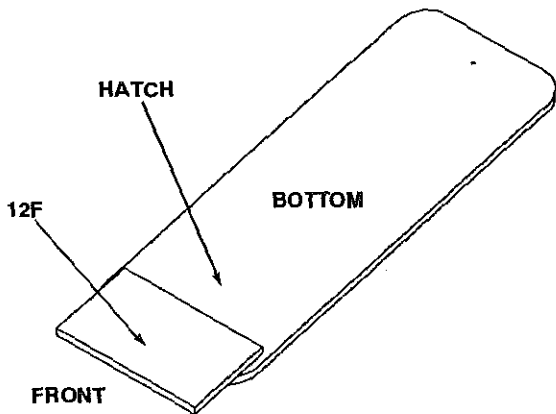

- 98. Glue part 12F to the front of the Hatch, on the bottom, as shown.

Note: The rear end of the Hatch has the indentation for the Hatch screw.

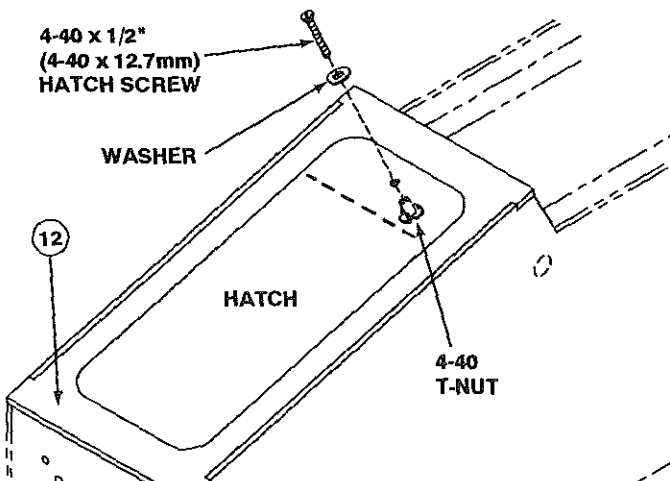

- 99. Set the Hatch on the Fuselage, as shown, and drill through the Hatch and part 12R with a 5/32" (4mm) drill bit. Using a pair of pliers, set the 4-40 t-nut into the bottom of part 12R. Secure the Hatch to the Fuselage with the 4-40 x 1/2" (4-40 x 12.7mm) Hatch Screw and #4 Flat Washer, as shown.
- 100. Using a sanding block, sand all of the joints on the Fuselage smooth.

About The Wings

Note: Before going further, it may be helpful to read "The Controls" under the section titled "Flying", pages #92 - #95.

The Aero-Star's wings are built directly on the plan, using a pattern to position the parts. Shortly after construction is started, the drawing of the Wing Panel you are building will be covered by the parts that make up the underside of that panel. For this reason, we suggest that you build the left Wing Panel first, using the drawing of the opposite Wing Panel as a reference for part locations. There are two sets of check-off boxes for this section. Use one set of the boxes while building one panel and the other set while building the opposite panel.

Note: All of the parts for the Wings are pre-cut to size. Do not cut any parts unless told to do so.

The Wing Ribs are in Bag Number Five (5). The Dihedral Gauge is in Bag Number Three (3). All other parts are in Bag Number Four (4). All of the parts for both Wing Panels are in these bags.

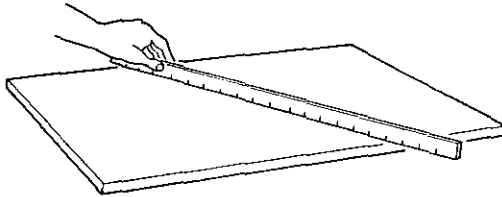

101. Stand a 48" (1219mm) straight edge, against your building board. Move it around the board and note any high or low spots. Use thin shims, made from scrap wood and placed under the board, to correct any irregularities. Also, sight across the board at eye level. Look for any twists or bowing in the board. When you are finished, your building board should be flat.

Note: Both Wing Panels will be built on this board. If the board is twisted, or bowed, the Wings will assume this shape. No amount of work later on will correct this, and the model may not fly properly.

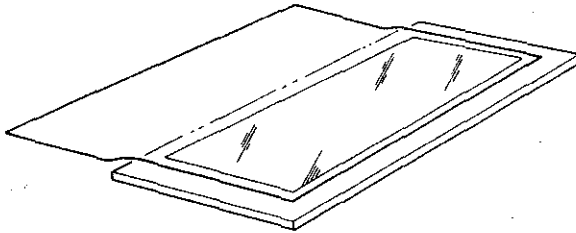

102. Lay the left wing plan on the building board. (The right Wing Plan if you are repeating these instructions.) Be certain that the drawing for the panel you are building is completely on the board. Then, cover the drawing for that panel with plastic wrap.

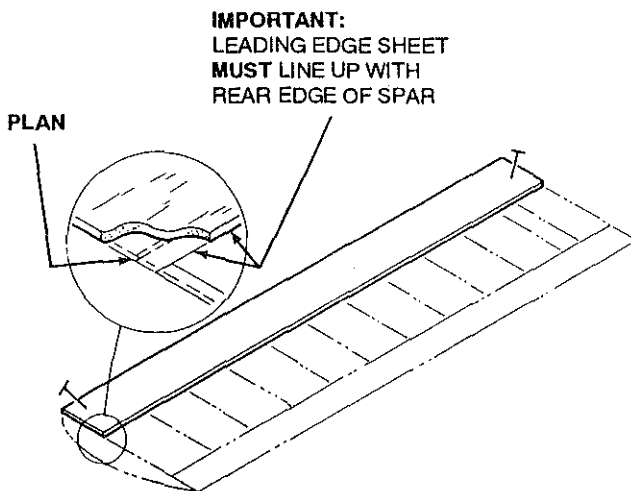

103. Position one $\frac{3}{32}$ " x $3\text{-}\frac{9}{32}$ " x $35\text{-}\frac{7}{8}$ " (2.3mm x 83.3mm x 911mm) balsa leading edge sheet over the drawing of the leading edge sheet on the plan, as shown. Align the ends even with the ends on the drawing. Align the rear edge so it is even with the rear edge of the drawing of the spar, as shown. Pin the ends of the sheet to the building board, using one t-pin at each end.

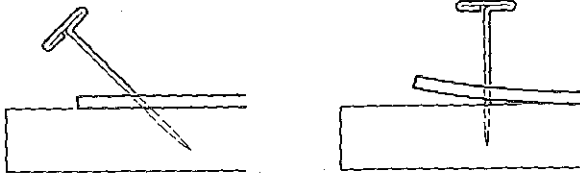

Note: The t-pins are used to hold parts in contact with the building board. To do this, they must be pushed through the part and into the board at an angle, as shown. Pushing them straight through a part will allow it to pop up.

When removing a t-pin from a part, you may find that the CA has bonded it to the part. If this happens, twist the t-pin to break it free before pulling it out.

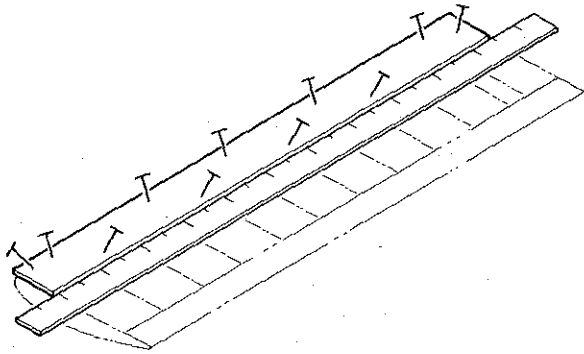

- 104. Lay a 48" (1219mm) straight edge against the rear edge of the leading edge sheet, as shown. Pull the center of the sheet into contact with the straight edge. When the entire edge is in contact with the straight edge, pin the center portion of the leading edge to the building board. Then, add as many t-pins as necessary to pin the leading edge sheet flat on the board.

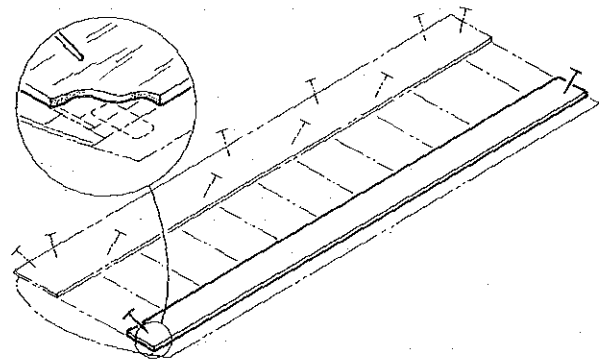

- 105. Position one $\frac{3}{32}$ " x $1\text{-}\frac{7}{8}$ " x $35\text{-}\frac{7}{8}$ " (2.3mm x 47.6mm x 911mm) trailing edge sheet over the drawing of the trailing edge sheet on the plan. Align the ends of the sheet even with the ends of the drawing. Align the rear edge of the trailing edge sheet with the rear edge on the drawing and pin the ends to the building board.

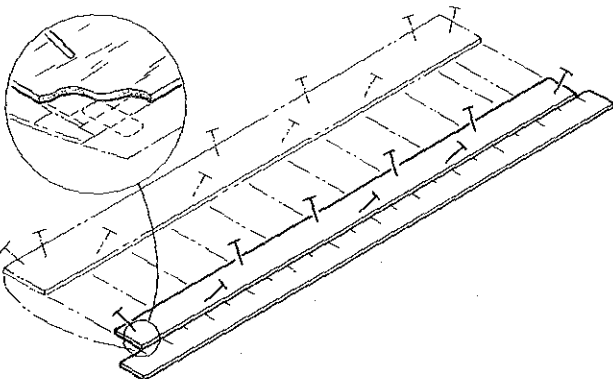

- 106. Lay a straight edge against the rear edge of the trailing edge sheet. When the entire rear edge is in contact with the straight edge, pin the center of the trailing edge sheet to the building board. Then, add as many t-pins as necessary to pin the trailing edge sheet flat on the board.

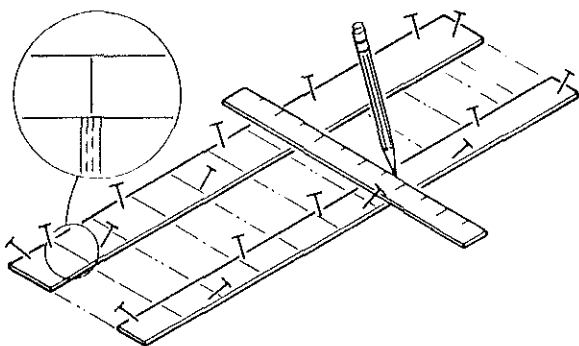

- 107. Using a pencil and a straight edge, lightly mark the rib locations across the leading and trailing edge sheets, as shown.

Note: Once the cap strips are glued into position, in the following instructions, the rib locations will be hidden. Be sure your pencil marks are visible and drawn all the way across both the leading and trailing edge sheets. Be careful not to crush, or tear, the wood while drawing these lines as that will weaken these parts.

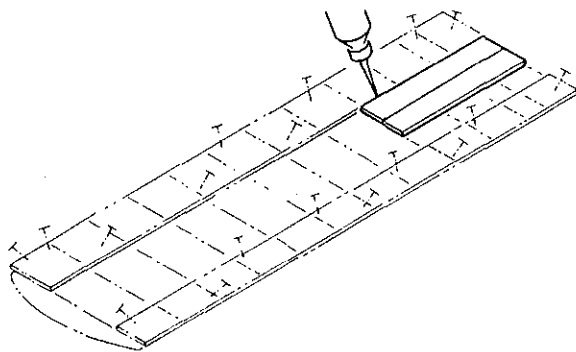

- 108. Position one $\frac{3}{32}$ " x $2\text{-}\frac{7}{8}$ " x $9\text{-}\frac{7}{8}$ " (2.3mm x 73mm x 251mm) center section sheet over the drawing of the forward center section sheet on the plan. Butt it against the leading edge sheet so that the ends of these parts are even, as shown on the plan. Lightly press the center section sheet flush against the leading edge sheet and run CA into the joint, as shown. Position another center section sheet behind the first and glue them together using the same method.

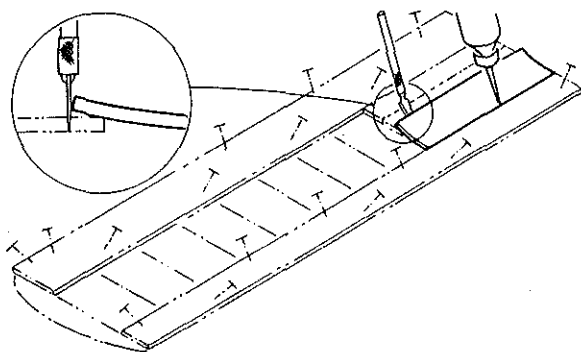

- 109. Position one $\frac{3}{32}$ " x $2\text{-}\frac{7}{8}$ " x $9\text{-}\frac{7}{8}$ " (2.3mm x 73mm x 251mm) center section sheet between the forward center section sheets and the trailing edge sheet. Butt this sheet against the trailing edge. Lay the front edge on top of the forward center section sheet, aligning the ends with the forward sheets, as shown. Run CA into the joint between the trailing edge sheet and this part.

- 110. Hold your X-Acto[®] knife so the blade is against the overlap in the center section sheets, as shown. Using the overlapped rear sheet as a guide, carefully cut through the forward center section sheet and remove the cut off portion. Then, press the rear sheet down so that the joint between these parts becomes flush. Apply CA to this joint.

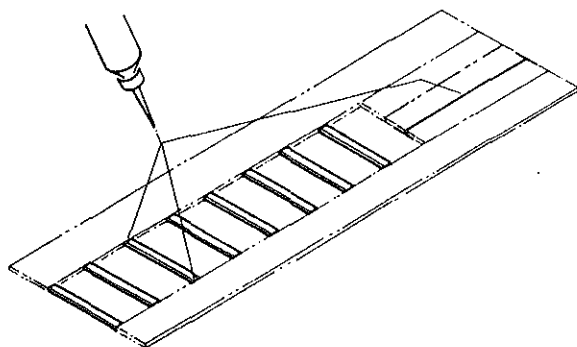

- 111. Using the $\frac{3}{32}$ " x $\frac{1}{4}$ " x $6\text{-}\frac{7}{8}$ " (2.3mm x 6.4mm x 175mm) balsa strips, cut the cap strips to fit snugly between the leading and trailing edge sheets at the locations shown on the plan. Glue each strip to the leading and trailing edge sheeting with CA.

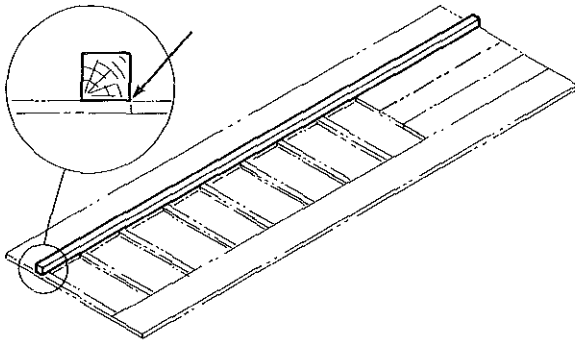

- 112. Apply Slow CA to one side of the 3/8" x 3/8" x 35-7/8" (9.5mm x 9.5mm x 911mm) spruce spars. Position the ends of the spar even with the ends of the leading edge sheet. Carefully, lay the spar flush on the rear edge of the leading edge sheet, as shown. When the spar is in position, press it into contact with the leading edge sheet along its full length.

Note: Dihedral refers to an angle formed by the two Wing Panels that gives the model stability.

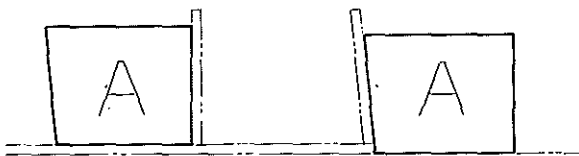

ALL OTHER RIBS

ROOT RIB

The dihedral gauge is the Shear Web marked "A". It will be used to help position the ribs. It is to be held against each rib, as shown. The root rib must be installed at an angle to allow for the Wing's dihedral. The dihedral gauge will be used to establish this angle, as shown. The dihedral gauge will also be used later as a shear web.

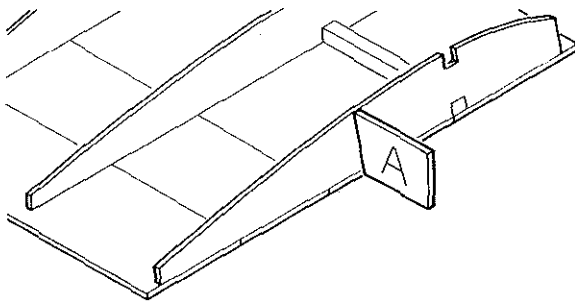

- 113. Position the root rib flush on the edge of the balsa sheeting. Using the dihedral gauge/shear web "A", glue the root rib to the sheeting in short sections, moving the dihedral gauge along as you apply the CA.

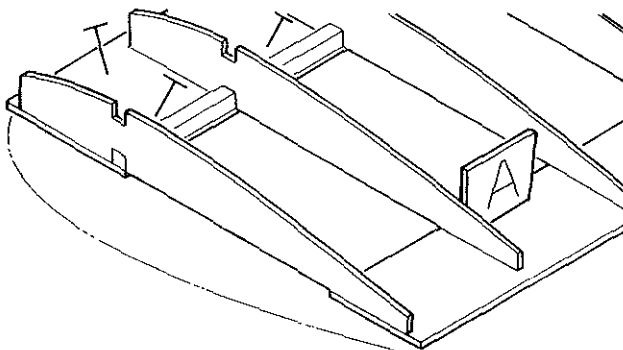

- 114. Using the dihedral gauge/shear web "A", stand the ribs in position on the leading and trailing edge sheets. Align each rib on the pencil lines and glue them to the sheeting and cap strips with CA. Be sure that the tip rib is even with the ends of the sheeting, as shown.

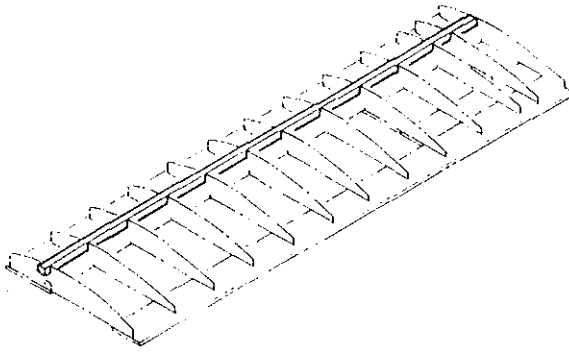

- 115. Insert one $3/8" \times 3/8" \times 35-7/8"$ (9.5mm x 9.5mm x 911mm) spruce spar into the notches in the tops of the ribs. Align it so that one end is even with the outside edge of the root rib. The other end will stick out slightly beyond the end of the tip rib. Adjust the spar so that it is flush with the tops of all of the ribs. Then, apply CA to the joints.

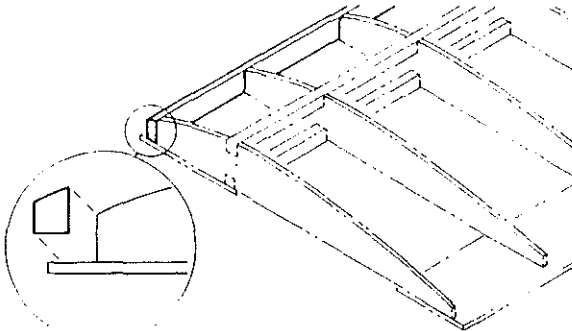

- 116. Apply a bead of Slow CA to the leading edge sheet, just ahead of the ribs. Position a pre-shaped $3/8" \times 3/4" \times 35-7/8"$ (9.5mm x 19mm x 911mm) balsa leading edge against the ribs, even with the ends of the leading edge sheet. Press it into contact with the leading edge sheet, as shown. Then, apply CA to the joints between the ribs and the leading edge.

Note: The leading edge sheet will stick out beyond the front of the pre-shaped leading edge. It will be trimmed later in construction.

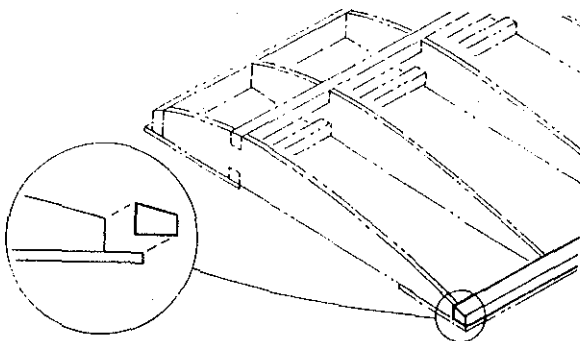

- 117. Apply a bead of Slow CA to the trailing edge sheet, just behind the ribs. Position a pre-shaped $3/8" \times 3/8" \times 35-7/8"$ (9.5mm x 9.5mm x 911mm) balsa trailing edge against the ribs, even with the ends of the trailing edge sheet. Press it into contact with the trailing edge sheet. Then, apply CA to the joints between the ribs and the trailing edge.

Note: If any of the top edges of the ribs stick up above the tops of the leading or trailing edges at the joints, use a sanding block to sand these joints flush.

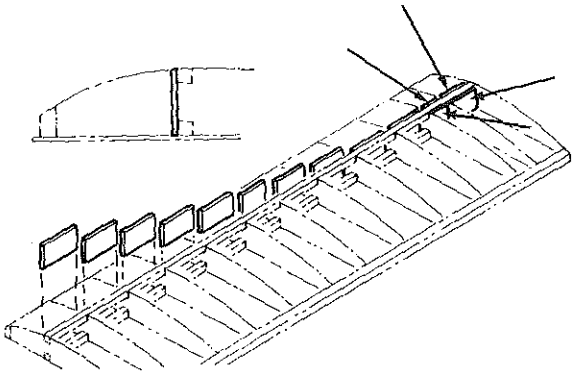

- 118. Glue the pre-cut balsa shear webs to the front side of the spars as shown, using Slow CA. Also, install the shear webs "B" and the dihedral gauge/shear webs "A" between the first two ribs, on both sides of the spars, as shown on the wing plan. Note that the wood grain of the shear webs runs vertically. Study the drawing of the opposite Wings Panel to help you locate the correct locations for the webs.

Note: Due to slight differences in construction techniques, it may be necessary to trim the shear webs to fit between the ribs. If a small gap results between the ribs and shear webs, it's ok. The important thing is to be sure that each shear web is bonded securely to both spars. These webs add a great deal of bending strength to the Wing.

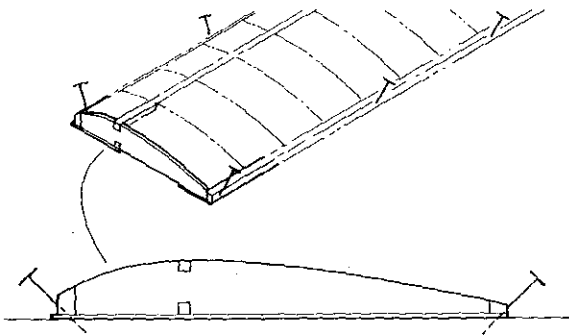

- 119. Pin the leading and trailing edges to the building board, as shown. Then remove all of the other t-pins that are between the ribs.

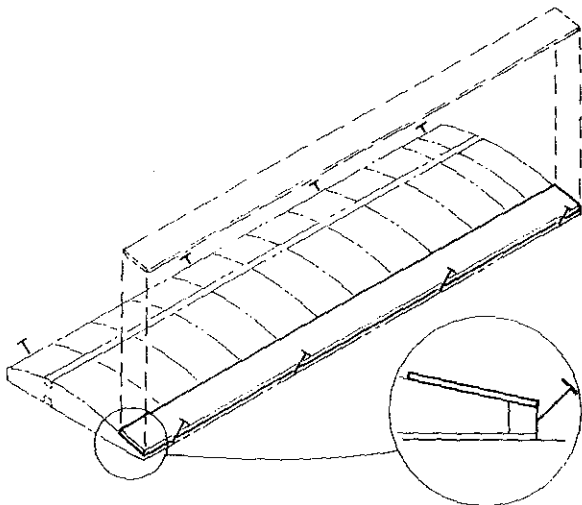

- 120. Apply a bead of Slow CA to the top of the trailing edge and the ribs, where the trailing edge sheet will contact these parts. Then, position a $\frac{3}{32}$ " x $1\frac{7}{8}$ " x $35\frac{7}{8}$ " (2.3mm x 47.6mm x 911mm) trailing edge sheet even with the ends and back edge of the trailing edge. Press it into contact with the trailing edge and the ribs.

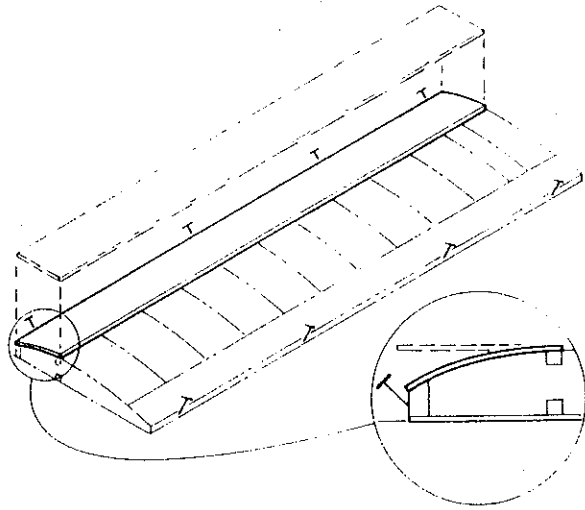

- 121. Apply a bead of Slow CA to the leading edge, the top of the spar, and the tops of the ribs between the leading edge and spar. Position a $3/32" \times 3-9/32" \times 35-7/8"$ ($2.3\text{mm} \times 83.3\text{mm} \times 911\text{mm}$) balsa leading edge sheet so that it is flush with the rear edge and even with the ends of the spar only. Press it into contact with the spar only. When the Slow CA has "grabbed", lay your hands flat on the center portion of the sheet. Roll it over the ribs and into contact with the leading edge. When the CA has grabbed on the leading edge, roll the ends of the sheet into contact with the leading edge.

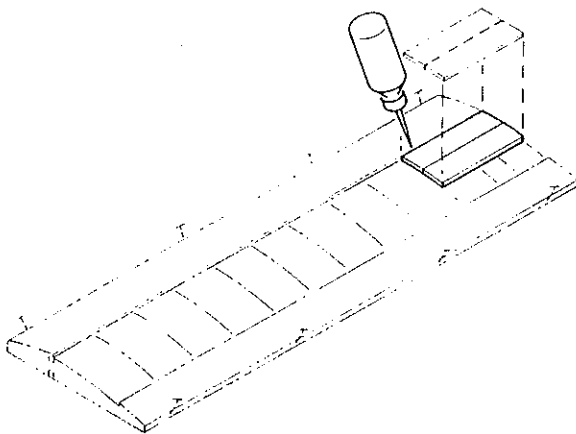

- 122. Using Slow CA, glue one $3/32" \times 2-7/8" \times 9-7/8"$ ($2.3\text{mm} \times 73\text{mm} \times 251\text{mm}$) center section sheet to the leading edge sheet and the ribs, as shown. Position it so that the edge is even with, and over, the root rib. Position a second center section sheet behind the first and glue in place.

Note: When gluing these upper center section sheets, press the sheets against each other. Do not press down on them at the JOINTS between the sheets. Pressing down will cause the edges to slip out of alignment.

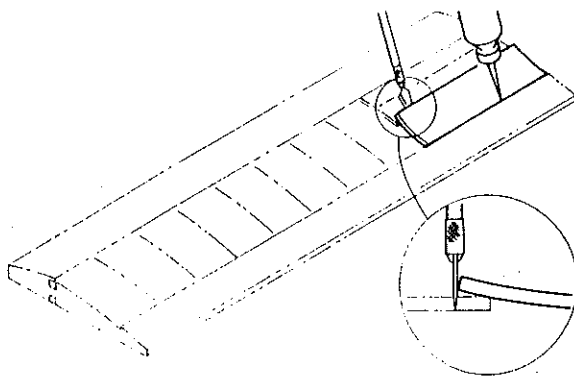

- 123. Lay one $3/32" \times 2-7/8" \times 9-7/8"$ ($2.3\text{mm} \times 73\text{mm} \times 251\text{mm}$) center section sheet between the forward center section sheets and the trailing edge sheet, butting it against the trailing edge sheet. Using the portion of this sheet that overlaps the forward center section sheet as a cutting guide, cut through the forward center section sheet with an X-Acto[®] knife, as shown. Remove the cut off portion of the forward sheet.

- 124. Apply Slow CA to the ribs and to the edges of the trailing edge sheets and the forward center section sheet. Align the edges of this rear sheet with the edges of the forward center section sheet and press it into contact with the ribs.

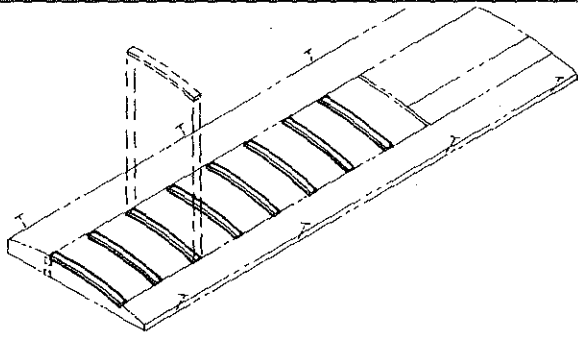

- 125. From the 3/32" x 1/4" x 6-7/8" (2.3mm x 6.4mm x 175mm) balsa strips, cut the cap strips to fit over the ribs and snugly between the leading and trailing edge sheets. Glue them to the ribs with Slow CA.

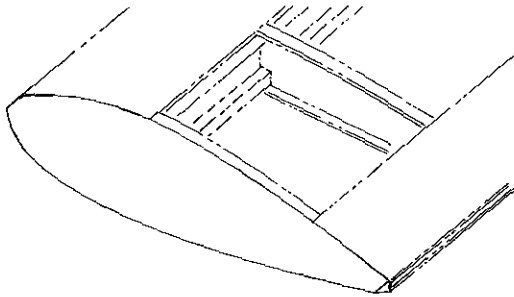

- 126. Apply Slow CA to the tip rib and position the left Wing Tip Block on the tip rib with the top edge even with the wing sheeting and cap strips. You will also want to center the front and rear ends of the wing tip block between the leading and trailing edges.

Note: The Wing Tip Block will have a small amount overhang on the bottom. This is ok, it will be sanded off later.

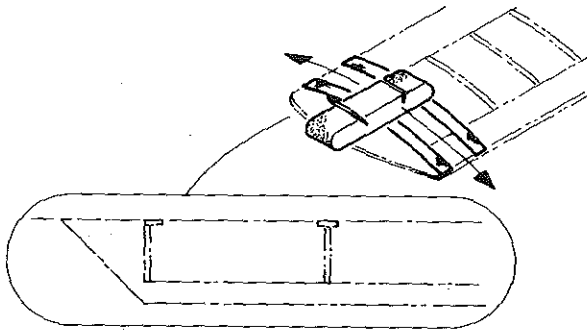

- 127. Apply masking tape around the Wing, at the tip and next rib locations, as shown. Using a sanding block, sand the Wing Tip Block to make the bottom flush with the wing and match the contour of the wing all around.

Note: The masking tape will prevent you from sanding through the Wing sheeting. If the Wing Tip is not contoured before the tape is worn through, replace the tape.

- 128. Remove the Wing from the building board. Trim the bottom leading edge sheet flush with the leading edge. Then, using a sanding block, sand all of the joints on the wing flush.

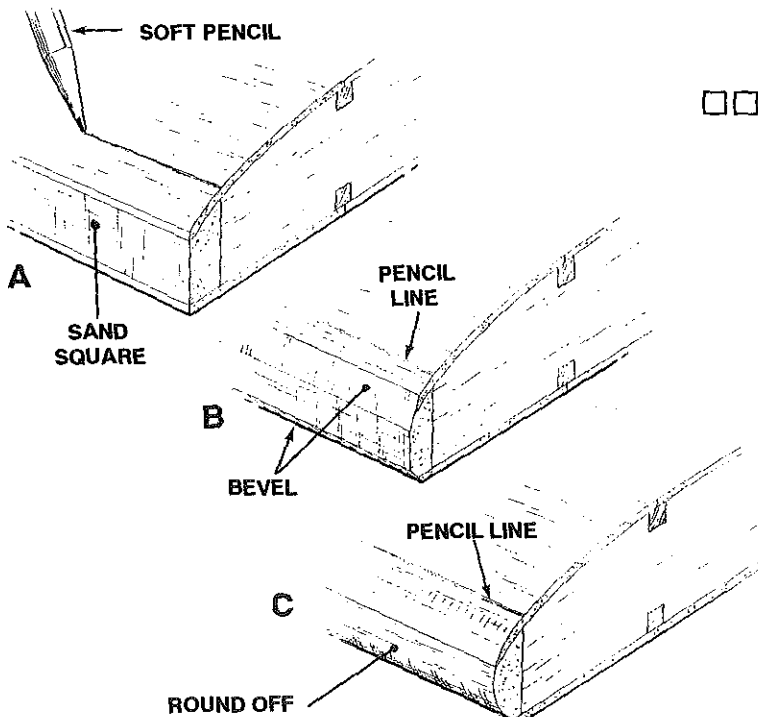

- 129. (A) Glue a piece of #220 grit sandpaper to a block 8" to 10" (203mm to 254mm) long, and wide as can be comfortably held in the hand. Trim and square up the leading edge. Use a soft pencil to lightly mark a line immediately above the rear edge of the leading edge. This line should run from the wing center out to the tip, and should be repeated on the underside of the leading edge.

(B) Use the sanding block to sand a bevel above and below the leading edge. **Do not** bevel back to the pencil line. These bevels run from the wing center out to the tip.

(C) Now, use the sanding block to sand off the corners of the bevels, gradually turning the bevels into a rounded leading edge, sanding back to but **not behind** the pencil line. (This is to guard against sanding through the leading edge sheeting.)

Torque Rods

Note: Instructions #130 through #139 explain how to fit the torque rod box and ailerons to the Wing Panel.

The torque rods transfer the servo's motion to the ailerons.

You will need the parts illustrated below for this sub assembly. The torque rod box is in Bag Number Four (4).

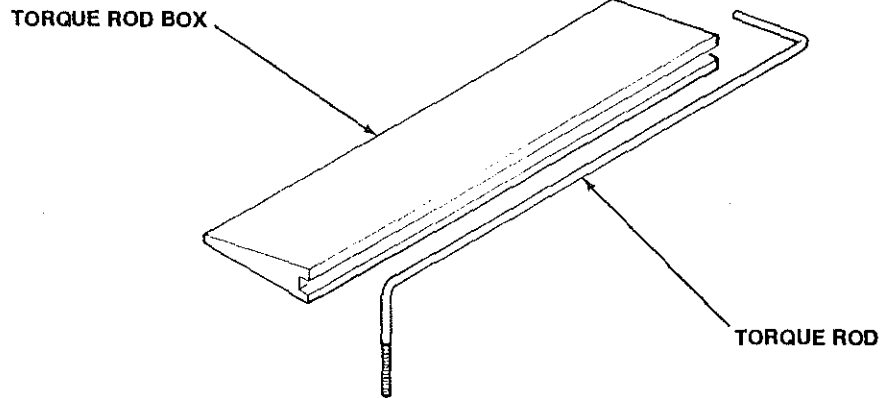

You will also need three hinges, not supplied with the kit, to complete this sub-assembly.

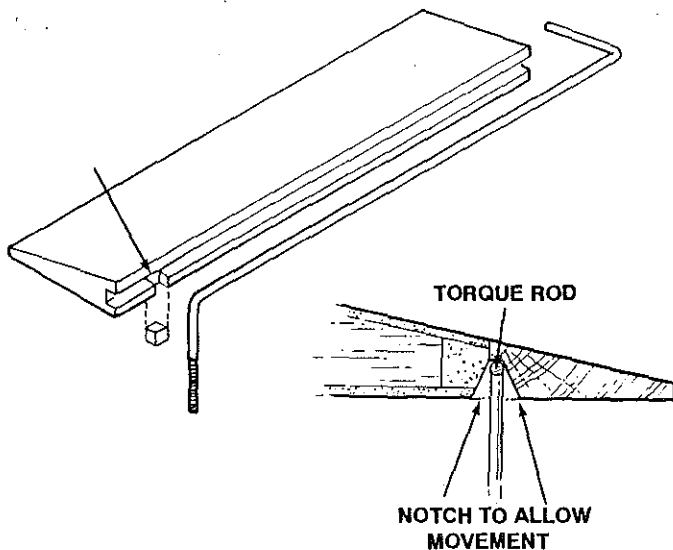

130. Position one of the torque rods, with the threaded end pointed down, on top of the left wing plan and make a 90° bend at the position shown on the plan. Trim off the excess material at the unthreaded end. This is the left torque rod. Bend the second torque rod, making sure that you use the right wing plan to make a right torque rod.

131. Apply light oil to the aileron torque rod. Insert the torque rod into the slot in the basswood torque rod box. It will be necessary to cut a groove into the bottom of the torque rod box, at the location shown on the plan. This slot will allow the threaded end of the torque rod to seat into the slot.

Note: When the torque rod box is in position on the wing, the threaded end of the torque rod should come out of the bottom (flat side) of the wing and the unthreaded end should face back!

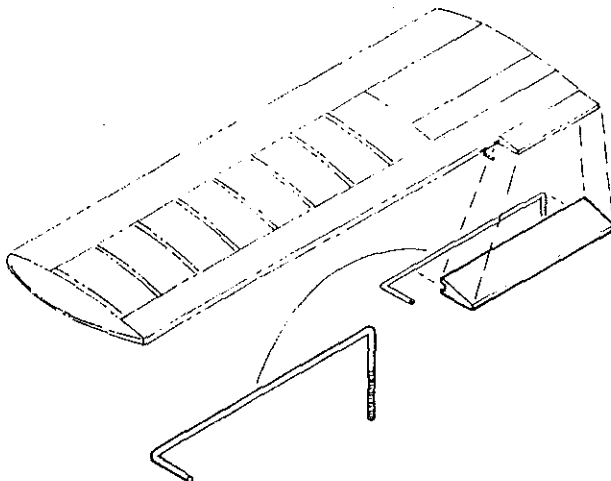

132. Carefully apply Slow CA to the leading edges of the torque rod box. With the torque rod inserted, position the torque rod box on the trailing edge of the wing, as shown on the plan. Hold it in position until the Slow CA cures. The torque rod should pivot freely after the torque rod box is glued in position.

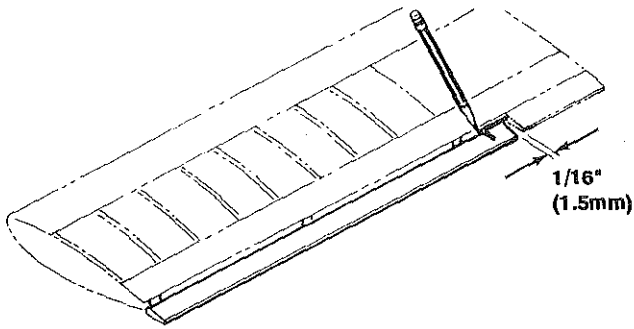

133. Fit one pre-shaped and beveled 1/2" X 1-1/2" X 34" (12.7mm x 38mm x 864mm) balsa aileron against the trailing edge. Leave about a 1/16" gap between the torque rod box and the aileron, as shown on the plan. Mark the location of the torque rod on the aileron.

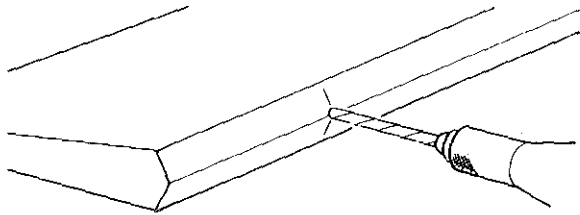

134. Using a 1/8" (3.2mm) drill bit, drill a 7/8" (22.2mm) deep hole into the beveled edge of the aileron at the location you marked for the torque rod, as shown.

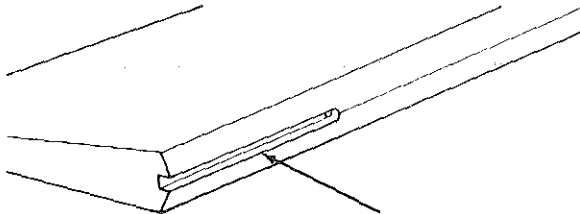

135. Using an X-Acto[®] knife, cut a slot in the aileron between the 1/8" (3.2mm) hole and the edge, as shown. This slot will fit the torque rod, as shown on the plan.

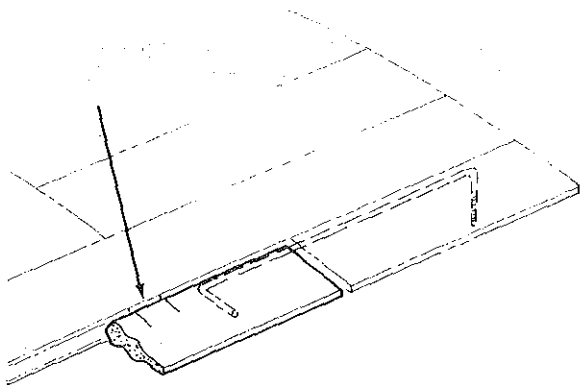

136. Insert the torque rod into the hole in the aileron and push the aileron against the trailing edge of the Wing. Mark the hinge locations on the trailing edge of the Wing and on the aileron.
137. Following the directions for the brand of hinges you are using, install the hinges and fit the aileron to the Wing Panel. Do not glue the hinges in place at this time.

Note: See "Hinge Installation", Page #12.

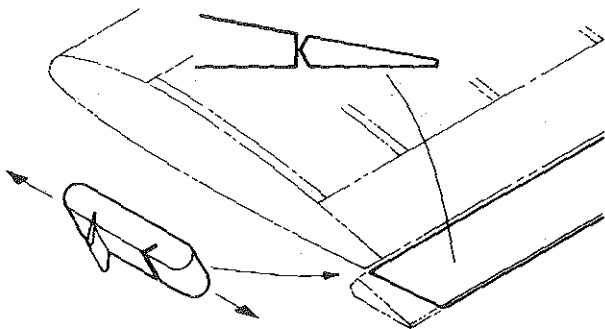

138. Hold the aileron in its neutral position, as shown. Shape the tip of the aileron to match the Wing Tip with a sanding block, as shown on the plan.
139. Remove the aileron and hinges from the Wing Panel.

The Left Wing Panel is now complete. Repeat instructions #101 - #139 to build the right Wing Panel.

Joining The Wing Panels

In this sub-assembly, the Wing Panels will be joined using the pre-cut dihedral brace. This joint will be subjected to heavy loads when the model is flying. For this reason, it will be reinforced with fiberglass cloth.

You will need the following parts to complete this sub-assembly - the dihedral brace in Bag Number Four (4), and the fiberglass cloth in the Wing Hardware Bag.

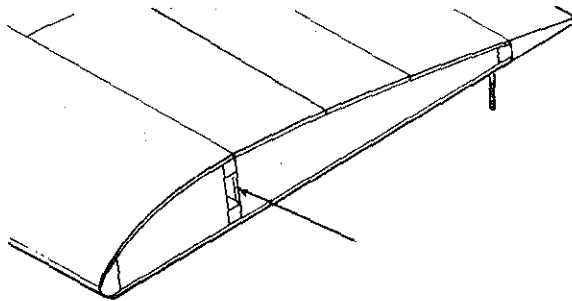
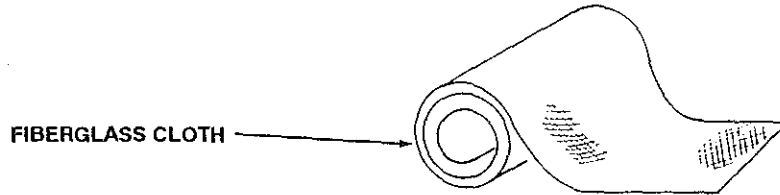

- 140. Using an X-Acto knife, remove the portion of the rib between the spars on both Wing Panels, as shown.

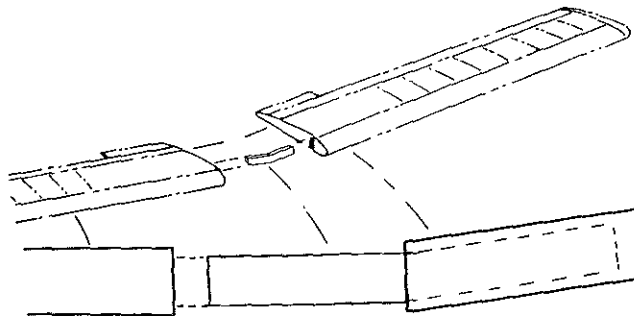

- 141. Insert the dihedral brace into the slot between the spars in both panels and push the panels together.

Note: If the dihedral brace won't slip all the way into the slot, remove it and push a screwdriver into the slot to remove any scraps of wood that might be stopping the dihedral brace.

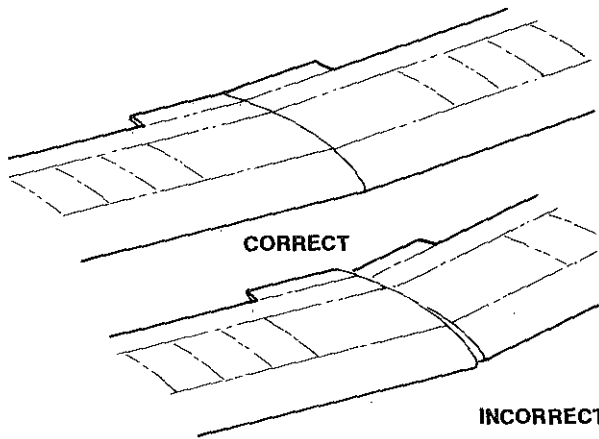

- 142. With the Wing Panels joined by the dihedral brace, align the leading and trailing edges of the panels so their edges are flush with each other at the joint.

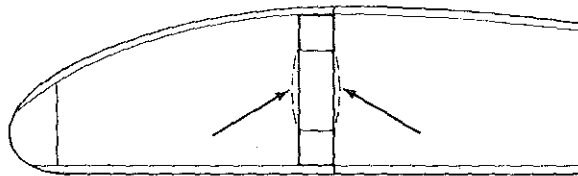

Note: If you have trouble aligning the panels, trim the sides of the slots in the root ribs, as shown.

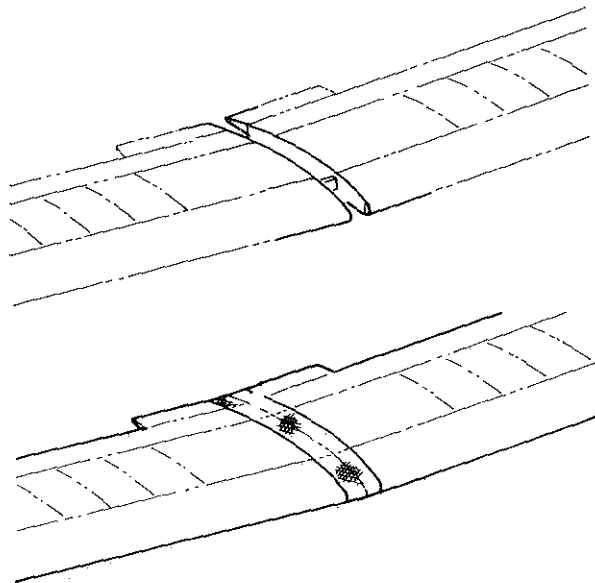

- 143. With the panels joined by the dihedral brace, support the wing as shown in instructions #146. Check the gaps in the joint between the two panels. If necessary, carefully sand the edges of the panels to remove any gaps.

Note: The following instructions, #144 through #146, are to be completed before the epoxy cures.

- 144. Following the directions on the bottles, mix about 2 ounces of slow drying epoxy. Using a stick made from scrap wood, push epoxy into the slots between the spars on both Wing Panels. Apply a thin layer of epoxy to all sides of 1/2 of the dihedral brace and push that half into one Wing Panel. Then, apply a thin layer of epoxy to the root rib and remaining portion of the dihedral brace.
- 145. Join the wing Panels. Remove any excess epoxy with paper towels soaked in alcohol. Then, align the Wing Panels and wrap the joint with masking tape on both sides, as shown.

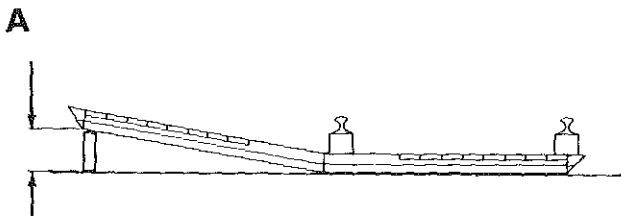

- 146. Lay the Wing on a flat surface. Make a suitable shim from scrap wood. Place the shim under the tip rib on one Wing panel, as shown. Then, place weights on the root and tip of the opposite Wing Panel to hold it down. Let the wing sit in this position until the epoxy cures. Then, remove the masking tape.

Note: Dimension A is not critical. Just be sure the root ribs butt together, flush at the top and bottom.

Caution: Perform instructions #147 and #148 in a well ventilated area to avoid breathing the fumes from the CA.

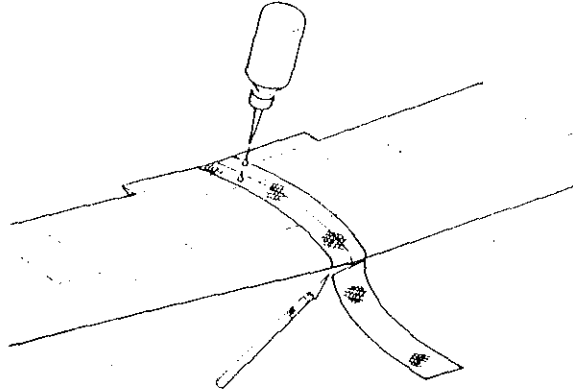

- 147. Center the fiberglass cloth on the upper trailing edge of the Wing. Tack it in position with CA. Then, pull the fiberglass cloth over the top of the Wing and tack it to the leading edge with CA. Cut the cloth off at the leading edge.
- 148. Run CA onto the cloth. Immediately rub the fiberglass cloth down to the wood with a quick circular motion of your finger. Work a small area at a time until the entire piece of fiberglass cloth is bonded to the Wing.

Note: If you do not wish to bond the fiberglass cloth to the wing with CA, mix about 2 oz. of slow curing epoxy and brush it over the fiberglass cloth with a stiff brush. Work the epoxy through the weave of the cloth so that it soaks into the wood.

- 149. Repeat Instructions #147 and #148 to fiberglass the underside of the Wing center section.
- 150. After bonding the fiberglass cloth to the Wing center section, lightly sand the fiberglass cloth with a piece #220 sandpaper to remove any lumps or high spots. Be careful not to sand through the fiberglass cloth or the wood.

Wing Fairing

You will need the four 1/2" x 2-1/8" (12.7mm x 54mm) triangle stock in Bag Number Four (4) and the two 3/8" x 5-11/16" (9.5mm x 144mm) birch wing dowels in Bag Number Three (3) to complete this sub-assembly. You will also need 2 - #64 rubber bands, not supplied with the kit.

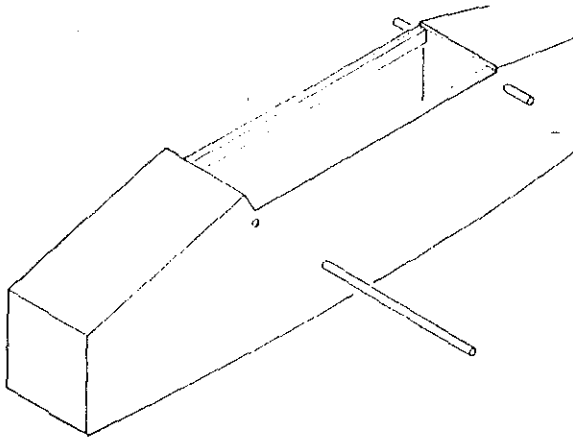

- 151. Temporarily install the two 3/8" x 5-11/16" (9.5mm x 144mm) birch wing dowels in the holes in the Fuselage. Do not glue them in place.

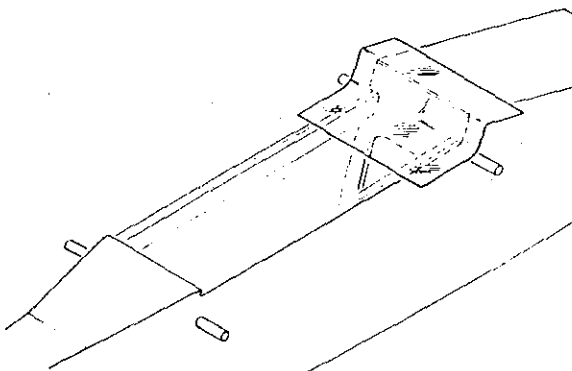

- 152. Lay a piece of plastic wrap across the Wing Saddle. It covers the forward portion of the Saddle and part (2), as shown.

Note: The plastic wrap will prevent accidental bonding of the wing to the Fuselage when you glue the Wing Fairing in place.

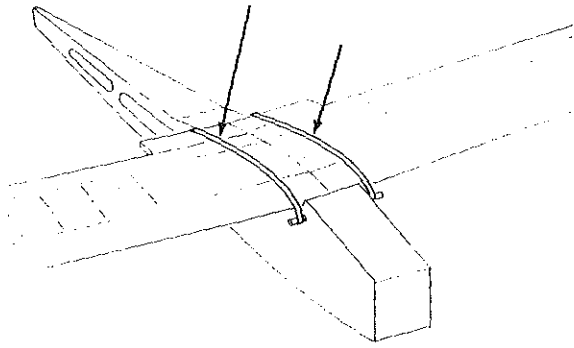

153. Place the Wing on the Wing Saddle. Secure it to the Fuselage with two #64 rubber bands, as shown.

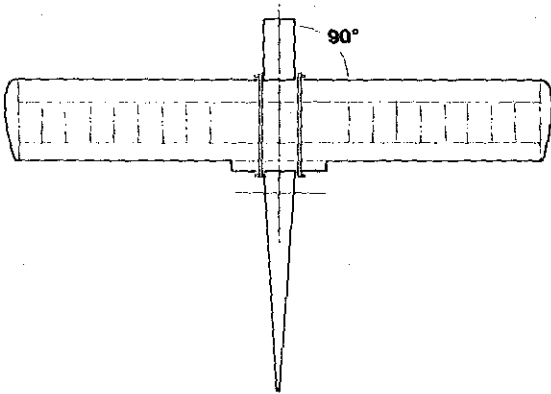

154. Position the Wing on the Wing Saddle so that the joint between the Wing Panels is centered on the Fuselage and the Wing leading edge is butted against part two (2). Look at the Wing and Fuselage from above. Align the wing square to the Fuselage, as shown.

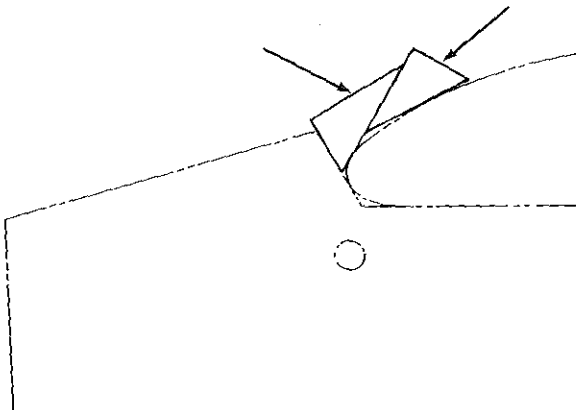

155. Study the drawing of the Wing Fairing in the Fuselage Side View on the plan. Note how the triangle stock is positioned to build the fairing.

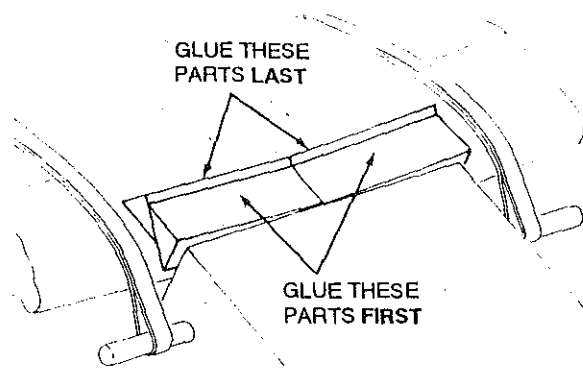

- 156. Using Slow CA, glue the four pieces of 1/2" x 2-1/8" (12.7mm x 54mm) triangle stock to the leading edge of the Wing in the order shown on the illustration at the left. Align each piece so that one edge is located over the joint in the Wing Panels.

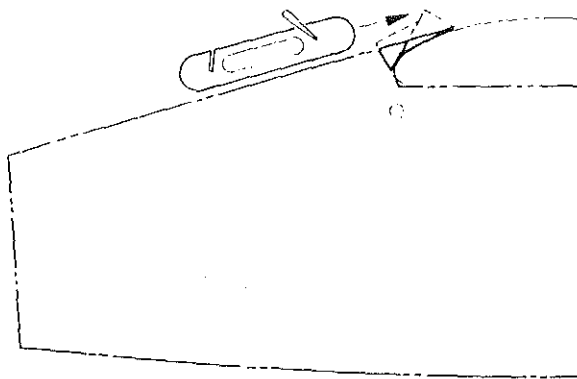

- 157. Using a sanding block, sand the Wing Fairing flush with the top of part twelve (12) on the Fuselage.

Note: After sanding the fairing, you may have a slight step between the back of the fairing and the top of the Wing. If you are going to finish your Aero-Star with an iron-on covering, such as Monokote, nothing needs to be done with this step. However, if you are going to finish your model with paint, this step will need to be filled. Your hobby dealer can suggest an appropriate wood filler for the type of paint you decide to use.

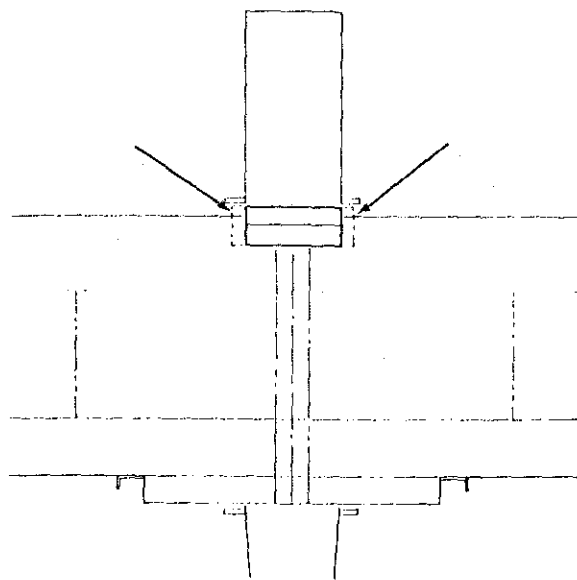

- 158. If necessary, use an X-Acto knife to trim both edges of the fairing flush with the sides of the Fuselage. Be careful not to cut into the Wing.

The Wing is now complete. Remove it, and the Wing Dowels, from the Fuselage.

Engine and Cowl

In this section, the Engine will be fitted to the Motor Mount and Cowl will be glued in place.

Note: The following instructions are the same for both 2-Cycle and 4-Cycle Engine and Cowl installations. A 4-Cycle Engine installation is shown on the Fuselage plan sheet.

Engine Installation

You will need the two 24" (610mm) nylon pushrod tubes and four 6-32 x 3/4" (6-32 x 19mm) bolts in the fuselage Hardware Bag to complete this assembly. You will also need an engine and spinner, not supplied with the kit.

In addition, you will need the four 6-32 x 1" (6-32 x 25.4mm) bolts and nylon motor mount used to construct the Firewall.

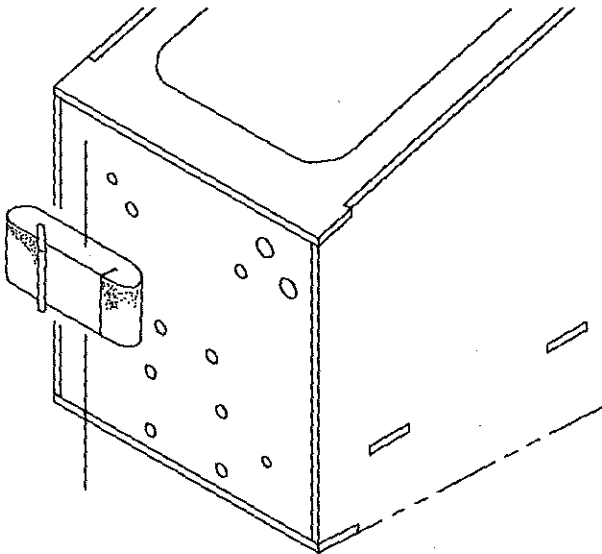

- 159. Using a sanding block, sand the front edges of the Fuselage flush with the front of the Firewall. Be careful to lay the sanding block flat on the Firewall while sanding to prevent rounding the corners and edges of the fuselage.

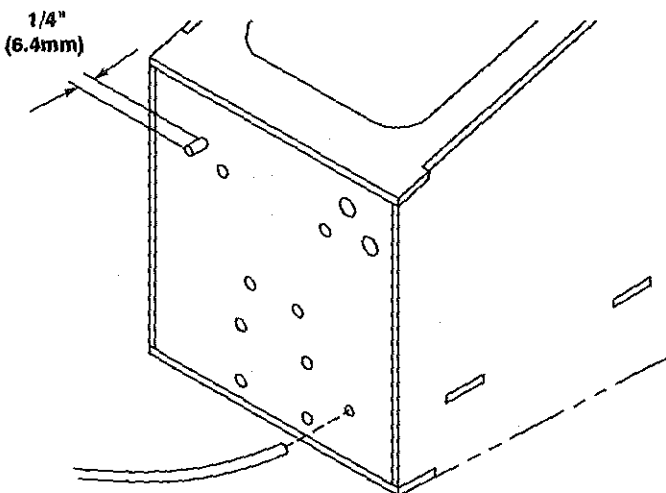

- 160. Slip one 1/8" x 24" (3.2mm x 610mm) nylon tube into the throttle hole in the Firewall, as shown. Push it into the hole until about 1/4" (6.4mm) protrudes through the front side of the Firewall. Secure it with CA.
- 161. Slip one 1/8" x 24" (3.2mm x 610mm) nylon tube into the Nose Gear steering hole in the Firewall, as shown. Push it into the hole until about 1/4" (6.4mm) protrudes through the front side of the Firewall. Secure it with CA.

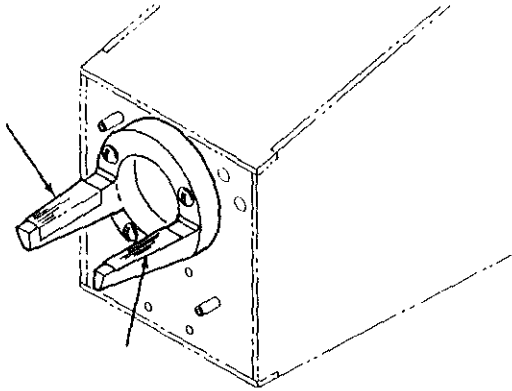

- 162. Use strips of masking tape to temporarily secure the tubes to the fuselage sides, while work further progresses. This tape is removed after installing the throttle and nosegear pushrods.
- 163. Attach the Motor Mount to the Firewall with four 6-32 x 1" (6-32 x 25.4mm) bolts, as shown.
- 164. Attach a strip of masking tape to the top side of each Motor Mount beam, as shown.

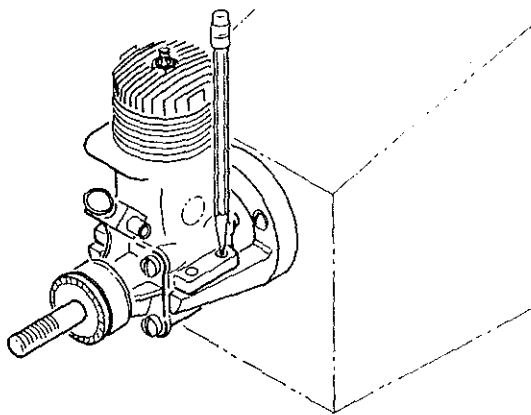

- 165. Sharpen the point of a pencil so it will go through the holes in the Engine's mounting plates.
- 166. Position your Engine on the Motor Mount so that both mounting plates sit flat on the Motor Mount beams and there is enough clearance between the Engine and the backplate of the Motor Mount to allow the fuel lines to pass between them. (The Fuselage Plan shows the relationship of these parts.)
- 167. Hold the Engine securely to the Motor Mount. Insert the pencil point in each of the bolt holes in the Engine's Mounting Plates and mark the locations of the holes on the masking tape.

Note: If the Engine is a tight fit on the Motor Mount, it will self-align with 0° right thrust. This is OK. However, if your engine is a loose fit on the Motor Mount, it may be possible to pivot the engine left and right. If this is the case, position the Engine so it is pivoted towards the right side. This will result in the Engine having some right thrust. In no case should the engine be installed with left thrust.

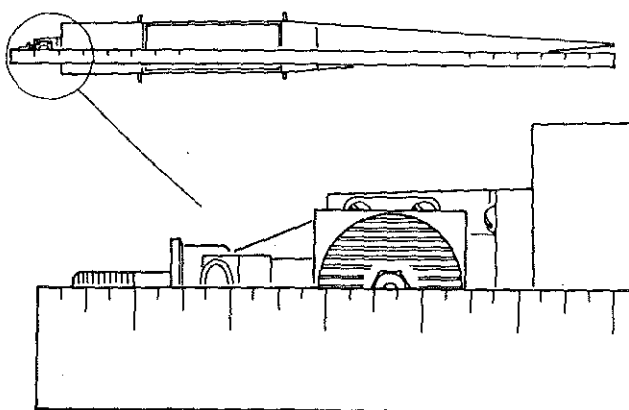

- 168. To check the thrush line of the Engine, hold a 48" (1219mm) straight edge over the top of the Engine so it is centered over the prop shaft and the tip of the glow plug. The opposite end of the straight edge should be either in line with the back end of the Fuselage, or in the case of right thrust, run off the left side of the Fuselage at the back end, as shown.

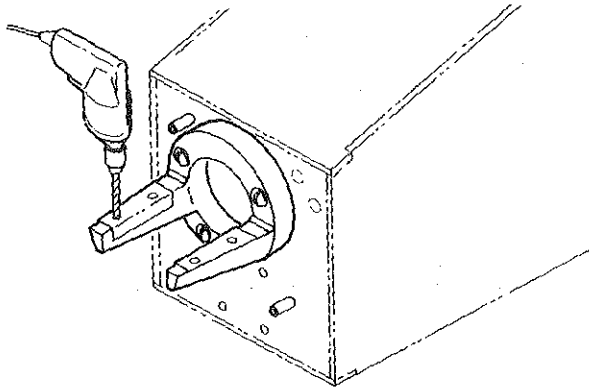

- 169. Remove the Engine from the Motor Mount. Drill vertically through the Motor Mount, on the pencil marks, with a 3/32" (2.3mm) drill bit.

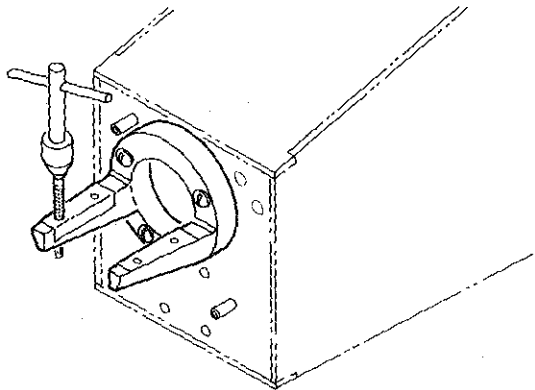

- 170. Turn a 6-32 tap, by hand, through each hole to thread the holes.

Note: If you have never used a tap, the procedure is quite simple. Turn the tap clockwise into the hole. When resistance is met, or every two revolutions, back the tap out 1/2 turn. This will clear the cutting points on the tap. Continue this process until the tap comes through the bottom of the hole. Do not use thread cutting oil when threading the Motor Mount.

- 171. Remove the masking tape and position the Engine on the Motor Mount. Secure it with four 6-32 x 3/4" (6-32 x 19mm) bolts.

Note: At this time, we recommend that you cover the exhaust port and carburetor of your Engine with a piece of plastic wrap, securing it with a rubber band. This will prevent balsa shavings from getting into, and possibly damaging, the Engine.

Cowl Installation

You will need the parts illustrated below to complete this sub-assembly. They are in Bag Number Three (3).

1/2" (12.7mm) BALSA COWL BLOCKS

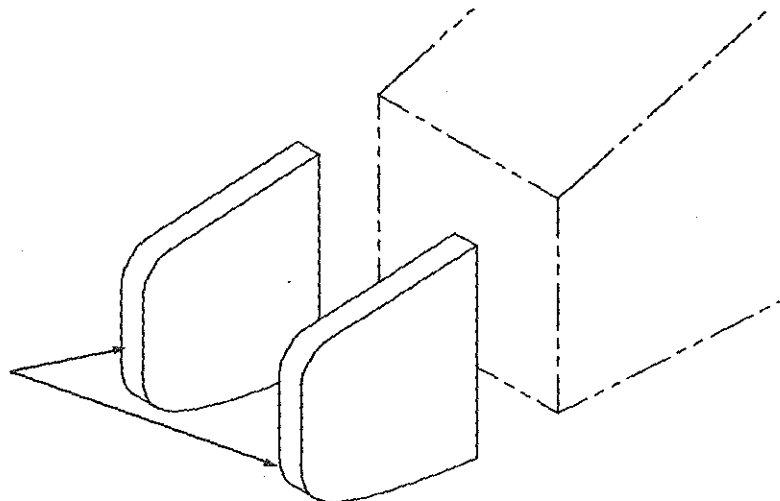

1/8" (3.2mm)

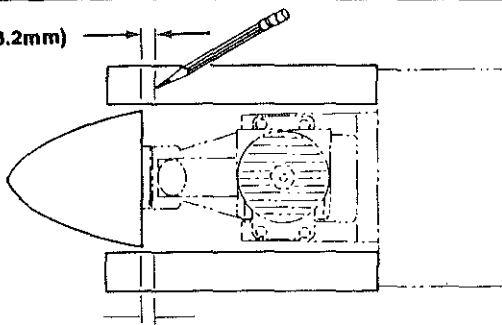

- 172. If you intend using a Spinner, attach it securely to the prop shaft. Fit one 1/2" x 4-11/32" x 4-1/8" (12.7mm x 110mm x 105mm) balsa cowl block to each side of the Fuselage, on the front of the firewall, as shown.
- 173. Make a pencil mark 1/8" (2.3mm) behind the back edge of the Spinner on each block, as shown.

1/4" (6.4mm)

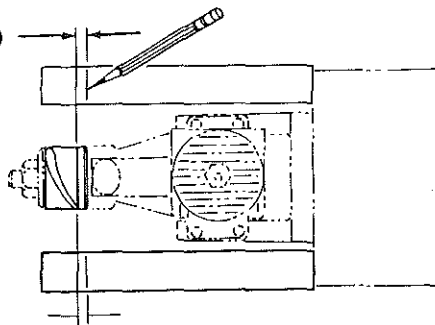

Note: If you do not intend using a spinner, attach the propeller to the engine and make a pencil mark 1/4" (6.4mm) behind the front edge of the rear prop washer, as shown.

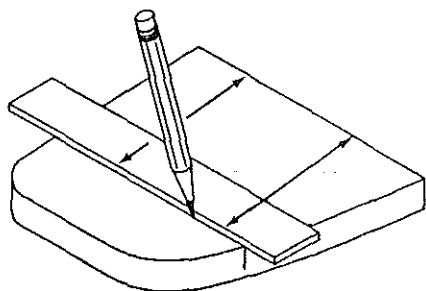

- 174. Using a straight edge, draw a line through the pencil mark, parallel to the back edge of each cowl block, as shown.
- 175. Using a straight edge to guide your X-Acto[®] knife, cut through each block on the pencil line.

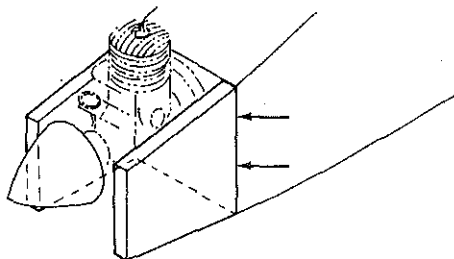

- 176. If necessary, pre-glue the end grain of each block that will contact the Firewall. Apply Slow CA to the end of each block and install the blocks on the Firewall so they are flush with, and parallel to, the Fuselage sides, as shown on the Fuselage Plan.

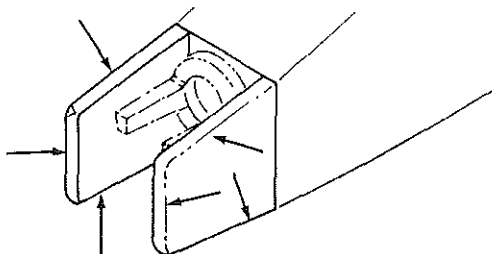

- 177. Remove the Engine from the Motor Mount. Leave the Motor Mount attached to the Firewall.
- 178. Using a sanding block, sand the corners and outside edges of the cowl blocks to a round section, fairing them into the Fuselage Sides, as shown here and on the plan.

The Cowl is now complete.

Landing Gear

At this point, the Main Gear Block has already been installed and the Nose Gear Bearing Block has been fitted. All that remains is to fit the Landing Gear Legs and Wheels.

Main Gear

You will need the parts illustrated below to complete this sub-assembly. The Landing Gear Cover Plate is in Bag Number Three (3). All other parts are in the Fuselage Hardware Bag.

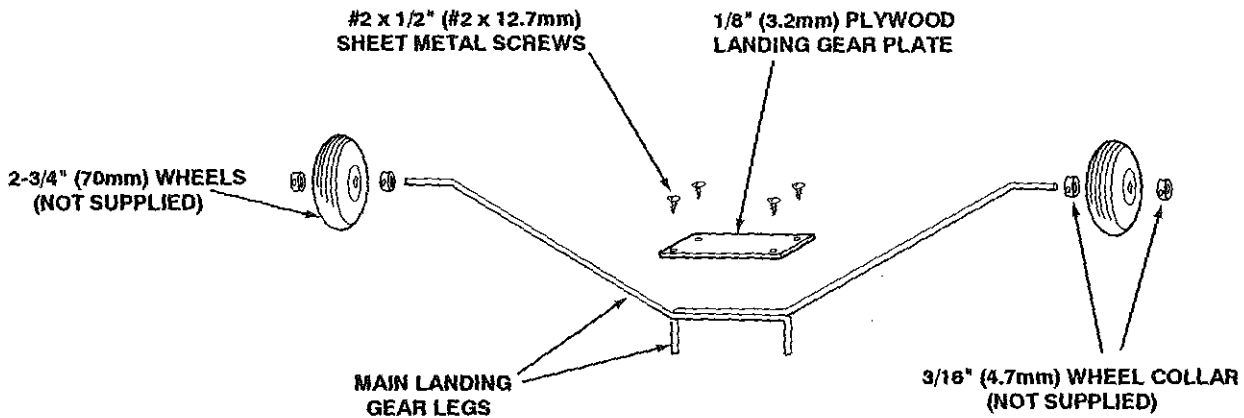

You will also need the following parts not supplied with the kit: 4 - 3/16" (4.7mm) Wheel Collars and 2 - 2-3/4" (70mm) Wheels.

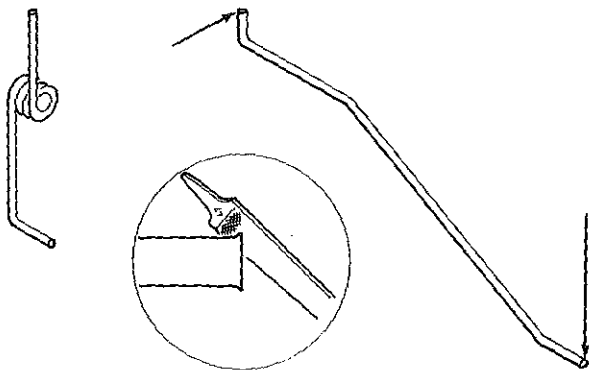

- 179. Inspect both ends of the Main Gear Legs for burrs or rough edges. If any are found, use a flat file to remove them.

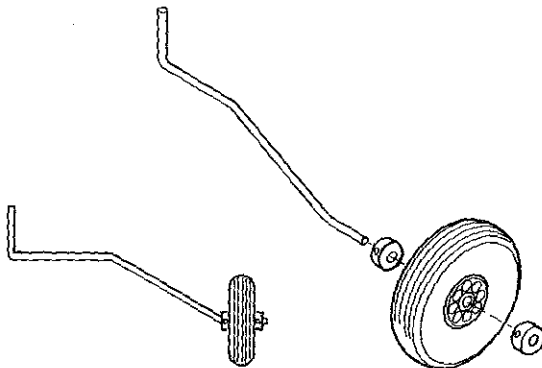

- 180. Install one 2-3/4" (70mm) wheel and two 3/16" (4.7mm) wheel collars on the axles of each main landing gear leg, as shown. The inside collar should be positioned all the way to the inside of the axle. Then, tighten the collars, allowing the wheels to turn freely on the axles, but preventing them from moving sideways.

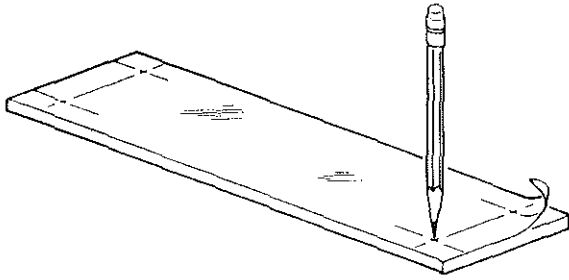

- 181. Cut the Landing Gear Cover Plate template from the plan. Align it on the plywood Landing Gear Cover Plate and mark the four hole locations on the plywood by pushing a pencil point through the template at the intersection of each of the crosses on the template.

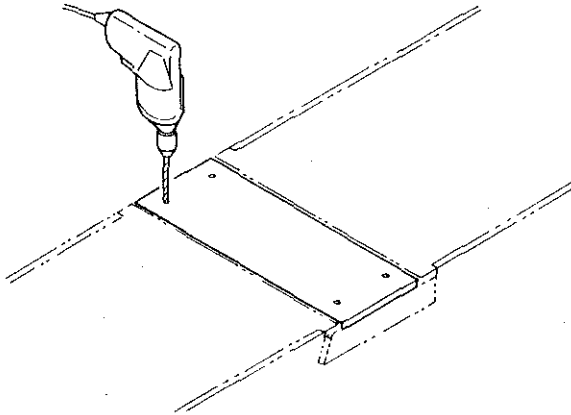

- 182. Position the Landing Gear Cover Plate on the Landing Gear Block. If necessary, sand the long edges of the cover plate to allow it to seat down between the bottom Fuselage sheeting, as shown. Drill through the cover plate and the Gear Block with a 1/16" (1.5mm) drill bit.

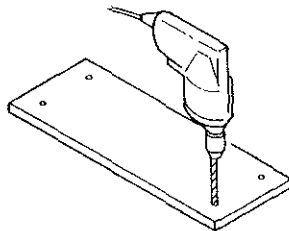

- 183. Remove the cover plate from the Landing Gear Block and drill through the four holes with a 3/32" (2.3mm) drill bit.

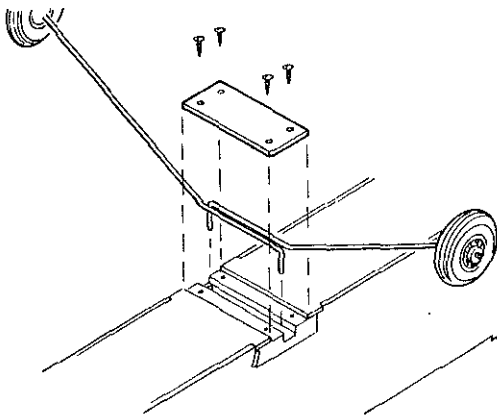

- 184. Insert the Main Landing Gear Legs into the pre-drilled holes and slots in the Main Gear Block, as shown. Position the cover plate on the Main Gear Block and secure it with four #2 X 1/2" (#2 x 12.7mm) sheet metal screws, as shown.

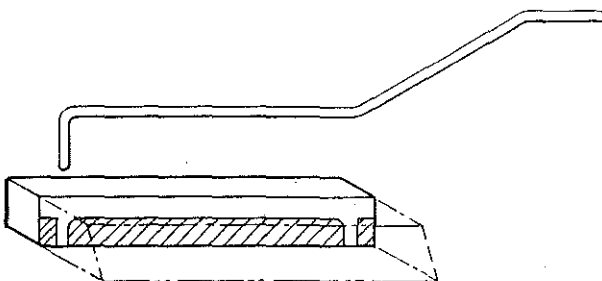

Note: If the Main Landing Gear Legs won't slip all the way into the holes in the Gear Block, run a 3/16" (4.7mm) drill bit into the holes to clear any obstructions. Try not to drill through the Servo Rails that sit over these holes on the Torque Blocks. It may also be necessary to cut a radius into the holes in the Main Landing Gear Block with an X-Acto[®] knife, as shown. This will allow the 90° bends in the Main Gear legs to lay flat on the gear block.

The Main Landing Gear installation is now complete.

Nose Gear

You will need the parts illustrated below to complete this sub-assembly. All of these parts are in the Fuselage Hardware Bag.

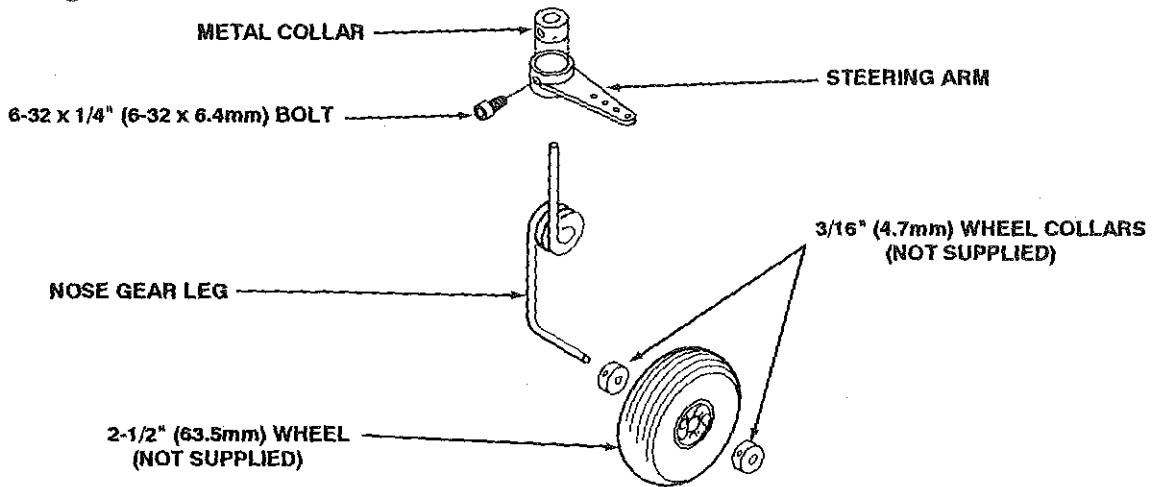

You will also need the following parts, not supplied with the kit: 2 - 3/16" (4.7mm) wheel collars and 1 - 2-1/2" (63.5mm) wheel.

In addition, you will also need the four 6-32 x 1/2" (6-32 x 12.7mm) bolts and the Nose Gear bearing block used to construct the Firewall.

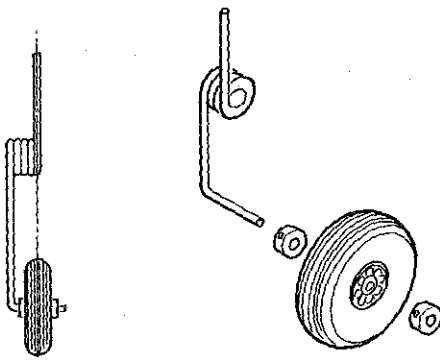

- 185. Place the 2-1/2" (63.5mm) wheel and two wheel collars on the Nose Gear axle. Hold the collars against each side of the wheel and center the wheel on the Nose Gear Leg, as shown. Then, tighten the collars, allowing the Wheel to turn freely on the axle, but preventing it from moving sideways.

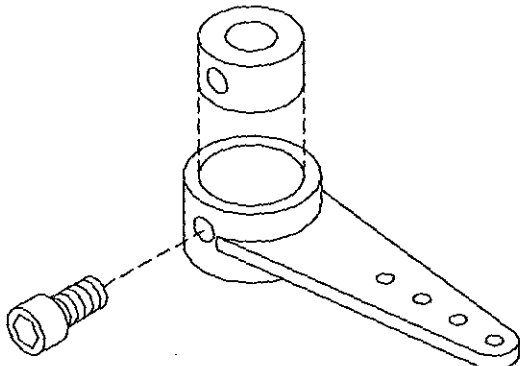

- 186. Insert the 3/16" (4.7mm) metal collar into the Steering Arm. Align the holes in the two parts and screw the 6-32 x 1/4" (6.4mm) bolt into the arm and collar, as shown. Do not tighten the bolt.

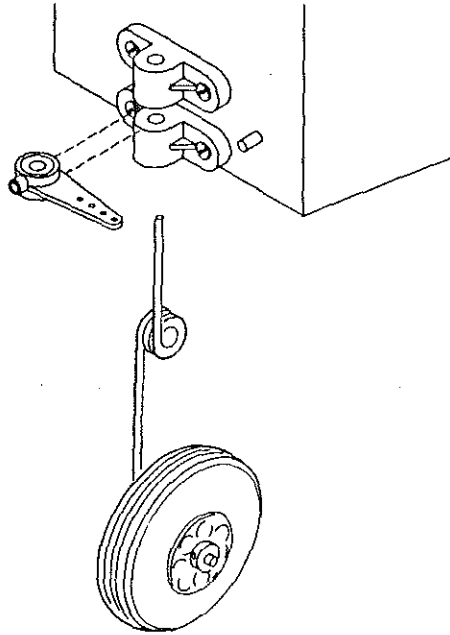

- 187. Secure the Nose Gear Bearing Block to the Firewall with four 6-32 x 1/2" (6-32 x 12.7mm) bolts. Position the Steering Arm in the slot in the Nose Gear Bearing Block with the arm on the same side as the nylon tube, as shown. Insert the Nose Gear into the Nose Gear Bearing Block and through the steering arm. Push it up until it stops against the bottom of the Motor Mount. Align the Nose Wheel so it is straight. Position the steering arm as shown on the Fuselage Top View on the plan and then tighten the bolt on the steering arm.

- 188. Remove the cover plate, Main Landing Gear, Nose Gear and steering arm from the Fuselage. Place these parts, and the bolts that attach them aside. Leave the Motor Mount and Nose Gear Bearing Block attached to the Firewall.

Note: It may seem redundant to assemble parts for fitting and then remove them. However, this eases other portions of the model's construction.

Tail Section Installation

In this section, the Stabilizer and Fin will be fitted and glued to the Fuselage. To insure your Acro-Star's self-saving ability, careful attention should be paid to aligning these parts on the Fuselage.

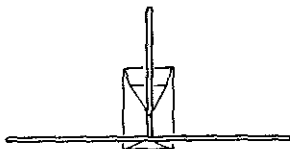

CORRECT

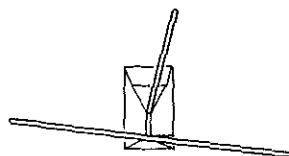

INCORRECT

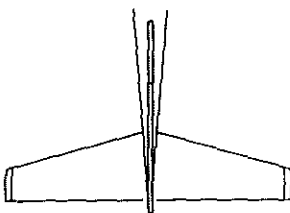

CORRECT

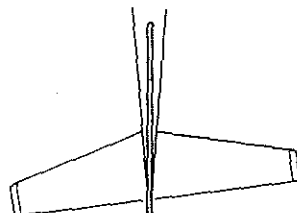

INCORRECT

In the case of the Tail Section, aligned means that the parts are square, both horizontally and vertically, in relation to the Fuselage centerline; and that they are centered on the Fuselage, as shown.

Stabilizer

You will need the previously built Stabilizer to complete this sub-assembly. The Elevator will not be needed at this time.

You will also need 1 - 3/8" Dia. x 23" (9.5mm Dia. x 584mm) Birch Pushrod from Bag Number Three (3).

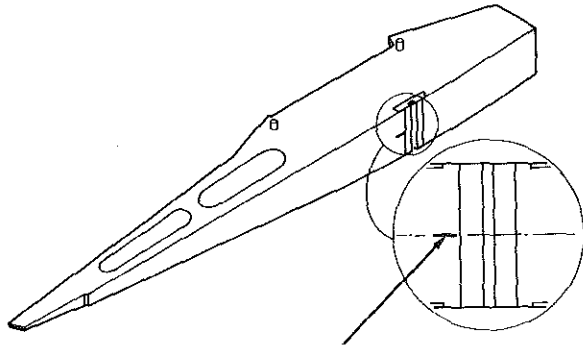

- 189. Using a ruler and pencil, make a pencil mark on the bottom of the Fuselage, at the CENTER of the front edge of part nine (9), as shown.

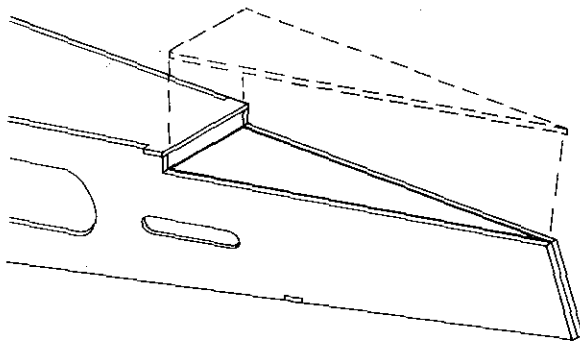

- 190. Glue the Stabilizer Platform to the inside of the Stabilizer Saddle, flush with the inside edges of the Fuselage, as shown.

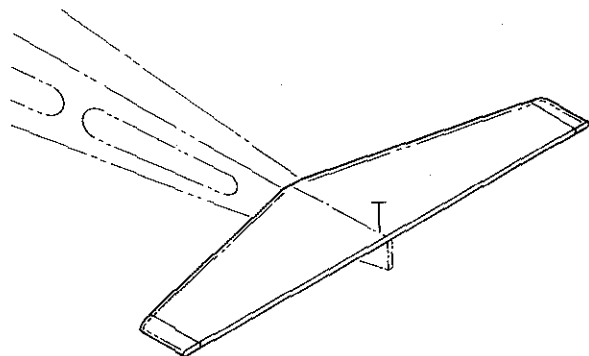
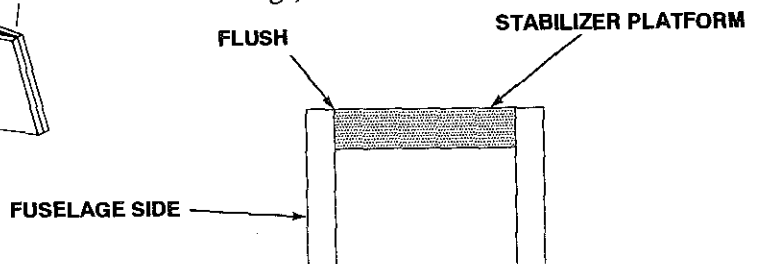

- 191. Remove the Elevator from the Stabilizer. Lay the Stabilizer in the Stabilizer Saddle. Align the centerline that you marked on the Stabilizer over the Tailpost. Secure the trailing edge of the Stabilizer with one t-pin, as shown.

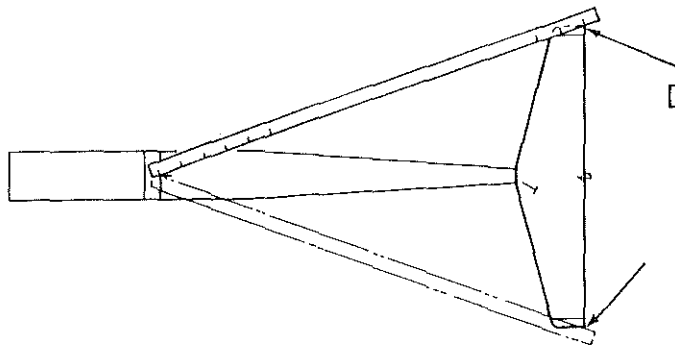

- 192. Using a 48" (1219mm) straight edge, measure the distance between the pencil mark and both tips of the Stabilizer, as shown. Pivot the Stabilizer, as shown, until the measurements at both tips are the same. Then, push a t-pin through the Stabilizer into the Fuselage as shown, to secure it.

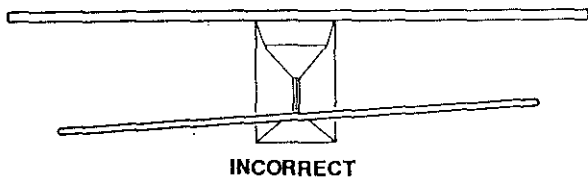
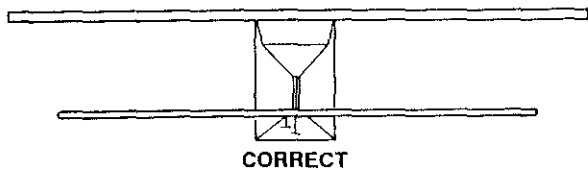

- 193. Lay the 3/8" Dia. x 23" (9.5mm Dia. x 584mm) Birch Pushrod squarely across the Wing Saddle, as shown. Sight down the Fuselage from the rear while pressing the Stabilizer into contact with both sides of the Saddle. If the Stabilizer is not parallel to the Pushrod, remove the Stabilizer and lightly sand the high side of the Saddle with a sanding block. Check the fit of the Stabilizer frequently while doing this until it is parallel to the Pushrod, as shown.

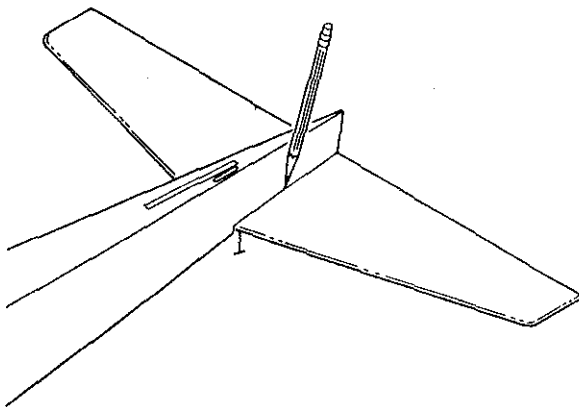

- 194. When the Stabilizer is properly aligned, lightly mark its exact position on the Fuselage with a pencil, as shown.
- 195. Remove the Stabilizer from the Fuselage. Apply Slow CA to the Stabilizer Saddle and, using the pencil marks and centerline as a guide, bond the Stabilizer to the fuselage.

Fin

You will need the previously built Fin and Rudder to complete this sub-assembly. You will also need the two tail skid parts in Bag Number Three (3).

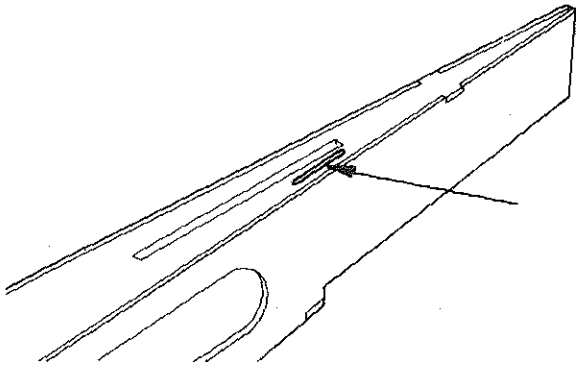

- 196. Using an X-Acto[®] knife, carefully remove the wood inside of the indented lines on part seven (7). The resulting slot will be used later as the Rudder Pushrod exit.

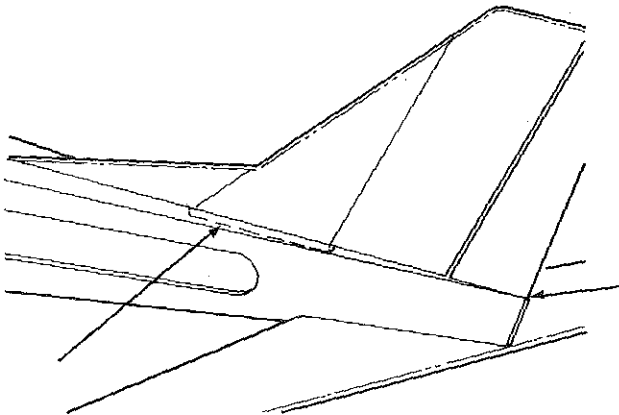

- 197. With the Fin and Rudder temporarily joined by the hinges, fit the alignment tab on the bottom of the Fin into the slot in the top of part seven (7). Slide the Fin backward, or forward, to align the trailing edge of the Rudder with the Tailpost, as shown.
- 198. Check to be sure that the Fin is in contact with part seven (7) along its entire length. If necessary, use a sanding block to carefully trim the bottom of the Fin for a good joint.

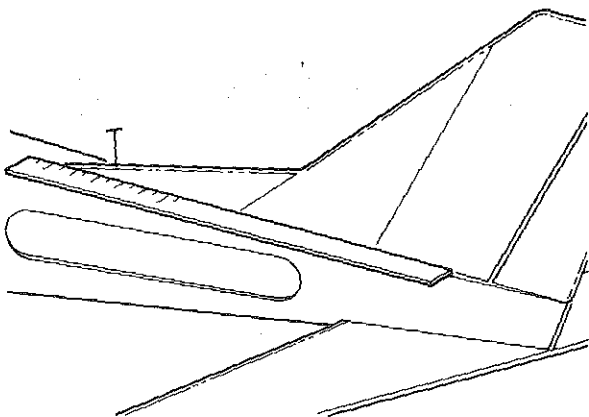

- 199. Lay a straight edge on part seven (7) against the side of the fin and pull the Dorsal Fin into contact with the straight edge. Then, push a t-pin through the Dorsal Fin and into part seven (7), as shown, to hold it straight.

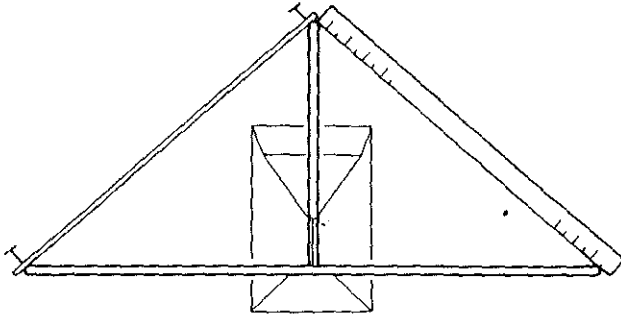

- 200. Pin a piece of scrap wood to the tip of the Stabilizer, as shown. Hold the other end of the scrap against the top of the Fin and measure the distance from the top of the Fin to both Stabilizer tips. When the two measurements are the same, pin the scrap wood to the top of the Fin, as shown, to hold it in position.
- 201. Press the Fin into contact with part seven (7) and apply CA to the joint between part seven (7) and the Fin. After gluing, remove the pins and scrap wood.

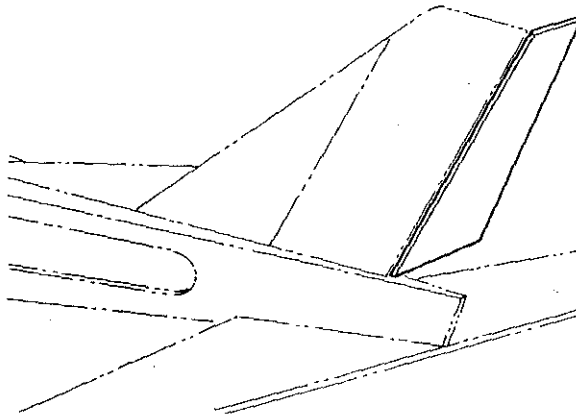

Note: Because of the angle created by the trailing edge of the fin and part seven (7), it will be necessary to deflect the Rudder, as shown, to remove it from the Fin. If your hinges fit deeply into the Fin and Rudder, it may also be necessary to pull the top of the Rudder out of the Fin first and then wiggle the bottom portion out. Keep this in mind. You will have to remove and re-install the Rudder at a later time.

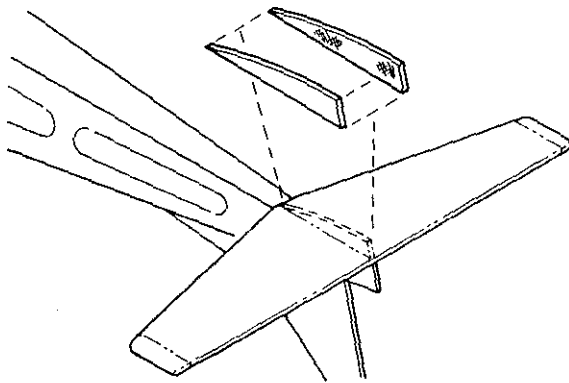

- 202. Glue the two Tailskid parts together with Slow CA, as shown. After joining the parts, use a sanding block to sand the edges flush. Then, apply Slow CA to the Tailskid and glue it to the Stabilizer. Center it on the centerline, aligning its rear edge with the Tailpost, as shown.

Note: If you intend finishing your Aero-Star with Monokote, we recommend that you do not glue the Tailskid to the Stabilizer at this time. This will make covering these parts easier.

Control Linkages

In this section, your radio's servos and the Aero-Star's tail horns and pushrods will be installed.

Note: Before starting this section, charge your radio's batteries, following the manufacturer's instruction. While waiting for the batteries to charge, read through the servo, tail horn and pushrod sub-assemblies in this section. Also, study the radio and pushrod installation of the plans to become familiar with all of the parts and how they relate to each other.

Servos

If any of the following servo installation instructions contradict your radio manufacturer's instructions, follow the radio manufacturer's instructions for mounting the servos on the servo tray. However, follow the instructions below for positioning the servo tray on the servo rails.

Most radios come with several servo trays. These trays hold the servos, that are mounted in the Fuselage, in various configurations. The Fuselage Plan shows a configuration called a 2 + 1 servo tray. With a little thought, servo trays having other configurations can also be used on the the Aero-Star. If your radio did not come with servo trays, chances are your hobby dealer can supply you with one that will fit your servos. If not, a servo tray can be made from a sheet of 1/4" (6.4mm) aircraft plywood cut to the size of the tray shown on the plans. The servos can be screwed to the tray with small sheet metal screws. Your hobby dealer should have these items.

The aileron servo in the Wing will be mounted on two pre-cut plywood parts supplied with the kit. No servo tray is necessary for this installation.

You will need the following parts to complete this sub-assembly - 2 - 1/4" x 3/8" x 3-31/32" (6.4mm x 9.5mm x 101mm) plywood servo supports in Bag Number Three (3) and 2 - 1/4" x 3/8" x 1-1/2" (6.4mm x 9.5mm x 38mm) plywood aileron servo rails from Bag Number Four (4).

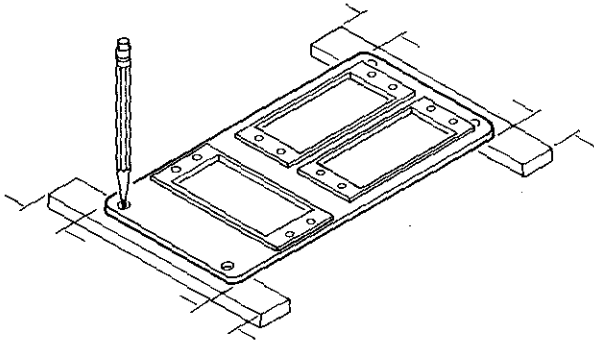

- 203. Study the Fuselage Plan, noting the positions of the servos on the servo tray.
- 204. Position the two 1/4" x 3/8" x 3-31/32" (6.4mm x 9.5mm x 101mm) plywood servo supports under the mounting holes in your servo tray, as shown. Center the servo supports so that an equal amount of both ends on each support stick out from the sides of the servo tray, as shown. Then, mark the mounting hole locations on each servo support.

Note: If rubber grommets are used in the mounting holes on your servo tray, be sure they are installed before working on this step.

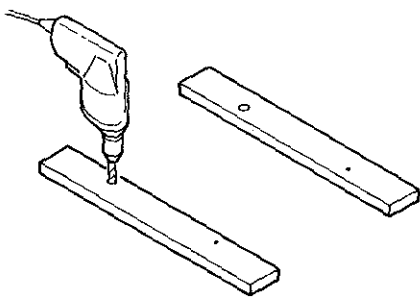

- 205. Using a drill bit of the right size (usually a 1/16" (1.5mm)), drill through the servo supports at the pencil marks.

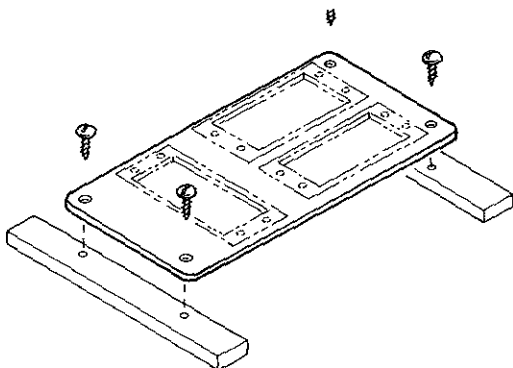

- 206. Using the mounting screws that came with your radio, attach the servo supports to the servo tray.

Note: Not all radios come with these mounting screws. If this is the case with your radio, you can use #2 x 1/2" (#2 x 12.7mm) sheet metal screws to mount the servo tray on the servo supports. These screws can be purchased at most hobby shops.

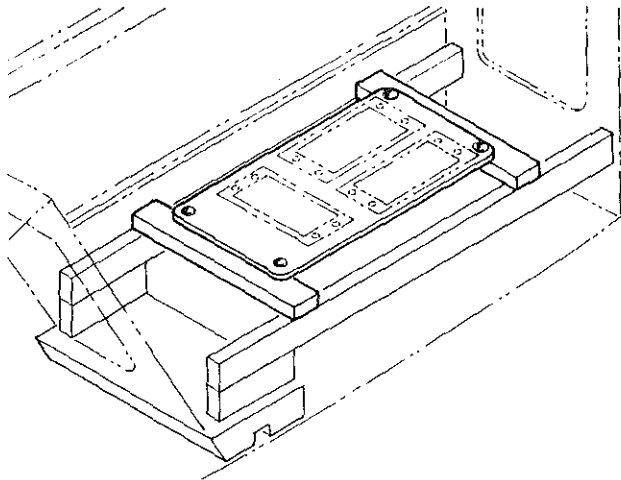

- 207. Lay this assembly on the servo rails in the Fuselage. Position the servo tray at the location shown on the plans. Mark its location with a pencil. Then apply Slow CA to the bottoms of the servo supports and press them into position on the servo rails, as shown. Be sure the servo tray faces the right way.

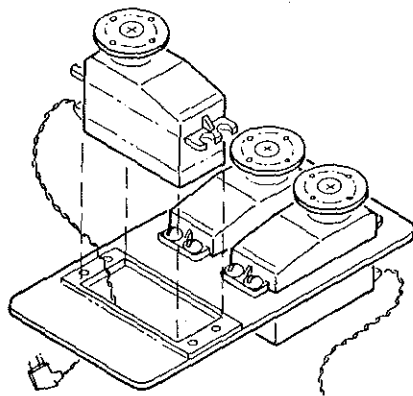

- 208. Remove the servo tray from the Fuselage. Following the radio manufacturer's directions, mount three servos in the servo tray, using the plan as a guide. Note which way each servo faces on the tray. Then, reinstall the servo tray on the servo supports.

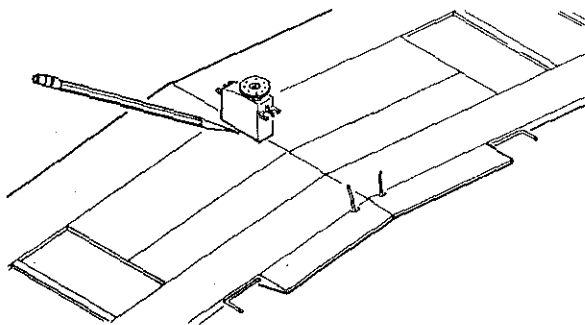

- 209. Lay the aileron servo on the underside of the Wing, as shown. Position it where shown on the plan. Then draw a pencil line around the base of the servo.

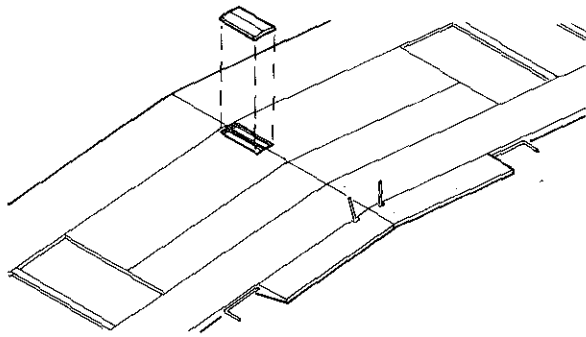

- 210. Using a straight edge and a sharp X-Acto[®] knife, carefully cut through the balsa Wing Sheeting along the pencil lines. Remove the cut off balsa sheeting by peeling it away from the center ribs.

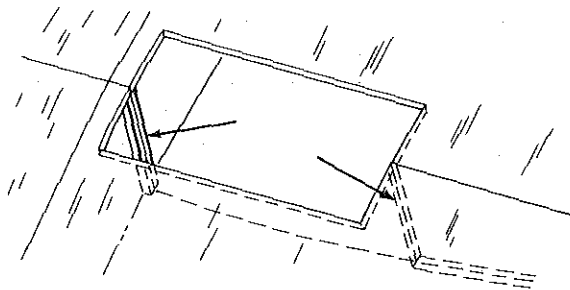

- 211. Slice through the root ribs, as shown. Remove the cut away portions of the root ribs by grabbing them with a pair of pliers and twisting them free.
- 212. Trim off and remove any scraps of balsa that remain on the edges of the root ribs.

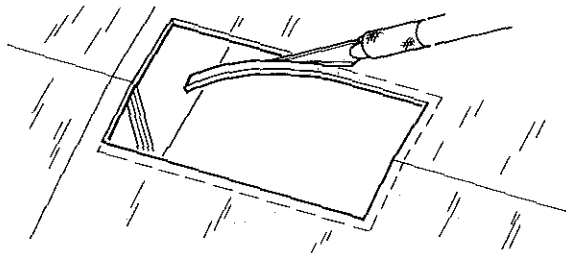

- 213. Enlarge the edges of the hole and cut away the edges of the root ribs so that, with the servo sitting in the hole, it will clear all of the edges by about 1/8" (3.2mm).

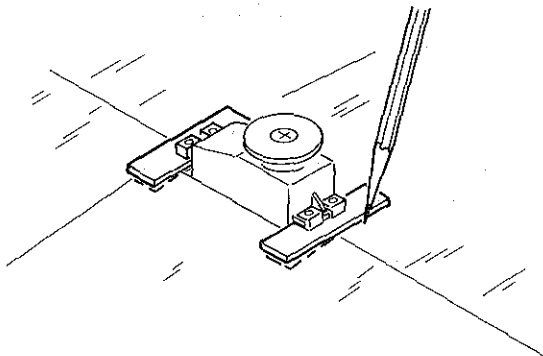

- 214. With the aileron servo centered in the hole, position the two 1/4" x 3/8" x 1-1/2" (6.4mm x 9.5mm x 38mm) plywood servo rails as shown. Align them so that the servo's mounting holes are over each servo rail. Then, mark the location of each servo rail on the Wing Sheeting.

Note: Be sure the rubber grommets are installed on the aileron servo when working on this step.

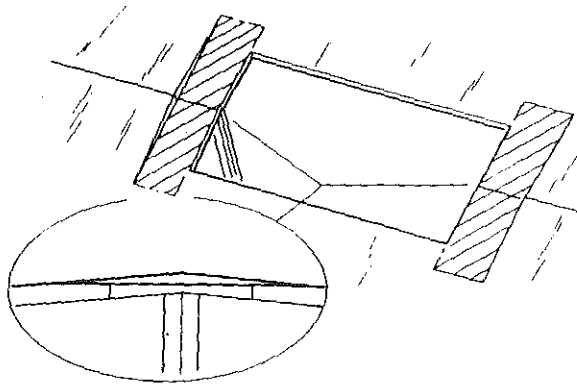

- 215. Remove the servo and servo rails from the wing. Using an X-Acto knife, carefully scrape the wing Sheeting that will be covered by the servo rails until those area are flat, as shown.
- 216. Using Slow CA, glue the servo rails in position on the Wing Sheeting.

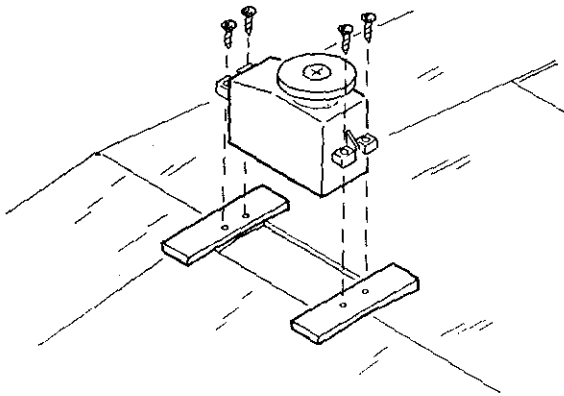

- 217. Again center the aileron servo in the hole and on the servo rails. Mark the mounting hole locations with a sharp pencil. Remove the servo and drill through the servo rails with a 1/16" (1.5mm) drill bit. Then, fasten the servo to the servo rails with the screws provided with the servo.

Control Horns

You will need the parts illustrated below to complete this sub-assembly. They are located in the Fuselage Hardware Bag.

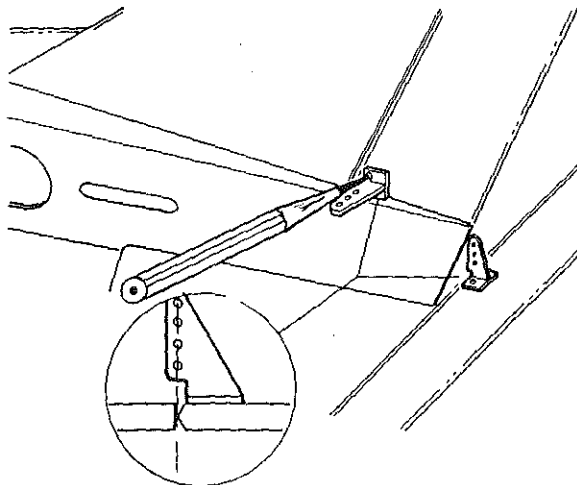
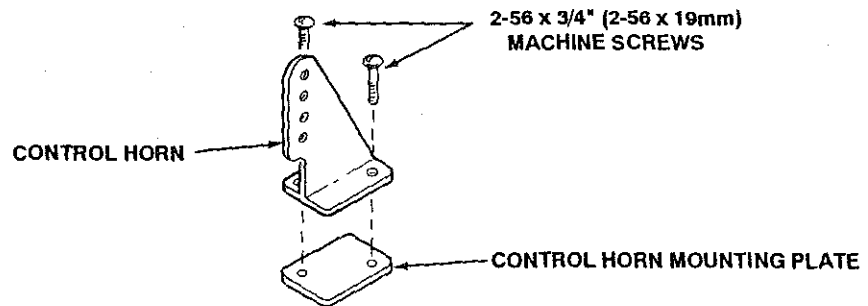

- 218. Use the hinges to temporarily attach the Rudder to the Fin and the Elevator to the Stabilizer. Do not glue the hinges in place at this time.
- 219. Position a control horn on the Rudder and on the Elevator at the locations shown on the plan. Mark the locations of the mounting holes on the Rudder and Elevator with the point of a sharp pencil, as shown.

Note: When positioning the control horns, be sure the pushrod attachment holes are in line with the hinge line of the control surface, as shown.

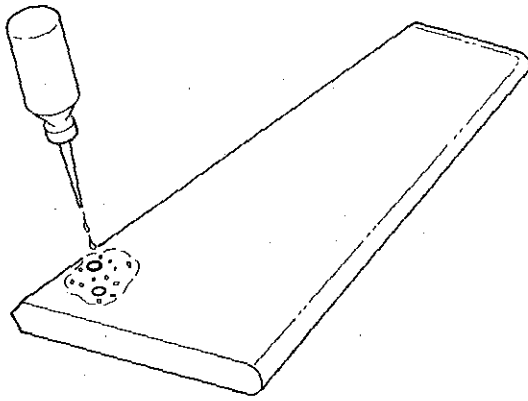

- 220. Remove the Rudder and Elevator from the Stabilizer and Fin. Drill through the pencil marks with a $3/32$ " (2.3mm) drill bit. Then, punch pin holes half way through both sides of the control surfaces in the area of the drilled holes, as shown.
- 221. Remove any hinges that are within two inches of the drilled holes. Then, flow CA onto the areas that have the pin holes in them. Allow the CA to soak into the drilled holes and into the pin holes.

Note: The CA will harden the interior of the balsa. This will prevent the control horns from crushing the wood when their screws are tightened.

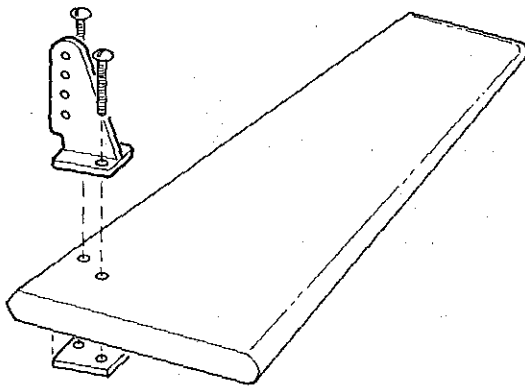

- 222. After the CA cures, (about one minute), run the $3/32$ " (2.3mm) drill bit through the drilled holes again to clear any rough spots out of them. Remove any rough spots on the control surfaces by lightly sanding the areas where the CA was applied with a sanding block.
- 223. Attach a control horn to the Elevator and to the Rudder with two 2-56 x $3/4$ " (2-56 x 19mm) machine screws and one control horn mounting plate, as shown. Turn the screws down until the control horns and mounting plates made firm contact with the balsa. Then, turn each screw in $1/2$ turn further. By tightening the screws in this manner, the control horns will not crush the balsa.
- 224. Temporarily attach the Rudder and Elevator to the fin and Stabilizer with the hinges. Do not glue the hinges in place at this time.

Rudder and Elevator Pushrods

The following instructions will show you how to make, install and adjust the pushrods. The only differences between the Elevator and Rudder pushrods are in their lengths; and that the Rudder pushrod exits the Fuselage through the top, while the Elevator pushrod exits through the right side. You will build both of these pushrods at the same time.

The pushrods transmit the servo's motion to the control surfaces. The parts that make up the pushrods will be subjected to heavy loads and vibration when the model is in flight. For this reason, the pushrods must be built and installed properly. Follow the instructions carefully.

You will need the parts illustrated below to complete this sub-assembly. The pushrods are in Bag Number Three (3). The remaining hardware parts are in the Fuselage Hardware Bag.

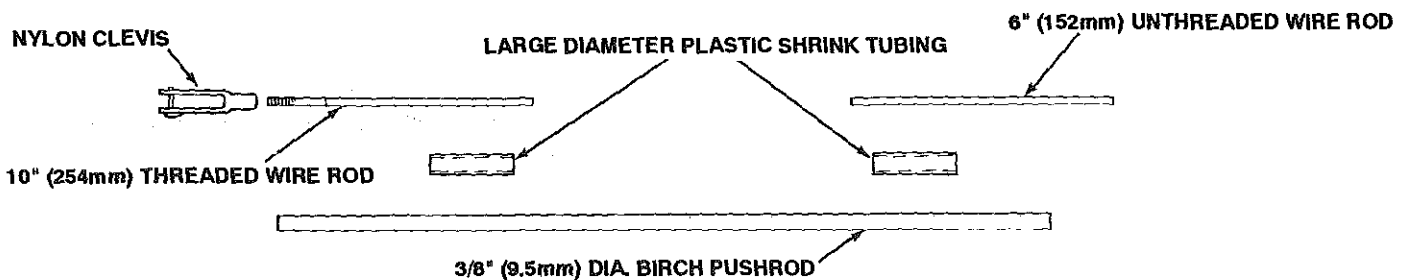

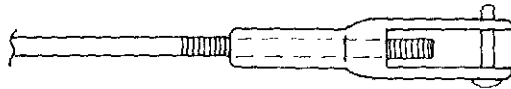

225. Screw a nylon clevis onto the end of two 10" (254mm) threaded wire rods. The clevises will be a tight fit on the rods and it will be necessary to hold the rods with a pair of pliers while turning the clevises.

Note: Be sure to turn the clevises all the way onto the center of the threaded portions of the two rods, as shown in the illustration.

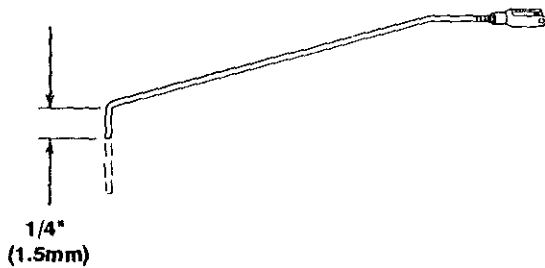

226. Position the clevis on one rod over the drawing of the clevis on the plan that connects to the Rudder control horn. (Fuselage Top View) Using the plan as a pattern, make the bend in the wire rod with a pair of pliers. Then, lay this rod over the drawing of the Rudder pushrod on the Fuselage Side View. Align the clevis over the drawing of the clevis on the plan. Hold the wire rod so that the bend in the wire faces up and, using a pair of pliers, make a 90° bend in the wire at the location shown on the plan. Cut the excess wire off 1/4" (6.4mm) from the 90° bend.

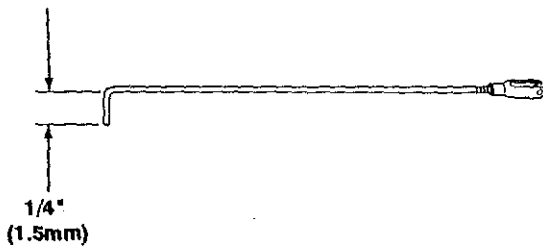

227. Using a pair of pliers, make a 90° bend 1/4" (6.4mm) from the unthreaded end of the other threaded rod, as shown. This rod will be used for the Elevator pushrod.

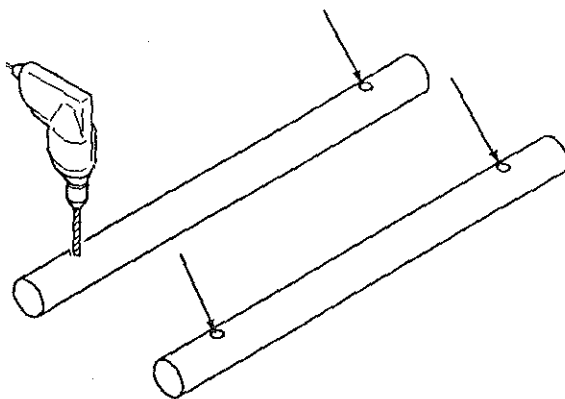

228. Drill a 3/32" (2.3mm) hole at each end of both 3/8" (9.5mm) dia. birch pushrods, at the locations shown on the plan (Fuselage Side View).

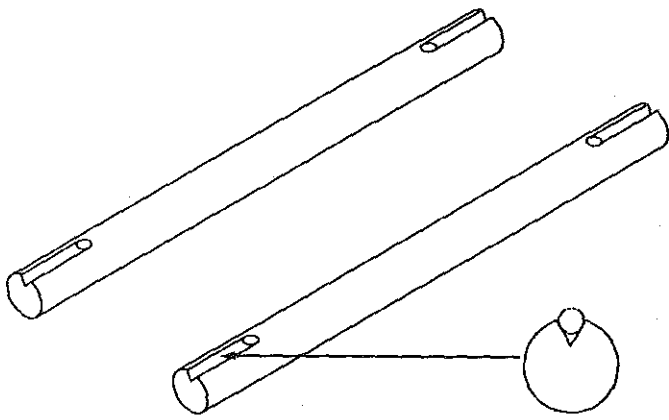

- 229. Using an X-Acto[®] knife, carefully cut a shallow V groove between the holes and the ends of the pushrods. Be sure the grooves are on the same side of each rod, as shown.

Note: Be careful not to split the pushrods when cutting the grooves. The grooves do not have to be deep.

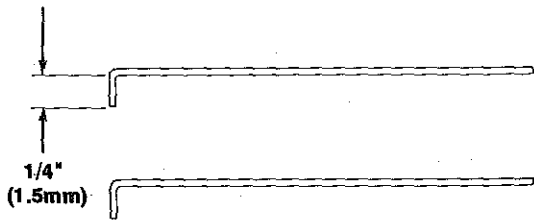

- 230. Using a pair of pliers, make a 90° bend 1/4" (6.4mm) from one end of two 6" (152mm) unthreaded wire rods.

Note: These rods will attach the pushrods to the servo output arms. Do not cut them to length at this time.

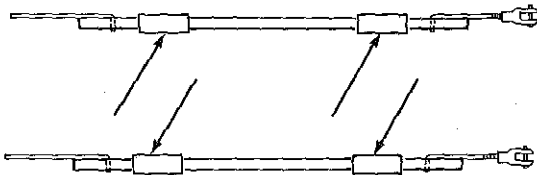

- 231. Cut the large diameter plastic shrink tubing into four pieces 3" (76mm) long. Slip two pieces of shrink tubing over each pushrod. Then, insert one threaded and one unthreaded wire rod (the ones you just made) into the holes at each end of each rod so they rest in the grooves, as shown. Be sure that the wire rods are inserted on the same side of each pushrod, as shown.

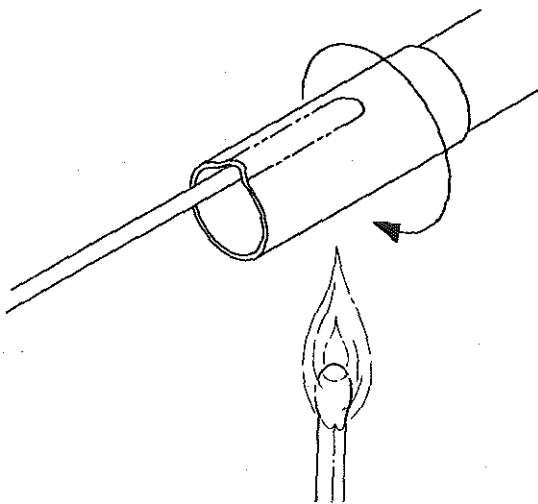

- 232. Slide one piece of shrink tubing over each wire rod. Then, rotate the shrink tubing about 2" (51mm) above a match flame to shrink the tubing around the pushrod and wire on both rods.

Note: The shrink tubing will contract when heated. Keep the tubing in motion over the match flame to avoid burning a hole in it.

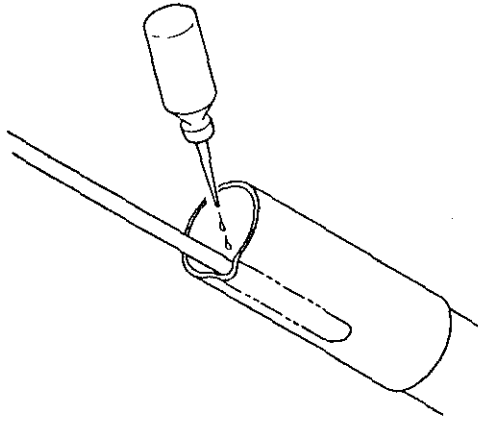

- 233. After shrinking the shrink tubing to a snug fit on both pushrods, run CA into the ends of both pushrods to bond the parts.

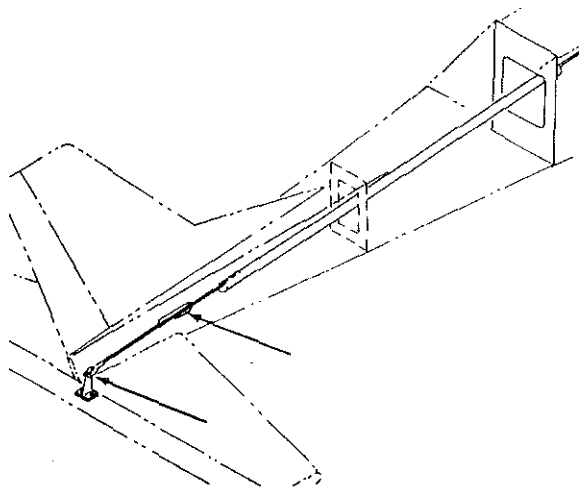

- 234. Unscrew and remove the nylon clevises from the two pushrods. Insert the threaded end of the Elevator pushrod through the hole in Part Three (3). Pass it down the inside of the Fuselage and out of the exit hole in the right side of the Fuselage at the Stabilizer. Then, screw the nylon clevis onto the end of the rod, in its previous position, and attach the clevis to the Elevator control horn, as shown here and on the plan.

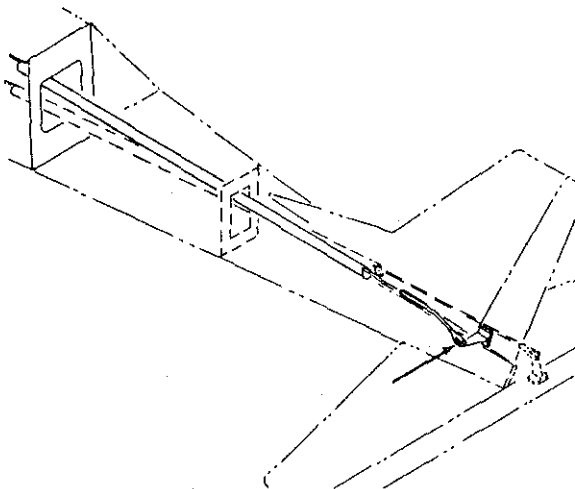

- 235. Insert the threaded end of the rudder pushrod through the hole in Part Three (3). Pass it down the inside of the Fuselage and out of the top of the Fuselage, next to the Fin. Screw the nylon clevis onto the end of the rod, in its previous position, and attach the clevis to the Rudder control horn.

Note: Be sure that the Rudder pushrod crosses over the Elevator pushrod, as shown on the plan.

- 236. Following the manufacturer's instructions, plug the servos into the receiver and connect the battery and switch harness.

Important

Before going further, read **Control Adjustments**, pages #86 - #88 and **Control Throws**, pages #89 & #90, under **Radio Equipment Installation**. This information will help you understand the terms and adjustments in the following instructions.

IMPORTANT

All of the illustrations in this manual show Mode 2 transmitters. If you have a Mode 1 or Mode 3 transmitter, refer to the radio manufacturer's instructions to locate the alignment of control functions for the control sticks and trim levers. Also, not all Mode 2 transmitters have the Throttle and Elevator trim functions located where shown in these instructions. Read the radio manufacturer's instructions carefully before going on.

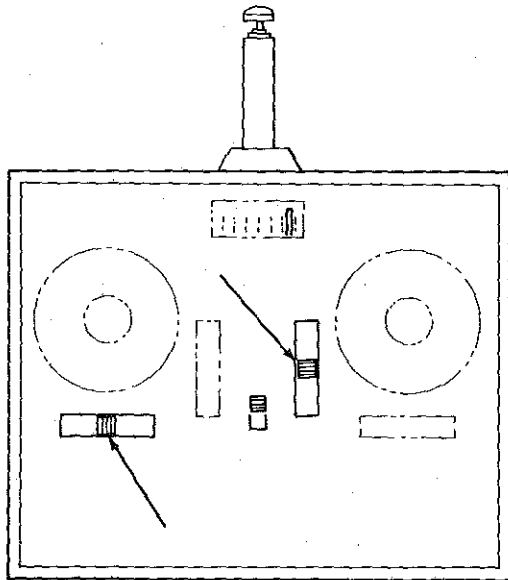

- 237. Turn on the transmitter and receiver and center the Rudder and Elevator trim levers, as shown.

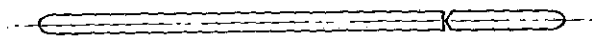

CORRECT

- 238. Center the Rudder and Elevator, as shown.

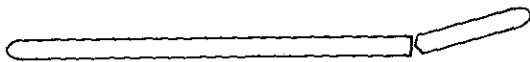

INCORRECT

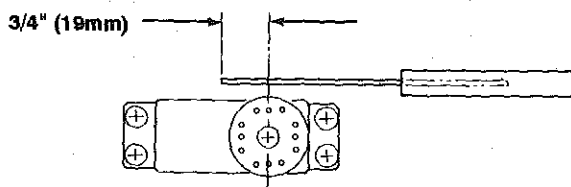

- 239. Cut the unthreaded ends of the pushrods 3/4" (19mm) ahead of the point where the Rudder and Elevator servo output arms pivot, as shown.

Note: Due to differing heights of servos, it may be easier to remove the pushrods in order to cut the wire ends.

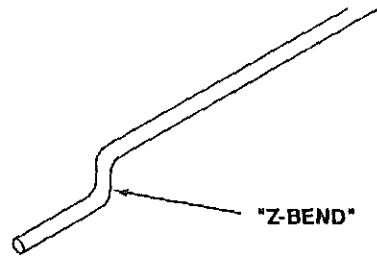
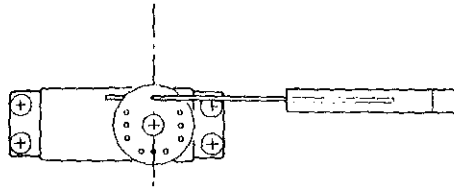

- 240. Using a pair of pliers, make two 90° bends in the pushrods to make a Z-shaped bend. (A "Z-Bend") Make the "Z-Bends" so that they are centered over the holes in the servo horns.
- 241. Insert the pushrods into the outside hole in the servo arm, as shown. Then, move the control sticks on the transmitter and check for free and smooth operation of the Rudder and Elevator.

Note: If there is any contact between the pushrods and Parts Three (3) and Four (4), it may be necessary to make a slight bend in the wire ends of either pushrod to obtain clearance. Also, check that the wire ends of the pushrods do not rub excessively on the pushrod exit holes in the Fuselage. If necessary, make mild bends in the wire ends to allow the pushrods to ride freely through the holes.

Throttle and Steering Pushrods

You will need the following parts to complete this sub-assembly - 2 - .047" x 19-7/8" (1.2mm x 505mm) wire pushrods, 1 - solder link, 2 - pushrod connectors and the small clevis. These items are packed in the Fuselage Hardware Bag. You will also need the previously fitted Nose Gear and Steering Arm.

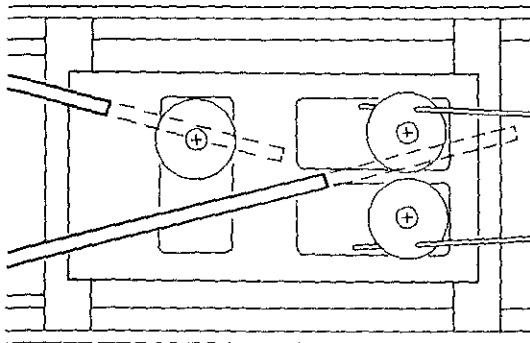

- 242. The nylon guide tubes that have already been installed in the Fuselage for the throttle and steering pushrods are oversized to allow for differences in servo positions. At this time, cut both nylon tubes with an X-Acto® knife so that they end about 1" (25.4mm) from their respective servos, as shown.

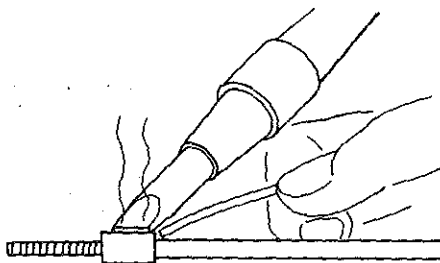

- 243. Bolt the engine to the motor mount. Also, install the nose gear and steering arm, securing the nose gear bearing block by tightening the screws on the steering arm.
- 244. Solder the metal solder link to the end of one 19-7/8" (505mm) wire rod, as shown. Once the solder link has cooled, screw the small clevis on the end.

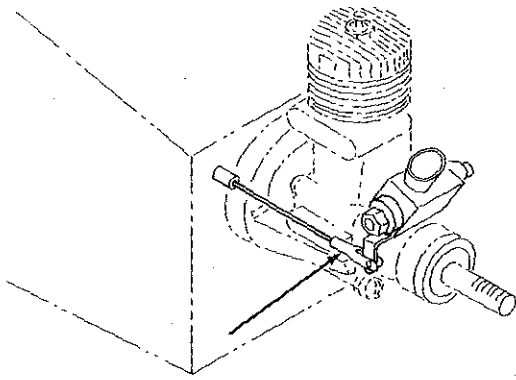

- 245. Slip the wire rod through the nylon tube in the firewall and connect the clevis to the carburetor output arm on the engine.

Note: It may be necessary to make a mild bend in the wire rod so that the clevis lines up with the carburetor output arm on the engine.

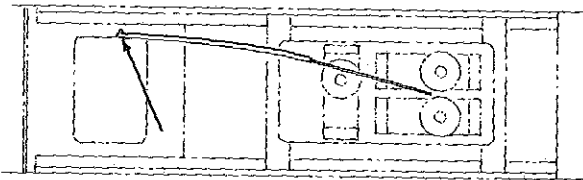

- 246. Push the nylon throttle tube against the side of Part Two (2), as shown on the top and side view of the Fuselage plan. Cut a notch in Part Two (2) at this point and glue the nylon tube into the notch with CA.

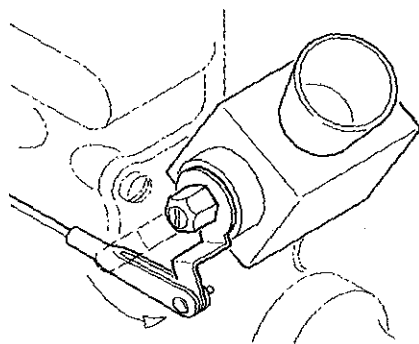
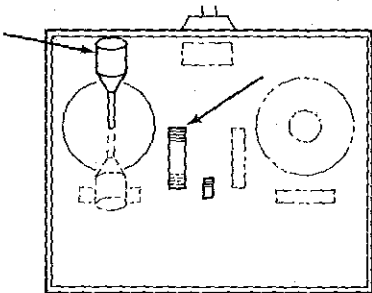

- 247. With the radio turned on, move the throttle control stick to the high throttle position. Also, move the throttle trim lever to the high idle position, as shown. Rotate the output arm on the engine to fully open the carburetor, as shown. Then, cut the wire rod 1" (25.4mm) behind the pivot point of the throttle output arm.

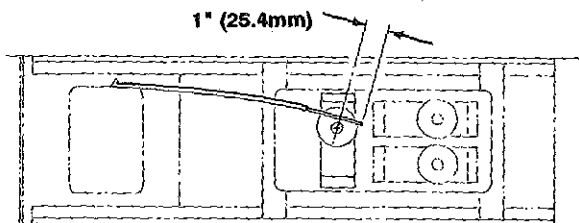

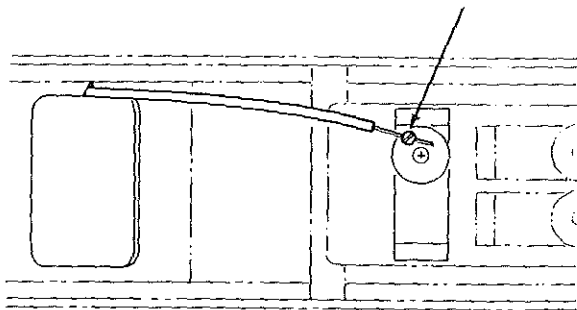

- 248. Install a pushrod connector to the outermost hole in the throttle output arm so that it is positioned as shown, ahead of the pivot point. Insert the pushrod into the pushrod connector and tighten the set screw.
- 249. Slowly close the throttle all the way. Then, slowly close the throttle trim lever all the way. Adjust the linkage so that the servo stops rotating in either direction, just before the carburetor output arm stops rotating.

Note: This adjustment may involve re-positioning the pushrod connector, or the clevis, to a hole closer to the pivot point of the servo or carburetor. At no time should the linkage allow the carburetor output arm to stall, or stop, the servo, as this can damage the servo. (If the servo is stalled it will, in most cases, emit a buzzing sound.)

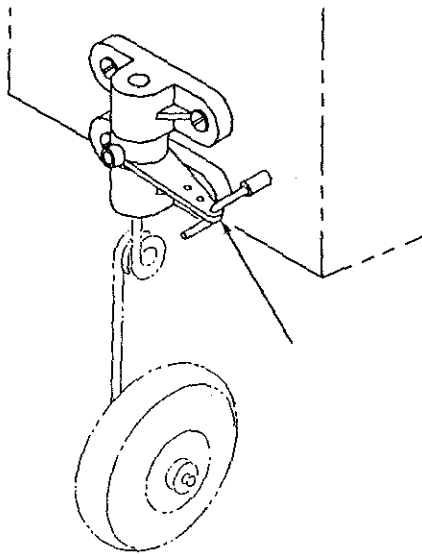

- 250. Make a "Z-Bend" 1/4" (6.4mm) from the end of the remaining 19-7/8" (1.2mm x 505mm) wire rod. Slip the rod through the nylon tube in the firewall and insert the bent end into the outermost hole in the steering arm.

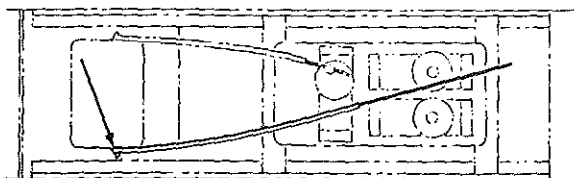

- 251. Push the nylon steering tube against the side of Part Two (2), as shown on the top and side views of the Fuselage plan. Cut a notch in Part Two (2) at this point and glue the nylon tube into the notch with CA.

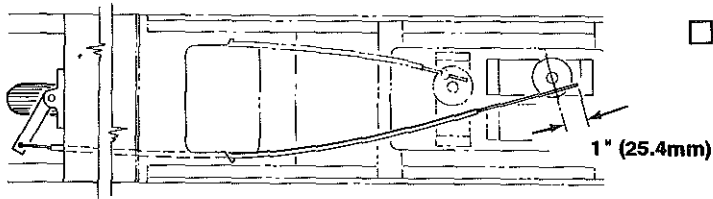

252. Loosen the set screw on the steering arm and position the nose gear so that the wheel is straight. Then, position the steering arm at the angle shown on the plan (Fuselage Top View) and tighten the set screw. Cut the other end of the wire rod 1" (25.4mm) behind the pivot point of the rudder servo, as shown.

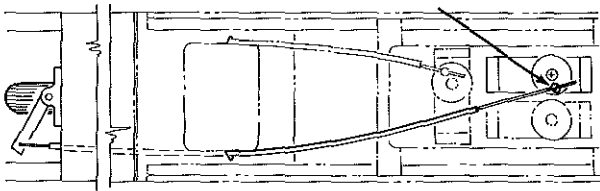

253. Install a pushrod connector on the rudder servo output arm, as shown on the plan. Insert the steering wire pushrod into the connector. Adjust it so that when the Rudder is centered, the nose wheel is also centered. Then, tighten the set screw on the pushrod connector.

Note: It may be necessary to make a gentle bend in the steering wire, while it is inserted in the nylon tube, in order for it to line up with the pushrod connector.

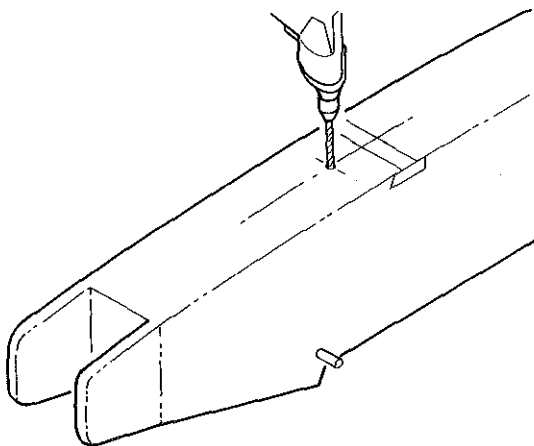

254. Drill a 1/4" (6.4mm) hole through the bottom center of the fuselage, at the location shown on the plan (Fuselage Side View). This hole will be used later as the receiver antenna exit.

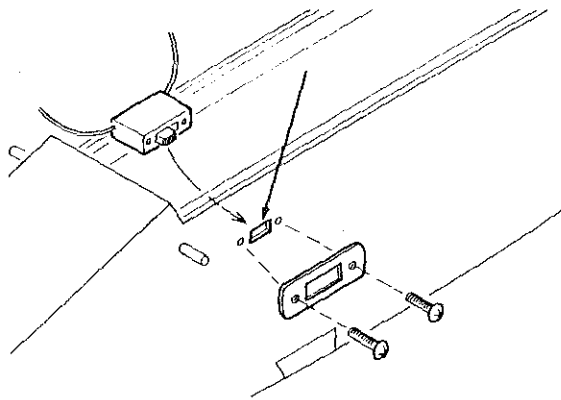

- 255. Cut a square hole and drill two 3/32" (2.3mm) holes for the receiver switch through the left Fuselage side, at the location shown on the plan (Fuselage Side View). Using the screws in the switch, attach it to the Fuselage.

Note: Most receiver switches have a metal cover plate that can be used as a template to cut and drill these holes.

Important

Be sure that the switch handle does not rub on the sides of the square hole and that the switch handle is free to travel to the full on and full off positions. If necessary, trim the hole to obtain this clearance. This is very important. If the switch is prevented from reaching its detent in the full on position, vibration from the engine could shut it off while the model is in flight, resulting in loss of control.

Aileron Pushrods

You will need the parts illustrated below to complete this sub-assembly. They are located in the Wing Hardware Bag.

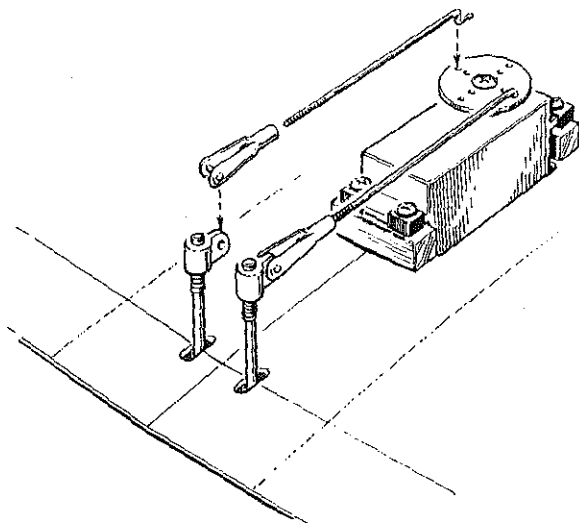
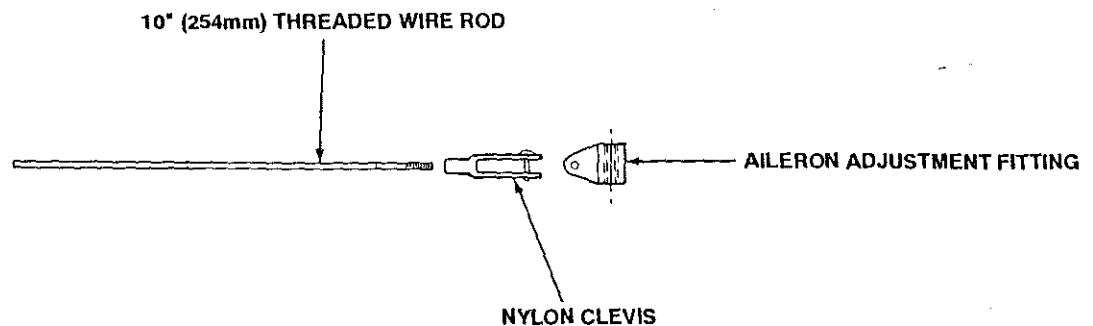

- 256. Plug the aileron servo into the receiver and center the aileron trim lever.

Note: It would be best to disconnect the rudder, throttle and elevator servos from the receiver. Then, connect the receiver, switch harness and battery pack to the aileron servo, on the workbench, when operating the aileron servo. That way, the Fuselage will be out of the way during construction of the aileron pushrods.

- 257. Screw the two aileron adjustment fittings onto the torque rods. Be sure they are at the same height on both rods. Screw two nylon clevises onto two 10" (254mm) threaded rods and attach to the aileron adjustment fittings. Center the ailerons and make a "Z-Bend" in each pushrod so that the bends are centered over the holes in the output arm. Connect the aileron pushrods to the aileron servo output arm.

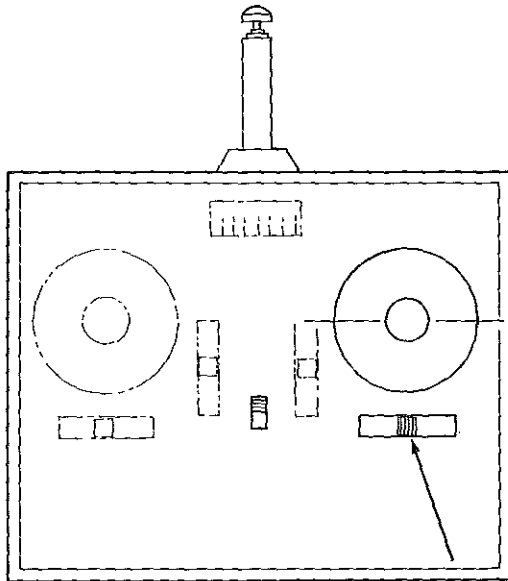

- 258. With the radio on, center the aileron trim lever. Position the torque rods at 90° to the bottom side of the Wing, as shown on the fuselage Side View on the plan. Then, by twisting the clevises in or out, adjust the length of the aileron pushrods so that they center the ailerons.
- 259. Move the aileron control stick and check for free operation of the aileron linkage.
- 260. All of the pushrods and control linkages have now been installed. At this time, remove the receiver, servos, servo tray, battery, switch harness, pushrods, tailhorns, engine, motor mount and the nose gear bearing blocks in the preparation for finishing your Aero-Star.

Finishing Your Model

There are many materials available for covering the framework of R/C models. They range from those that must be bonded to the structure with adhesives, to material that is simply ironed on. Some need to be painted and others have the finish built right in. There are also many different kinds of paints available for R/C models. Some are fuel-proof; that is, model fuel will not attack them, and others need to have a clear fuel-proof finish applied to protect them. The finishing of your Aero-Star is a matter of personal preference. If you are unfamiliar with these products, your hobby dealer can explain them and their application.

In the process of learning to fly, it's likely that your Aero-Star will receive some damage. Hopefully, this will be minor. However, any damage to the model, or its finish, will have to be repaired before the model can be flown again. Quite often, repairs to the model's structure go quickly. However, depending on the type of covering and finish you have chosen, repairs to these items, could take a great deal of time and effort. This is a very real concern that you should keep in mind when deciding on what kind of finish to apply to your Aero-Star.

Earlier in this manual, we recommended finishing your Aero-Star with Super Monokote. Super Monokote is a plastic pre-finished covering that is available in a variety of colors. It is bonded to the model with a hot iron and heat is used to shrink the material to a smooth, high-gloss finish. It can be repaired very quickly by simply ironing a patch of the same material over any damaged areas. Repairs to Super Monokote are easy, neat and almost invisible.

The model on the box top was finished with dark red and white Super Monokote. The chrome strips were cut from Super Monokote using a sharp knife and a straight edge.

If you should decide to cover your Aero-Star with one of the iron-on coverings, such as Super Monokote, the following hints may be of some help.

To avoid wasting material, cover large parts first and small parts last.

If you cover the model from the bottom up and from the back to the front, the seams will generally be less visible. For example, cover the bottom of the Stabilizer first; then the top.

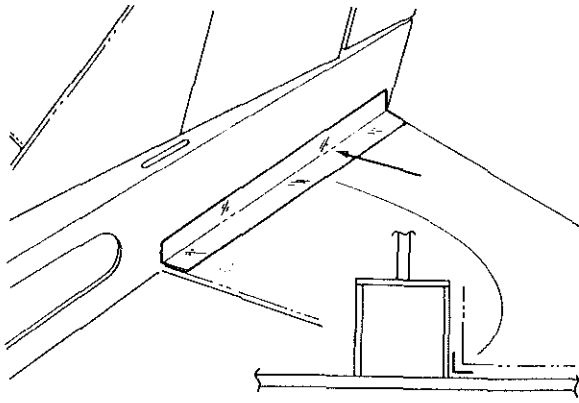

Some iron-on coverings will pull away from inside corners. To avoid having this happen, iron a strip of the material into the corner, as shown. Then butt the adjoining pieces into the corner. Avoid applying heat to both of the adjoining pieces at the same time.

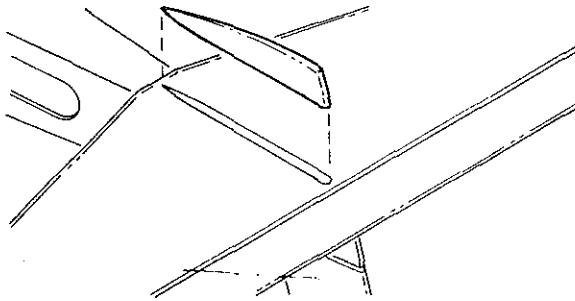

Cover the Tailskid before gluing it to the bottom of the Stabilizer. After the Stabilizer is covered, cut the material away from the area where the Tailskid will be glued. This will allow a strong wood to wood joint. And, by covering the Tailskid as a separate piece, you have avoided the work of covering an inside corner.

When cutting material that is already bonded to the model, be very careful not to cut into the wood. Doing so could weaken a part and cause it to break while the model is in flight.

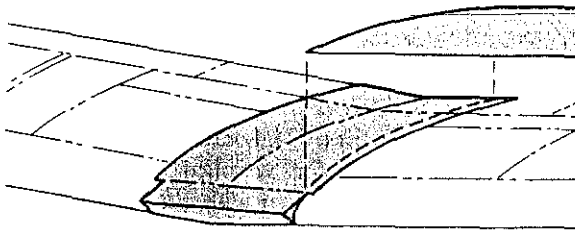

When covering the top center of the Wing, iron a strip of material across the center section and fairing, as shown. Then, overlap the following pieces, as shown. This will allow you to easily cover the Wing Fairing with the fewest number of pieces.

Decals

The decals supplied with the kit are made of self-adhesive mylar. They are to be positioned as shown on the plans. Prior to applying them, it would be a good idea to clean the finish with rubbing alcohol to remove any oil and dirt that might prevent the adhesive on the decals from bonding.

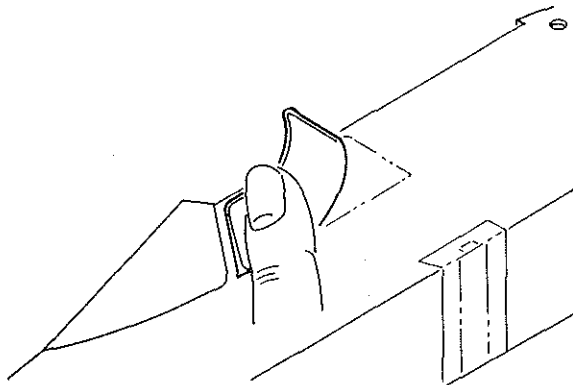

Apply each decal by first peeling it from the backing paper and then positioning one edge exactly as you want it, while holding the opposite edge up. Then, using your fingers, rub it down to the surface, working towards the end that is held up. This method of application will prevent air from being trapped under the decal.

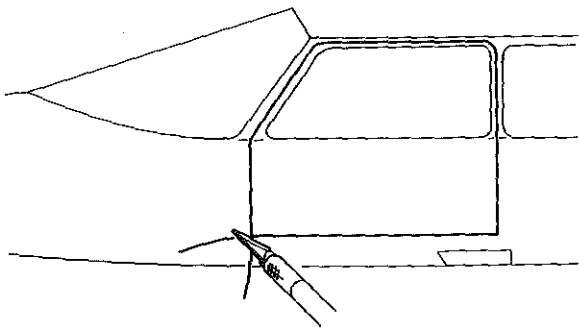

The long thin black strips on the decal sheet are to be used to make the door outlines. Align the end of a strip with the edges of the door outline on the side window and rub it down, as shown. After applying both of the vertical lines, apply a strip for the bottom of the door. Then, lay an X-Acto[®] knife against the corners, as shown, and pull the excess strips up to cut them off.

The decals are fuel-resistant, but not fuel-proof. This means that after being in contact with model fuel for a period of time their edges will lift and separate from the model. To prevent this from happening, we recommend that you apply a thin film of Pactra brand Formula-U clear urethane to the edges of the decals with a small paint brush. Formula-U clear urethane can be purchased from most hobby shops. If this product is unavailable in your area, a good alternative would be to apply a heavy coat of automotive wax over the decals. However, model fuel will eventually eat the wax away and it will have to be re-applied periodically.

Wing Dowels

You will need the following parts to complete this sub-assembly 2 - 3/8" x 5-11/16" (9.5mm x 144mm) dowels from Bag Number Three (3) and 1 - 12" (305mm) shrink tubing from the Fuselage Hardware Bag.

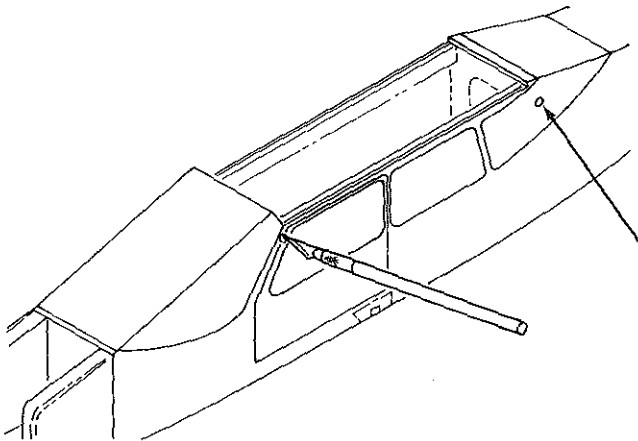

- 261. After all of the decals are applied, carefully cut open the round dowel holes with an X-Acto[®] knife. The holes can be located by rubbing a finger over the windows. Your finger will leave an indent over the holes.

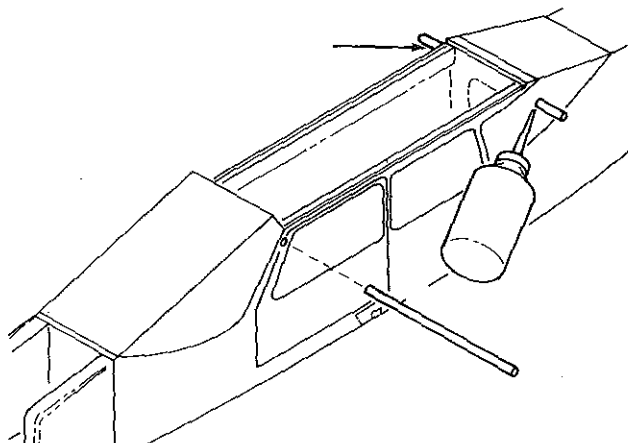

- 262. Insert the dowels into the dowel holes, as shown. Position them so that an equal amount of each dowel protrudes from each side of the Fuselage. Then, carefully apply CA to the dowels to bond them to the Fuselage.

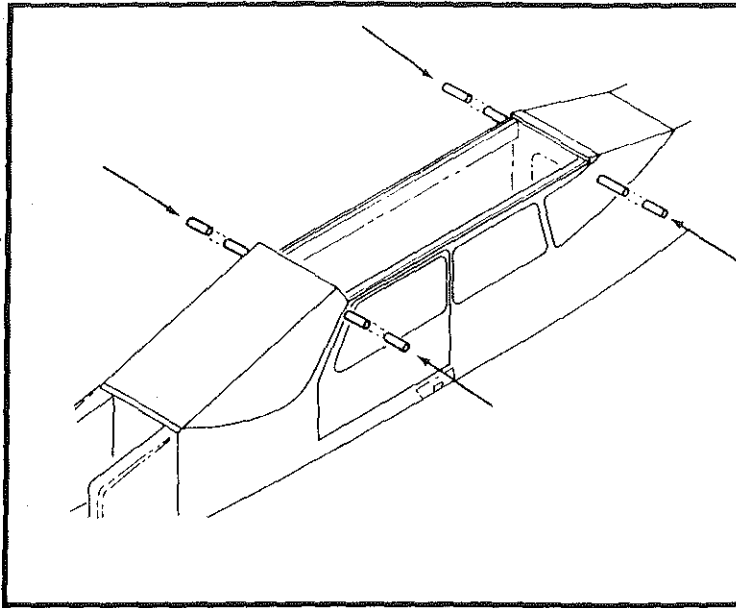

□ 263. Cut the shrink tubing into four pieces that are about 1/8" (3.2mm) longer than the dowels. Slip one piece of the tubing over each dowel. Then, heat the tubing with a warm iron to shrink the tubing around the dowels.

Note: As an alternative, a hair dryer or monokote heat gun can be used to shrink the tubing. However, a piece of heavy paper should first be slipped over the dowels, against the fuselage, to prevent the heat from wrinkling the decals. Do not use a match, or open flame, to heat this tubing. An open flame could ignite the finish on the Fuselage.

After the tubing has been shrunk, apply a small amount of CA to the ends of the wood dowels. If you have some fuel-proof black paint available, you could paint the ends of the dowels. This would give the dowels a uniform and complete appearance.

Hinging The Control Surfaces

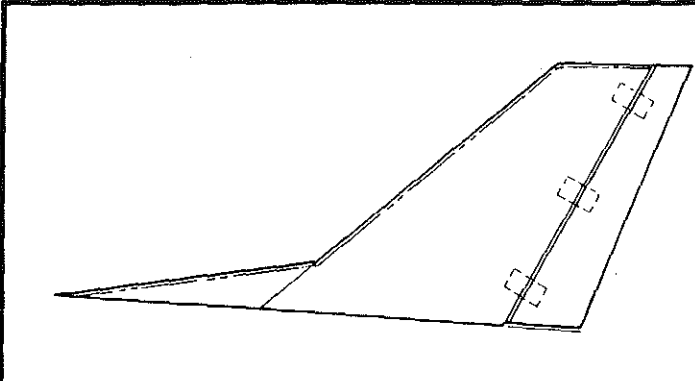

Note: Before permanently installing the hinges, all finish and trim colors should be applied.

Using the instructions on page #12 as a guide, install the Rudder on the Fin and glue it in place with CA.

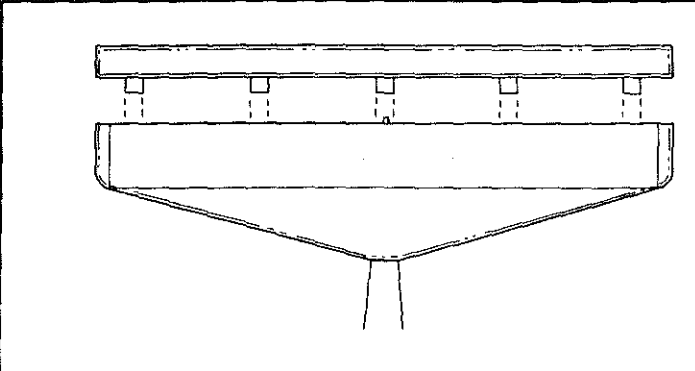

Attach the Elevator to the Stabilizer and glue in place with CA.

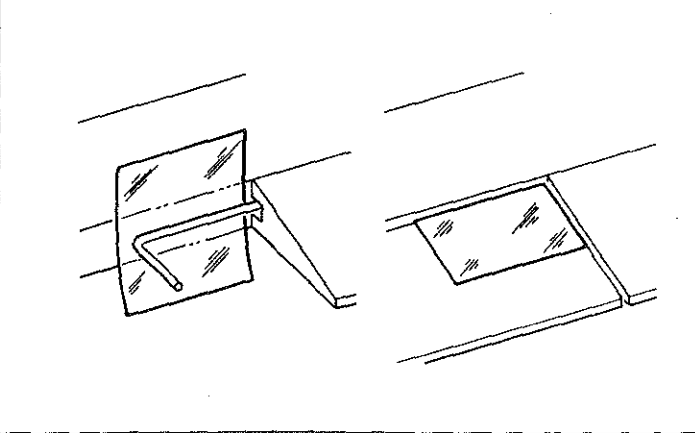

Monokote Finishing Note: Prior to joining the Ailerons to the Wing, cut a small square of Super monokote to fit across and over the torque rod. Slip it between the torque rod and Wing, as shown. After the Aileron is installed and secured with masking tape, iron the square to the Aileron, as shown. This will result in a neat installation and prevent any epoxy from leaking out of the slot in the Aileron as it cures.

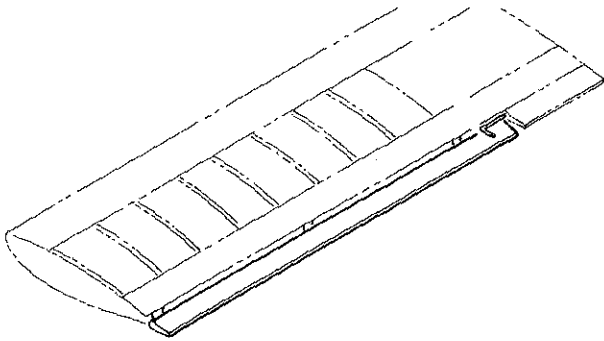

Mix up some epoxy and apply a small amount to the hole in the Aileron for the torque rod. Fit the Aileron on the wing and glue the hinges in place with CA.

Once all of the control surfaces are glued in place, you should move them back and forth several times to loosen them up. If the hinges are too stiff, you may not be able to get the control throws desired.

Radio and Equipment Installation

In this section, the radio components and all other equipment will be installed and adjusted in preparation for flying. Since you have already worked with most of these components during construction, their installation will be familiar to you. However, the following instructions will show you how to properly mount these components to protect them from the engine's vibrations.

Note: Unless the radio manufacturer has provided specific mounting hardware and instructions, all servos should be mounted as described in Instructions #264 & #265.

- 264. Position each servo on the servo tray and press down gently on the top of the servo case while tightening the four mounting screws. Be sure each servo is facing the right way. The screws should be turned down until they just make contact with the rubber grommets, no further. The rubber grommets act as shock absorbers and prevent vibration from damaging the electronics in the servos.

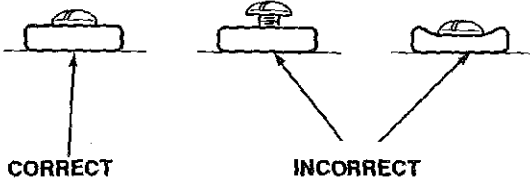

Note: The aileron servo should be installed in the Wing using this same technique for tightening the mounting screws.

- 265. Place the servo tray on the servo supports. Press down gently on the tray, near each grommet, while tightening the four mounting screws. Again, the screws should be turned down until they just make contact with the grommets.

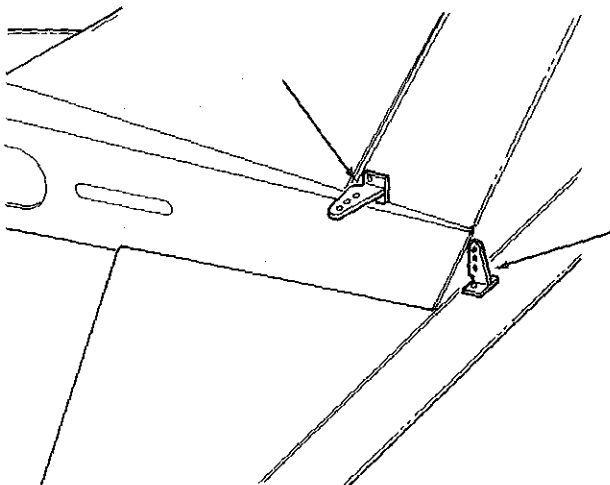

- 266. Attach a control horn to the Elevator and to the Rudder with two 2-56 x 3/4" (2-56 x 19mm) machine screws and one mounting plate, as shown. Turn the screws down until the control horns and mounting plates make firm contact with the control surfaces. Then, turn each screw in 1/2 turn further. By tightening the screws in this manner, the control surfaces will not be crushed.

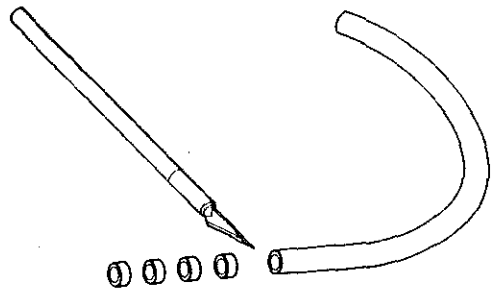

- 267. Cut four (4) 1/8" (3.2mm) pieces of silicon fuel line. Each of these pieces will be used to safety the nylon clevises that connect the pushrods to the control horns and aileron adjustment fittings. This is necessary to prevent vibration from opening the clevis.

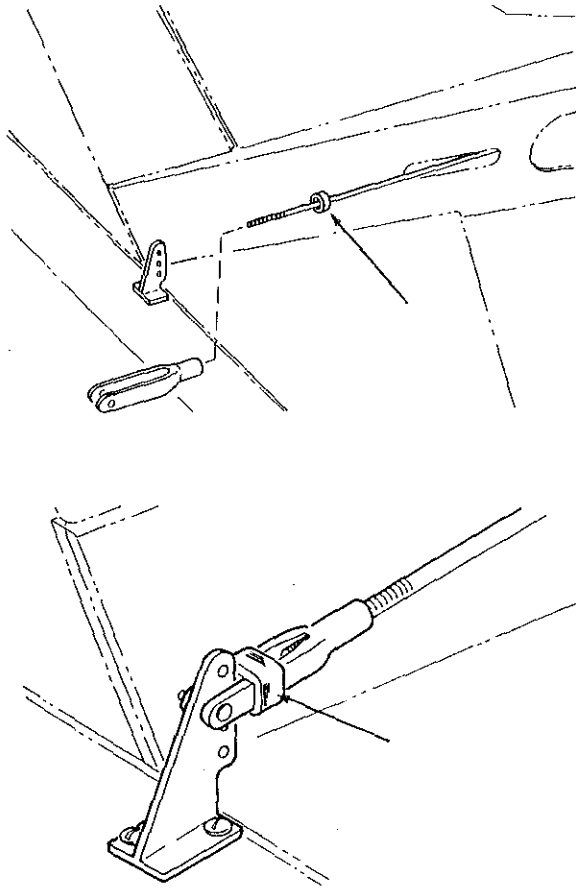

- 268. Slide the elevator pushrod into the Fuselage, exiting through the hole in the right side. Slip a piece of silicon fuel line over the wire rod and then screw the clevis onto the rod. Be sure the clevis is turned onto the center portion of the threads, as described in instruction #225. Connect the clevis to any convenient hole on the elevator control horn and then slide the fuel line over the clevis jaws, as shown.

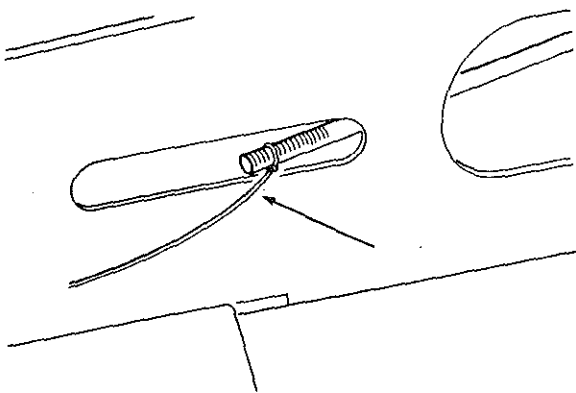

Note: If you have difficulty getting the threaded ends of the Rudder and Elevator pushrods to exit the holes in the back of the Fuselage, pass a loop of thin wire or string into the slot. Grab the end of the rod with the loop and pull it out of the slot while pushing on the other end of the pushrod. Also, due to slight differences in construction techniques, it may be easier to install the Rudder Pushrod before installing the Elevator pushrod. It doesn't matter which pushrod is installed first. What does matter is that the Rudder pushrod crosses over the Elevator pushrod, so that each of them has clearance from the other.

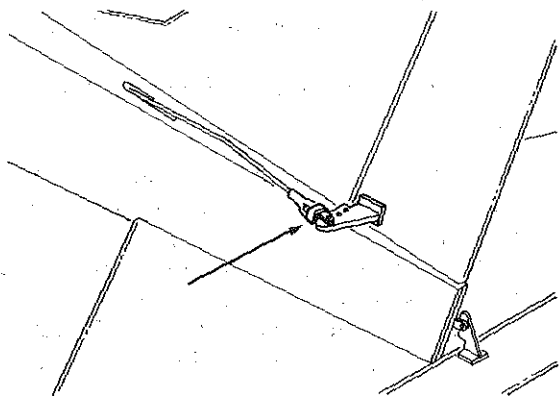

- 269. Slide the Rudder pushrod into the Fuselage, exiting through the hole in the top of the Fuselage. Slip a piece of silicon fuel line over the wire rod and then screw the clevis onto the rod. Be sure the clevis is turned onto the center portion of the threads, as described in instruction #225. Connect the clevis to any convenient hole on the Rudder control horn and then slide the fuel line over the clevis jaws, as shown.
- 270. Insert the unthreaded ends of the Elevator and Rudder pushrods into their respective servo control horns.

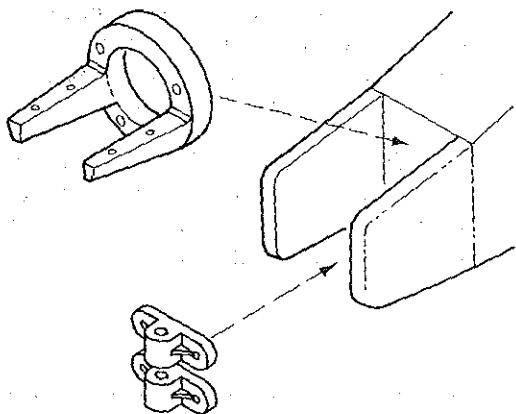

- 271. Attach the motor mount to the firewall with four 6-32 x 1" (6-32 x 25.4mm) machine screws. Make sure that the screws are tight. However, do not tighten the screws so much that the screw heads sink into the nylon mount.
- 272. Attach the nose gear bearing block to the firewall with four 6-32 x 1/2" (6-32 x 12.7mm) machine screws. Make sure that the screws are tight. However, do not tighten them so much that the nylon block becomes deformed.

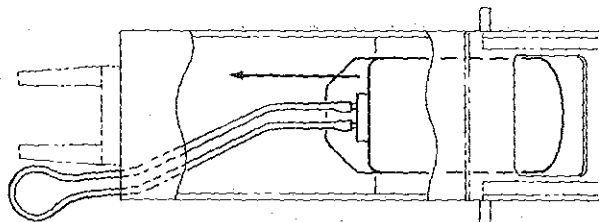

- 273. Following the manufacturer's direction, assemble the fuel tank. Note which tube is the fuel pick-up line and which tube is the vent line (See the Fuselage plan, Top View). The pick-up line, attached to the clunk, will be connected to the engine's carburetor after the tank is installed. Pass the ends of a 3 foot (914mm) piece of fuel tubing through the 1/4" (6.4mm) holes in the firewall. Connect the ends of the fuel tubing to the two tubes on the tank and pull the fuel tank into position in the Fuselage. Then, insert pieces of foam rubber around and under the tank to cushion it and prevent it from rubbing on the inside of the Fuselage. Leave the fuel line attached for now.

Note: After assembly and before installation, rotate the fuel tank in your hand and observe the clunk on the end of the pick-up line inside the tank. It should move around freely, without catching anywhere. You can check for leaks in the tank cap by blocking the ends of the two tubes with your fingers and holding the tank under water while squeezing it gently. If bubbles are observed, it is leaking. Re-seal the cap.

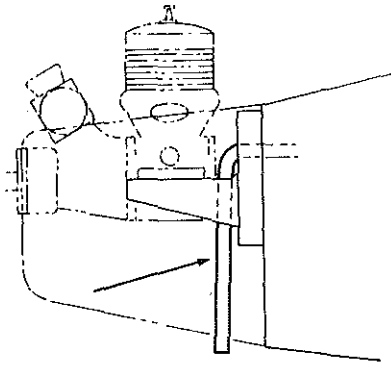

- 274. Attach the engine to the motor mount with four 6-32 x 3/4" (6-32 x 19mm) machine screws. Before tightening the screws, review instruction #168 to be sure the thrust line is correct. Be sure that these screws are securely tightened.
- 275. Attach the muffler to the engine, following the manufacturer's directions. Cut the loop of fuel line to a length that will allow the pick-up line to be connected to the carburetor. If your muffler has a pressure fitting, as shown on the plan, connect the vent line to this fitting. If not, the vent line should be passed down behind the engine and cut so that it will end below the bottom of the Fuselage, as shown.

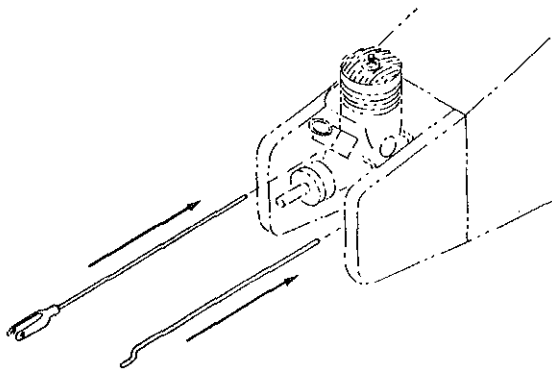

- 276. Slip the throttle pushrod into the nylon tubing in the Firewall and connect the clevis to the carburetor. Insert the other end into the pushrod connector on the throttle servo. Do not tighten the set screw on the connector at this time. It will be tightened later.
- 277. Insert the steering pushrod into the nylon tubing in the Firewall and into the pushrod connector on the Rudder servo. Do not tighten the set screw on the connector at this time. It will be tightened later.

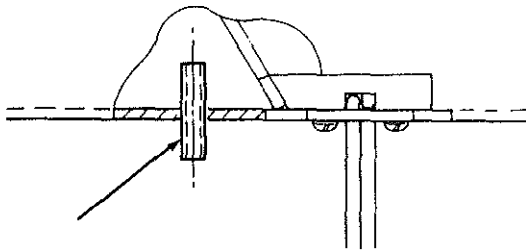

- 278. Cut a 1" (25.4mm) length of silicon fuel line and insert it half way into the 1/4" (6.4mm) hole in the bottom of the Fuselage. The fuel tubing will cushion the antenna wire and help to prevent it from rubbing on the bottom of the fuselage.

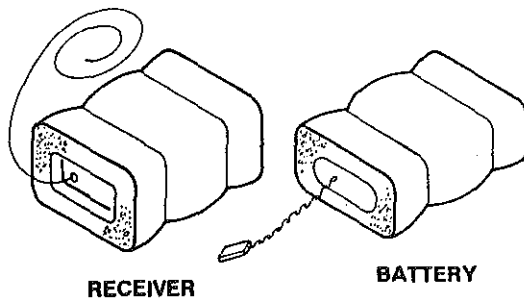

- 279. Wrap the receiver and battery pack in 1/2" (12.7mm) foam rubber, using small rubber bands to hold the foam in place. Slip the battery pack under the fuel tank, in the position shown on the plan (Fuselage Side View).

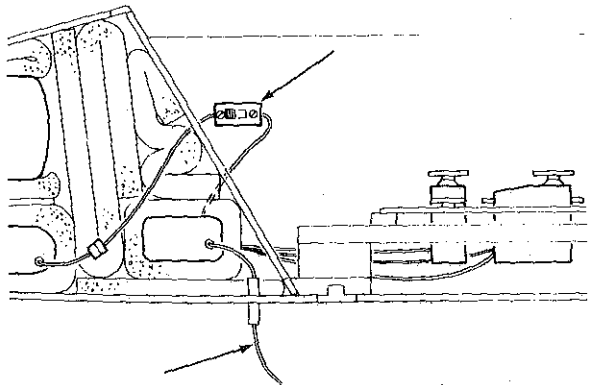

- 280. Attach the switch harness to the fuselage with the screws that come on the switch. Check the operation of the switch handle to be certain that it reaches the full on the full off positions, without interference from the wood around the square hole.
- 281. Following the manufacturer's directions, connect the plugs for the servos, battery and switch harness to the receiver. (Be sure the switch is off). Place a pad of foam rubber in the bottom of the Fuselage to cushion the wires and receiver. Place the receiver in the Fuselage, in the position shown on the plan. Pull the antenna wire through the fuel tubing in the bottom of the Fuselage. Then, fill the void ahead of part two (2) with foam rubber to hold the receiver, fuel tank and battery in position.

Note: When pulling the antenna wire out of the bottom of the Fuselage, be certain it is not wrapped around, or in contact with, any other wires as this could cause a loss of radio range, or control.

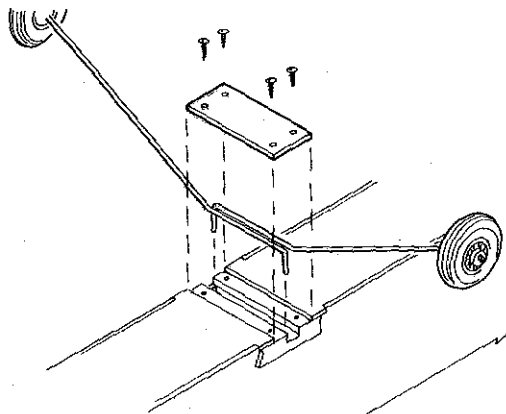

- 282. Insert the main landing gear legs into the main gear block. Position the cover plate on the gear block and secure it with four #2 x 1/2" (#2 x 12.7mm) sheet metal screws, as shown.

Note: There is a left and a right main landing gear. Be sure to install them so that both gear rake back towards the rear of the Fuselage, as shown on the plan.

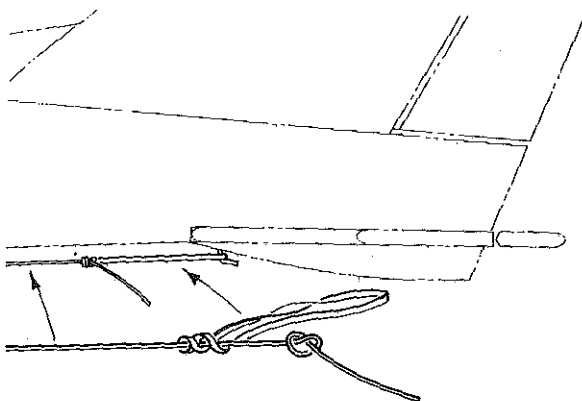

- 283. Press a t-pin into the bottom of the tail skid and cut it off, as shown on the plan. Tie a knot near the end of the receiver antenna and tie a rubber band to it, as shown. Slip the end of the rubber band over the pin.

Note: Tying a knot in the receiver antenna will not shorten it enough to affect the receiver's performance.

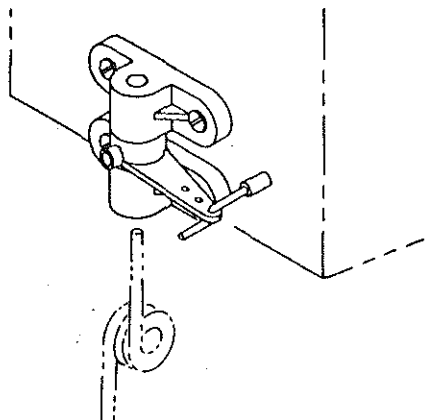

- 284. Slip the steering pushrod onto the steering arm and position the arm in the nose gear bearing block. Insert the nose gear into the bearing block and through the steering arm. Lightly tighten the set screw on the steering arm to hold the nose gear in place.

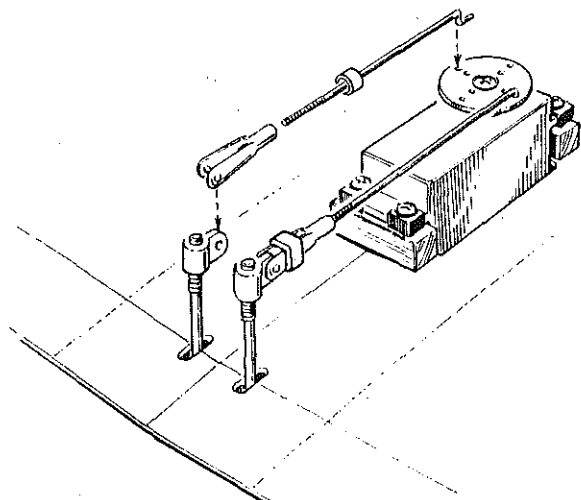

- 285. Screw the two aileron adjustment fittings onto the torque rods. Be sure that they are at the same height on both rods. Slip a piece of fuel line over each of the aileron pushrods and then slip the ends of the pushrods through the servo control horn. Attach the clevises to the aileron adjustment fittings and then slide the fuel tubing over the jaws of the clevises, as shown.
- 286. Following the manufacturer's directions, attach the propeller and spinner to the engine.

Control Adjustments

Important

The information in this, and the following sections, will determine how well your Aero-Star will fly. Read and follow the instructions carefully. If you do not understand an instruction, seek the help of an experienced flier.

In this section, the control directions will be checked and the control throws adjusted. The controls **must** move in the correct direction when the control sticks are moved. Otherwise, it will be impossible to control the model in flight. Also, the control throws, or the amount of movement of the controls, **must** be set properly or they will either have too much authority or too little. Neither situation is good.

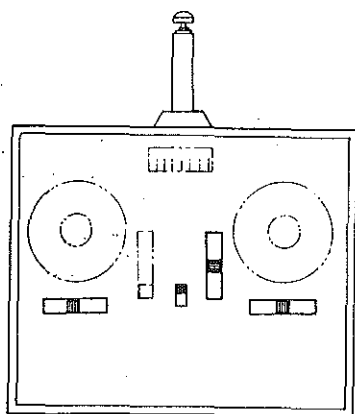

- 287. Position the Wing close enough to the Wing Saddle to allow you to plug the Aileron servo into the receiver. Then, turn on the transmitter and the receiver. Center the Aileron, Elevator and Rudder trim levers, as shown.

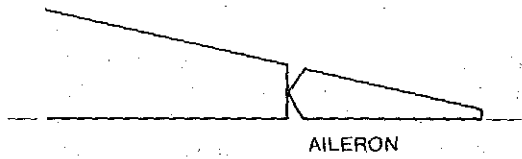

- 288. Working on one control surface at a time, center the rudder, elevator and both ailerons by turning the clevises in or out.

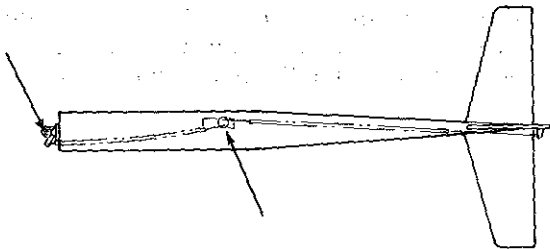

- 289. Loosen the set screw on the nose gear steering arm. Center the nosewheel and set the steering arm at the angle shown on the plans (Fuselage Top View). Then, tighten the set screw on the steering arm and the set screw in the pushrod connector for the steering pushrod.

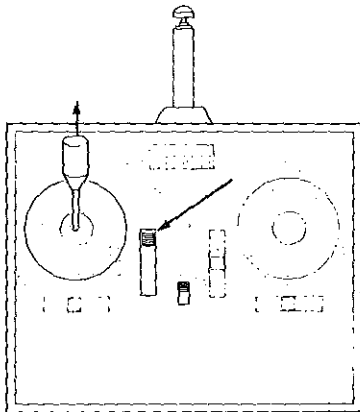

- 290. Set the throttle control stick and the throttle trim lever in the full open position, as shown. Position the carburetor output arm in the open position and tighten the set screw in the pushrod connector for the throttle pushrod. Adjust the throttle linkage as explained in Instruction #249.

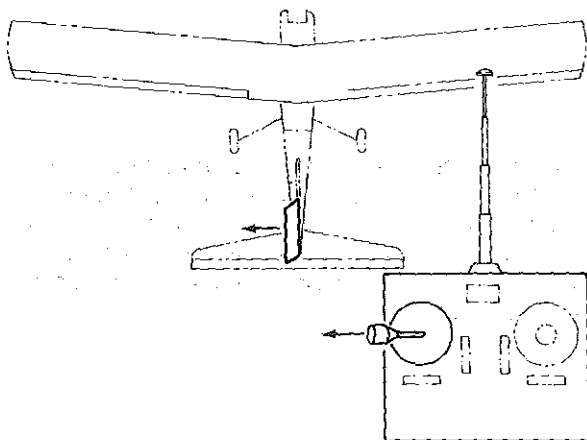

- 291. Place the Wing on the Wing Saddle and, holding the transmitter in your hands, stand **behind** the model.
- 292. As you move the Rudder control stick to the **left**, the Rudder should also move to the left, as shown. Moving the Rudder control stick to the right should make the Rudder move to the right.

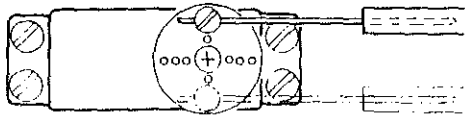

- 293. Note: If the Rudder, or **any** control surface, does not move in the directions described in these instructions, shift the pushrod connector to the opposite side of the servo output arm, as shown. This will reverse the direction of travel. On radios with servo reversing, this adjustment can be done with a switch on the transmitter.

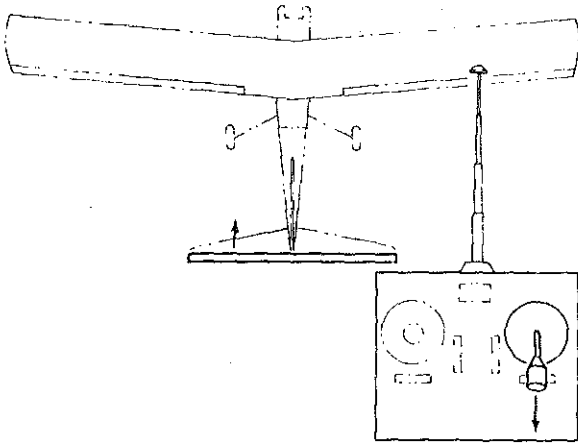

- 294. As you move the Elevator control stick **back**, the Elevator should move **up**. As you move the Elevator control stick forward, the Elevator should move **down**.

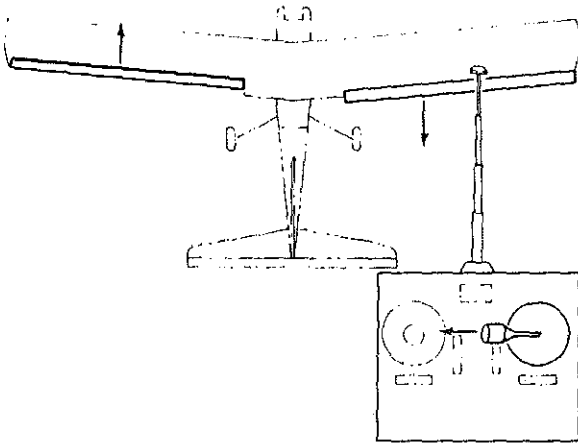

- 295. As you move the Aileron control stick to the **left**, the **left** aileron should move **up** and the **right** aileron should move **down**. As you move the Aileron control stick to the right, the right aileron should move **up** and the left aileron should move **down**.

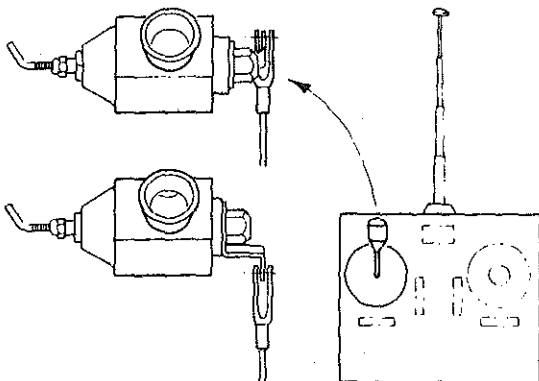

- 296. As the throttle control stick is moved **forward**, the throttle barrel in the carburetor should open. (With most engines, a forward movement of the throttle pushrod opens the carburetor barrel.) As you move the throttle control stick back, the throttle barrel should close.

Control Throws

The following control throws are recommended starting points. After learning to fly, you may want to increase, or decrease, these throws to suit your preference in the way your Aero-Star "handles."

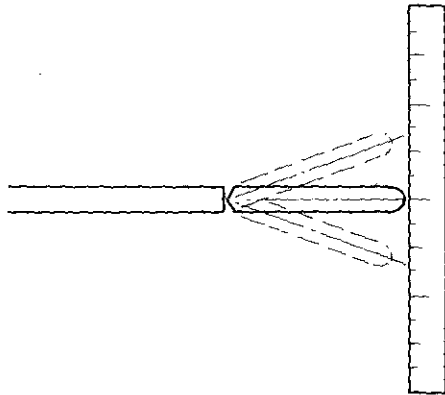

Measure the control throws with a ruler held near the trailing edge of each control surface, as shown.

Ailerons - 3/8" (9.5mm) up, 3/8" (9.5mm) down

Note: Measure each aileron separately. A difference in the control throws between the two ailerons can be adjusted by raising or lowering one aileron adjustment fitting. Both ailerons should have the same throws.

Elevator - 3/8" (9.5mm) up, 3/8" (9.5mm) down

Rudder - 1" (25.4mm) left, 1" (25.4mm) right

Note: Measure the Rudder throw at the bottom of the trailing edge.

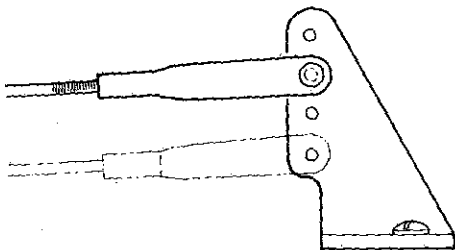

The **amount** of control throw is adjusted by moving the clevises on the control horns, or the pushrod connectors on the servo output arms, to holes closer or farther away from the points of rotation. For example, if you wanted to **decrease** the throw of the Elevator, you could move the clevis on the Elevator control horn to a hole **farther** away from the hinge line, as shown. If you wanted to **increase** the throw, you would move the clevis to a hole closer to the hinge line.

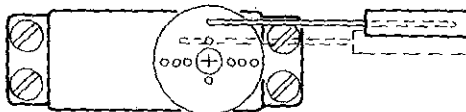

Quite often, it's not possible to obtain the desired amount of control throw by only adjusting the clevises on the control horns. In that case, you can move the pushrod on the servo output arm to a hole closer, or farther away from, the pivot point of the output arm, as shown.

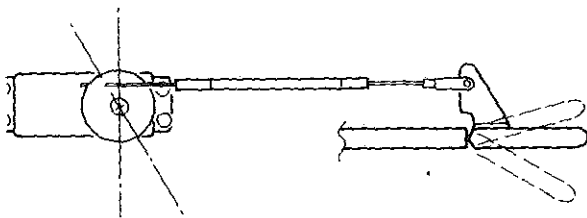

You may find that a control surface will move a greater distance on one side of the neutral position, as shown. This is called **differential**. It can be caused by a pushrod that is not aligned 90° to the pivot point of the servo, as shown.

Note: Most servos have a splined output shaft that allows the output arm to be adjusted so that differential control can be increased, decreased, or eliminated. See your radio operating manual for an explanation of this adjustment.

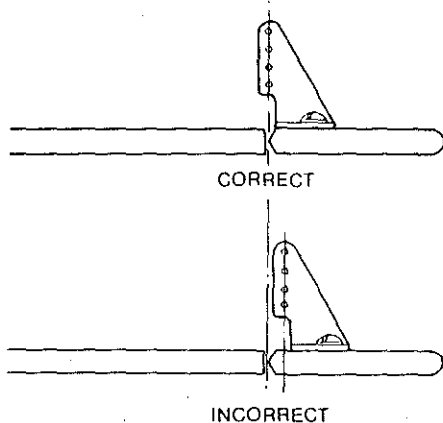

Differential can also be caused by a control horn that does not have its clevis holes aligned with the hinge line, as shown. This is the most common cause of differential and can be easily corrected by remounting the control horn in the proper position.

Don't be concerned if you should find a slight amount of differential present in the control surfaces of your Aero-Star. Up to 1/16" of differential will not even be noticeable in the way the Aero-Star handles in the air.

Balance

Important: The following instructions will show you how to properly balance your Aero-Star. Follow them carefully and do exactly as instructed.

In order for an airplane, even a model airplane, to fly properly, it **must** be balanced. Otherwise, the Elevator and Rudder will not be able to control the model and it will crash. The symbol  on the plan indicates the point at which the model must be balanced. The letters C.G. in the symbol mean **center of gravity**.

To balance your Aero-Star, **all** of the parts and components **must** be installed in their **correct** positions on the model. For example: the propeller, spinner and muffler must be attached to the engine; the fuel tank and fuel lines must be installed and connected; the battery pack and receiver must be in their proper locations in the Fuselage; all pushrods must be installed and connected, etc.

At this time, double-check to be certain that all parts and components are installed, that they are installed properly and in the right locations.

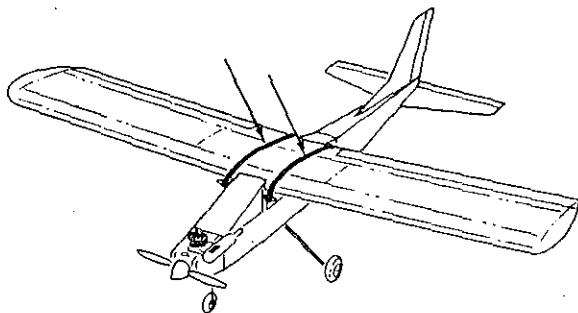

297. Attach the Wing to the Fuselage with twelve (12) No. 64 rubber bands, six per side, as shown.

Note: The model is to be balanced with the fuel tank **empty**.

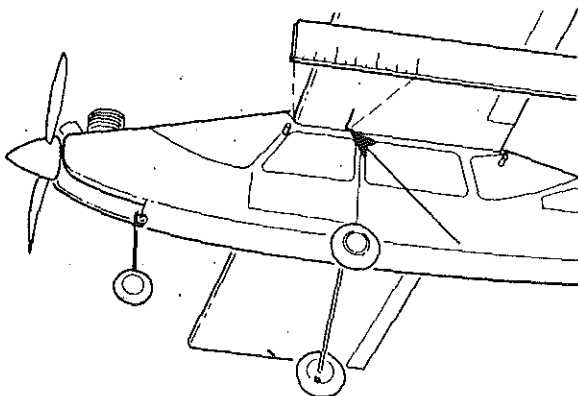

298. Using a ruler, measure back from the **leading edge** of the Wing 3-13/16" (97mm). Make a pencil mark at this point on the bottom of the Wing, next to the Fuselage, as shown. Then, make the same measurement and mark on the opposite Wing. These pencil marks are the locations of the center of gravity.

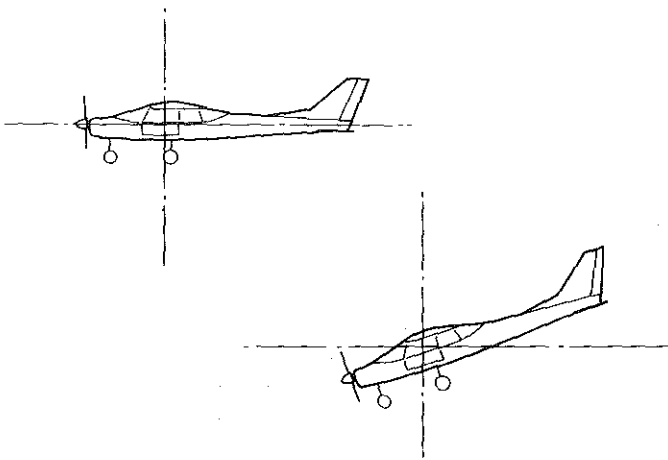

- 299. Place a fingertip on each pencil mark and lift the model. If it is in proper balance, it will sit on your fingertips in a level or slightly nose down attitude, as shown. If this is the case with your model, it is properly balanced and you can ignore the following instructions.

Note: Due to slight weight differences among different types of components, it's possible that your Aero-Star will not be in balance. If this is the case with your model, continue with these instructions.

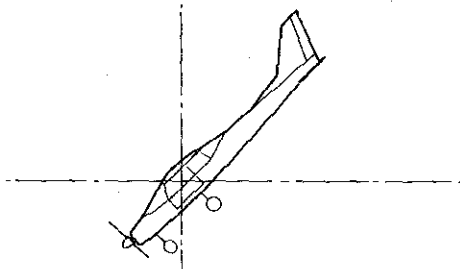

- 300. If your Aero-Star sits on your fingertips in an extreme nose down attitude, as shown, it is nose heavy and weight will have to be added to the tail. **Do not** attempt to fly your model if it is nose heavy. This is an unsafe and dangerous condition.

Note: If possible, move the battery pack further back in the Fuselage. This change may be enough to bring the model into balance. If not, you can purchase lead weights from your hobby dealer that have an adhesive backing. They should be placed on the bottom of the Stabilizer, next to the Tailskid. Add weight at this location until the model is balanced.

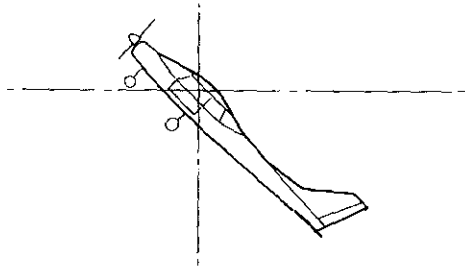

- 301. If your Aero-Star sits on your fingertips with the tail low, as shown, **do not** attempt to fly it. This is what is known as a tail heavy condition and is very dangerous and unsafe. Weight will have to be added to the nose of the model to bring it into balance.

Note: In the case of a tail heavy model, lead weights can be positioned inside the Fuselage in the space under the fuel tank, immediately behind the Firewall. When enough weight has been added to bring the model into balance, the weights should be permanently secured with epoxy.

At this point, your Aero-Star should be properly balanced. In the future, if you should change any major components such as the motor, muffler or battery pack; it will be necessary to re-balance the model. Keep this in mind.

Flying

At this point, your model is now ready to fly. This section will tell you some of the things you will need to know, and what equipment you will need, before going to the flying field. Read it carefully. It is just as important as building the model, and, in some cases, can make the difference between a successful first flight and a crash.

Theory of Flight

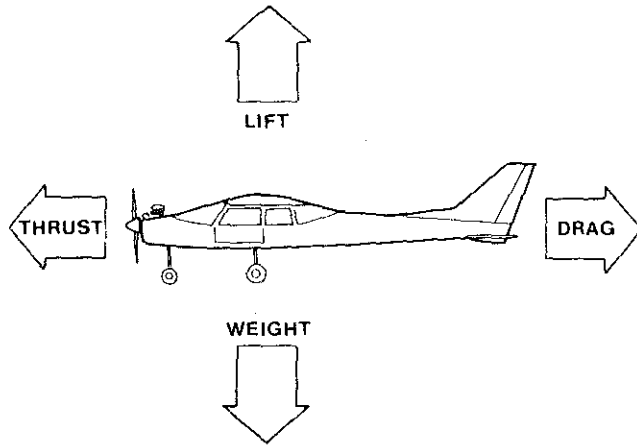

There are four forces that act on any model in flight. They are; lift, drag, thrust and weight. Lift is produced by the model's wing which causes the air flowing over the top of the wing to be at a lower pressure than the air flowing under it. This difference in pressure causes the wing to want to move upward. Weight, or gravity, causes the model to want to fall. When the lift produced by the wing is equal to the weight of the model, it will fly. If the lift is greater than the weight, the model will climb. If the lift is less than the weight, the model will descend.

Thrust is the force produced by the model's propeller. A propeller is nothing more than a wing that is turned through the air by the engine. The propeller produces thrust in the same way that the wing produces lift. As the engine speeds up, it turns the propeller faster and produces more thrust. Thrust works against drag, which tends to slow the model down.

Drag is caused by the friction of the air rubbing against the model as it moves through the air. As the model flies faster, drag increases and more power (thrust) is needed to increase the speed.

When lift equals weight and thrust equals drag, the model will fly at a constant altitude and speed.

The Controls

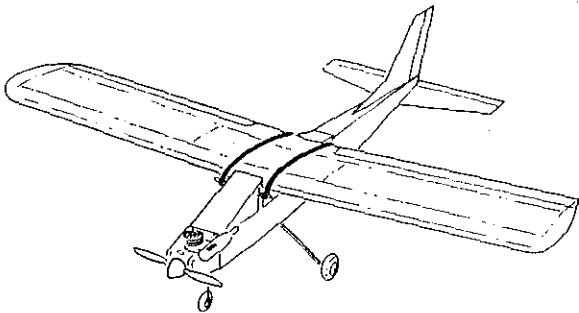

The Elevator, Throttle, Ailerons and Rudder are used to make the model climb, descend and turn. By moving the controls, air is deflected, causing the model to change its attitude and speed.

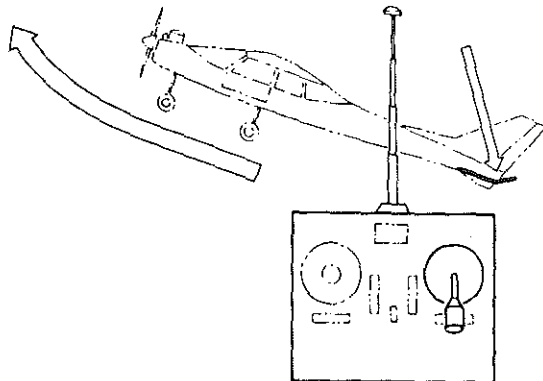

The Elevator makes the model **pitch**, or rotate. This movement controls the ability of the model to climb and dive. If the Elevator control stick is moved back, the Elevator moves up. This forces the Tail down, increasing the amount of lift that the Wing produces. Since the lift is now greater than the weight, the model will climb. However, as the model climbs, gravity (weight) will slow it down.

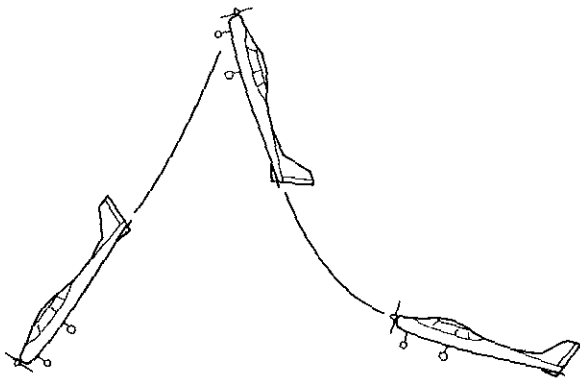

If the model slows too much, the speed of the air flowing over the Wing will not be fast enough to produce enough lift to support the weight of the model and it will fall. This is called a **stall**. To prevent a stall, the angle of the climb must be shallow enough to allow the model to maintain enough speed, called **airspeed**, to support its weight.

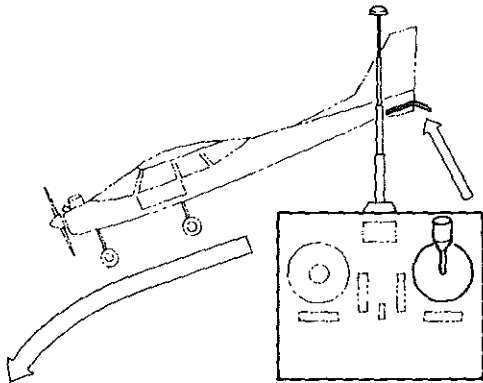

If the Elevator control stick is moved forward, the model will dive. Gravity (weight) will assist the Elevator by pulling the model down and the speed will increase; just like a car rolling downhill. If the speed becomes too great, it's possible that the force of the air rushing past the model could tear it apart. So, whenever the nose of the model is pointed down, the throttle, which controls the engine, should be reduced.

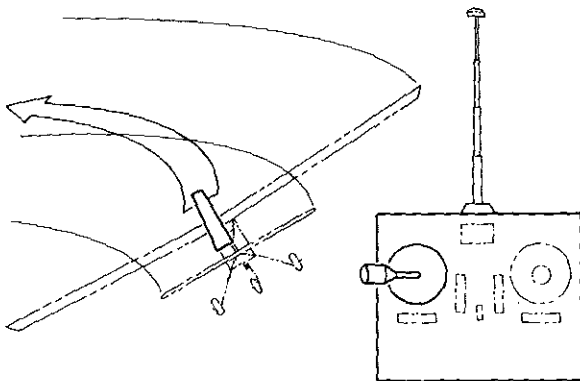

The Rudder controls the ability of the model to turn left and right. If the Rudder control stick is moved to the left, the Rudder moves to the left; causing the model to turn left. However, the Wing's dihedral will cause the model to roll in the direction of the turn. This is desirable because it prevents the model from skidding, or sliding sideways, in the turn.

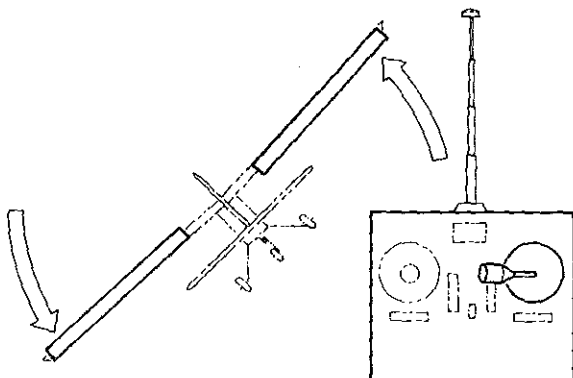

The ailerons control the model's ability to roll. If the aileron control stick is moved to the **left**, the left aileron will move **up** and the right aileron will move **down**. This will cause the model to roll to the left. However, the model will not change direction. It will **only** roll.

When the ailerons are used in combination with the Elevator, or Rudder, they make it possible to control the model in a quick and precise manner.

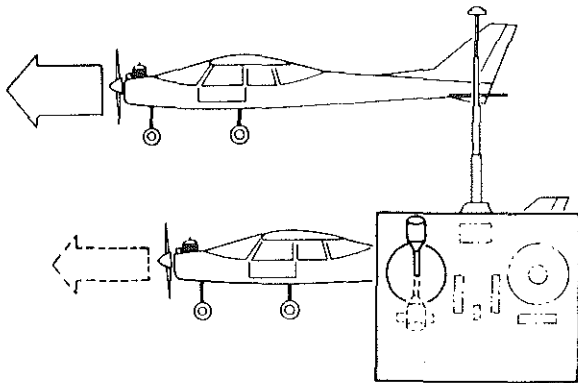

The Throttle controls the amount of thrust that the propeller produces. As the throttle control stick is moved forward (opened), the engine's speed, revolutions per minute (or RPM), increases and the propeller turns faster, producing more thrust. As the throttle control stick is moved back (closed), the engine's RPM is reduced, reducing the propeller's thrust.

If the engine stops while the model is flying, gravity (weight) will cause the model to descend. Gravity will provide the thrust lost by the propeller, just like a car rolling down a hill, and the model will **glide**.

Note: The above explanations are only basic information. A more thorough, yet easy to understand, discussion of these subjects and their relationship to flying is available in any **private pilot** training manual. These books are available at most public libraries, and we urge you to read one of them. Typically, the first part of these books deal with the theory of flight and the use, and effect, of the controls. This knowledge can be directly applied to the flying of R/C model aircraft.

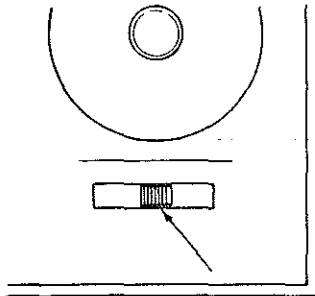

The small levers under, and next to, the control sticks are the trim levers. They are used to adjust the point at which the controls rest when the control sticks are centered. The trim levers are to be positioned so that the model will fly in a straight line at a constant altitude, when the control sticks are in their neutral, hands-off, positions. The **trimming** process must be done while the model is in flight. Initially, it should be done by someone with experience. However, the process is as follows:

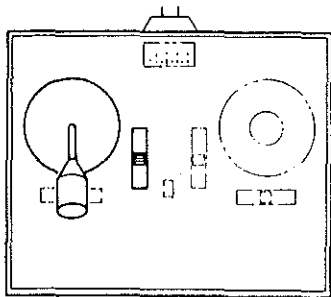

With the throttle stick all the way back, the throttle trim lever should be set so that when the lever is moved all the way back, it will shut the engine off. At any other position, it should adjust the idle speed of the engine.

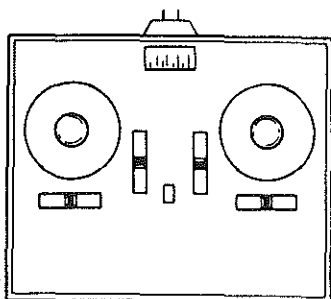

All of the remaining trim levers are adjusted with the control sticks at their neutral positions. Initially, we had set up the controls with the trim levers in their center positions. This was done so there would be some adjustment available in each direction.

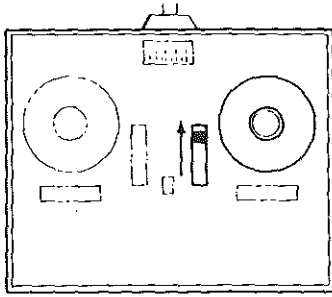

With the model in flight and the control sticks in their neutral (hands-off) positions, the trim levers are adjusted so that the model will not change altitude or attitude. For example, if you release the control sticks and the model climbs, you would move the Elevator trim lever forward. This would move the Elevator on the model down slightly and stop the model from climbing.

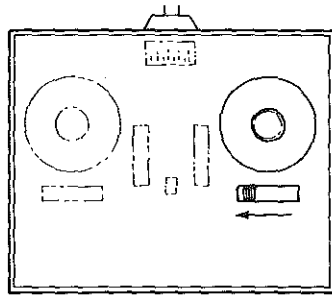

If the model were to **roll** to the right when the control sticks are released, the aileron trim lever would be moved to the left to stop the roll.

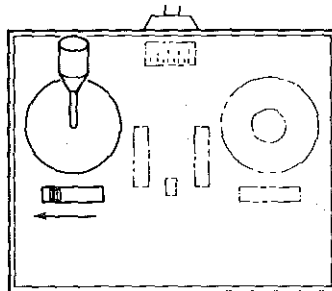

If the model **turned** to the right when the control sticks are released, the Rudder trim lever would be moved to the left until the turn was stopped.

Field Equipment

If you have had the opportunity to see other R/C models being flown, you've probably noticed that the flyers have a **field box** in which they keep all of the things they need to operate their models. Some of the items in a field box are necessary to start and operate the engine. There are also items that flyers put in these boxes that may only be used occasionally, such as tools. What you put in your box will depend on how, and where, you fly. In deciding what is necessary to take to the flying field, you should consider what is necessary to fly your model, make any minor repairs and any adjustments.

The following list consists of the **minimum** equipment necessary to fly an R/C model. You may wish to add to this list. Your hobby dealer will be happy to show you these items.

A Field Box - This can be anything from a cardboard box to a custom built box with pull-out drawers. However, it should have separate compartments for your transmitter, fuel and tools. There are several commercially made field boxes available. Ask your dealer to show them to you.

A Starting Battery and Glow-Plug Leads - The starting battery is a 1-1/2 volt battery that is used to heat the engine's glow-plug for starting. The **leads** are wires and a clip that connect the battery to the glow-plug.

A dry cell can be used as a starting battery. However, due to the high current drain, a dry cell won't last very long. It is much more economical to purchase a ni-cad rechargeable starting battery from your hobby dealer. Some of these batteries come with the leads attached, and a charger.

Fuel - Fuel comes in different formulations. Check the engine manufacturer's instructions to be sure the fuel you select is compatible with your engine.

Fuel can be purchased in pint, quart, gallon and, in some places, 5 gallon containers. The gallon can is the most common and most economical way to buy fuel.

Warning: Model fuel is made from castor, or synthetic, oil and methanol. It burns with an **invisible** flame. You may not know if you, or your model, are on fire until a great deal of damage is done. For this reason, treat model fuel the same as gasoline. Keep it in a sealed container. **Do not** smoke or light matches near a container of fuel or near a model containing fuel. Read all warnings and cautions on the fuel that you buy.

Fuel Pump - The fuel pump is used to transfer fuel from the fuel can to the fuel tank in the model. There are several manual and electric fuel pumps available. Ask your hobby dealer.

Note: Although not necessary, it would be a good idea to purchase a fuel filter. This device connects to the pick-up line on the fuel pump and will filter out any solid contamination in the fuel that could prevent the engine from starting.

Fuel Line - You will need about three (3) feet of silicon fuel line to connect the fuel pump to the fuel container and the model.

Extra Propellers - Even the best flyers break propellers now and then. So, buy a few extra propellers before going to the flying field.

Note: Propellers can be damaged if they strike the ground, or another object, while the engine is running. Inspect your propeller **every time** you get ready to start the engine. If it is cracked, dented, or pieces are missing, **replace it**. A damaged propeller can fly apart, causing injury.

4-Way Wrench - This is a small socket wrench that is shaped like the letter X. It has four different sizes of socket heads that fit the glow plug and a variety of prop nuts.

Extra Glow Plugs - There are several different kinds and lengths of glow plugs. Check the engine manufacturer's instructions to be sure you select the correct plugs for your engine.

Tools - Your field box should contain screwdrivers and allen head wrenches that fit all of the bolts on your engine and model. Also, it should have a pair of pliers and wrenches that fit all of the nuts on the engine and model.

Paper towels or rags - You should have some disposable rags or paper towels to clean fuel residue from your model, and yourself!

Band-aids - If you should injure yourself while at the flying field, you should at least have some band-aids. A complete first aid kit would be best and could be kept in your car. This is not to say that R/C models are dangerous. When properly operated and safety precautions are taken, they are as safe as any other machine. However, since most flying fields are located in unpopulated areas, it would be wise to have a first aid kit where it's needed, when it's needed.

Radio and Engine Operation

The safe and proper operation of your radio and engine are your responsibility. Read and follow the instructions that come with them. If you have any doubt about their proper operation, seek the help of a qualified individual.

Before attempting to fly your model for the first time, we strongly urge you to join an R/C Club. This will put you in contact with people who understand R/C models and can help you learn to fly.

Radio

Prior to flying your model for the first time, the radio should be **range checked** to be sure that it is broadcasting a signal that is strong enough to reach the model when it is in flight. The exact procedure for range checking a radio will vary depending on the brand of radio that you have. Follow the procedure outlined in the operating instructions for your radio. If none are given, the following general procedures can be used to range check, and verify, that your radio is operating properly.

1. If the antenna on the transmitter is removable, remove it. If it is not removable, collapse the antenna.

Note: Some transmitters with removable antennas warn against operating the transmitter with the antenna removed. In that case, collapse the antenna.

2. Turn on the transmitter and the receiver.

Important: Before turning on the transmitter, be certain that there are no other transmitters operating on the **same** frequency. At most flying sites, frequency usage is controlled by colored clothes pins that are clipped to a pole. In order to turn on your transmitter, you **must** have the clothes pin with your frequency colors **in your possession**. By following this procedure, only the person with the clothes pin for a specific frequency can turn on a transmitter for that frequency. This method of frequency control prevents accidental interference that could cause a crash. Frequency control procedures vary at different flying sites. Ask about the procedures at the field you intend to fly from **before** operating your radio at that field.

3. Move all of the controls to be sure that they are all functioning.
4. Move away from the model until the control surfaces start to move, or chatter, on their own or; until you cannot control any **one** of the functions with the transmitter. This distance will vary with the brand of radio and is usually between 30 to 100 feet. If it is less than 10 feet, something is wrong. **Do not** attempt to fly the model. Send the radio back to the manufacturer for inspection.

Engine

The following list outlines general safety procedures. We urge you to seek the help of a qualified individual to assist and instruct you in proper starting and operating procedures.

Warning: If you have never operated a model aircraft engine, we strongly urge you to seek the help of a qualified individual. These engines have a great deal of power for their size and are capable of inflicting serious injury if improperly operated. Read and follow all of the manufacturer's warnings and cautions.

1. Be certain that your radio is operating properly **before** starting the engine.
2. Inspect the propeller **prior** to starting the engine. Do this **every** time you get ready to start an engine. Damaged propellers can fly apart and cause serious injury.
3. Check the security of the prop nut before starting an engine. A loose prop nut could cause the propeller to fly off the engine.
4. Periodically check the motor mount bolts to be certain they are tight.
5. Never reach over, or around, a propeller when it is turning.
6. Always stand behind the propeller to make engine adjustments when the engine is running.
7. When starting the engine, have someone hold the model so that it can't move.
8. Always point the tail of the model **away** from people and other models so that any debris thrown back by the prop blast will not cause injury or damage.

Your First Flight

Although it's possible to learn to fly an R/C model without any help, the odds of success are very slim. The people who have done this very often have had a good knowledge of aerodynamics, good hand-eye coordination and some prior experience flying free-flight models. Even if you have these qualifications, we still recommend that you have an experienced R/C flyer assist you with your first flights. You have devoted a great deal of time and effort to building your Aero-Star and it would be a shame to crash it on the first flight simply because someone was not available to check out your equipment and flight trim your model. Don't be afraid to ask for help. At one time everyone was a beginner and knows that you will have questions and problems. Most of the people in this hobby are more than willing to help. All you have to do is ask.

How long does it take to learn to fly? That's up to you. Some people learn to fly in a day, while others take months. People learn at different rates and it has nothing to do with whether or not they will become good fliers. It's just human nature. If your model and radio are in proper working order when you go to the flying field, you won't waste any time and should progress rapidly. Learning to fly an R/C model airplane is a lot like learning to play the piano. It takes practice. So, don't worry about how long it takes, concentrate on how well you learn.

Preventive Maintenance

There have been several references and warnings in this manual concerning the effects of vibration on various components. On a long term basis, vibration can eventually loosen any screw. With that in mind, it would be wise to periodically inspect all of the screws and linkages in your Aero-Star. If you do this, it is very unlikely that you will ever have a model crash because something came loose.

To help minimize engine vibration, propellers can be balanced. There are several brands and kinds of prop balancers available from your hobby dealer and we recommend that you purchase one. It will last a lifetime and will add greatly to the service life of your models and radios.

It would also be wise to remove the exhaust residue from your Aero-Star after every flying session. This residue is mostly oil, and if allowed to remain on your model, will eventually soak into the wood through small openings. Oil that gets into the wood can loosen glue joints over a period of time. There are several airplane **cleaners** available from your hobby dealer for this purpose. If you can't locate any of them, rubbing alcohol or Windex will cut the oil and you can remove it with a paper towel or rag.

We at Midwest Products hope you have enjoyed building your Aero-Star, and sincerely wish you the best of times flying it. We would appreciate your taking a few minutes to fill out and return the postage-paid evaluation card in this manual. We welcome any suggestions or comments you may have for improving our kits and instructional material.

Thank you