

Fuel tank located by rubber bands on eyelets

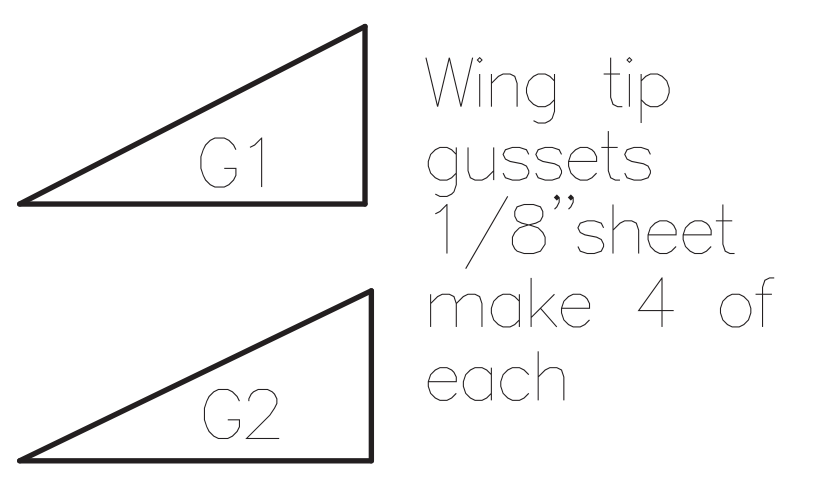
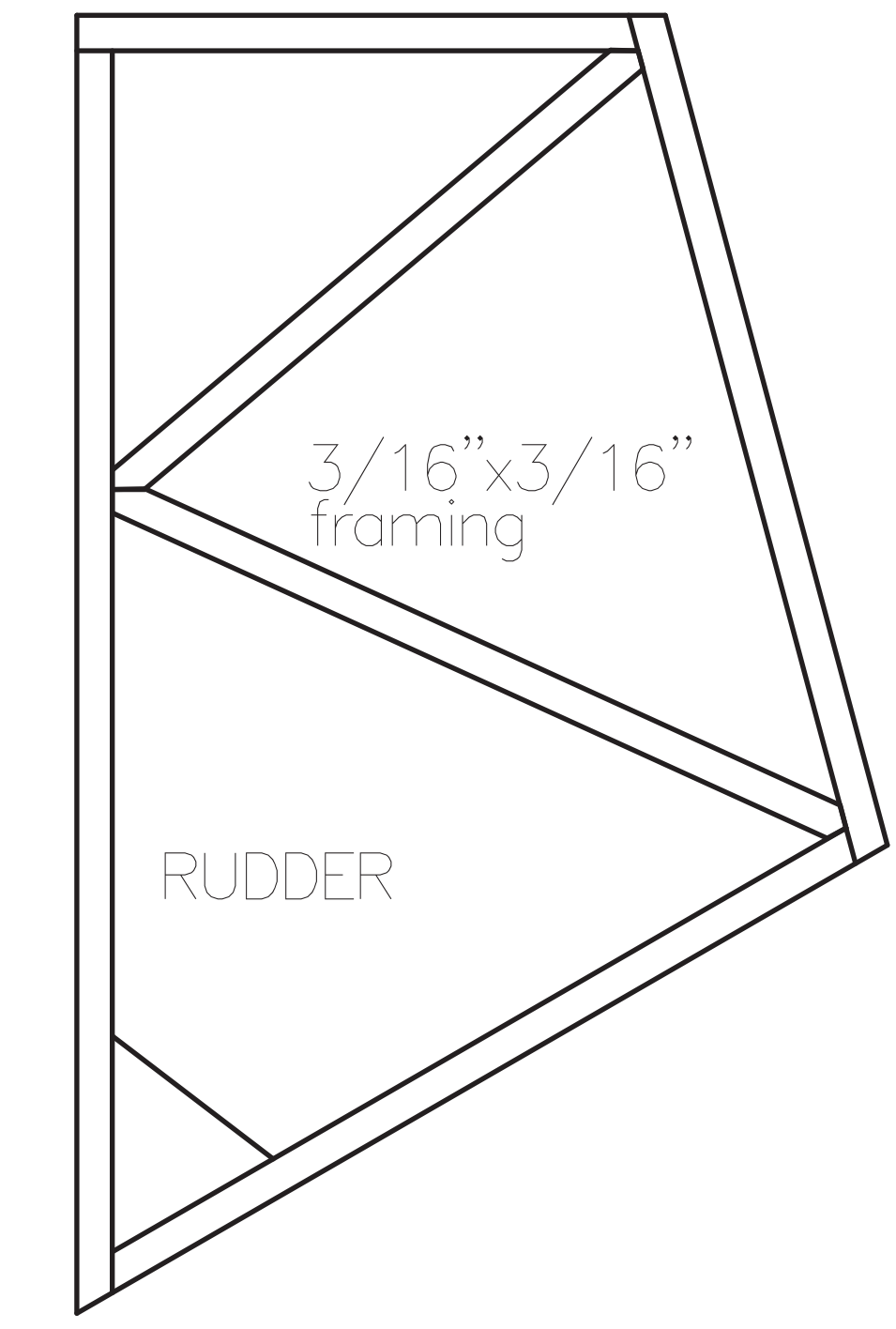
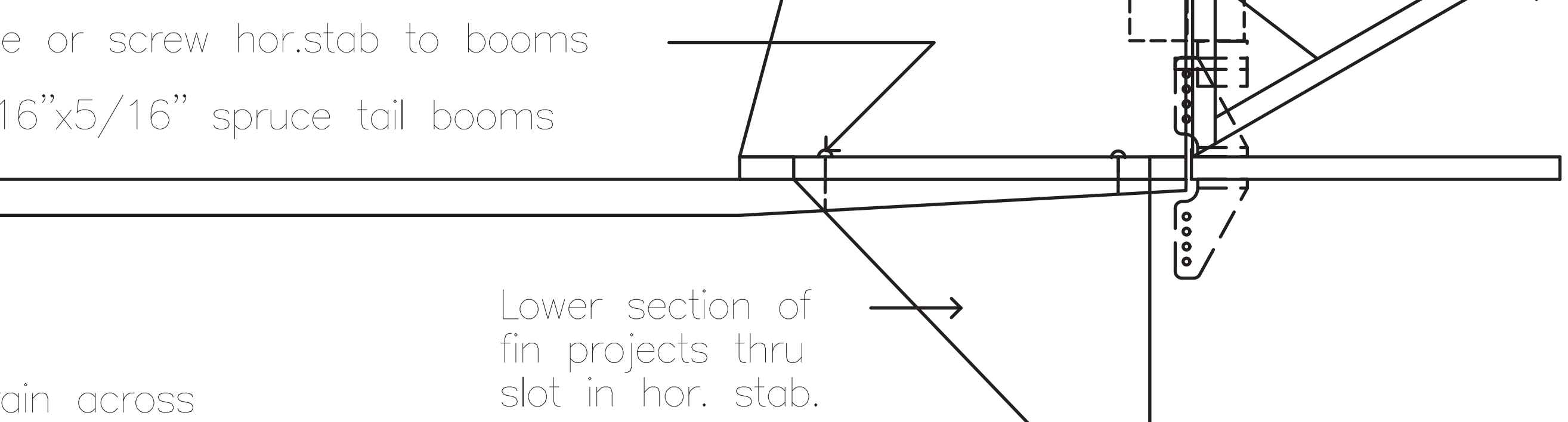
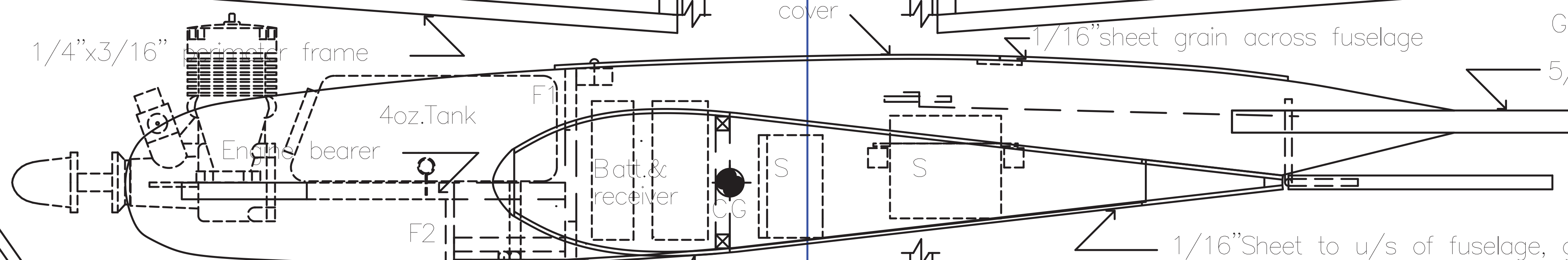
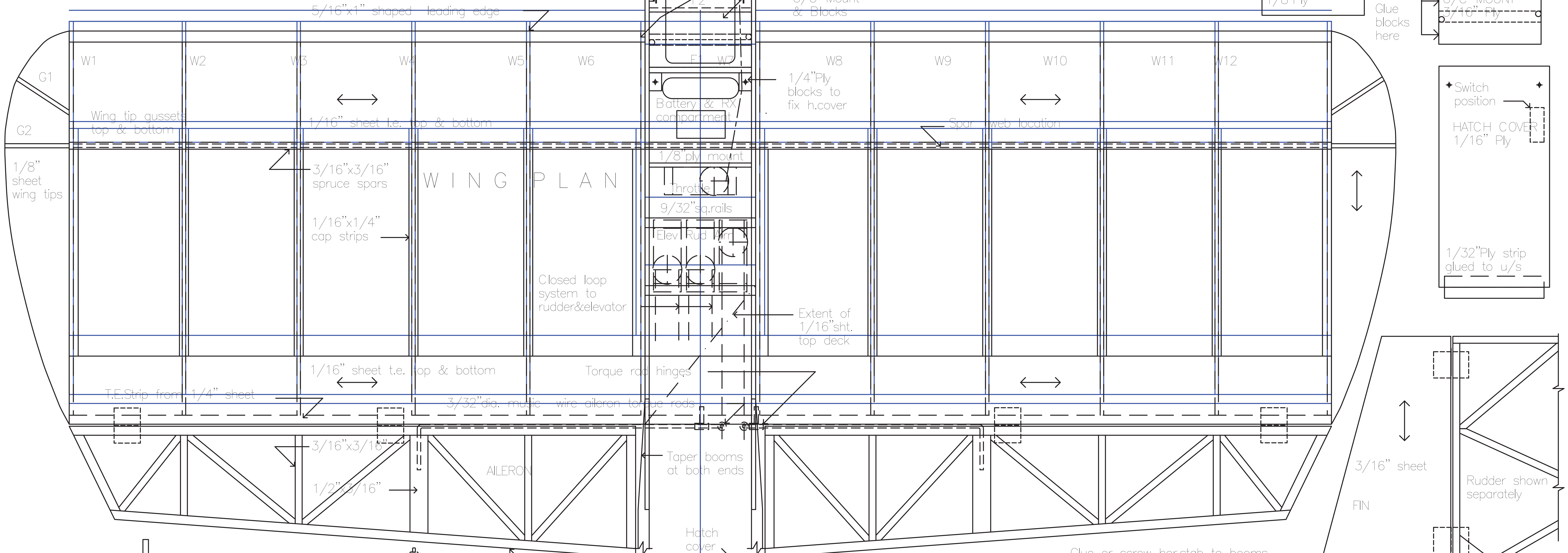
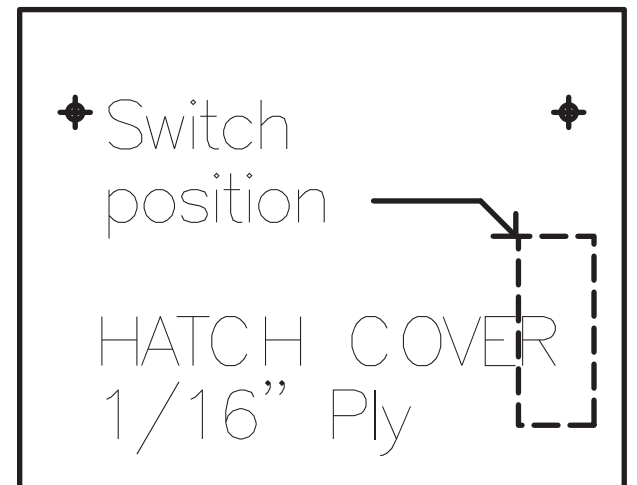
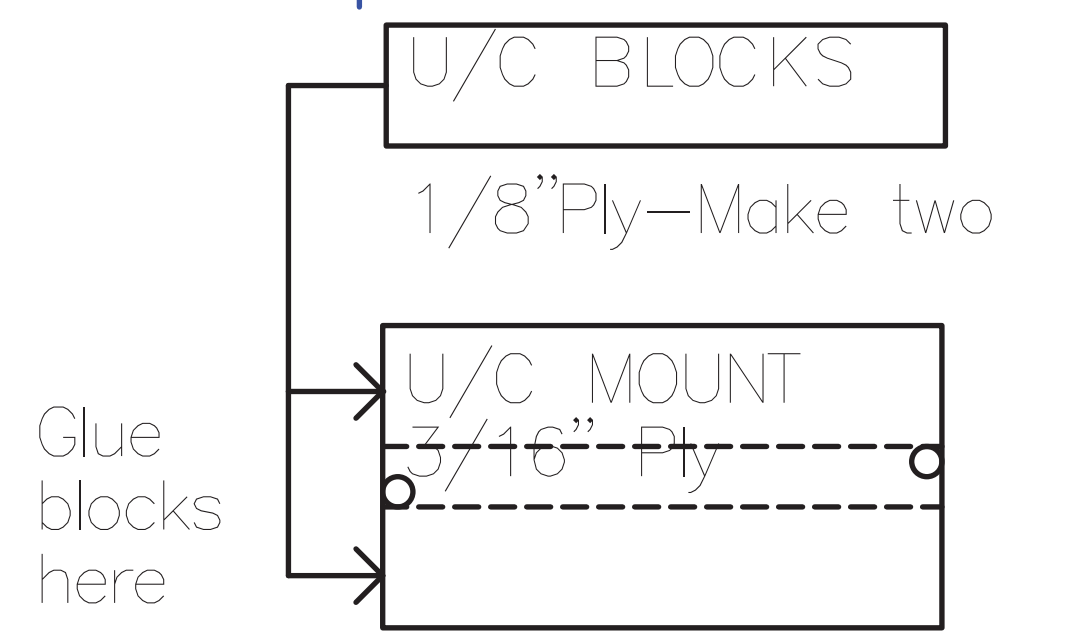
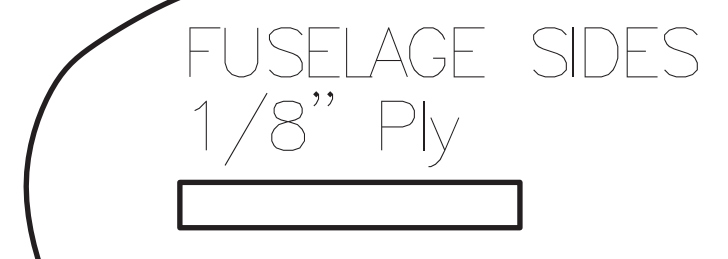
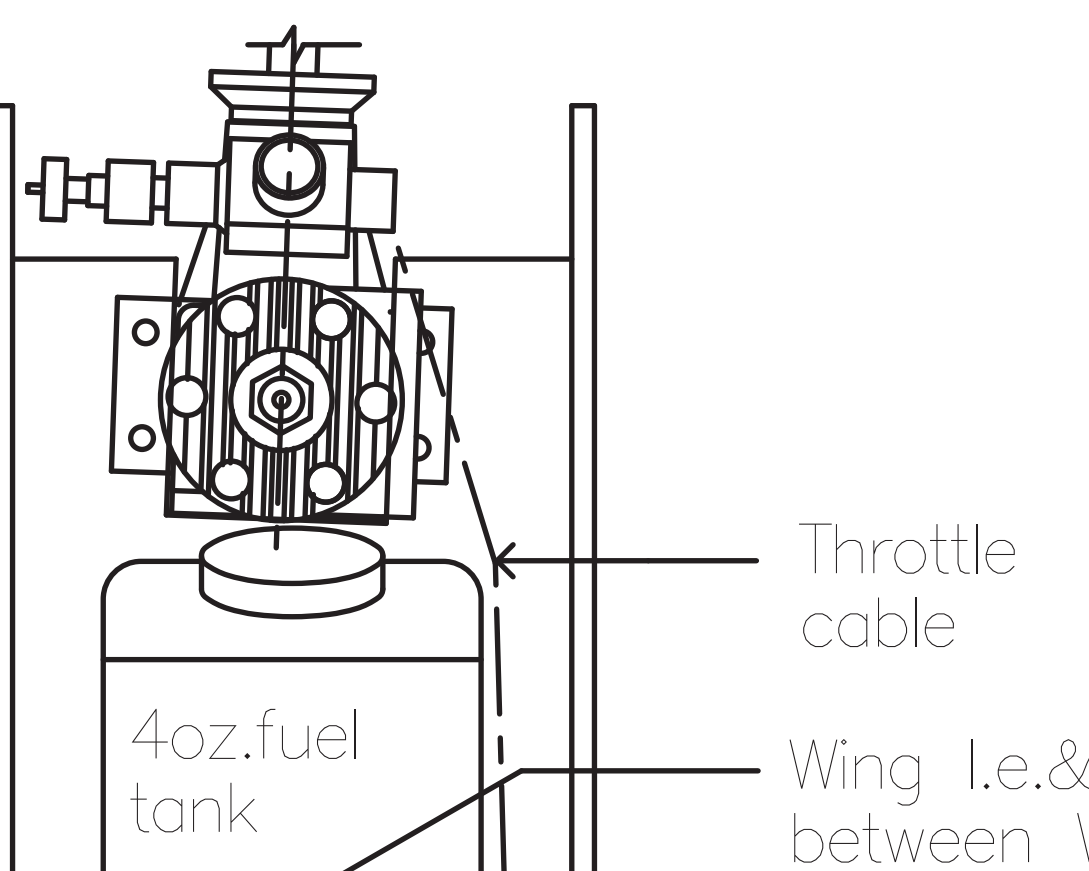

WING RIB  
W1,W6,W7,W12 are 1/8" balsa  
All others 3/32" balsa

NOTES  
Hinge positions  
Dubro Kwik Hinges recommended  
Direction of grain indicated by arrow  
All wood balsa unless otherwise noted

**FUNSTAR**

25 powered funfly model  
span:39.6", area:526sq.in.  
wt.:3lbs.,w.lnq:11oz./sq.ft.  
designed&drawn : F.Burman