

PIPER COMANCHE
 MA 317 P.M.H. LEWIS 4'6"
 LENGTH 24" SPAN 36"
 ENGINE .75-1 CC
 MODEL AIRCRAFT 1959
 17-20 NOEL ST LONDON W1

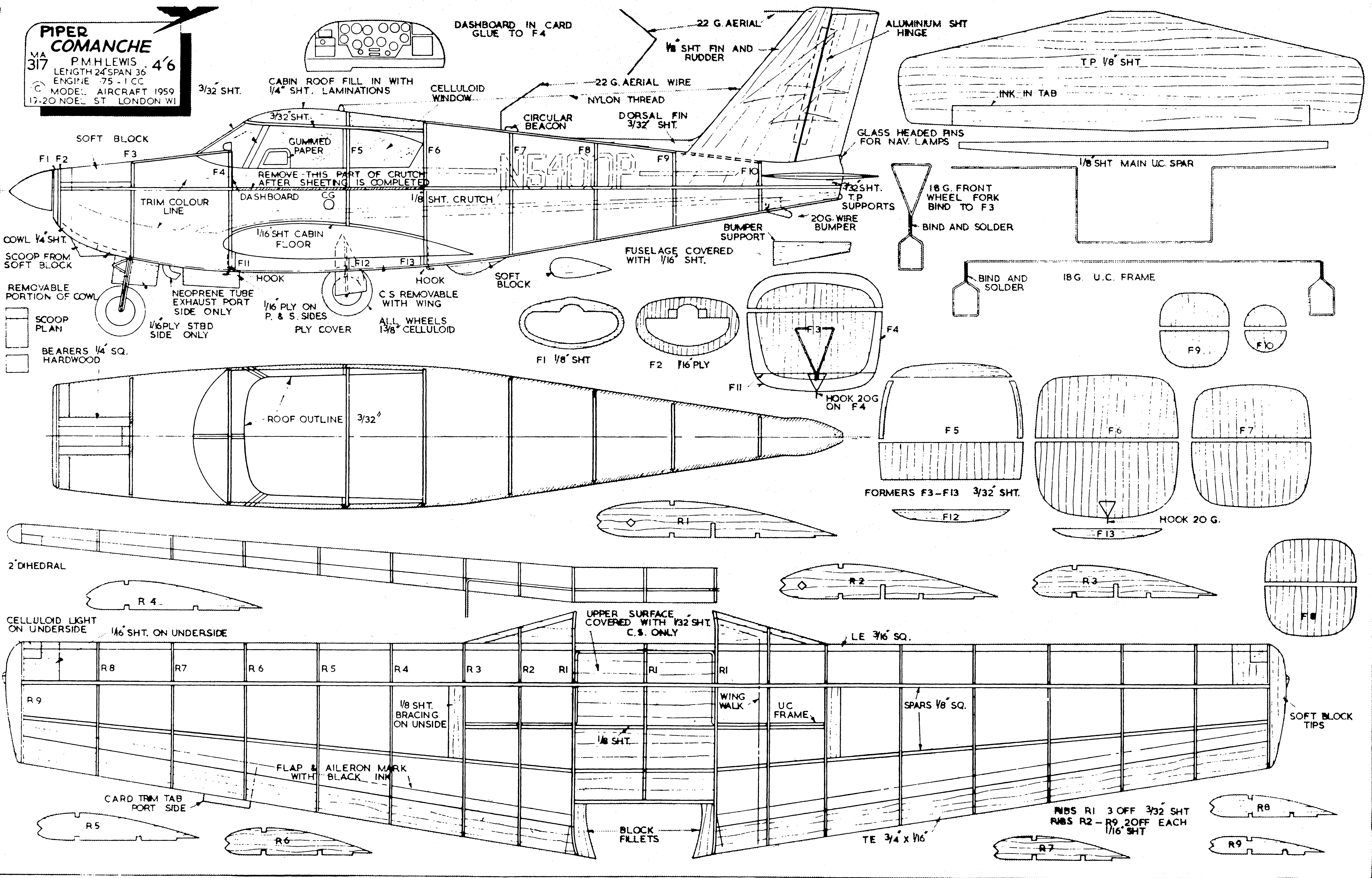

DASHBOARD IN CARD
 GLUE TO F4

22 G. AERIAL
 1/8 SHT FIN AND
 RUDDER

ALUMINUM SHT
 HINGE

T.P. 1/8 SHT

3/32 SHT.
 CABIN ROOF FILL IN WITH
 1/4 SHT. LAMINATIONS

CELLULOID
 WINDOW

22 G. AERIAL WIRE
 NYLON THREAD
 DORSAL FIN
 3/32 SHT.

GLASS HEADED PINS
 FOR NAV. LAMPS

INK IN TAB

SOFT BLOCK
 F1 F2 F3

GUMMED
 PAPER F5 F6

CIRCULAR
 BEACON

DORSAL FIN
 3/32 SHT.

1/8 SHT MAIN UC SPAR

REMOVE THIS PART OF CRUTCH
 AFTER SHEETING IS COMPLETED

DASHBOARD
 CG

1/8 SHT. CRUTCH

3/32 SHT.
 T.P.
 SUPPORTS

18 G. FRONT
 WHEEL FORK
 BIND TO F3

COWL 1/4 SHT.
 SCOOP FROM
 SOFT BLOCK

1/16 SHT CABIN
 FLOOR

BUMPER
 SUPPORT

20G. WIRE
 BUMPER



REMOVABLE
 PORTION OF COWL

NEOPRENE TUBE
 EXHAUST PORT
 SIDE ONLY

1/16 PLY ON
 P. & S. SIDES
 PLY COVER

C.S. REMOVABLE
 WITH WING
 ALL WHEELS
 13/8" CELLULOID

FUSELAGE COVERED
 WITH 1/16 SHT.

BIND AND
 SOLDER

18G. U.C. FRAME

SCOOPLAN
 BEARERS 1/4 SQ.
 HARDWOOD

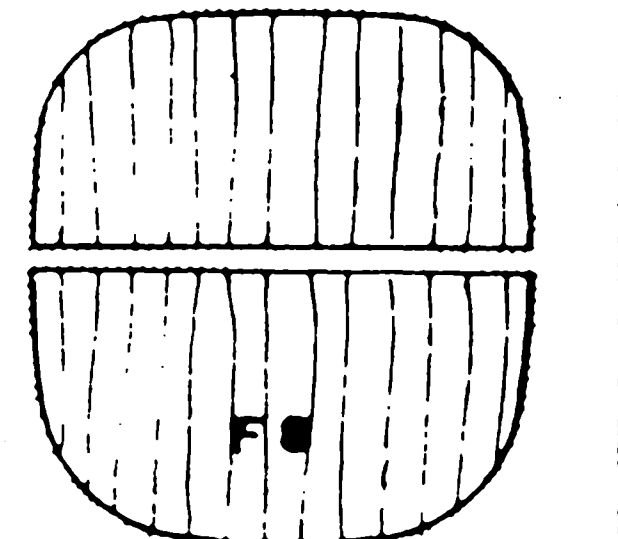
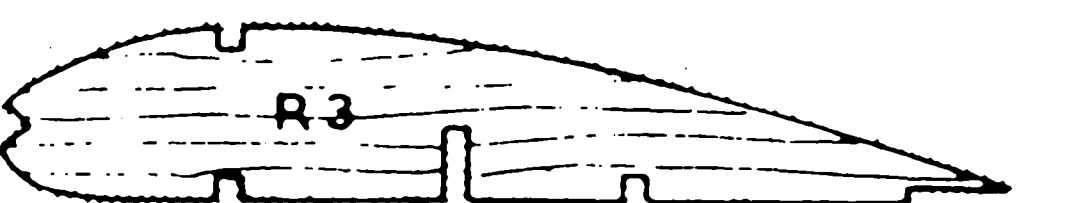
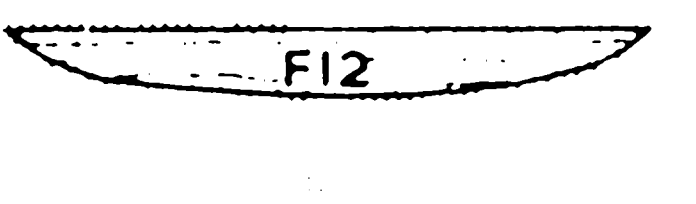
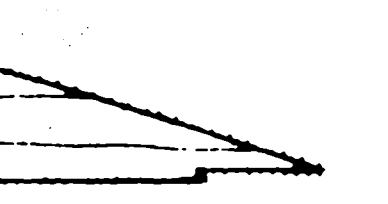
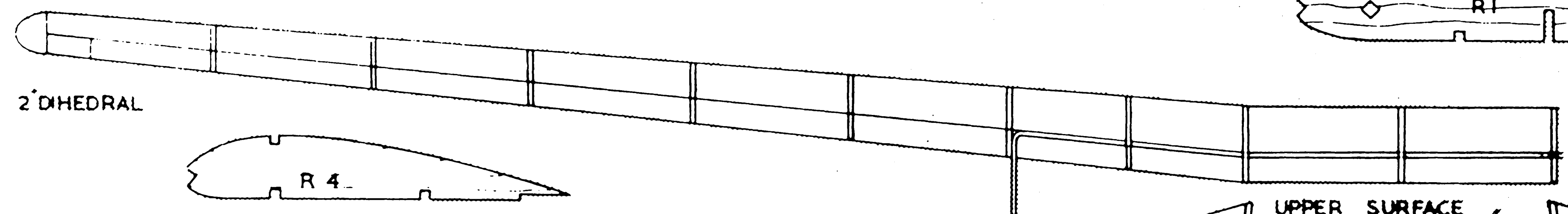
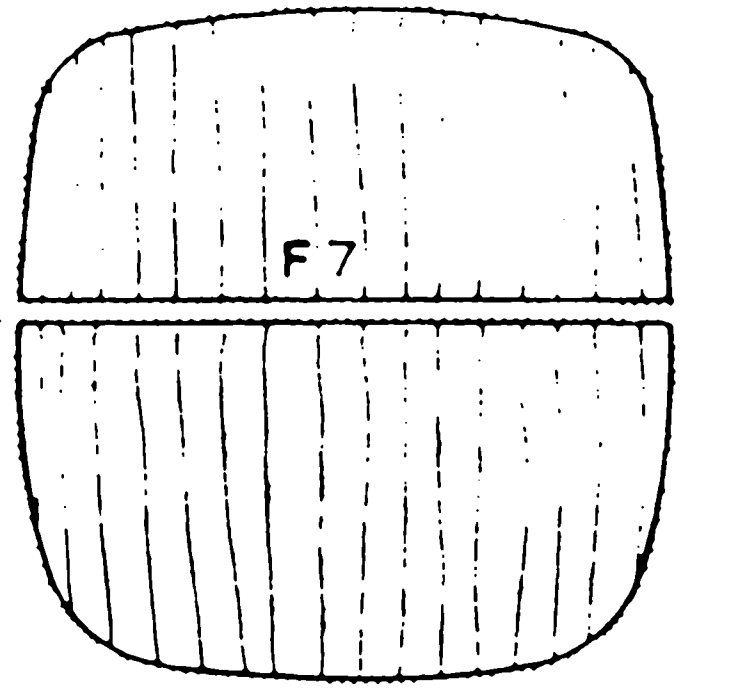
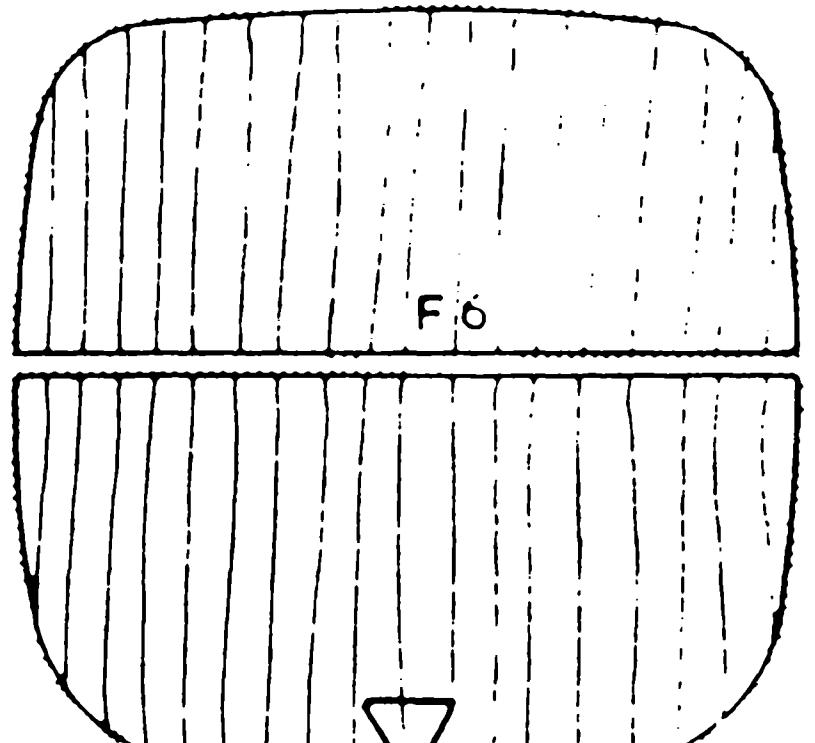
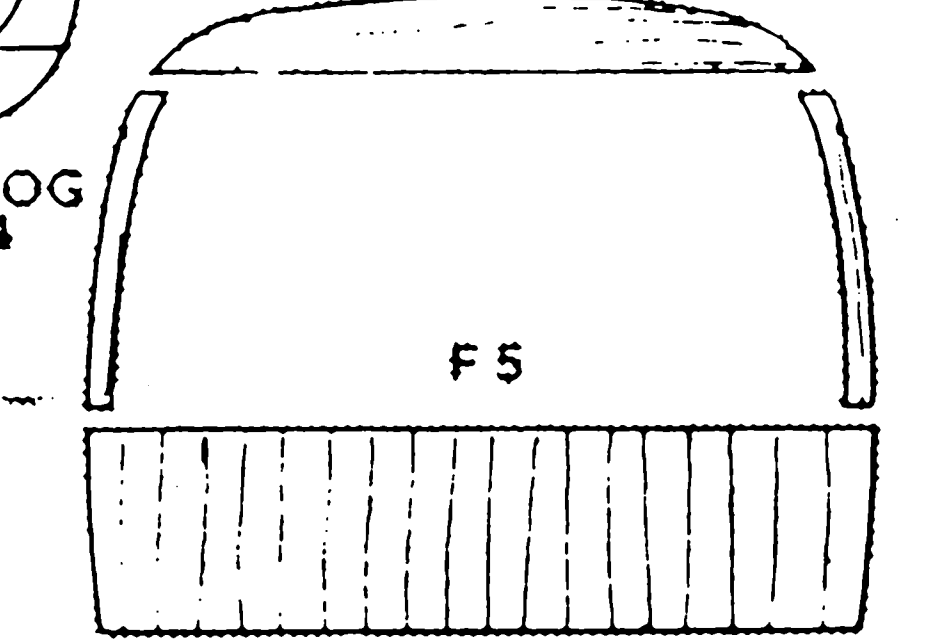
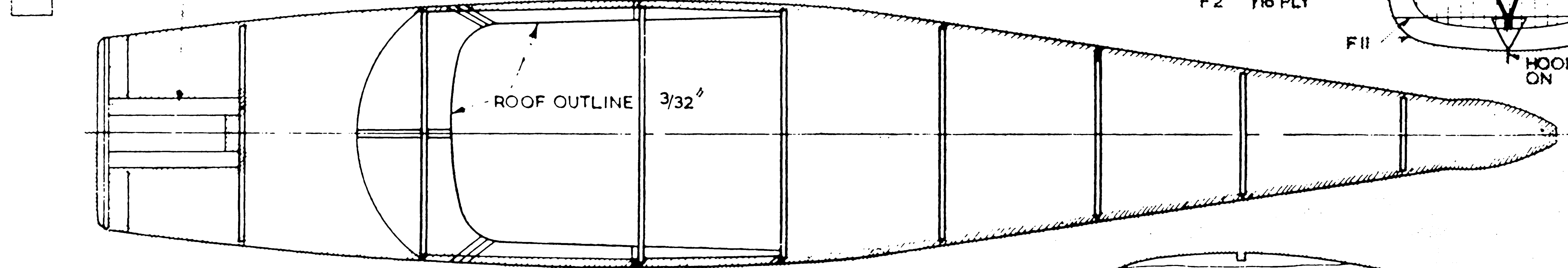
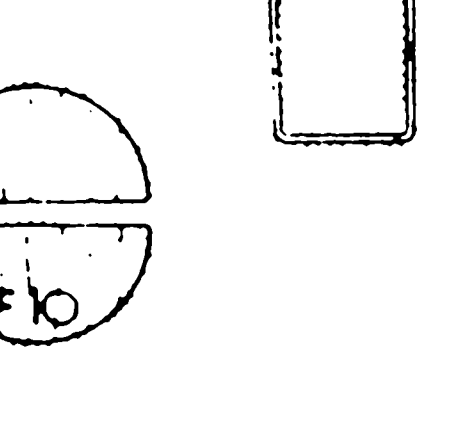
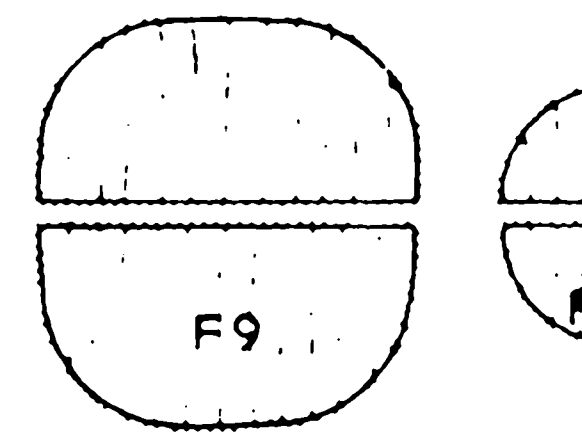
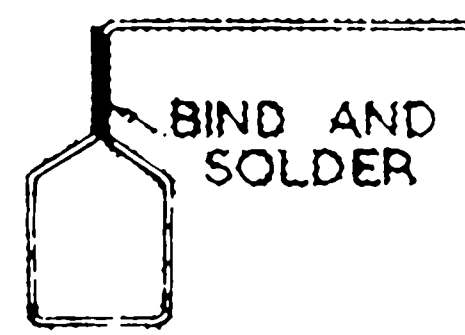
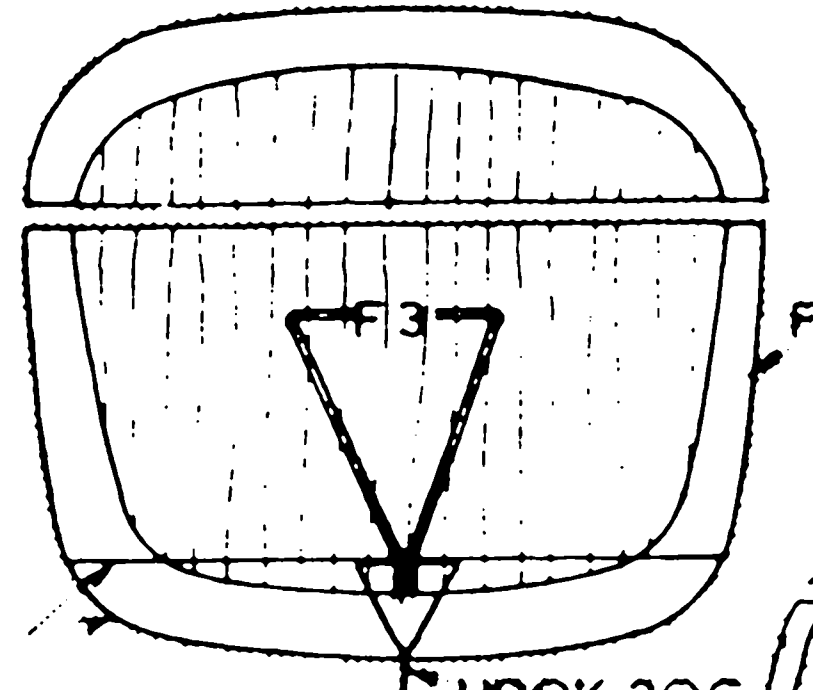
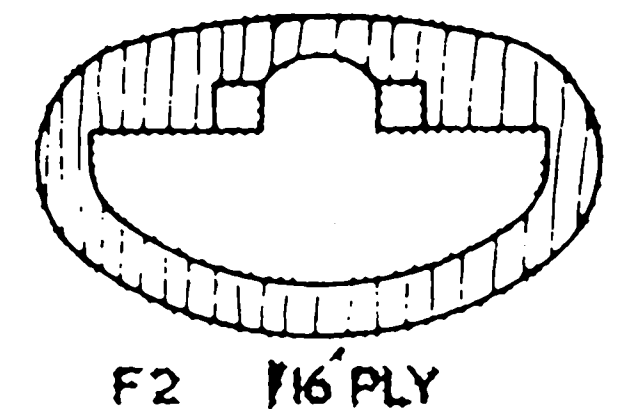
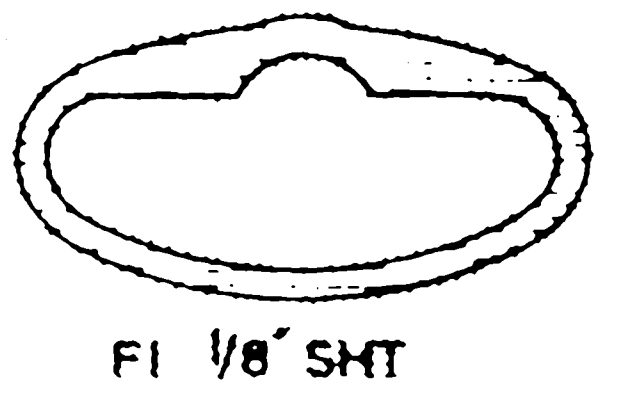

CELLULOID LIGHT
 ON UNDERSIDE
 1/16 SHT. ON UNDERSIDE

UPPER SURFACE
 COVERED WITH 1/32 SHT
 C.S. ONLY

LE 3/16 SQ.

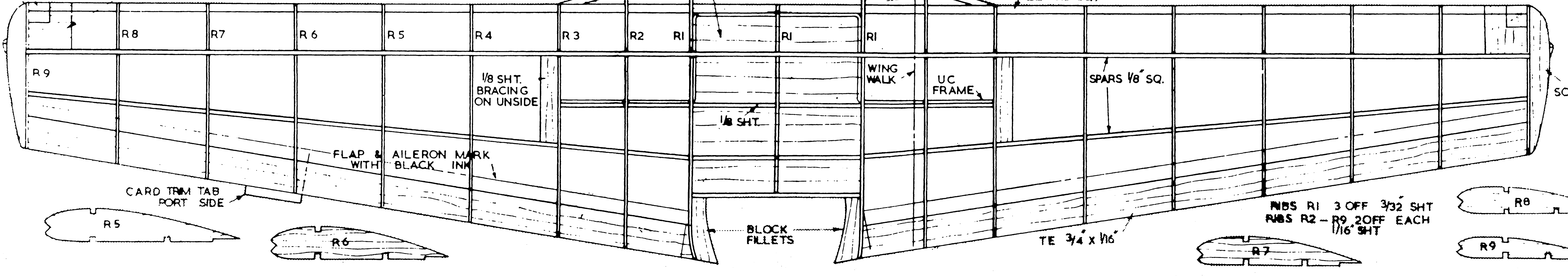

1/8 SHT.
 BRACING
 ON INSIDE

WING
 WALK

UC
 FRAME

SPARS 1/8 SQ.

SOFT BLOCK
 TIPS

FLAP & AILERON MARK
 WITH BLACK INK

CARD TRIM TAB
 PORT SIDE

BLOCK
 FILLETS

TE 3/4 x 1/16

MBS R1 3 OFF 3/32 SHT
 MBS R2 - R9 2 OFF EACH
 1/16 SHT

