

CONVERSION

MM.	INS.
0.4	1/64"
0.8	1/32"
1	1/25"
1.2	1/20"
1.5	1/16"
2	1/12"
3	1/8"

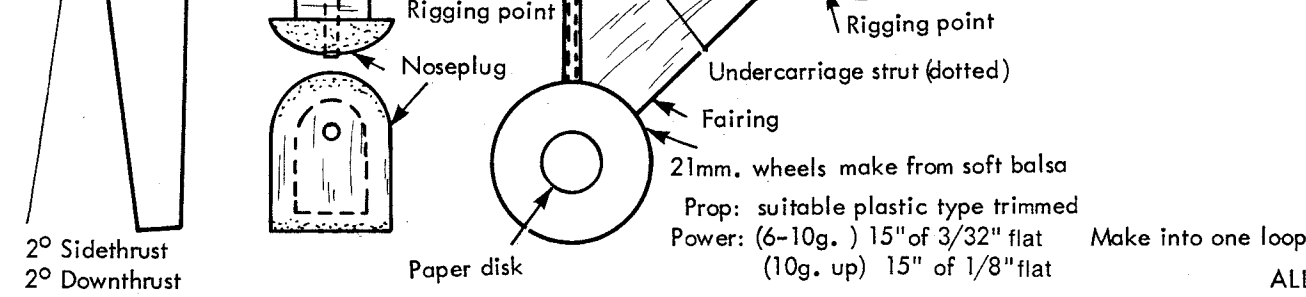
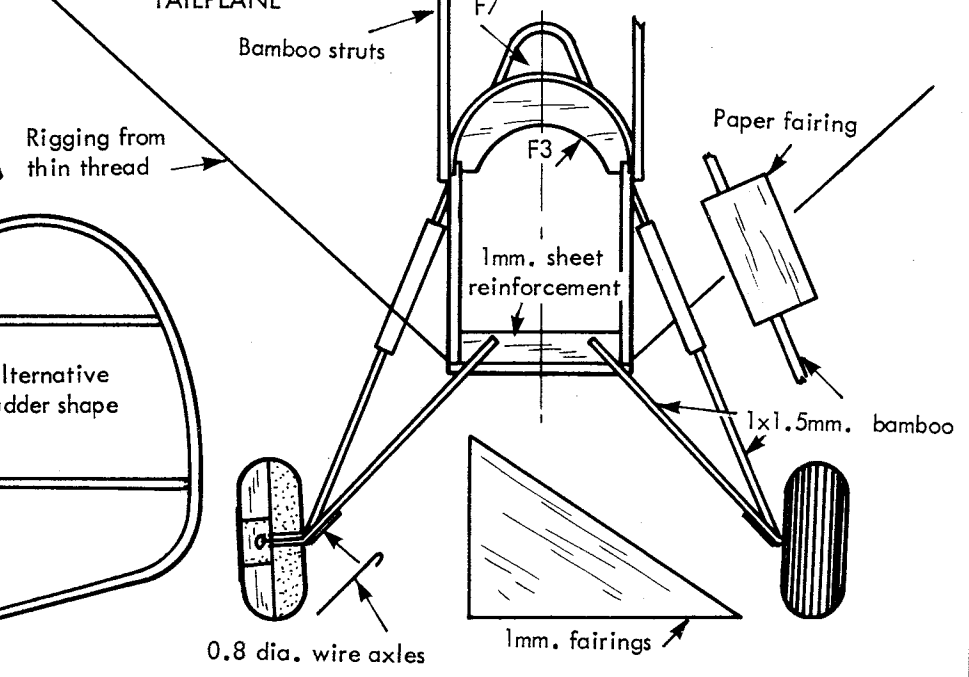
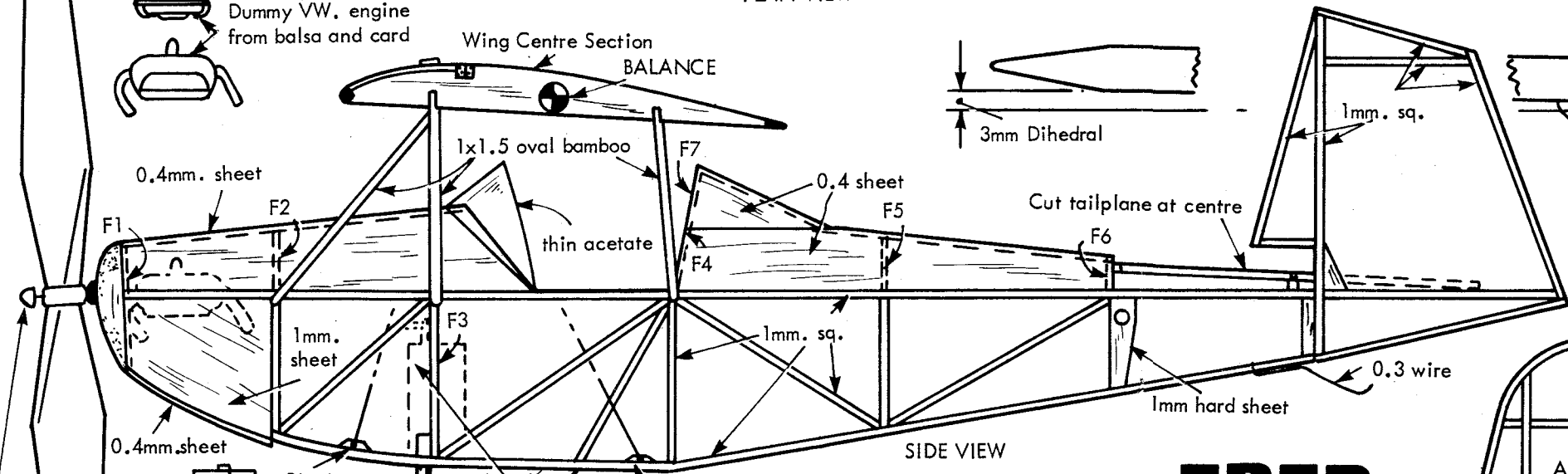
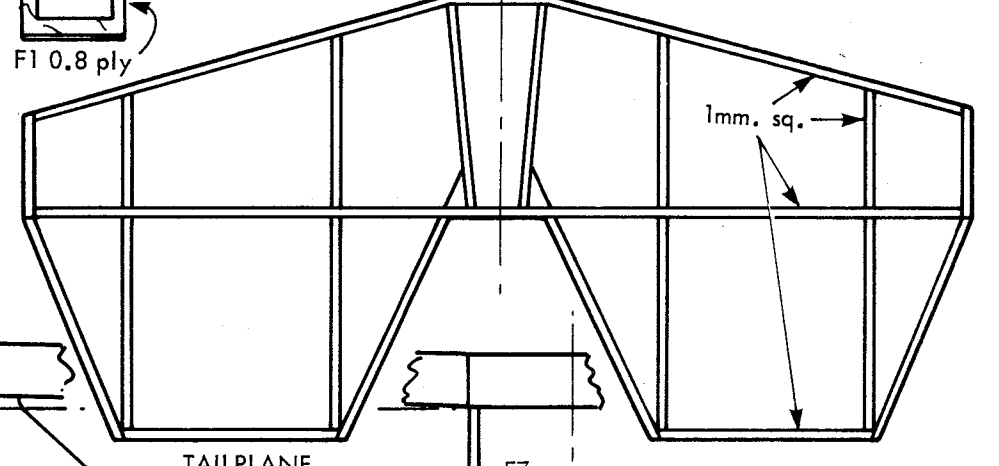
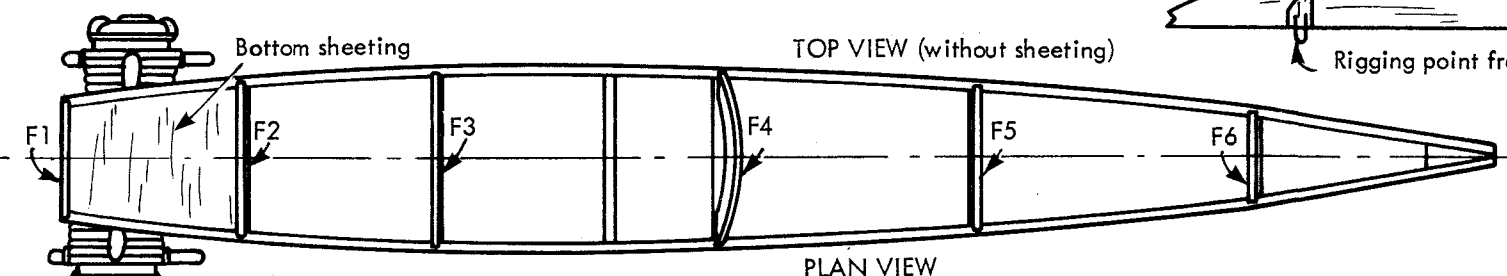
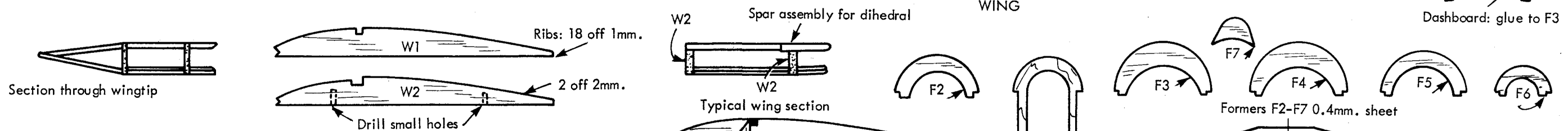
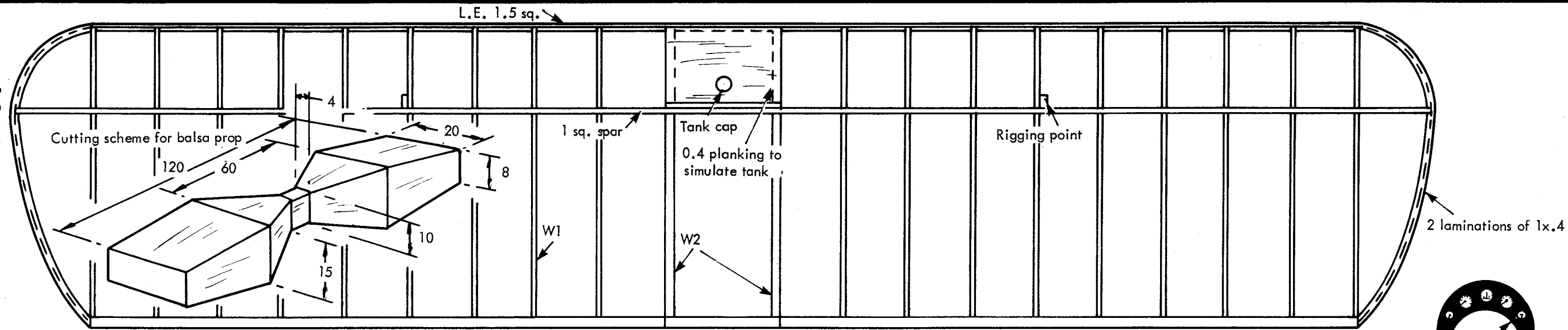

FRED

VW ENGINE POWERED HOME BUILT. Designed by ERIC CLUTTON
 MODEL by SIEGFRIED GLÖCKNER

ALL WOODS ARE BALSA UNLESS OTHERWISE INDICATED

2° Sidethrust
 2° Downthrust