

F1 & F3- 1/16" PLY
 F2,4,5,6- 1/16" Balsa.

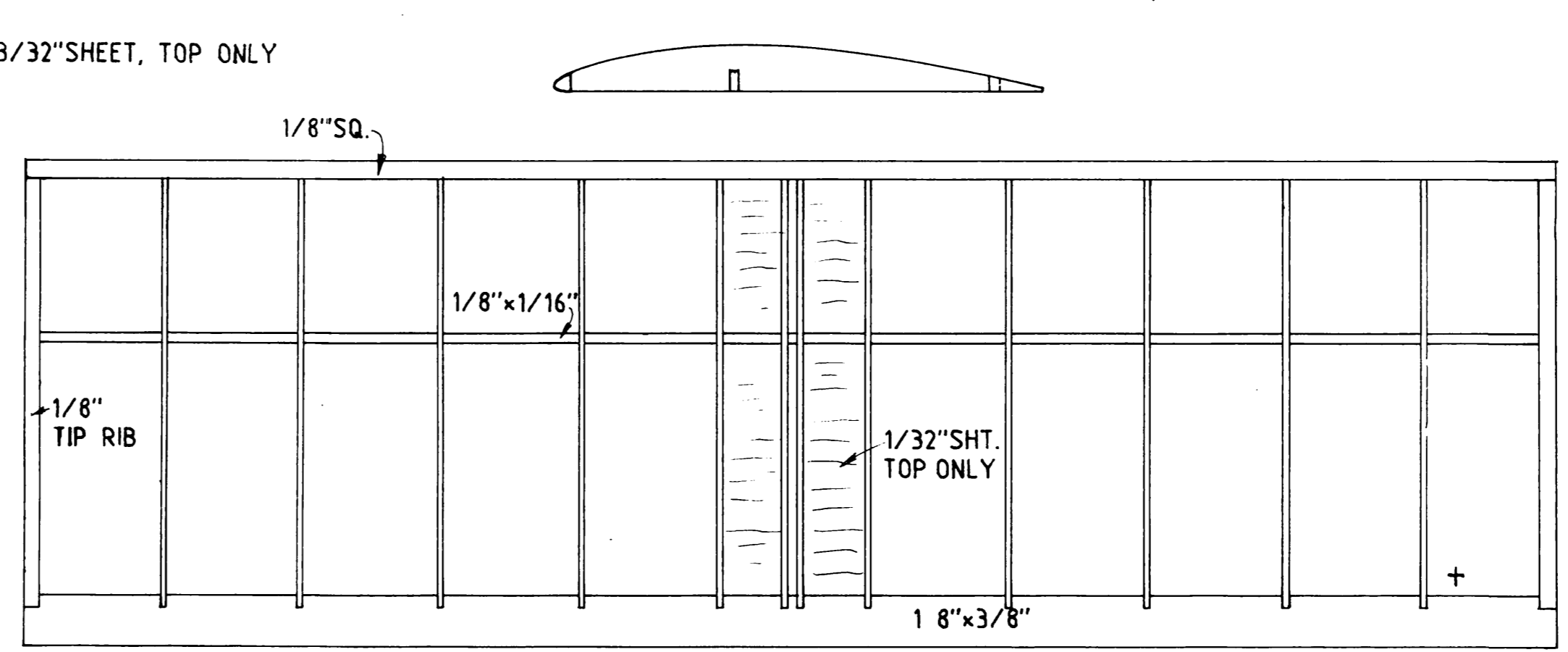
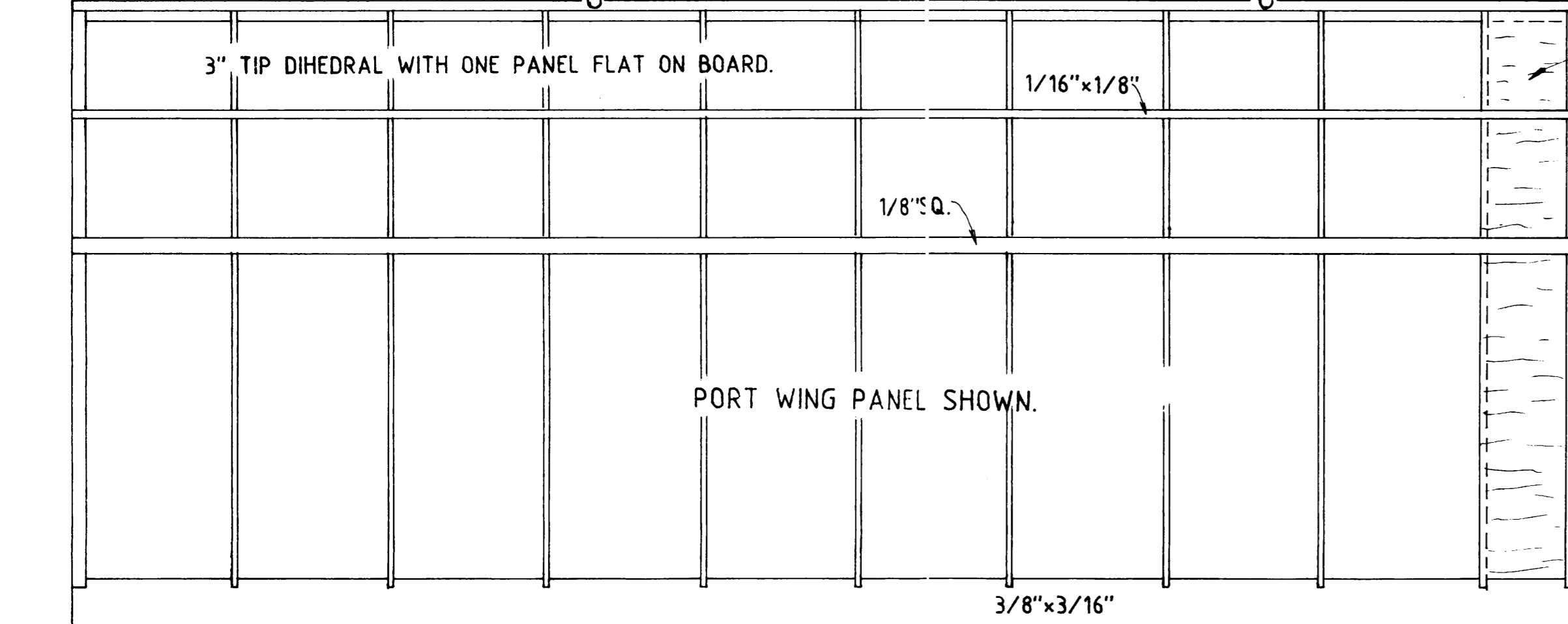
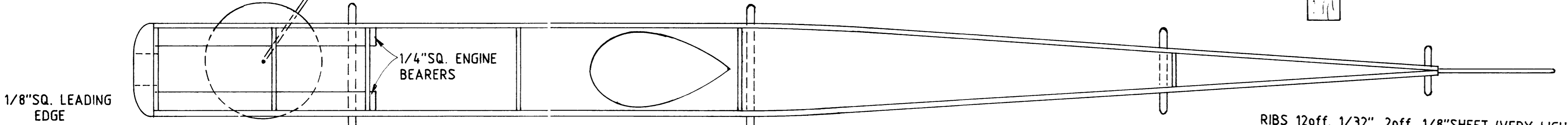

FORTUNE -24" SPAN

DESIGNED BY DES.-CHRIS. EDWARDS

LIST OF BITS.

- 1 SHEET OF Balsa 1/16"x4"x36" MEDIUM.
- 1 SHEET OF Balsa 1/32"x4"x36" MEDIUM.
- 1 STRIP OF Balsa 1/4"x4"x6" SOFT.
- 2 STRIP OF Balsa 1/8" SQ. HARD
- 3 STRIP OF Balsa 1/8"x1/16" MEDIUM.
- 2 STRIP OF Balsa 3/8"x3/16" MEDIUM.
- 1 STRIP OF Balsa 1/8"x3/8" MEDIUM.
- PIECE OF 1/16" PLY 3"x5"
- ENGINE BEARERS 1/4" SQ. x8" LONG.
- ACETATE FOR SCREEN.
- 18S.W.G. PIANO WIRE
- 1 1/2" DIA. S/LINED WHEELS.
- TISSUE OF CHOICE