

CHESHIRE KITTEN



DESIGNED BY
W.A. Pollard
COPYRIGHT OF



THE AEROMODELLER PLANS SERVICE

38, CLARENDON RD., WATFORD, HERTS.

ALL WOODS ARE Balsa UNLESS OTHERWISE STATED.

BARE WEIGHT (LESS MOTOR) : 1 3/4 OZ.

COVER WHOLE MODEL WITH LIGHTWEIGHT MODELSPAN AND GIVE 3COATS CLEAR DOPE

MATERIALS REQUIRED	
1 SHEET OF 1/32" X 3" X 36" MED.	3" X 3" OF 1/16" PLY
1 " " 1/16" X 3" X 36" "	6" OF 1/4" SQ. BEECH
1 " " 1/8" X 2" X 36" "	12" OF 20 SWG. PIANO WIRE
1 STRIP " 1/8" SQ. X 12" HARD	2" " 14" BRASS TUBE
1 " " 3/16" SQ. X 24" "	2" PAXOLIN BELLCRANK

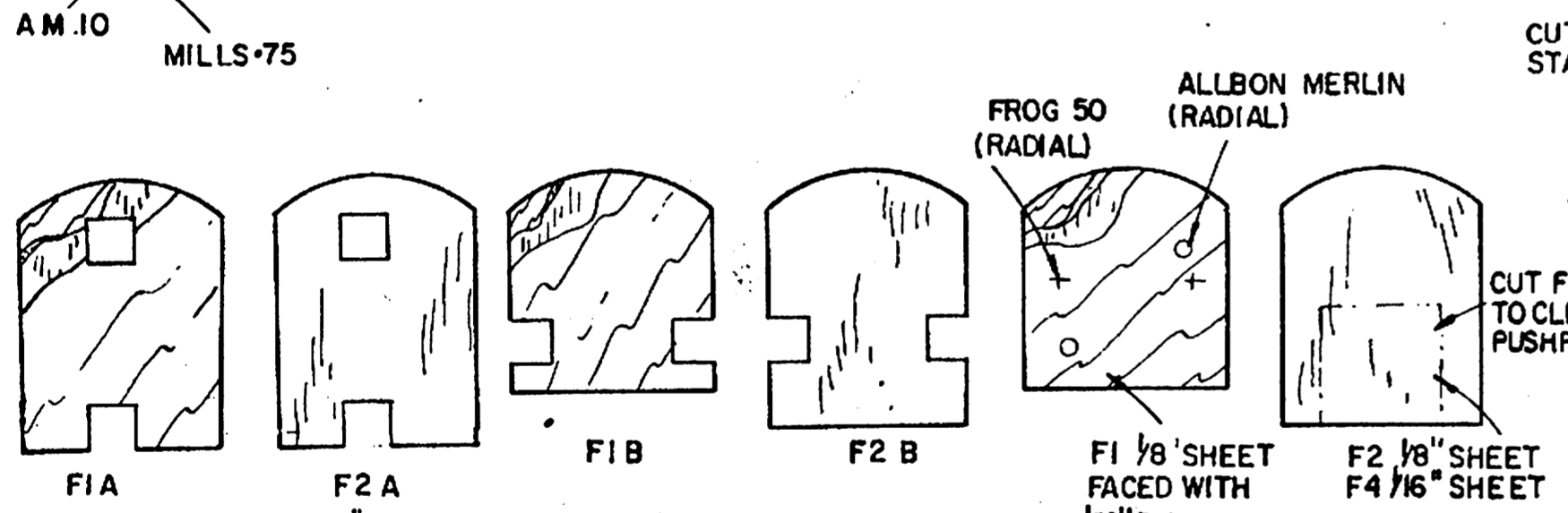
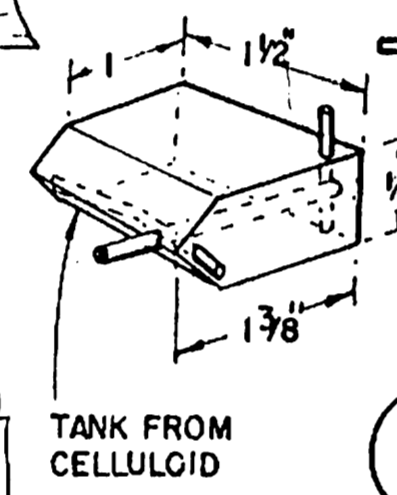
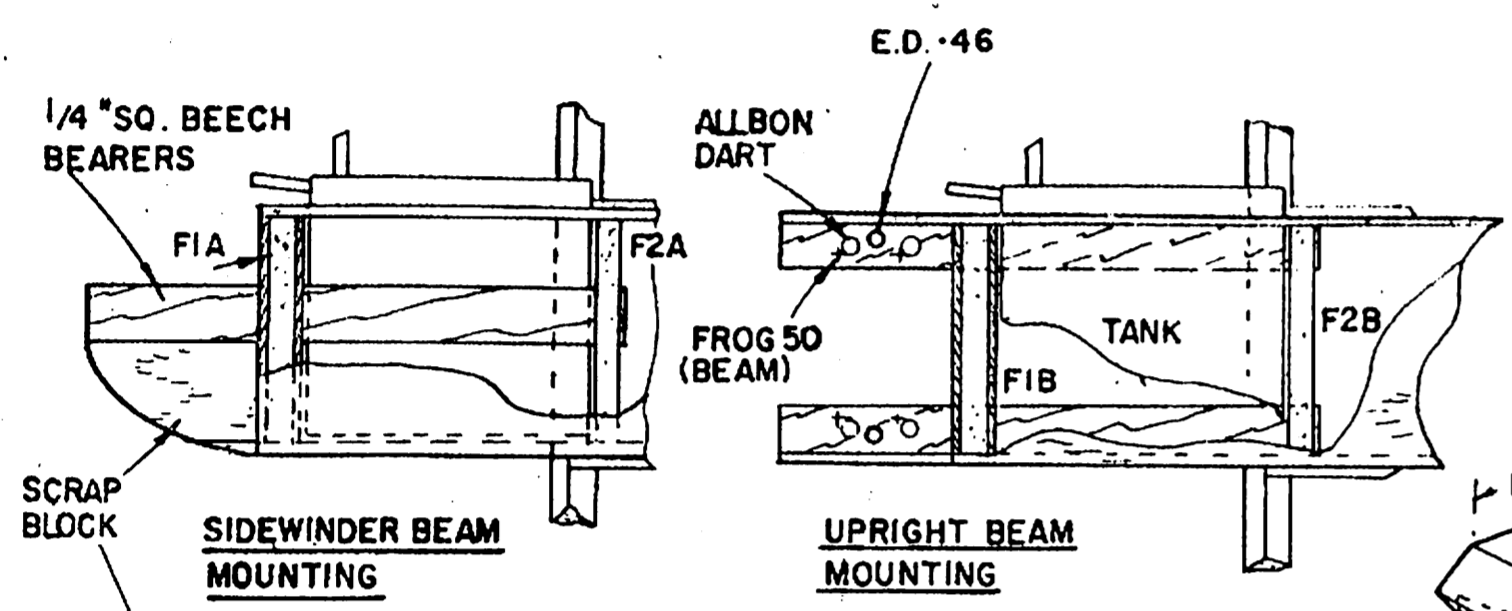
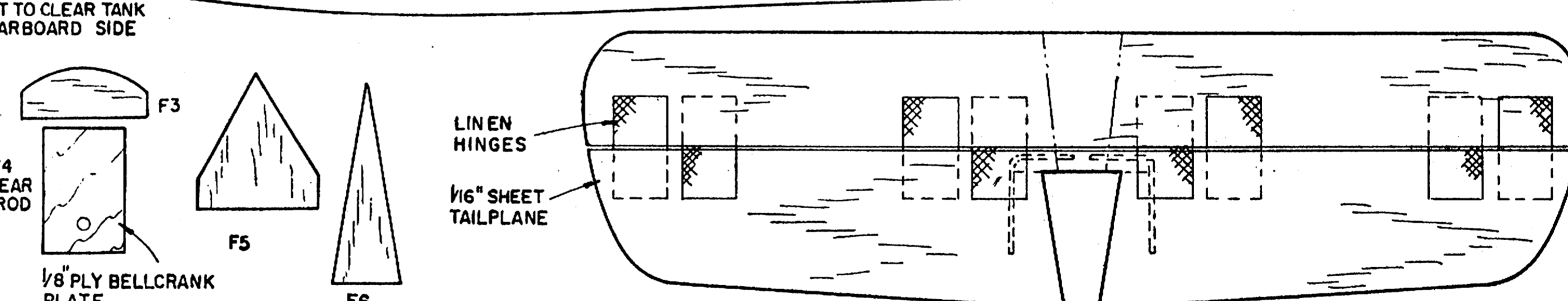
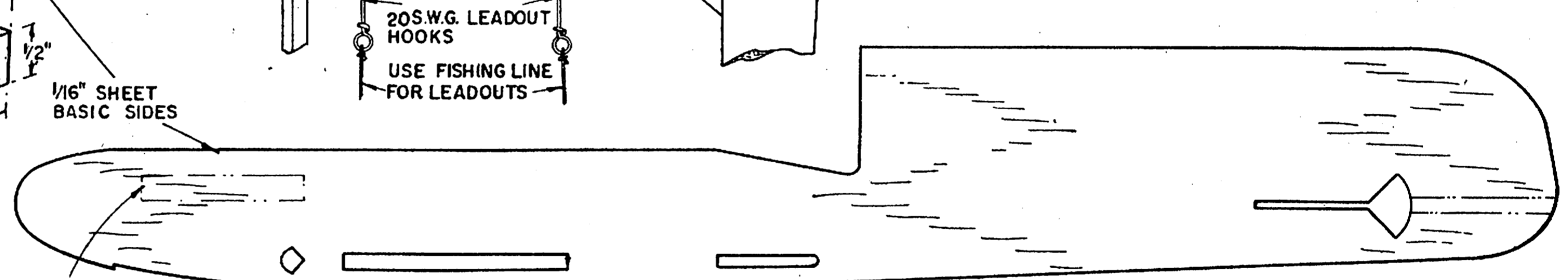
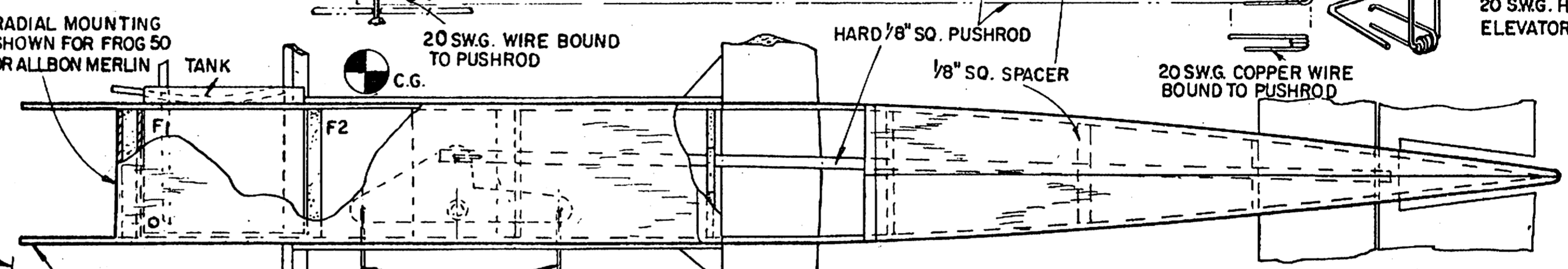
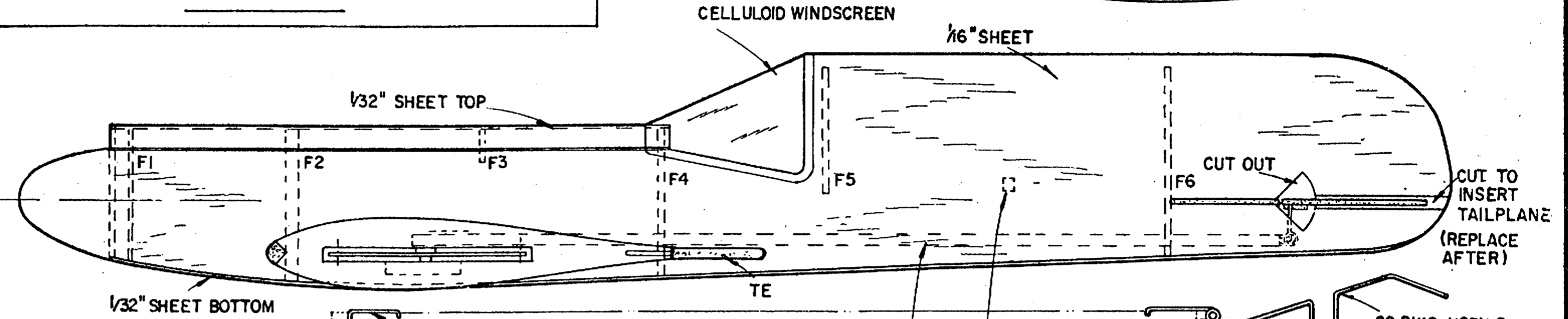
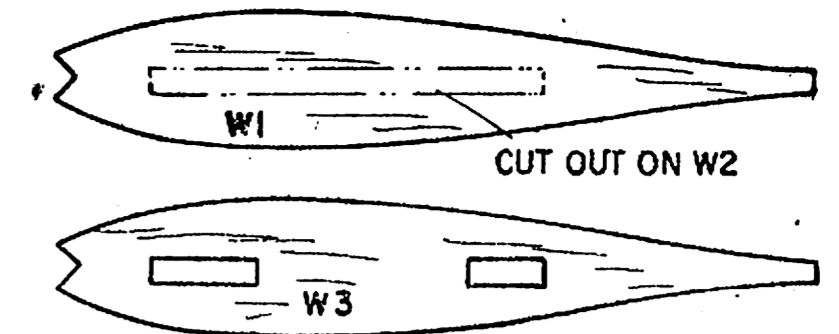

FORMERS: F1, 1A, 1B: 1/8" SHEET FACED WITH 1/16" PLY
F2, 2A, 2B: 1/8" SHEET
F3, 4, 5, 6: 1/16" SHEET

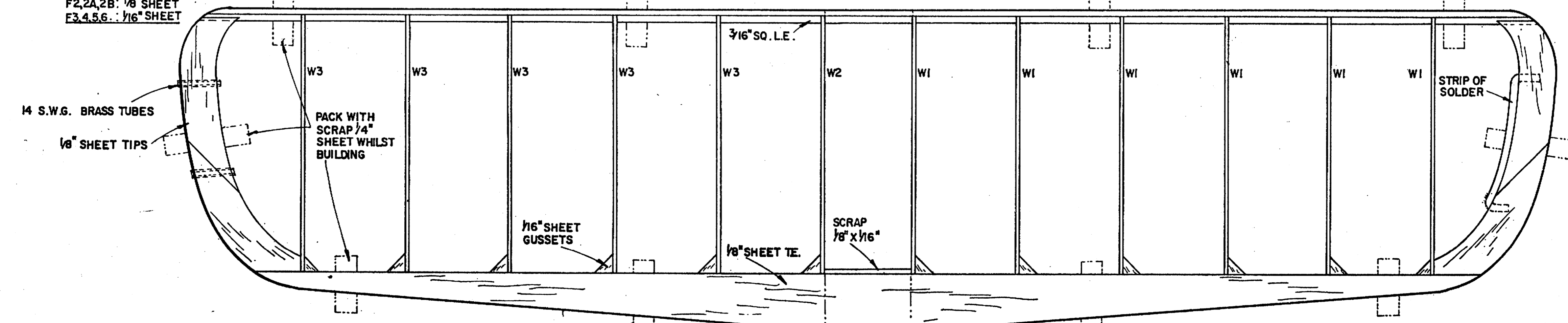

FULL SIZE COPIES OF THIS 1/3rd SCALE REPRODUCTION ARE AVAILABLE PRICE 3/6 FROM AEROMODELLER PLANS SERVICE PLEASE QUOTE PLAN NUMBER CL 693 AND ADD 6d POSTAGE WHEN ORDERING