

Wing:
Leading Edge: 1/6" x 1/16" firm
Ribs: 1/32" light sheet, exc. 1/20" light sheet as indicated at cabane and strut attach points
Trailing Edge: 1/16" x 1/8" medium
Tips: 2 laminations light 1/32" x 1/16"
Cabane & Strut Attach Points: 1/8" block

MISCELLANEOUS:

Gear Legs: 1/8" x 1/20" firm
Wheels: 2 laminations 1/20" light, bush w/ 1/16" birch dowel

Cowl: 1/32" x 1/64" very light
Nose Block: Soft balsa, hollowed
Cylinders: Williams Bros., 1/2" scale
Propellor: Peck Polymers 4-3/4"
Interplane Struts: 1/8" x 1/20" medium

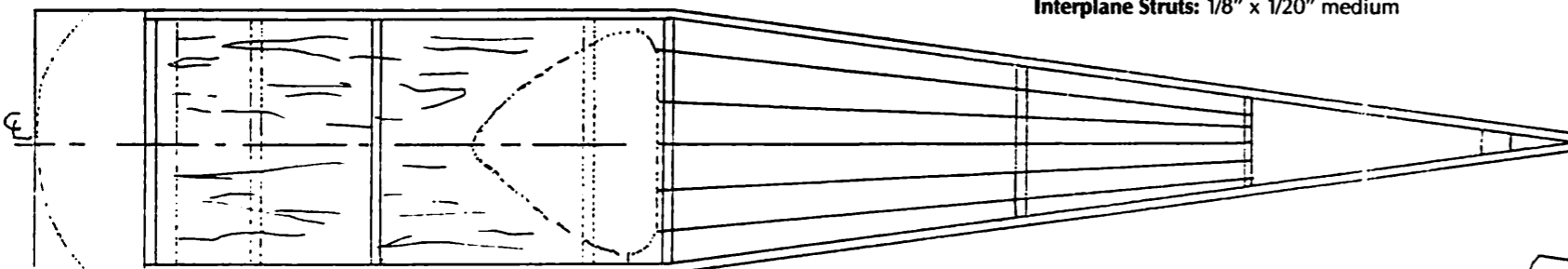

Fuselage:

Longerons, Uprights, Crosspiece: 1/20" x 1/20; firm for longerons, balance light stock
Bulkheads: 1, 2 & 3 from 1/20" light, 4 & 5 from 1/32" light
Stringers: 1/32" x 1/20" light
Cabane: 1/20" x 1/8" firm

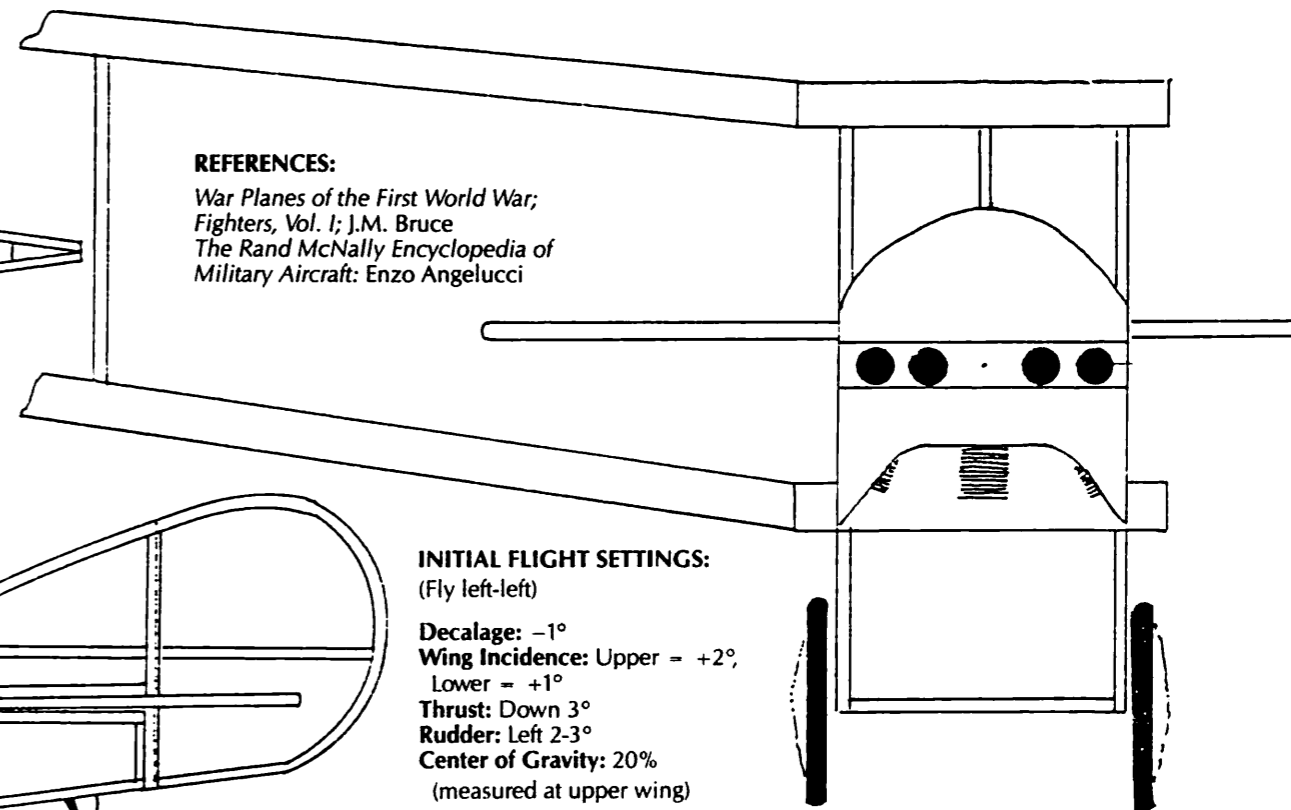
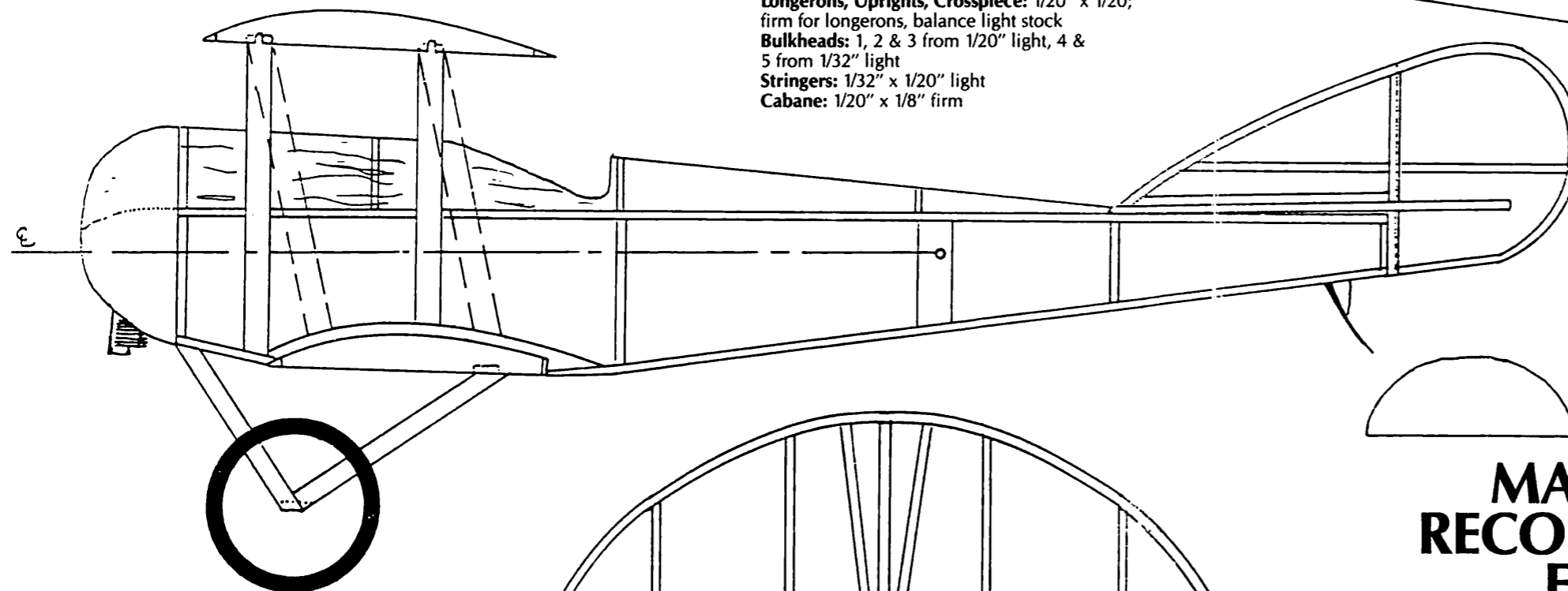

REFERENCES:

War Planes of the First World War; Fighters, Vol. I; J.M. Bruce
The Rand McNally Encyclopedia of Military Aircraft; Enzo Angelucci

INITIAL FLIGHT SETTINGS:

(Fly left-left)
Decalage: -1°
Wing Incidence: Upper = +2°, Lower = +1°
Thrust: Down 3°
Rudder: Left 2-3°
Center of Gravity: 20% (measured at upper wing)



MARTINSYDE S-1: A 1915 RECONNAISSANCE AIRCRAFT FOR PEANUT SCALE

Designed and Drawn By John Berryman

Rudder & Stab:

Outlines: 2 laminations light 1/32" x 1/20"
Structure: 1/20" x 1/20" light

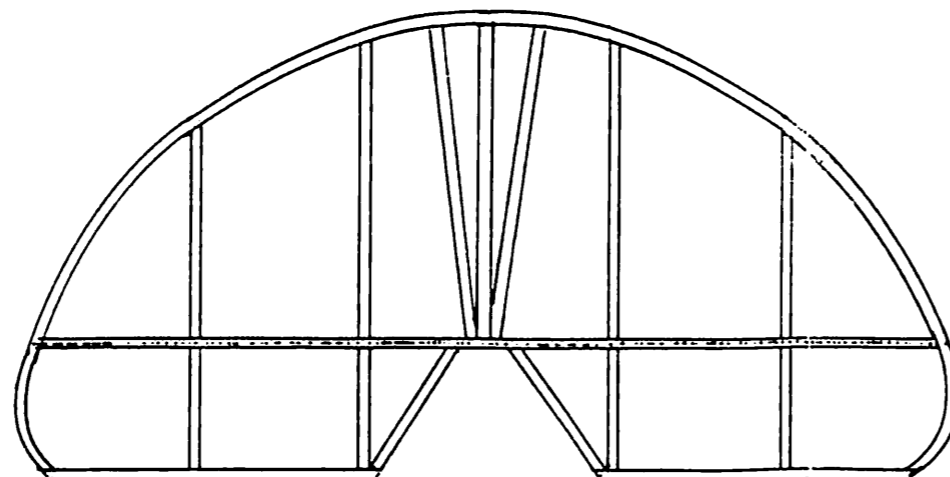

COLOR SCHEME:

Overall: Dr. P.H. Martin's "Yellow Ochre" used to dye tissue ("antique")
Cowl and Nose Block: Silver

Insignia: Red, white and blue Union Jack on rudder
Struts and gear legs: dark brown ("wood")
Numbers: Black
NOTE: Ailerons on both upper and lower wings